



# ALE-2/ALE-3 Basic DeskPhone

## User Manual

8AL91438ENAB ed03

**Legal Notice:**

www.al-enterprise.com The Alcatel-Lucent name and logo are trademarks of Nokia used under license by ALE. To view other trademarks used by affiliated companies of ALE Holding, visit: [www.al-enterprise.com/en/legal/trademarks-copyright](http://www.al-enterprise.com/en/legal/trademarks-copyright). All other trademarks are the property of their respective owners. The information presented is subject to change without notice. Neither ALE Holding nor any of its affiliates assumes any responsibility for inaccuracies contained herein.  
© Copyright 2024 ALE International, ALE USA Inc. All rights reserved in all countries.

## Introduction

Thank you for choosing an Alcatel-Lucent Enterprise phone.

This document describes the services offered by the ALE-2/ALE-3 Basic DeskPhone connected to an ALE SIP server.



ALE-2 Basic DeskPhone



ALE-3 Basic DeskPhone

The phone described in this document is supported on SIP server, and some features described in this document depend on the SIP server to which the phone is connected. If more information about system compatibility or about the level of features for a given SIP server is needed, please contact your system administrator.

The main features of the ALE-2/ALE-3 Basic DeskPhone are listed as follows:

- Multiple accounts
- 2.8-Inch black-and-white screen (ALE-2)
- 2.8-Inch color screen (ALE-3)
- Adjustable screen brightness
- Adjustable phone angle
- RJ9 handset port
- RJ9 headset port
- USB-A port (ALE-3)
- Dual 1000 Mbps Ethernet ports (POE)
- External power supply
- Wall-mounted
- Switching among multiple audio modes
- IP Call
- Web based management
- OpenVPN
- Easy Deployment Server (EDS)
- OXE DM and 8770 DM supported

<b>1</b>	<b>Getting started</b>	<b>7</b>
1.1	Packaging list	7
1.2	Installing your desk phone	7
1.2.1	Connecting your desk phone	7
1.2.2	Installing the foot	8
1.2.3	Installing a wired handset	8
<b>2</b>	<b>Getting to know your desk phone</b>	<b>9</b>
2.1	ALE-2 Basic DeskPhone	9
2.2	ALE-3 Basic DeskPhone	10
2.3	Main screen	11
2.4	Call management interface	12
2.5	Navigation keys	12
2.6	Permanent function keys	13
2.7	Programmable key icons	13
2.8	Telephone status/call icons	14
2.9	Alpha-numeric dialpad	15
2.10	Desk phone connectors	16
<b>3</b>	<b>Using your desk phone</b>	<b>17</b>
3.1	Information about the phone	17
3.1.1	Information about the events	17
3.1.2	Information about the phone status	17
3.2	Multiple SIP accounts	18
3.2.1	Configuring the program keys for an account	18
3.2.2	Defining the default SIP Account	18
3.3	Making a call	19
3.3.1	Opening the dialer	19
3.3.2	Dialing the phone number	19
3.3.3	Calling by name	20
3.3.4	Calling from the call log	20
3.3.5	Calling using your personal directory	21
3.3.6	Calling using Speed Dial key	21
3.3.7	Making a peer to peer SIP call	21
3.4	Receiving a call	22
3.5	Switching between audio modes	22
3.6	Redialing	23
3.6.1	Redial list	23
3.7	Directory management	23
3.7.1	Contacts	23
3.7.2	Contacts management	24
3.7.3	Calling your contact	24
3.7.4	Creating a new contact	25
3.7.5	Creating a new group	25
3.7.6	Modifying a contact	25
3.7.7	Delete a contact	26
3.7.8	Deleting all contacts	26
3.7.9	Deleting a group in the local directory	26
3.7.10	Deleting all groups in the local directory	26
3.8	Managing the call log (history)	27
3.8.1	Calling a contact	28
3.8.2	Displaying missed calls only	28

3.8.3	Deleting the call log of a contact	28
3.8.4	Clearing the call log	28
3.9	Managing speed dial	29
3.9.1	Creating a Speed Dial key	29
3.9.2	Making a call using speed dial	29
3.10	Sending DTMF signals	29
3.11	Muting the microphone	30
3.12	Auto answer	30
3.13	Configuring intercom calls	30
3.14	Changing a PIN code	31
3.15	Locking/Unlocking your desk phone	31
3.15.1	Locking your desk phone	31
3.15.2	Unlocking your desk phone	32
3.15.3	Activating or deactivating the automatic keypad lock	32
3.16	During a conversation	32
3.17	Making a second call during a conversation	33
3.18	Answering a second call during a conversation	33
3.19	Canceling your second call and resuming the first call	34
3.20	Switching between calls	34
3.21	Transferring a call	34
3.21.1	Transferring a call to another contact on hold	34
3.22	Placing a call on hold	34
3.22.1	Transferring your call to another contact	35
3.22.2	Blind transfer	35
3.23	Three-party conference	36
3.23.1	End conf	36
3.23.2	Leaving your two contacts talking together after the conference	36
3.24	Six-party conference	36
3.24.1	End conf	37
3.25	Hiding your phone number	37
3.26	Rejecting anonymous calls	37
3.27	Do not disturb (DND)	38
3.28	Call Forward	38
3.29	Canceling call forwarding	39
3.30	Listening to your voice messages	39
3.31	Defining a hotline number	40
<b>4</b>	<b>Doing more with your desk phone</b>	<b>41</b>
4.1	Configuring your desk phone for remote working	41
4.2	Hot Desking	42
4.2.1	Log on to Hot Desking	42
4.2.2	Log off from Hot Desking	42
<b>5</b>	<b>Customizing your desk phone</b>	<b>43</b>
5.1	Adjusting the audio features	43
5.1.1	Selecting the ringing	43
5.1.2	Adjusting the ringing volume	43
5.1.3	Configuring the ring mode	43
5.1.4	Configuring the beep mode	44
5.1.5	Configuring the seat mode	44
5.2	Selecting a language	44
5.3	Adjusting the brightness of the desk phone	45
5.4	Enabling the Screen Saver and defining the Wait Time	45

5.5	Configuring the wall paper (ALE-3)	45
5.6	Configuring the homepage format	46
5.7	Defining the voicemail number	46
5.8	Programmable keys	46
5.8.1	Creating a programmable key	46
5.8.2	Deleting a programmable key	47
5.8.3	Type of supported programmable keys	47
5.9	Call pick-up	48
5.10	Activating the headset mode	49
5.11	Defining Time and Date format	49
5.12	Energy saving	49
<b>6</b>	<b>Contacting your administrator (technical support)</b>	<b>50</b>
6.1	Technical code / Date code	50
6.2	Viewing the software version/network settings (IP address)	50
6.3	Accessing administrator configuration	51
6.3.1	Default password	51
6.3.2	Advanced Settings	51
6.3.3	Web Based Management (WBM)	51
<b>7</b>	<b>Accessories</b>	<b>53</b>
7.1	Headset	53
7.2	Wall mounting kit	53
7.3	Ethernet cable	53
<b>8</b>	<b>Technical specifications</b>	<b>54</b>
<b>9</b>	<b>Ordering information</b>	<b>55</b>
<b>10</b>	<b>Guarantee and clauses</b>	<b>56</b>
10.1	Safety instructions	56

# 1 Getting started

## 1.1 Packaging list

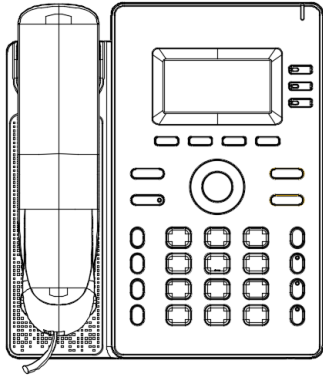

Desk phone



Handset

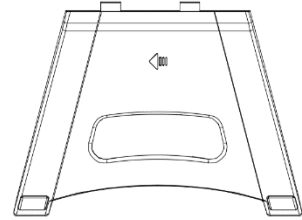

Phone stand



Handset cord

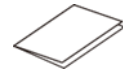

Safety manual and  
quick user guide

## 1.2 Installing your desk phone

### 1.2.1 Connecting your desk phone

Please read the safety instructions beforehand.

Firstly, connect the handset cord to the lower notch (4) if it is not correctly connected (your phone is usually provided with the handset cord connected).

If your desk phone is not correctly configured, you can connect it to the network (1) ((2) is used to connect to your PC). If your desk phone is not powered by PoE (Power over Ethernet), you have to connect the phone to the external power supply which supports DC JACK connector (3). For more information, contact your administrator.

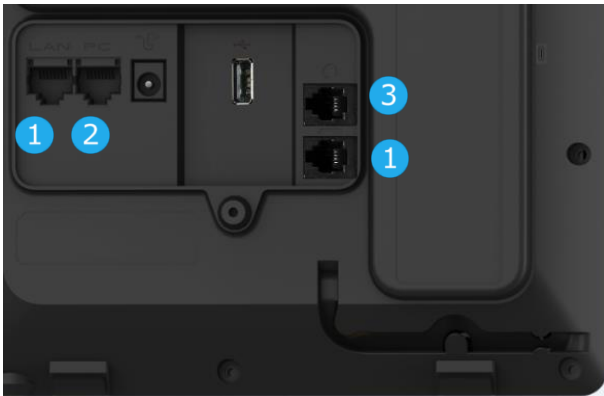

ALE-3 Basic DeskPhone

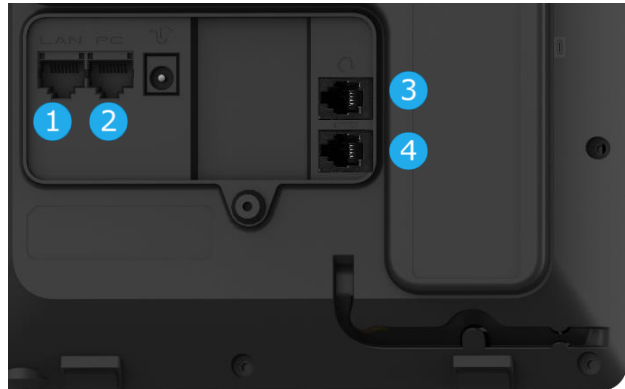

ALE-2 Basic DeskPhone

## 1.2.2 Installing the foot

You can use those three compartments on the back side to fix the phone. Depending on the way you insert the foot into the compartment, your desk phone will have a different angle:

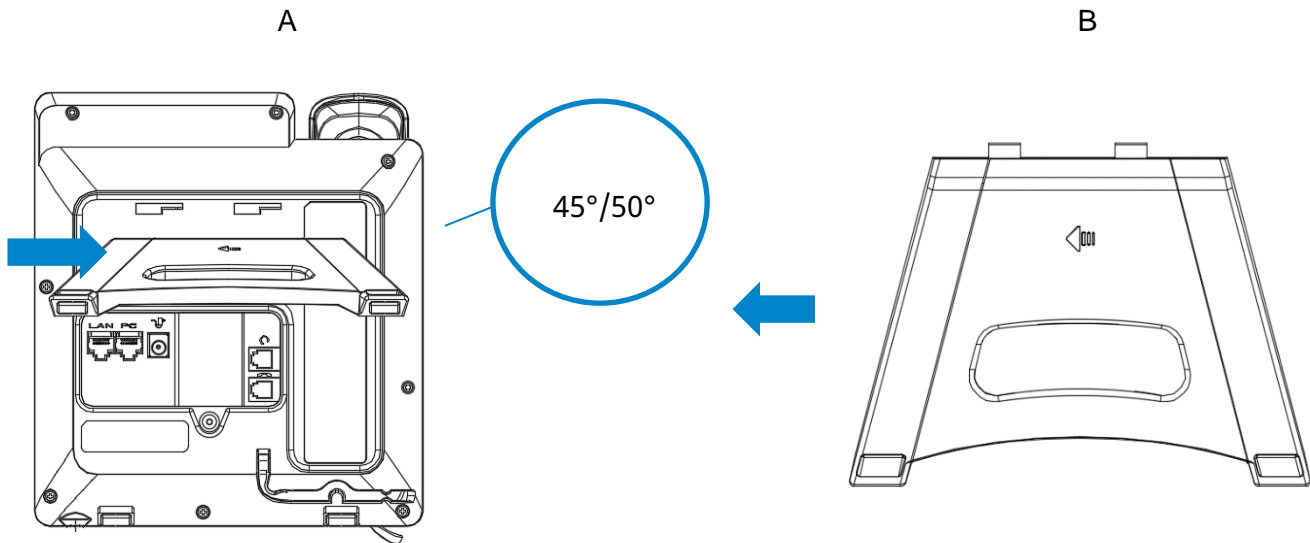

To mount the foot, push it to the right as the arrow indicates in the picture on the left.

To remove the foot, pull it to the left as the arrow indicates until it separates from the phone.

## 1.2.3 Installing a wired handset

By default, your handset cord is correctly connected to the phone. If you have to replace it:

- Please refer to the previous section, then plug-in the wired handset to the appropriate connector.
- Make sure you position and fix the cord correctly in the compartment intended for that purpose.

# 2 Getting to know your desk phone

## 2.1 ALE-2 Basic DeskPhone

The ALE-2 Basic DeskPhone is part of the new Alcatel-Lucent Enterprise DeskPhones, and is equipped with a backlight black-and-white display associated with 3 dedicated function keys, and an intuitive navigation key. The desk phone delivers an excellent user experience and optimum calling effect, and is compatible with remote working VPN. In this way, it is perfect for use at your office or at home (remote working). The ALE-2 Basic DeskPhone supports dual 1000 Mbps Ethernet ports.



1	2.8-inch black-and-white screen	6	Navigation key
2	8 virtual programmable keys (navigating through 4 pages) allow you to configure various features including SIP accounts and speed dial. You can navigate through pages on the screen with the navigation key to use different keys.	7	HD loudspeakers
3	Soft keys: provide menu options and corresponding features. Soft keys can be configured for different options by the administrator. <ul style="list-style-type: none"> <li>In Idle state: you can press soft keys to enter different levels of menus to operate and manage the phone.</li> <li>In the conversation mode: soft keys perform different actions depending on the application scenarios.</li> </ul>	8	HD wide-band wired handset
4	Function keys: provide quick access to the phone's features.	9	2-degree foot (45°, 50°)
5	LED indicator light		

## 2.2 ALE-3 Basic DeskPhone

The ALE-3 Basic DeskPhone is part of the new Alcatel-Lucent Enterprise DeskPhones, and is equipped with a color display associated with 4 dedicated function keys, and an intuitive navigation key. The desk phone delivers an excellent user experience and optimum calling effect, and is compatible with remote working VPN. In this way, it is perfect for use at your office or at home (remote working). The ALE-3 Basic DeskPhone supports dual 1000 Mbps Ethernet ports.



1	2.8-inch color screen	6	Navigation key
2	12 virtual programmable keys (navigating through 4 pages) allow you to configure various features including SIP accounts and speed dial. You can navigate through pages on the screen with the navigation key to use different keys.	7	HD loudspeakers
3	Soft keys: provide menu options and corresponding features. Soft keys can be configured for different options by the administrator. <ul style="list-style-type: none"> <li>In Idle state: you can press soft keys to enter different levels of menus to operate and manage the phone.</li> <li>In the conversation mode: soft keys perform different actions depending on the application scenarios.</li> </ul>	8	HD wide-band wired handset
4	Function keys: provide quick access to the phone's features.	9	2-degree foot (45°, 50°)
5	LED indicator light		

## 2.3 Main screen

The main screen, composed of 4 pages, displays all the information about program keys, such as the registered SIP account and speed dial.

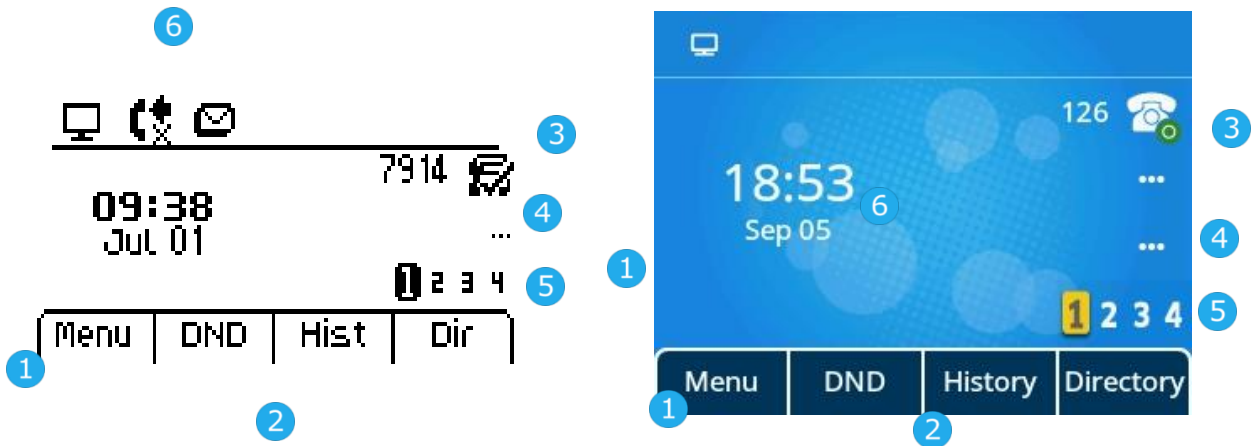

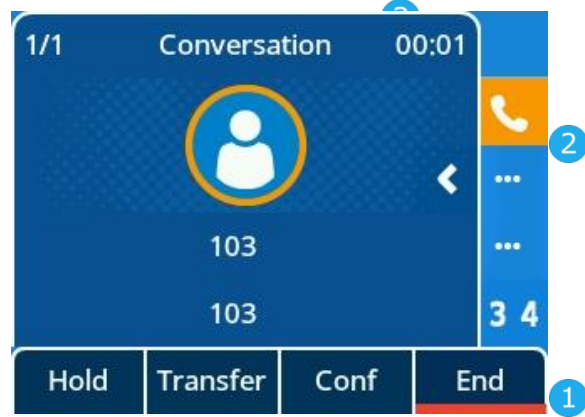
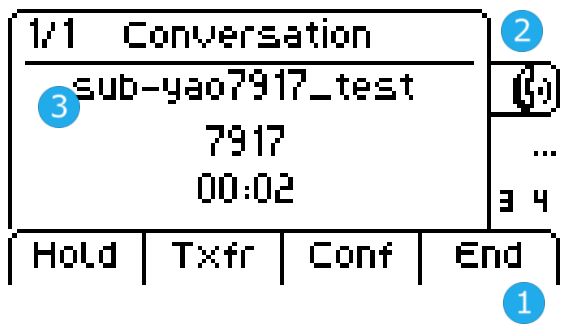

1	Press the Menu soft key to display submenus for various features and configuring or managing the phone. Use up-down navigation keys to navigate through the menu items. Press OK to perform the selected menu features.
2	Access features of the phone via 3 dynamic keys that are configurable by your administrator depending on your needs.
3	Line keys (hard keys) are associated with SIP accounts. Press the line key associated with a SIP account to make a call with this account or to answer an incoming call to this account.
4	Programmable keys Press the program key to perform a configured action, such as making an immediate call. Long press the programmable key to enter the interface for program key configuration.
5	Virtual page navigation key Use the left-right navigation keys or the program key next to the '1234' icon to navigate through virtual pages. The number of the current page is highlighted.
6	Displays date, time and some status icons of the phone.

## 2.4 Call management interface













1	Features on the soft key labels depend on the call status. Press the relevant key to perform a specific action. For example, you can pause transfer the current call.
2	Displays SIP account in conversation.
3	Displays the incoming call and the corresponding conversation status, such as number and duration.

## 2.5 Navigation keys



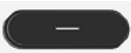











	<p><b>OK key:</b> Press OK key to validate the status of an option.</p> <p><b>Left-Right navigation keys:</b> Use the left-right navigation keys to move the cursor, move the option or move from one page to another when typing in a text field.</p> <p><b>Up-Down navigation keys:</b> Use the up-down navigation keys to select an item on a list. When the information extends more than one page, you can use the Down navigation key to display the next page and the Up navigation key to display the previous page. Use up-down navigation keys on a menu to browse the item or an option on the menu.</p>
	<p><b>Back/Exit key:</b> Use C key to go back to the previous menu.</p>
<i>Bkspc</i>	Delete the last entered number or character.
<i>More</i>	More options.





















## 2.6 Permanent function keys

	<ul style="list-style-type: none"> <li>• Answer an incoming call or make a call.</li> <li>• Short press to enter the list of last numbers dialed.</li> </ul>
	<ul style="list-style-type: none"> <li>• Place a call on hold.</li> <li>• Recover the call on hold.</li> </ul>
	<ul style="list-style-type: none"> <li>• Transfer a call.</li> </ul>
	<ul style="list-style-type: none"> <li>• Add participants to a conference call.</li> </ul>
	<ul style="list-style-type: none"> <li>• Reject an incoming call.</li> <li>• Hang up.</li> <li>• Return to the main screen.</li> </ul>
	<ul style="list-style-type: none"> <li>• Press this key during a call to stop your contact from hearing you. When activated, the mute key is lit red.</li> </ul>
	<ul style="list-style-type: none"> <li>• Voice mail</li> </ul> <p>The message key flashes when you have missed an incoming call or received a new voice mail. The key stays on if there are old messages in the voice mailbox.</p>
	<ul style="list-style-type: none"> <li>• Press this key to open dialer in handsfree mode.</li> <li>• Press this key to answer an incoming call in handsfree mode.</li> <li>• When a call is in progress, press this key to switch from handsfree mode to headset or handset mode.</li> </ul>
	<ul style="list-style-type: none"> <li>• Decrease the ringer volume in idle state or when you receive an incoming call.</li> <li>• Decrease the volume of the handset, loudspeaker or headset during a telephone call.</li> </ul>
	<ul style="list-style-type: none"> <li>• Increase the ringer volume in idle state or when you receive an incoming call.</li> <li>• Increase the volume of the handset, loudspeaker or headset during a telephone call.</li> </ul>

## 2.7 Programmable key icons















This table lists icons displayed on the main screen when you program a key. To program a key, see Section 5.7 Programmable keys.









		<ul style="list-style-type: none"> <li>• SIP Accounts</li> </ul>
		<ul style="list-style-type: none"> <li>• Speed Dial</li> </ul>
		<ul style="list-style-type: none"> <li>• Hold</li> </ul>
		<ul style="list-style-type: none"> <li>• Call Transfer</li> </ul>
		<ul style="list-style-type: none"> <li>• Conference</li> </ul>
		<ul style="list-style-type: none"> <li>• Redial the last number</li> </ul>
		<ul style="list-style-type: none"> <li>• Do not disturb (DND)</li> </ul>

		<ul style="list-style-type: none"> <li>• Directory</li> </ul>
		<ul style="list-style-type: none"> <li>• Forward</li> </ul>
		<ul style="list-style-type: none"> <li>• Voice Mail</li> </ul>
		<ul style="list-style-type: none"> <li>• Hot Desking</li> </ul>
		<ul style="list-style-type: none"> <li>• Prefix</li> </ul>
		<ul style="list-style-type: none"> <li>• DTMF Tone</li> </ul>
		<ul style="list-style-type: none"> <li>• Direct Pickup</li> </ul>
		<ul style="list-style-type: none"> <li>• Group Pickup</li> </ul>
		<ul style="list-style-type: none"> <li>• Headset</li> </ul>
		<ul style="list-style-type: none"> <li>• Group Listen</li> </ul>
		<ul style="list-style-type: none"> <li>• Intercom</li> </ul>
		<ul style="list-style-type: none"> <li>• XML Browser</li> </ul>
		<ul style="list-style-type: none"> <li>• Phone Lock</li> </ul>

## 2.8 Telephone status/call icons

Icons provide information of a certain status or the status of a specific call.

Status icons	<p>Depending on the size of the display, all status icons may not be displayed simultaneously. The icons displayed depend on their priority. The following icons are listed according to their priority, from the highest to the lowest.</p> <p>Status icons are displayed on the status bar at the top of the screen.</p>	
		Silent mode
		Telephone locked
		Headset connected
		Handsfree connected
		Auto answer mode
		Do not disturb (DND)
		Upgrade in progress

Call icons	Call icons are associated with SIP accounts.	
		SIP Accounts (idle state)
		Incoming Call
		Call in Progress
		Call On Hold





## 2.9 Alpha-numeric dialpad

The phone is equipped with an alphanumeric dialpad. You can switch between numeric dialpad to dial number, and alphabetic dialpad to enter text by pressing the corresponding programmed key.

- Switch between the alphabetic and numeric modes:

<i>abc/ABC/Abc</i>	When in a text box, you can switch to the alphabetic dialpad by pressing “123”.
<i>123</i>	When the alphabetic mode is activated, you can switch to the numeric mode by pressing “abc/ABC/Abc”.

- Enter alphabetic characters  
The numeric dialpad has letters that can be displayed by successively pressing. The number is the last character in the series. Some special characters can be displayed by successively pressing the key:

	%      \$ / ~      &      ( )      [ ]      = *
	@      #
	space      - _ 1
	+      . , ; : / \ ? ! 0

- Use navigation keys

	You can use navigation keys to move the cursor into the text.
---	---

- Delete the last entered character

<i>Bkspc</i>	You can use the key to delete the last entered character. The alphabetic mode remains activated.
--------------	--

## 2.10 Desk phone connectors

The phone supports multiple connectors, which you can use to extend the features of the phone.

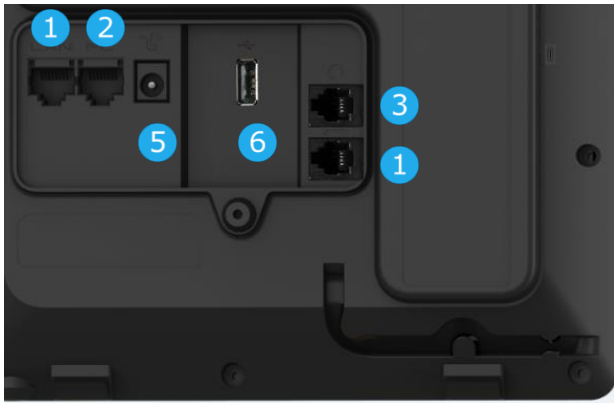

ALE-3 Basic DeskPhone

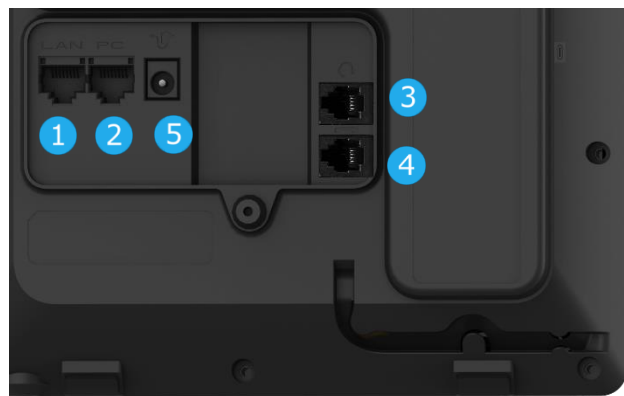

ALE-2 Basic DeskPhone

1	1000 Mbps Ethernet port to the local area network (RJ45), also supporting Power over Ethernet (PoE)
2	1000 Mbps Ethernet port to a PC (RJ45)
3	Wired headset connector (RJ9)
1	Wired handset connector (RJ9)
5	External power supply
6	USB port (ALE-3)

# 3 Using your desk phone

## 3.1 Information about the phone

The main screen can display all SIP accounts used on the phone and programmable keys.

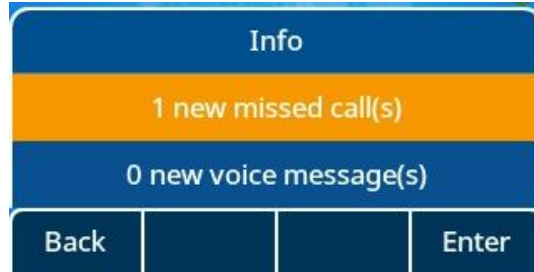

Information about new events such as missed calls and new voice mail(s) are displayed in a pop-up on the main screen. The message key flashes red when you have received a new voice mail or missed an incoming call.

### 3.1.1 Information about the events

	Press the message key to display a new event pop-up.
	Enter with up-down navigation keys to view the event details.
or <i>Enter</i>	Enter the interface of a new event.



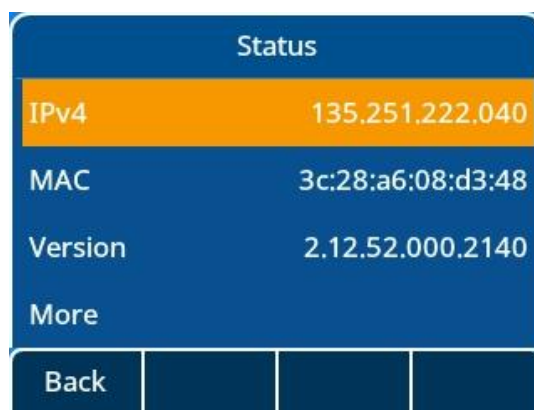
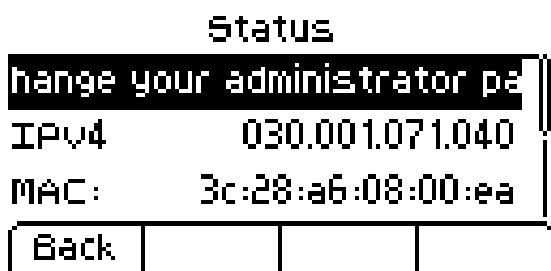

### 3.1.2 Information about the phone status

In idle screen, you can press the OK key to get the phone's basic information, including the phone's IP address, MAC address, and software version, etc. You can also use up-down navigation keys to select More for information about the phone's network and account.



## 3.2 Multiple SIP accounts



The ALE-2 Basic DeskPhone supports 3 SIP accounts, and the ALE-3 Basic DeskPhone supports 4 SIP accounts. A default account will be used for calls unless you select the relevant account prior the call. It is recommended to program a key for each SIP account and put the key on the homepage. Then the status of the account will be displayed on the homepage. The key of the SIP account used to receive calls will flash. You can quickly answer the call to a certain account by pressing the program key. The descriptions of different account icons are as follows:

	If you configure an account key on the homepage, press it to select the corresponding account for making a call.
	Call forward is activated for this account.
	DND is activated for this account.
	The registration for this account failed.

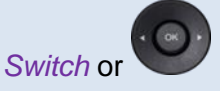
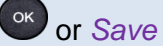
### 3.2.1 Configuring the program keys for an account

	Long press on a program key.
	Select the type of the program key: Account Select the relevant account. Add a label.
	Save the configuration for this program key.

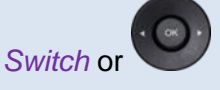
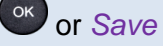



### 3.2.2 Defining the default SIP Account

	The phone is in idle state.
<i>Menu</i>	Press the Menu key to enter the Main Menu.
<i>Features</i>	Use up-down navigation keys and OK key to select: <i>Features</i> .
<i>Default Account</i>	Use up-down navigation keys and OK key to select Default Account.
	Save an account as the default account.
	Validate your choice
	Complete the settings

### 3.3 Making a call





This section describes how to make a call. We provide different methods to open the dialer before calling your contact.

#### 3.3.1 Opening the dialer

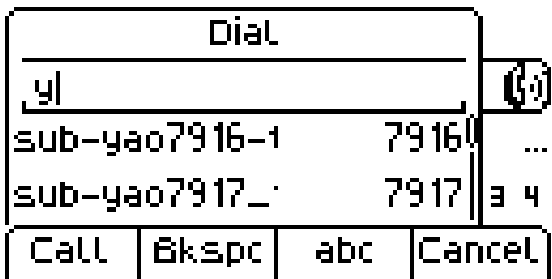
Use one of the following methods:	
	Enter the number directly on the dialpad.
	Offhook the handset.
	Press the Dial key.
	Press the Handsfree key.
	If a program key for SIP account is set on the homepage, press the SIP account key to access the dialer.

#### 3.3.2 Dialing the phone number



	Open the dialer
Use one of the following methods:	
	Enter the number
	Select the corresponding contact from the dial out list.
Use one of the following methods:	
	Press the Dial key. Make the call with the active device: handset if offhooked, headset if connected, otherwise in handsfree mode.
	Press the OK key to make a call.
<i>Call</i>	Press the Call key to make a call.
<i># or *</i>	If defined in the phone settings, you can use these keys to initiate the call.

Depending on the system, after dialing the number, the call can be started automatically after a delay without action.





When you are in handsfree mode, you can take the call at any time on the handset by offhooking it. Or press the Headset key to switch the audio from handsfree to headset or from headset to handsfree.

To make an external call, dial the outside line access code before dialing your contact number. The call will start after a timeout of approx. 10 seconds if there is no action taken after dialing. If you are using multiple SIP accounts on your phone, you can choose an account to make the call.

### 3.3.3 Calling by name



You can call a contact by his/her name using the search feature in the company directory. This feature depends on the system configuration. If necessary, contact your administrator.

Use the alpha-numeric dialpad to switch between the numeric and alphabetic dialpad.

	Open the dialer.
<i>abc</i>	Switch to the alphabetical dialpad.
	Enter the first letter of your contact's name. The corresponding contacts will appear in a list. Entering more characters will narrow the search until the matched name is displayed.
	Use up-down navigation keys to select the contact you want to call.
Use one of the following:	
	Press the Dial key. Make the call with the active device: handset if unhooked, headset if connected, otherwise in handsfree mode.
	Press the OK key to make a call.
<i>Call</i>	Press the Call soft key to start the call.
# or *	If defined in the phone settings, you can use these keys to initiate the call.

### 3.3.4 Calling from the call log





You can call back a contact from the call log.

From the homepage or the dialer:	
<i>History</i>	Select the soft key to open call logs.
	Use up-down navigation keys to select the contact you want to call.
Use one of the following:	
	Press the Dial key. Make the call with the active device: handset if unhooked, headset if connected, otherwise in handsfree mode.
	Press the OK key to make a call.
<i>Call</i>	Press the Call soft key to start the call.

If you are using multiple SIP accounts on your phone, the call back is made with the SIP account displayed in the call log.

### 3.3.5 Calling using your personal directory



You can unhook the handset or the headset to make a call with the handset or the headset, otherwise you make a call in handsfree mode.

From the homepage or the dialer:	
<i>Directory</i>	Select the soft key to open your local directory from the homepage or the dialer.
	Select a directory.
	Select the contact to call.
Use one of the following:	
	Press the Dial key. Make the call with the active device: handset if unhooked, headset if connected, otherwise in handsfree mode.
	Press the OK key to make a call.
<i>Call</i>	Press the Call soft key to start the call.

If you are using multiple SIP accounts on your phone, you can choose which account to use to make the call.

### 3.3.6 Calling using Speed Dial key

You can pre-define the speed dial by long pressing the program key to the right of the LCD, entering the "Program Keys" setting page, choosing "Speed Dial" as Key Type, and inputting the number to be called and account.

	 Long press to choose Speed Dial.
---	--

If you are using multiple SIP accounts on your phone, you must choose which account to use to make the call.

### 3.3.7 Making a peer to peer SIP call

Your phone is compatible with the peer to peer IP call. It is able to call phones connected to the same local network. You can call your contact by entering the IP address of your contact's deskphone.





	Open the dialer. Enter the IP address of the peer end, such as 10*0*0*1, then dial out.
---	--

The format of the entered IP address must be x\*x\*x\*x where x is a decimal value between 0 and 255.

This feature is useful when you have no connection to a communication server (no registration, network problems, etc.). Not all the features are available. Should this occur and the phone's status should be displayed on the screen. This feature can be deactivated by your administrator.

### 3.4 Receiving a call

When receiving a call, you can:

	Unhook the handset to take the call.
	Press the Headset key to activate the headset and take the call.
	Press the Loudspeaker/Handsfree key to take the call in handsfree mode.
	Press the blinking line key to take the call.
Take or 	Take the call with the headset if connected, or in handsfree mode.
 or Reject	Transfer the call to your voicemail.
Mute	Mute the ringer (the call is still incoming but the phone no longer rings).
Transfer	Transfer the call to another number.

### 3.5 Switching between audio modes

During the conversation, you can switch between different audio modes (handset, handsfree or headset, if connected) by pressing the Loudspeaker/Handsfree key or Headset icon. This feature depends on connected devices.

- When you are in conversation using the handset, you can switch between handset and handsfree by pressing the Handsfree key.



- When you are in conversation using the headset, you can switch between headset, handset and hand free by pressing the Handsfree or Headset key or unhooking the handset.

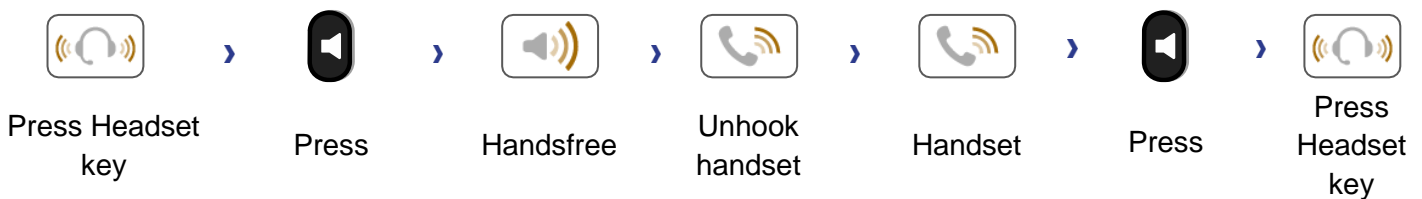

- You can pre-program the group listening key and press the program key during a call to activate the feature.



For each audio mode, during the conversation, you can adjust the volume by pressing the volume keys. The number of levels depends on the audio mode (8 for handset and headset, 10 for handsfree).

## 3.6 Redialing

### 3.6.1 Redial list







Short press to enter the redial list. The last dialed number is highlighted.  
You can also press the Call key.  
Press the OK key to display details.

## 3.7 Directory management

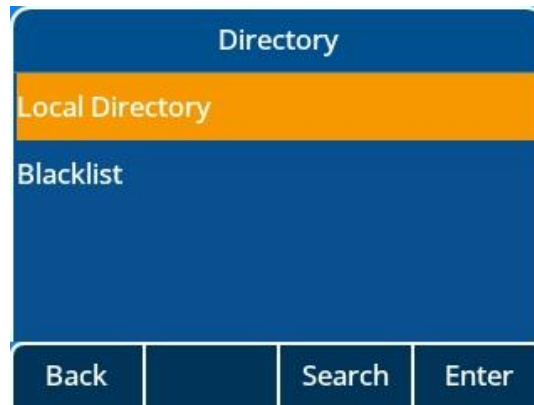
### 3.7.1 Contacts

A contact can be opened from your local directory.



<i>Directory</i>	Select the soft key to open your directory.
	Open a directory.
	Select a contact.
<i>More → Detail</i>	Modify a contact.
	Use up-down navigation keys to select items to be modified.

The contact card displays information about the contact.

- Avatar: Select a predefined image.
- Last name
- First name
- Office number
- Mobile
- Other
- Account: If you are using multiple SIP accounts, define an account to use to call the contact.
- Group: Define the group to which this contact belongs.

### 3.7.2 Contacts management

Your desk phone allows you to manage contacts in your local directory.

How to manage contacts in the directory:

Use one of the following:

<i>Directory</i>	Select the directory on the soft key.
<i>Menu → Directory</i>	Use the menu to access your directory.

Categories of directory:

<i>Directory</i>	Use the menu or soft key to access your directory.
<i>Local Directory</i>	Your local directory stores all saved contacts and groups.
<i>External Directory</i>	ALE-2/ALE-3 supports external LDAP(S).



Operations on contacts in the directory:

<i>Search</i>	Search a contact.
<i>Add</i>	Create a new contact.
<i>Bkspc</i>	Delete a contact.
<i>More</i>	Display more.
<i>Call</i>	Call the selected contact.
<i>Detail</i>	Display information about a contact.
<i>Delete all</i>	Delete all contacts or groups.
<i>AddGrp</i>	Add a new group.
<i>Enter</i>	Confirm the selected items.
<i>Back</i>	Return to the previous menu or main page.



### 3.7.3 Calling your contact

<i>Directory</i>	Select the soft key to open your directory.
------------------	---

Use one of the following methods:

<i>Search</i>	Search for contacts in all directories and groups.
	Select the searched contacts.
	Select the number you want to call.
 or <i>Call</i>	Start the call.

### 3.7.4 Creating a new contact

<i>Directory</i>	Select the soft key to open your directory.
<i>Local Directory</i>	Open the local directory.
<i>Add</i>	Press the soft key to create a new contact.
<i>Switch</i> or 	<ul style="list-style-type: none"> <li>Avatar: Select a predefined image.</li> <li>Account: If you are using multiple SIP accounts, define an account to use to call the contact.</li> <li>Group: Define the group to which this contact belongs.</li> </ul>
<Abc>	<ul style="list-style-type: none"> <li>Last name</li> <li>First name</li> </ul>
<123>	<ul style="list-style-type: none"> <li>Office number</li> <li>Mobile</li> <li>Other</li> </ul>
 or <i>Save</i>	The new contact is added to the local directory.

Other method:



- Add a contact from the call log.

For external numbers, we recommend you use a canonical address format comprising '+', followed by the country code (e.g. '33'), and then the number without the first digit (e.g.+33 1 55 66 70 00). To get the '+' sign, long press on the '0' key. This example is for calling a number in France from another country.

### 3.7.5 Creating a new group

<i>Directory</i>	Select the soft key to open your directory.
<i>Local Directory</i>	Open the local directory.
<i>AddGrp</i>	Select to add a group.
<Abc><123>	Enter the name of the group.
 or <i>Save</i>	The new group is added to the directory.

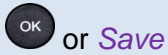

### 3.7.6 Modifying a contact

<i>Directory</i>	Select the soft key to open your directory.
<i>Local Directory</i>	Open the local directory.
	Select the contact to modify.
<i>More</i>	Access more features.
<i>Detail</i>	Access the contact's information.
	Fill in the contact information. Use up-down navigation keys to edit a field.





Save the contact in the local directory.



### 3.7.7 Delete a contact

<i>Directory</i>	Select the soft key to open your directory.
	Select the soft key to access your directory.
	Use up-down navigation keys to select the contact to be deleted.
<i>Bkspc</i>	Press the soft key.
	Confirm the deletion.



### 3.7.8 Deleting all contacts

<i>Directory</i>	Select the soft key to open your directory.
<i>Local Directory</i>	Open the local directory.
	Use up-down navigation keys to select the contact to be deleted.
<i>More</i>	Press the soft key.
<i>Delete all</i>	Delete all the contacts.
	Confirm the deletion.

### 3.7.9 Deleting a group in the local directory

<i>Directory</i>	Select the soft key to open your directory.
<i>Local Directory</i>	Open the local directory.
<i>Group</i>	Access a group.
	Select the group to be deleted.
<i>Bkspc</i>	Press to delete a group.
	Confirm the deletion.

### 3.7.10 Deleting all groups in the local directory

<i>Directory</i>	Select the soft key to open your directory.
<i>Group</i>	Access a group.
	Select the group to be deleted.
<i>Delete all</i>	Press to delete a group.
	Confirm the deletion.

### 3.8 Managing the call log (history)

The call log can be queried and managed when the phone is in the idle state.



The call log is accessible from the dynamic program key on the phone homepage or by the menu.

Use one of the following methods:

<i>History</i>	If configured, use the History dynamic program key to access to the call log directory.
<i>Menu → History</i>	Use the Menu key to access the call log.

In this user manual, we use the dynamic program key to access the call log.



All call logs are displayed with an icon showing the type of call.

	Answered incoming calls.
	Missed calls.
	Unanswered incoming call that has been acknowledged.
	Answered outgoing calls.
	Unanswered outgoing calls.

Actions available from the call log:

<i>Bkspc</i>	Delete the selected entry. Note that no confirmation is requested.
<i>Call</i>	Call the selected entry.
<i>More</i>	Access more features.
or <i>Detail</i>	View details about the selected entry: name, number, time, relevant SIP account, and duration.
<i>Delete all</i>	Delete the entire log associated with the selected contact. Note that no confirmation is requested.
<i>Missed</i>	Display missed calls only.
<i>AddClist</i>	Add the selected contact in your local directory. If the contact already exists, the screen for editing the contact is displayed.
<i>Back</i>	Go back to the Homepage.

### 3.8.1 Calling a contact

<i>History</i>	Select the soft key to open call logs from the homepage or the dialer.
	Select the contact to call.
Use one of the following methods:	
	Press the Call key to make a call with the active device: handset if unhooked, headset if connected, otherwise in handsfree mode.
	Press the OK key to make a call with the active device: handset if unhooked, headset if connected, otherwise in handsfree mode.
<i>Call</i>	Press the Call key to make a call with the active device: handset if unhooked, headset if connected, otherwise in handsfree mode.

### 3.8.2 Displaying missed calls only

<i>History</i>	Select the soft key to open call logs from the homepage or the dialer.
<i>Missed</i>	Press this key to display missed calls only.

### 3.8.3 Deleting the call log of a contact

<i>History</i>	Select the soft key to open call logs from the homepage or the dialer.
	Select the contact log to delete.
<i>Bkspc</i>	Delete the selected call log. Note that no confirmation is requested.

### 3.8.4 Clearing the call log

<i>History</i>	Select the soft key to open call logs from the homepage or the dialer.
<i>More</i>	Access more features.
<i>Delete all</i>	Delete all call logs.
 or <i>OK</i>	Confirm the deletion.



If you are using multiple SIP accounts on your phone, the concerned SIP account is displayed in entry details of the call log ( or *Detail*).

## 3.9 Managing speed dial



Speed dial allows you to call a number rapidly. You can create Speed Dial keys by programming keys from the homepage.

### 3.9.1 Creating a Speed Dial key

Use one of the following methods:

	Long press on a free programmable key.
<i>Menu</i> → <i>Features</i> → <i>Program Keys</i>	Use up-down and "OK" navigation keys to select: <i>Program Keys</i> .
Creating a Speed Dial key	
<i>Switch</i> or 	Define the type of programmable key: <i>Speed Dial</i> .
<i>Account</i>	Associate a SIP account for making a call.
<123><Abc>	Enter the number and its label.
 or <i>Save</i>	Save the Speed Dial key.

### 3.9.2 Making a call using speed dial

	 Select the Speed Dial key for making a call.
---	--



## 3.10 Sending DTMF signals

During a conversation, you may have to send DTMF signals, for example, with a voice server, an automated attendant or a remotely consulted answering machine.

	Enter DTMF code.
---	------------------





- To activate or deactivate DTMF mode

The phone is in idle state:

<i>Menu</i>	Press the Menu soft key to access the Main Menu.
<i>Basic Setting</i>	Use up-down and "OK" navigation keys to select: <i>Basic Setting</i> .
<i>Sound</i>	Use up-down and "OK" navigation keys to select: <i>Sound</i> .
<i>DTMF Tone</i>	Use up-down and "OK" navigation keys to select: <i>DTMF Tone</i> .
<i>Switch</i> or 	To activate or deactivate DTMF mode
 or <i>Save</i>	Validate your choice
	End the settings.

### 3.11 Muting the microphone





When you mute the microphone, you can hear your contact but he/she cannot hear you.

During a conversation:	
	Disable the microphone. >>  The key lights up.
	Resume the conversation. >>  The key is no longer lit.

### 3.12 Auto answer



In the auto answer mode, calls are automatically answered.

To enable the auto answer:

The phone is in idle state:	
<i>Menu</i>	Press the Menu soft key to access the Main Menu.
<i>Features</i>	Use up-down and "OK" navigation keys to select: <i>Features</i> .
<i>Auto answer</i>	Use up-down and "OK" navigation keys to select: <i>Auto answer</i> .
	Select the SIP account. All incoming calls to this SIP account will be automatically answered.
<i>Switch</i> or 	Enable the auto answer.
 or <i>Save</i>	Save the setting.
	This icon is displayed in the status bar.

### 3.13 Configuring intercom calls





When you receive an intercom call, the desk phone automatically answers the call if you have enabled this feature. You can manage actions to be taken by your desk phone when you receive an intercom call.

The phone is in idle state:	
<i>Menu</i>	Press the Menu soft key to access the Main Menu.
<i>Features</i>	Use up-down and "OK" navigation keys to select: <i>Features</i> .
<i>Intercom</i>	Use up-down and "OK" navigation keys to select: <i>Intercom</i> .
	Select the SIP account. All incoming calls to this SIP account will be automatically answered.
<i>Switch</i> or 	<ul style="list-style-type: none"> <li>• <i>Allow</i>: Enable/Disable intercom call.</li> <li>• <i>Mute</i>: Enable/Disable mute.</li> <li>• <i>Tone</i>: Enable/Disable tone.</li> <li>• <i>Barge</i>: Enable/disable barge.</li> </ul>
 or <i>Save</i>	Save the setting.

### 3.14 Changing a PIN code



The PIN code is required to unlock the phone.

The default PIN code is 0000.

The phone is in idle state:	
<i>Menu</i>	Press the Menu soft key to access the Main Menu.
<i>Basic Setting</i>	Use up-down and "OK" navigation keys to select: <i>Basic Setting</i> .
<i>Changing a PIN code</i>	Use up-down and "OK" navigation keys to select: <i>Changing a PIN code</i> .
	Enter the current PIN code.
	Enter the new PIN code.
	Confirm the new PIN code.
 or <i>Save</i>	Save the setting.
	End the settings.

### 3.15 Locking/Unlocking your desk phone



To enable the phone lock:

The phone is in idle state:	
<i>Menu</i>	Press the Menu soft key to access the Main Menu.
<i>Basic Setting</i>	Use up-down and "OK" navigation keys to select: <i>Basic Setting</i> .
<i>Phone Lock</i>	Use up-down and "OK" navigation keys to select: <i>Phone Lock</i> .
<i>Switch</i> or 	Enable the option: <i>Lock Enable</i>
	End the settings.

To lock/unlock your desk phone, you can also create a programmable key: *Phone Lock*.

- *Label*: Enter the label of the key displayed on the homepage.

#### 3.15.1 Locking your desk phone

	Select the lock/unlock programmable key.
<i>OK</i> or 	Validate your choice Your phone is locked.





You can only call emergency numbers once the phone is locked (up to 3 numbers, configured by the administrator).

### 3.15.2 Unlocking your desk phone

	Unlock your desk phone. A PIN code is required to unlock the desk phone (the default PIN code is 0000).
---	---

### 3.15.3 Activating or deactivating the automatic keypad lock

The phone is in idle state:

<i>Menu</i>	Press the Menu soft key to access the Main Menu.
<i>Basic Setting</i>	Use up-down and "OK" navigation keys to select: <i>Basic Setting</i> .
<i>Phone Lock</i>	Use up-down and "OK" navigation keys to select: <i>Phone Lock</i> .
<i>Switch</i> or 	Enable the option: <i>Auto Lock Enable</i> .
	Enter the timeout without activity before the keylock (seconds).
 or <i>Save</i>	Validate your choice.
	End the settings.



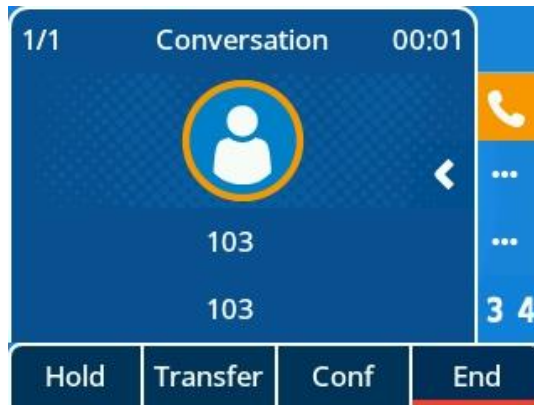
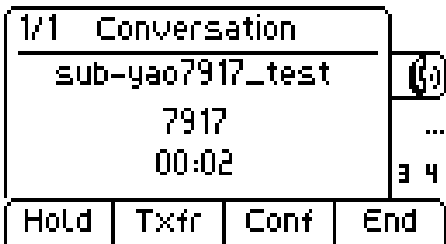

### 3.16 During a conversation







Actions available during a conversation:

<i>End</i>	End the call.
<i>Hold</i>	Place the call on hold.
<i>Transfer</i>	Transfer the call.
<i>Resume</i>	Resume a call (on hold, muted).
<i>New</i>	Make a second call when the first call is on hold.
<i>Swap</i>	Switch between calls.
<i>Conf</i>	Establish a conference call.
<i>End conf</i>	End the conference with all participants.

### 3.17 Making a second call during a conversation

During a conversation:	
<i>Hold</i>	Your first call is placed on hold.
<i>New</i>	The dialer and call log are displayed.
Use one of the following methods:	
	Enter the number
	Select a contact in the call log.
<i>Directory</i> →  or <i>Call</i>	Select a contact from the local directory.
<Abc> →  or <i>Call</i>	Call your contact using the Dial By Name feature.
	Select the Redial feature.

### 3.18 Answering a second call during a conversation

	During a conversation, another person is trying to call you. You are alerted with 3 beeps. The information about the second call is displayed on the screen. The key of the SIP account is blinking blue.
Use one of the following methods:	
	Press the blinking line key associated with the SIP account receiving the call.
<i>Take</i> or 	Take the call with the headset if connected, or in handsfree mode.
 or <i>Reject call</i>	Deflect the call to your voicemail.
<i>Mute key</i>	Mute the ringing (the call is still incoming but the phone no longer rings).
<i>Forward</i>	<p>Transfer the call to another contact.</p> <p>Use one of the following:</p> <ul style="list-style-type: none"> <li>• Use the up-down navigator (if necessary) to find the contact to call.</li> <li>• Enter the number or name of the contact to whom the call will be transferred.</li> </ul> <p> Transfer the call to the selected contact.</p>



If the second call comes in again, you can still forward it.

### 3.19 Canceling your second call and resuming the first call

You are in conversation with the second contact and the first contact is on hold.

Use one of the following methods:	
	You or the second contact hangs up.
<i>End</i>	Press the soft key with the following label: <i>End</i> .
Resume the call on hold:	
<i>Resume</i>	Press the soft key with the following label: <i>Resume</i> . The call with your first contact is resumed.

### 3.20 Switching between calls

During a conversation, a second call is on hold.	
Use one of the following methods:	
<i>Swap</i>	Press the soft key with the following label: <i>Swap</i> .
	Press the Hold key.
	Press the account key that is defined as hold.

» You can talk to the first contact and the second contact is on hold.

### 3.21 Transferring a call

#### 3.21.1 Transferring a call to another contact on hold

During a conversation, a second call is on hold.	
Use one of the following methods:	
	Press the Transfer key. » The two contacts are connected.
<i>Transfer</i>	Press the soft key with the following label: <i>Transfer</i> . The two contacts are connected.



### 3.22 Placing a call on hold

During a conversation, you wish to place the call on hold and resume it later on the same phone.



To place the call on hold:

Use one of the following methods:	
	Press the Hold key.
<i>Hold</i>	Press the soft key with the following label: <i>Hold</i> .

To resume the call which is on hold.

Use one of the following methods:	
	Press the Hold key.
<i>Resume</i>	Press the soft key with the following label: <i>Resume</i>
	Press the account key that is defined as hold.



### 3.22.1 Transferring your call to another contact

During a conversation:	
Use one of the following methods:	
	Press the Transfer key. >> The current call is on hold.
<i>Transfer</i>	Press the soft key with the following label: <i>Transfer</i> >> The first call is on hold.
<i>New</i> →  or <i>Call</i>	Call a new contact by using the dialer and dialing by name from the call log or directory. Your contact answers the call.
Use one of the following methods:	
	Press the Transfer key. >> The two contacts are connected.
<i>Transfer</i>	Press the soft key with the following label: <i>Transfer</i> >> The two contacts are connected.

Transfer between two external calls depends on the regulations of countries concerned and the server configuration.

### 3.22.2 Blind transfer

You can also immediately transfer your call, without having to wait for your contact to answer.

During a conversation:	
Use one of the following methods:	
	Press the Transfer key. >> The current call is on hold.
<i>Transfer</i>	Press the soft key with the following label: <i>Transfer</i> >> The first call is on hold.
<i>New</i> →  or <i>Call</i>	Call a new contact by using the dialer and dialing by name from the call log or directory.
<i>Blind transfer</i>	Before your contact answers the call, select B transf. >> The two contacts are connected.

Transfer between two external calls depends on the regulations of countries concerned and the server configuration.

### 3.23 Three-party conference

During a conversation, a second call is on hold.

Use one of the following methods:

	Press the Conf key. >> You are in conference mode.
<i>Conf</i>	Press the soft key with the following label: <i>Conf</i> >> You are in conference mode.

#### 3.23.1 End conf

You are in conference mode.

Use one of the following:

	Press the On-Hook key. >> The conference is ended.
<i>End</i>	Press the soft key with the following label: <i>End conf</i> >> The conference is ended.

#### 3.23.2 Leaving your two contacts talking together after the conference

You are in conference mode.



Use one of the following:

	Press the Transfer key. >> The two participants remain on the call.
<i>Transfer</i>	Press the soft key with the following label: <i>Transfer</i> >> The two participants remain on the call.

### 3.24 Six-party conference

You are in a three-party conference call.

Use one of the following methods:

	Press the Hold key.
<i>Hold</i>	Press the soft key with the following label: <i>Hold</i> .
<i>New</i> →  or <i>Call</i>	Call a new participant by using the dialer and dialing by name from the call log or directory. You are in conversation with the new participant.
<i>Join</i>	The new participant is joining the conference call.

When the maximum of participants is reached, you will not be able to make a new call to add a new participant.

Six-party conference depends on PBX, and is not supported on OXE SEPLOS.





### 3.24.1 End conf

You are in conference mode.	
Use one of the following methods:	
	Press the On-Hook key. >> The conference is ended.
<i>End conf</i>	Press the soft key with the following label: <i>End conf</i> >> The conference is ended.

If you are a participant (you did not initiate the conference call), you can exit the conference by pressing the On-Hook key.



### 3.25 Hiding your phone number

You can choose to hide your identity when making a call.

The phone is in idle state:	
<i>Menu</i>	Press the Menu soft key to access the Main Menu.
<i>Features</i>	Use up-down and "OK" navigation keys to select: <i>Features</i> .
<i>Anonymous</i>	Use up-down and "OK" navigation keys to select: <i>Anonymous</i>
	Select the SIP account whose phone number will be hidden.
<i>Switch</i> or 	Enable the <i>Anonymous</i> option, and enter the relevant server-supported feature code.
 or <i>Save</i>	Validate your choice
	End the settings.



### 3.26 Rejecting anonymous calls

The phone is in idle state:	
<i>Menu</i>	Press the Menu soft key to access the Main Menu.
<i>Features</i>	Use up-down and "OK" navigation keys to select: <i>Features</i> .
<i>Anonymous rejection</i>	Use up-down and "OK" navigation keys to select: <i>Anonymous rejection</i> .
	Select the corresponding SIP account.

<i>Switch</i> or 	Enable the option: <i>Anonymous rejection</i> , and enter the relevant server-supported feature code.
 or <i>Save</i>	Validate your choice
	End the settings.

### 3.27 Do not disturb (DND)

You can make your phone temporarily unavailable for all calls.



The phone is in idle state:	
<i>Menu</i>	Press the Menu soft key to access the Main Menu.
<i>Features</i>	Use up-down and "OK" navigation keys to select: <i>Features</i> .
<i>DND</i>	Use up-down and "OK" navigation keys to select: <i>DND</i> .
<i>Switch</i> or 	Enable the DND option.
 or <i>Save</i>	Validate your choice
	End the settings.

To disable the DND feature, follow the same procedure. You can also program a key on the homepage to have a direct access to this feature.



### 3.28 Call Forward

When you are absent or already in a call, you can forward all your calls to a defined number. You can program a key to activate the Call Forward feature.

The phone is in idle state:	
<i>Menu</i>	Press the Menu soft key to access the Main Menu.
<i>Features</i>	Use up-down and "OK" navigation keys to select: <i>Features</i> .
<i>Call Forward</i>	Use up-down and "OK" navigation keys to select: <i>Call Forward</i> .
Select the type of call forwarding:	
<i>Always Forward</i>	All your calls are immediately forwarded to a defined number.
<i>Busy Forward</i>	All your calls are forwarded to a defined number when you are already on the line.
<i>No Answer Forward</i>	All your calls are forwarded to a defined number when you are unable to answer.

 <i>Switch</i> or	Enable the Call Forward feature.
<i>Transfer</i>	Enter the number.
 or <i>Save</i>	Validate your choice
	End the settings.



### 3.29 Canceling call forwarding

The phone is in idle state:	
<i>Menu</i>	Press the Menu soft key to access the Main Menu.
<i>Features</i>	Use up-down and "OK" navigation keys to select: <i>Features</i> .
<i>Call Forward</i>	Use up-down and "OK" navigation keys to select: <i>Call Forward</i> .
Select the type of call forwarding to cancel:	
<i>Always Forward</i>	All your calls are immediately forwarded to a defined number.
<i>Busy Forward</i>	All your calls are forwarded to a defined number when you are already on the line.
<i>No Answer Forward</i>	All your calls are forwarded to a defined number when you are unable to answer.
 <i>Switch</i> or	Disable the Call Forward feature.
 or <i>Save</i>	Validate your choice.
	End the settings.

### 3.30 Listening to your voice messages

This feature depends on the PBX configuration. If necessary, contact your system administrator.

The message key flashes when you have received a new voice message or if you have missed calls.



	Press the message key. The number of voice messages received or calls missed is displayed on the screen.
<i>X new voice message(s)</i>	Use up-down and "OK" navigation keys to access voicemail.
	The number of new voice messages is displayed for each registered account. Select the relevant account.
 or <i>Enter</i>	Call your voicemail. Follow the voice guidance to listen to your voice messages from the voicemail server.

You can use the menu to access voicemail: *Menu* → *Voicemail* → *View Voice Messages*.

### 3.31 Defining a hotline number

If configured, the hotline number is dialed immediately or after a defined time delay when you pick up the handset or press the handsfree button or the Call button of the headset.

Refer to the following requirements to configure a hotline number:

The phone is in idle state:	
<i>Menu</i>	Press the Menu soft key to access the Main Menu.
<i>Features</i>	Use up-down and "OK" navigation keys to select: <i>Features</i> .
<i>Hotline</i>	Use up-down and "OK" navigation keys to select: <i>Hotline</i> .
<i>Number</i>	Enter a hotline number.
<i>Delay</i>	Enter the time delay in seconds before the hotline number is dialed. The hotline number is immediately dialed if the delay is not configured.
<i>Switch</i> or 	Enable the Hotline feature.
 or <i>Save</i>	Validate your choice.
	End the settings.

Follow the same procedure to deactivate the Hotline feature. This feature can also be configured on the Web Based Management page.

# 4 Doing more with your desk phone

Your desk phone is designed to evolve with the environment. It can do more than just establishing communication between people or helping you keep in touch with your contacts and enterprises. This section describes some use cases with your desk phone.

## 4.1 Configuring your desk phone for remote working

Your IP phone can be used for remote working (VPN) via a secure connection (encrypted). Please note that ALE-2/ALE-3 does not support the IPSec VPN, but only the OpenVPN.

A Virtual Private Network (VPN) is a technology that allows a device to create a tunneling connection to a server and become part of the enterprise's network (VPN server's network). VPN tunnels are secured via phone OpenVPN client with TLS authentication, credentials, and certificates.

To establish a VPN connection, make sure you have the following connection information from the host provider:

- Connection settings: server address, port, and protocol.
- CA root certification file (.crt).
- Client certification file (.crt).
- Client key file (.key).

The VPN connection must be configured, enabled, and disabled on the Web Based Management page.

- Open the Web Based Management page.

When the desk phone is connected to the network, your administrator can access the Web Based Management page via a web browser by entering the IP address of your desk phone. The administrator password of the phone is requested.

The screenshot displays the 'Web Based Management | ALE-2' interface. On the left is a navigation menu with options: Accounts, Network, Account, Network, IP Parameters, Port, LLDP, OpenVPN (highlighted), Provision, and Phone Keys. The main content area is titled 'OpenVPN' and contains the following configuration fields:

- Enable:** A toggle switch currently turned off.
- Server Address:** A text input field containing '0.0.0.0'.
- Server Port:** A text input field containing '1194'.
- Transport Protocol:** A dropdown menu set to 'UDP'.

Below these fields is a 'Submit' button. Underneath is a section for 'Upload Customer Certificate' with three rows:

- CA Certificate:** Input field, 'Select' button, 'Upload' button, 'Remove' button.
- VPN Certificate:** Input field, 'Select' button, 'Upload' button, 'Remove' button.
- VPN Key Certificate:** Input field, 'Select' button, 'Upload' button, 'Remove' button.

On the right side, there is a 'NOTES' section with the text 'OpenVPN settings.' and a copyright notice at the bottom: '© Copyright ALE International 2020'.

- In the left-side navigation pane, select OpenVPN.
- On the OpenVPN page, enter the required information (VPN server address, port, and protocol).
- Upload security files: click the Select button to select security files (CA root certification file, client certification file, and client key file) and then click the Upload button to upload them.
- Enable VPN.
- Click Submit.
- The desk phone restarts.

The connection will be established every time the system reboots until you manually disable the VPN.

To disable VPN:

- Open the Web Based Management page.
- In the left-side navigation pane, select OpenVPN.
- Disable VPN.
- Click Submit.
- The desk phone restarts.

## 4.2 Hot Desking

This feature allows you to use any compatible SIP desk phones in your company with your own phone number. When you activate your account on a desk phone, your entire phone configuration will be retrieved: local directory, history (requiring server support). After reboot, the phone restores its initial configuration.



We recommend activating only one phone number at a time to ensure that all incoming calls are received on the same phone.

This feature must be activated by the administrator of the desk phone.

Before using this feature, you must program a key on the desk phone for the feature: *Hot Desking*.

### 4.2.1 Log on to Hot Desking

When you start the Hot Desking feature, all user configurations on the desk phone are cleared.

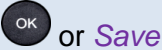
	Select the Hot Desking programmed key.
<i>OK</i>	Confirm that all current user configurations will be cleared.
	Enter the phone number and password of your SIP account.
	Confirm. The desk phone automatically loads the SIP account configuration. You can use the desk phone with your own account.

### 4.2.2 Log off from Hot Desking



When you want to leave the office and restore the initial state of the desk phone, you have to logout and reboot the phone.

# 5 Customizing your desk phone

## 5.1 Adjusting the audio features

The features described in this section can also be configured on the Web Based Management page.



### 5.1.1 Selecting the ringing

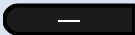
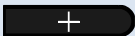

When the desk phone is in idle state:	
<i>Menu</i>	Press the Menu soft key to access the Main Menu.
<i>Basic Setting</i>	Use up-down and "OK" navigation keys to select: <i>Basic Setting</i> .
<i>Sound</i>	Use up-down and "OK" navigation keys to select: <i>Sound</i> .
<i>Ringing</i>	Use up-down and "OK" navigation keys to select: <i>Ringing</i> .
<i>Int Melody/Ext Melody</i>	Select the melodies for external and internal calls: <i>Int Melody/Ext Melody</i> .
	Select your melody (16 embedded melodies in total).
 or <i>Enter</i>	Validate your choice.
	End the procedure.

### 5.1.2 Adjusting the ringing volume

When the desk phone is in idle state:	
 	Select the volume you want (10 levels in total).



### 5.1.3 Configuring the ring mode

When the desk phone is in idle state:	
<i>Menu</i>	Press the Menu soft key to access the Main Menu.
<i>Basic Setting</i>	Use up-down and "OK" navigation keys to select: <i>Basic Setting</i> .
<i>Sound</i>	Use up-down and "OK" navigation keys to select: <i>Sound</i> .
<i>Ringing</i>	Use up-down and "OK" navigation keys to select: <i>Ringing</i> .
<i>Ring mode</i>	Use up-down and "OK" navigation keys to select: <i>Ring mode</i> .
<i>Switch</i> or 	<ul style="list-style-type: none"> <li><i>Normal ringing</i> A normal ring signals an incoming call.</li> <li><i>Progressive ringing</i> A progressive ring signals an incoming call.</li> </ul>
<i>Switch</i> or 	Enable or disable the silent mode: <i>Silent mode</i> .

	The desk phone no longer rings, but the LED flashes continuously to signal an incoming call.
 or <i>Save</i>	Validate your choice.
	End the procedure.

### 5.1.4 Configuring the beep mode

When the desk phone is in idle state:



<i>Menu</i>	Press the Menu soft key to access the Main Menu.
<i>Basic Setting</i>	Use up-down and "OK" navigation keys to select: <i>Basic Setting</i> .
<i>Sound</i>	Use up-down and "OK" navigation keys to select: <i>Sound</i> .
<i>Ringing</i>	Use up-down and "OK" navigation keys to select: <i>Ringing</i> .
<i>Beep</i>	Use up-down and "OK" navigation keys to select: <i>Beep</i> .
<i>Switch</i> or 	<ul style="list-style-type: none"> <li>• <i>0 Beep</i>: A normal ring signals an incoming call.</li> <li>• <i>1 Beep</i>: A beep followed by the ring signals an incoming call.</li> <li>• <i>3 Beeps</i>: Three beeps followed by the ring signals an incoming call.</li> </ul>
 or <i>Save</i>	Validate your choice.
	End the procedure.

### 5.1.5 Configuring the seat mode



Your desk phone supports the seat mode, which is a different ring mode. The seat mode allows your administrator to switch the ringing onto the loudspeaker, the headset, or both. This feature can be configured on the Web Based Management page.

## 5.2 Selecting a language



When the desk phone is in idle state:

<i>Menu</i>	Press the Menu soft key to access the Main Menu.
<i>Basic Setting</i>	Use up-down and "OK" navigation keys to select: <i>Basic Setting</i> .
<i>Languages</i>	Use up-down and "OK" navigation keys to select: <i>Languages</i> .
<i>Switch</i> or 	Select the language of your choice.
 or <i>Save</i>	Validate your choice.
	End the procedure.

## 5.3 Adjusting the brightness of the desk phone

When the desk phone is in idle state:	
<i>Menu</i>	Press the Menu soft key to access the Main Menu.
<i>Basic Setting</i>	Use up-down and "OK" navigation keys to select: <i>Basic Setting</i> .
<i>Display</i>	Use up-down and "OK" navigation keys to select: <i>Display</i> .
<i>Backlight</i>	Use up-down and "OK" navigation keys to select: <i>Backlight</i> .
Use left-right navigation keys to adjust the brightness.	
<i>Active Level</i>	Adjust the brightness when the desk phone is active.
<i>Inactive Level</i>	Adjust the brightness when the desk phone is inactive.
<i>Backlight Time</i>	Set the duration for the desk phone backlight.
<i>Switch</i> or 	Set the duration for the backlight.
 or <i>Save</i>	Validate your choice.
	End the procedure.



## 5.4 Enabling the Screen Saver and defining the Wait Time

When the desk phone is in idle state:	
<i>Menu</i>	Press the Menu soft key to access the Main Menu.
<i>Basic Setting</i>	Use up-down and "OK" navigation keys to select: <i>Basic Setting</i> .
<i>Display</i>	Use up-down and "OK" navigation keys to select: <i>Display</i> .
<i>Screen Saver</i>	Use up-down and "OK" navigation keys to select: <i>Screen Saver</i> .
<i>Screen Saver</i>	Enable the Screen Saver and define the Wait Time (use left-right navigation keys).
<i>Wait Time</i>	Enter the wait time in seconds before the screen saver starts.
 or <i>Save</i>	Validate your choice.
	End the procedure.



## 5.5 Configuring the wall paper (ALE-3)

When the desk phone is in idle state:	
<i>Menu</i>	Press the Menu soft key to access the Main Menu.
<i>Basic Setting</i>	Use up-down and "OK" navigation keys to select: <i>Basic Setting</i> .
<i>Display</i>	Use up-down and "OK" navigation keys to select: <i>Display</i> .
<i>Wallpaper</i>	Choose the default built-in picture to change the idle screen wallpaper.

## 5.6 Configuring the homepage format

When the desk phone is in idle state:	
<i>Menu</i>	Press the Menu soft key to access the Main Menu.
<i>Basic Setting</i>	Use up-down and "OK" navigation keys to select: <i>Basic Setting</i> .
<i>Display</i>	Use up-down and "OK" navigation keys to select: <i>Display</i> .
<i>Homepage</i>	Use left-right navigation keys or the Switch key to select a display mode for the homepage.
 or <i>Save</i>	Validate your choice.
	End the procedure.



## 5.7 Defining the voicemail number

When the desk phone is in idle state:	
<i>Menu</i>	Press the Menu soft key to access the Main Menu.
<i>Voicemail</i>	Use up-down and "OK" navigation keys to select: <i>Voicemail</i> .
<i>Set Voicemail Number</i>	Use up-down and "OK" navigation keys to select: <i>Set Voicemail Number</i> .
	Enter the voicemail number of the corresponding account.
 or <i>Save</i>	Validate your choice.
	End the procedure.



## 5.8 Programmable keys

With the ALE-2/ALE-3 Basic DeskPhone, you can program the keys to the right of LCD to 8/12 virtual programmable keys.

### 5.8.1 Creating a programmable key

	Long press on a programmable key (on the right of the screen).
 or <i>Switch</i>	Define the type of the programmable key. Depending on the type of the key, fill in the options.
 or <i>Save</i>	Save the programmable key.

## 5.8.2 Deleting a programmable key

	Long press on a programmable key (on the right of the screen).
 or <i>Switch</i>	Use the left-right navigation keys to switch to the Undefined option.
 or <i>Save</i>	Save to delete the programmable key.

## 5.8.3 Type of supported programmable keys

- *Undefined*: delete a programmable key.
- *Account*: line key.
  - *Account*: select the relevant SIP account.
  - *Label*: enter the label of the line key, displayed on the homepage.
- *Speed Dial*: speed dial key (direct call key).
  - *Account*: select the relevant SIP account.
  - *Label*: enter the label of the Speed Dial key, displayed on the homepage.
  - *Value*: enter the number you want to dial immediately.
- *BLF (Busy Lamp Field)*: indicates whether a specific account connected to the same system is busy or not. Use the BLF key to make a direct call or pick up a call.
  - *Account*: select the relevant SIP account.
  - *Label*: enter the label of the BLF key, displayed on the homepage.
  - *Value*: the number of the extension which the user wants to monitor.
  - *Extension*: a list of extensions which the user wants to monitor.
- *BLF List*: a list of extensions which the user wants to monitor. The list is defined by your administrator on the Web Management page or a configuration file.
  - *Account*: select a specific SIP account to monitor extensions of that account.
- *Hold*: place the current call on hold.
  - *Label*: enter the label of the Hold key, displayed on the homepage.
- *Transfer*: transfer the current call.
  - *Label*: enter the label of the Transfer key, displayed on the homepage.
  - *Value*: the number to be transferred.
- *Conference*: conference call feature.
  - *Label*: enter the label of the Conf key, displayed on the homepage.
  - *Value*: the number of the caller who wants to initiate a conference call.
- *DND*: do not disturb feature.
  - *Label*: enter the label of the DND key, displayed on the homepage.
- *Redial*: redial the last outgoing number.
  - *Label*: enter the label of the Redial key, displayed on the homepage.
- *Directory*: local directory.
  - *Label*: enter the label of the Directory key, displayed on the homepage.
- *Forward*: immediate forward to a number.
  - *Label*: enter the label of the Forward key, displayed on the homepage.
  - *Value*: enter the destination number.
- *Voicemail*: connect to the voicemail to obtain voice messages.
  - *Account*: select the relevant SIP account.
  - *Label*: enter the label of the Voicemail key, displayed on the homepage.
  - *Value*: enter the voicemail prefix code.

- **Hot Desking:** desk sharing feature.
  - **Label:** enter the label of the Hot Desking key, displayed on the homepage.
- **Prefix:** enter the predefined prefix when you start dialing.
  - **Account:** select the relevant SIP account.
  - **Label:** enter the label of the Prefix key, displayed on the homepage.
  - **Value:** prefix.
- **DTMF:** send a predefined DTMF digits during conversation.
  - **Label:** enter the label of the DTMF key, displayed on the homepage.
  - **Value:** DTMF code.
- **DirectPickup:** call pickup.
  - **Account:** select the relevant SIP account.
  - **Label:** enter the label of the DirectPickup key, displayed on the homepage.
  - **Value:** enter the pickup code followed by the extension number.
- **GrpPickup:** group call pickup.
  - **Account:** select the relevant SIP account.
  - **Label:** enter the label of the GrpPickup key, displayed on the homepage.
  - **Value:** enter the group pickup code followed by the extension number.
- **Headset:** activate/deactivate the headset mode.
  - **Label:** enter the label of the Headset key, displayed on the homepage.
- **GroupListen:** activate/deactivate the group listening mode.
  - **Label:** enter the label of the GroupListen key, displayed on the homepage.
- **Intercom:** make a call to a contact who will automatically answer the call.
  - **Account:** select the relevant SIP account.
  - **Label:** enter the label of the Intercom key, displayed on the homepage.
  - **Value:** enter the contact number to call.
- **XML Browser:** display an XML page.
  - **Label:** enter the label of the XML Browser key, displayed on the homepage.
  - **Value:** enter the URL of the XML page.
- **Phone Lock:** lock/unlock the phone.
  - **Label:** enter the label of the Phone Lock key, displayed on the homepage.

Programmable keys can also be configured by the administrator on the Web Management page or via a configuration file.

LED behavior may differ depending on the desk phone configuration.

For more information, contact your administrator.

## 5.9 Call pick-up

If authorized, you can answer calls of a specific account that no one answers on your own telephone.

The server can be configured to prevent call pick-up on some telephones.

Before using this feature, you must program a key on the homepage for the following feature:

*DirectPickup* or *GrpPickup*

- If the phone ringing is in your own pick-up group, select the programmed key: *GrpPickup*.
- If the phone ringing is not in your pick-up group, select the programmed key: *DirectPickup*.

## 5.10 Activating the headset mode

You can use a headset with your desk phone. If you want the headset to ring only when receiving an incoming call, you must activate the headset mode.

Before using this feature, you must press the headset key to activate the headset feature. When the feature is activated, the LED of the headset is on and shows a blue light.

When the desk phone is in idle state:

Connect the headset to the desk phone





Press the *Headset* key.

This icon is displayed on your desk phone screen: 

## 5.11 Defining Time and Date format

When the desk phone is in idle state:

<i>Menu</i>	Press the Menu soft key to access the Main Menu.
<i>Basic Setting</i>	Use up-down and "OK" navigation keys to select: <i>Basic Setting</i> .
<i>Time and Date</i>	Use up-down and "OK" navigation keys to select: <i>Time &amp; Date</i> .
	<i>Date</i> : use the left-right navigation keys to select a date format. There are 6 date formats: YY-MM-DD, YYYY/MM/DD, YY/MM/DD, YYYY MM DD, YYYY-MM-DD, and MM DD WW
	<i>Time</i> : use the left-right navigation keys to select a time format. There are two time formats: 12-hour clock and 24-hour clock.
 or <i>Save</i>	Validate your choice.

## 5.12 Energy saving

Desk phones are designed to consume as little energy as possible. By following these tips, you can help to reduce your phone's energy consumption and be more eco-friendly.

- Reduce the screen brightness to a low level when the phone is idle.
- Activate the screensaver with a quick wait period to conserve energy.

# 6 Contacting your administrator (technical support)

If necessary, you may need to contact your administrator.

Before contacting your administrator, make sure you have information such as your desk phone's codes and software version.

## 6.1 Technical code / Date code

The codes are located on the back shell. This label is an example and does not represent the one placed on your desk phone.

- 1 Technical code (ordering code)  
MAC information and date code

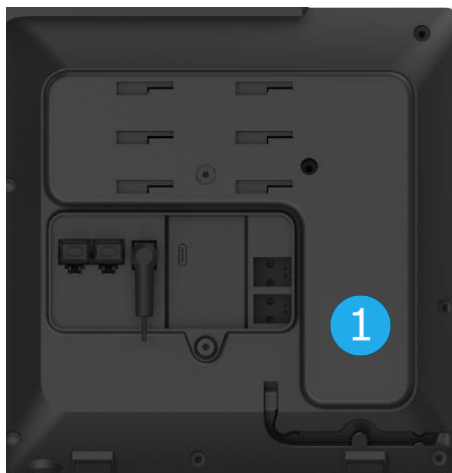

## 6.2 Viewing the software version/network settings (IP address)

The software version can be viewed on the phone by using the following methods:

When the desk phone is in idle state:	
Use one of the following methods:	
	Display the current IP and MAC addresses and software version of the desk phone.
<i>Menu → Status</i>	Display the current IP and MAC addresses and software version of the desk phone.

## 6.3 Accessing administrator configuration

### 6.3.1 Default password

The default password for the advanced settings of the desk phone is "123456".

The default user name and password for accessing the Web Based Management is "admin" and "123456".

When connecting for the first time, the desk phone will prompt the user to modify the default password.

### 6.3.2 Advanced Settings

The Advanced Setting menu allows the administrator to set SIP accounts, configure wireless networks, configure automatic deployment, change the password, and view IP parameters and certificates. The administrator can also restore factory settings of the desk phone by using that menu.

When the desk phone is in idle state:

<i>Menu</i>	Press the Menu soft key to access the Main Menu.
<i>Advanced Settings</i>	Use up-down and "OK" navigation keys to select: <i>Advanced Setting</i> .
<i>&lt;123&gt;</i>	Enter the administrator password.

### 6.3.3 Web Based Management (WBM)

Web Based Management offers the administrator an easy way to configure the settings of your desk phone. Through a web based management service hosted by your desk phone, the administrator can manage and configure your phone.

When your desk phone is connected to the network, the administrator can access the Web Based Management via a web browser by entering the IP address of the phone through HTTPS.

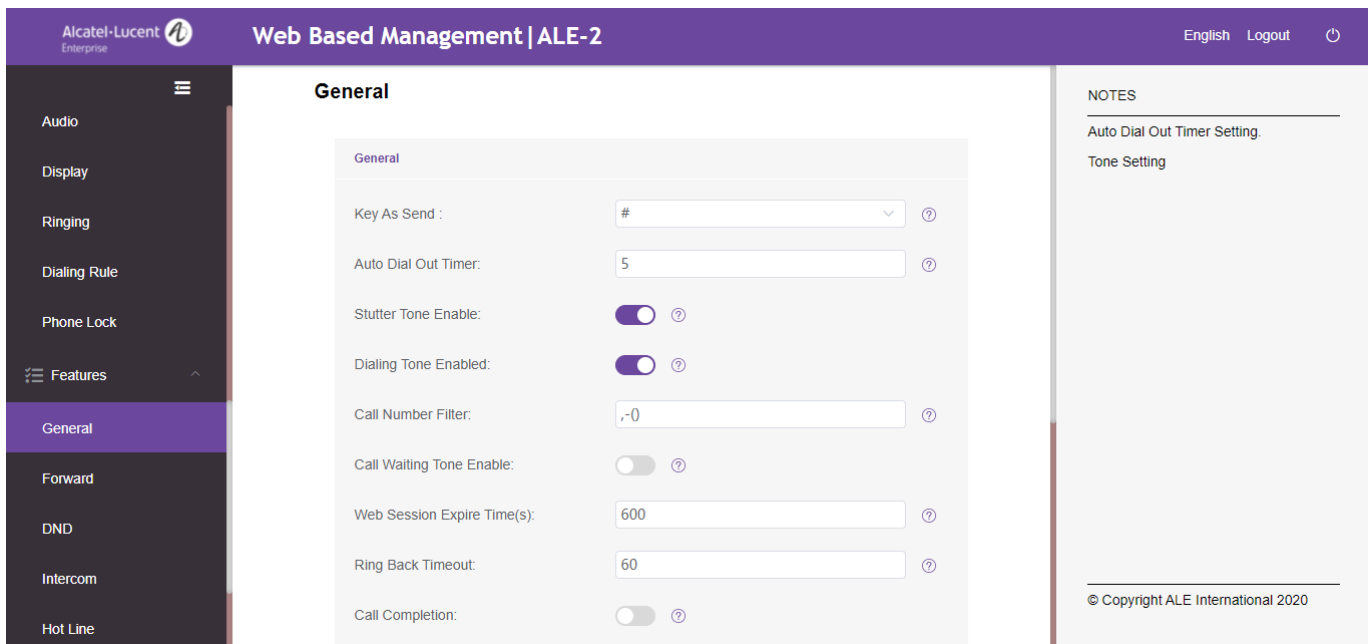

Through the Web Based Management, your administrator can configure all SIP accounts of the desk phone.

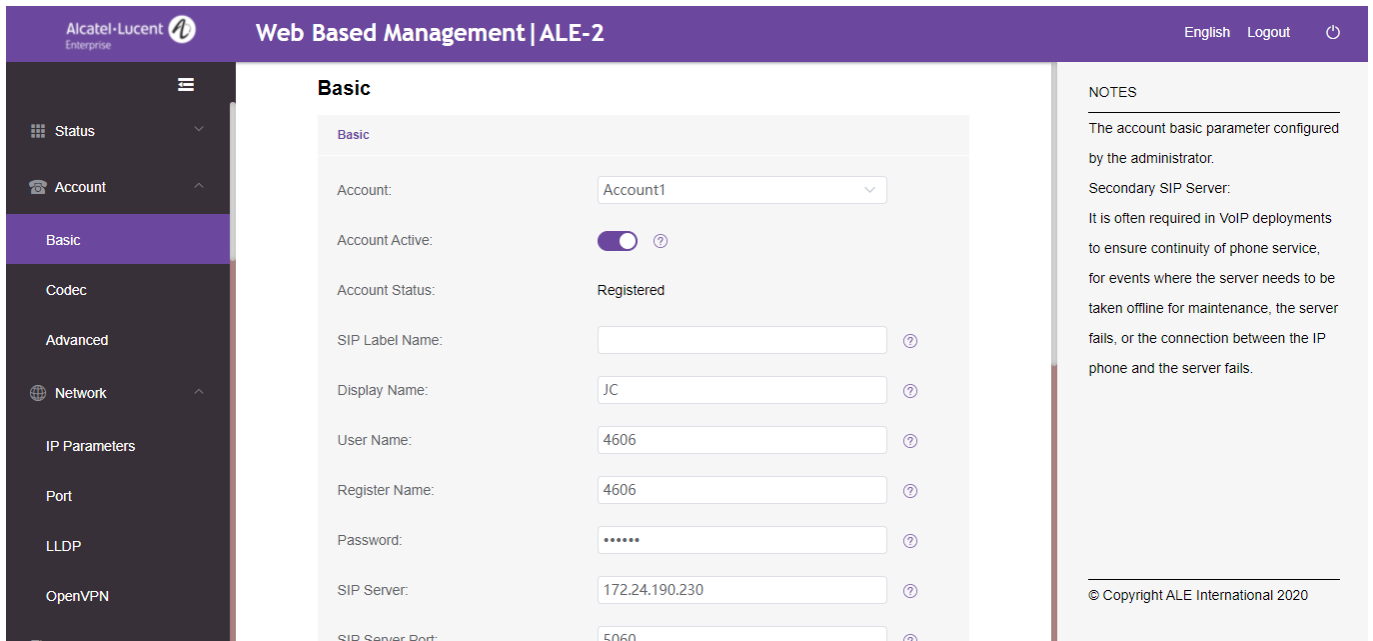

The administrator can also define the programmable keys and dynamic program keys displayed on the homepage.

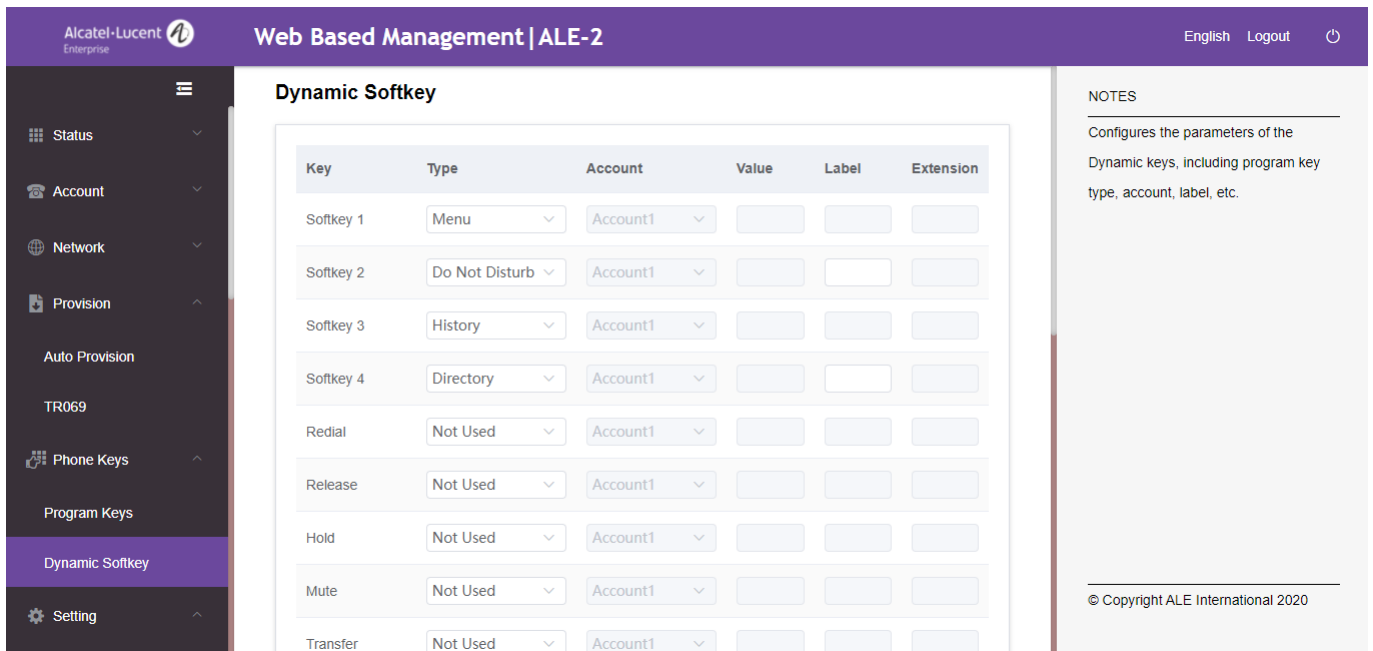

All configuration parameters of the desk phone can be managed on the Web Management page.

- Audio (ringing, dial tone...)
- Backlight, Screen Saver, Auto Lock
- Date Format, Time Format
- Call Forward, DND
- Hotline
- Intercom
- Programmable keys
- Network Configuration (DM, DNS, Ethernet, IP param, LDAP...)
- VPN Configuration
- ...

# 7 Accessories

The ALE-supported accessories are intended to work smoothly on our clients (hardphones, softphones). The list of accessories presented in this document is not contractually binding and can be modified without prior notice.

## 7.1 Headset

You can use an ALE RJ9 headset to handle calls on ALE-2, and use an ALE RJ9/USB headset to handle calls on ALE-3. To know more information about headsets, please contact your administrator or refer to the Alcatel-Lucent Enterprise website. The following headsets have gone through stringent tests and are compatible with ALE-2/ALE-3:

RJ9 headset (ALE-2/ALE-3)	Alcatel-Lucent Enterprise AH 11 GA Headset Monaural RJ9
	Alcatel-Lucent Enterprise AH 12 GA Headset Binaural RJ9
USB headset (ALE-3)	Alcatel-Lucent Enterprise AH 11 U Headset Monaural USB-A
	Alcatel-Lucent Enterprise AH 12 U Headset Binaural USB-A
	Alcatel-Lucent Enterprise AH 21 U Premium Headset Monaural USB-A
	Alcatel-Lucent Enterprise AH 22 U Premium Headset Binaural USB-A
	Alcatel-Lucent Enterprise AH 22 M Premium Headset Binaural USB-A
	Alcatel-Lucent Enterprise AH 21 U II Premium Headset Monaural USB-A
	Alcatel-Lucent Enterprise AH 22 U II Premium Headset Binaural USB-A
	Alcatel-Lucent Enterprise AH 21 M II Premium Headset Monaural USB-A
	Alcatel-Lucent Enterprise AH 22 M II Premium Headset Binaural USB-A

## 7.2 Wall mounting kit

To mount your phone on the wall, you need to install a standard wall plate that you can easily find on the market. Follow the manufacturer's instructions to install the wall plate on the wall. When the wall plate is fixed, you can prepare your phone and mount it on the wall. The wall mounting kit is sold separately (refer to Section 9 for ordering information).

## 7.3 Ethernet cable

Ethernet Cable	Alcatel-Lucent 2 pairs Straight Telephone Network cable CAT3 UTP-RJ11 to RJ45 - RJ11M 6P4C - RJ45M 8P4C- Length 3m (x10)
----------------	--

## 8 Technical specifications

Parameters	ALE-2 Basic DeskPhone	ALE-3 Basic DeskPhone
Width	214 mm	214 mm
Length	191 mm	191 mm
Height	47 mm	47 mm
Weight	795 g	805g
Angel of the support foot	45° / 50°	45° / 50°
Color	Gray	Gray
Display	2.8-inch black-and-white display with backlight, 132 x 64 pixels	2.8-inch color display with backlight, 320 x 240 pixels
Line key	3	4
Headset interface	RJ9	RJ9/USB-A
Ethernet ports	Dual 1000 Mbps Ethernet ports	Dual 1000 Mbps Ethernet ports
Power over Ethernet (IEEE 802.3af)	Class 1	Class 2
Power consumption (PoE) Idle – Active (no accessory)	0.98W-3.2W	1.1W-4.6W
External power supply (accessory)	5V/2A	5V/2A
Working temperature	-5°C to +45°C	-5°C to +45°C
Storage/transportation temperature	-25°C to +70°C	-25°C to +75°C

## 9 Ordering information

Model Name	Part Number
ALE-2 Basic SIP Phone	3MK27013AA
ALE-3 Basic SIP Phone	3MK27017AA
ALE-2/ALE-3 Wall Mounting Kit	3MK27015AA
ALE-2/ALE-3 Power Supply Europe	3MK37001AA
ALE-2/ALE-3 Power Supply US	3MK37001US
ALE-2/ALE-3 Power Supply UK	3MK37001UK
ALE-2/ALE-3 Power Supply AU	3MK37001AU

# 10 Guarantee and clauses

## 10.1 Safety instructions

- Changes or modifications to the equipment not expressly approved by the party responsible for compliance could void the user's authority to operate the equipment.
- Magnets could affect the functioning of pacemakers and implanted heart defibrillators. Keep a safe distance between your pacemaker or implant defibrillator and the handset which includes magnetic elements: 4 centimeters (1,6 inches) at least.
- To limit the risk of interference, people with pacemakers must keep the wireless telephone away from their equipment (minimum distance of 15 cm/6 inches).
- It is recommended to follow the standard acceptance procedures before using this equipment in human safety critical areas (hospitals...).
- The handset includes magnetic elements that may attract sharp metallic objects. To prevent injury, before each use ensure sharp metallic objects are not stuck to the earpiece and microphone.
- Avoid using phones (other than cordless type) during an electrical storm. There may be a remote risk of electric shock from lightning.
- Do not use the device in environments where there is a danger of explosion.
- Do not plug this phone into an Integrated Services Digital Network (ISDN) connection or into a regular Public Switched Telephone Network (PSTN) connection. This can result in severe damage to the phone.
- Never allow your telephone to come into contact with water. To clean your telephone, use a soft damp cloth. Never use solvents (trichlorethylene, acetone, etc.) which may damage the plastic parts of your telephone. Do not use aerosol cleaners.

ALE-3/ALE-2 DeskPhone: This product is intended to be supplied, either via the Ethernet (LAN) port (DeskPhone ALE-2: minimum Class 1 according to IEEE802.3af, DeskPhone ALE-3: minimum Class 2 according to IEEE802.3af), or via the DC-in by a Certified Direct Plug-In Power Unit approved as 'LPS' (Limited Power Source) against IEC/UL/CSA 62368-1 and rated 5V dc, minimum 2A. Other power supply products from the same family are permitted: F12L20-050200SPA – Chenzhou Frecom Electronic Co., LTD.

If you are connected to a POE connection do not use an external Power Supply.

The PoE (Power over Ethernet) devices that supply or receive power and their connected cables must all be completely indoors.

### Regulatory Statements

Declaration of Conformity may be obtained from:

ALE International 32 avenue Kléber – 92700 Colombes, France -

[www.al-enterprise.com/en/declaration-of-conformity](http://www.al-enterprise.com/en/declaration-of-conformity).

## EU Countries

This equipment complies with the essential requirements of the following directives:

- 2009/125/EC (ErP), 2011/65/EU (RoHS) and its amendment 2015/863(EU),
- Non-Radio equipment: 2014/30/EU (EMC), 2014/35/EU (LVD),
- Radio equipment: 2014/53/EU (RED)



## UK

This equipment is in compliance with the essential requirements of following regulations: Radio Equipment Regulations 2017, Electromagnetic Compatibility Regulations 2016, Electrical Equipment (Safety) Regulations 2016, The Ecodesign for Energy-Related Products and Energy Information (Amendment) (EU Exit) Regulations 2020, The Restriction of the Use of Certain Hazardous Substances in Electrical and Electronic Equipment Regulations 2012.

The 5150 to 5350 MHz frequency range is restricted to indoor use.

## Canada

Equipments with RF part comply with Industry Canada's license-exempt RSSs. Operation is subject to the following two conditions: (1) this device may not cause harmful interference, and (2) this device must accept any interference received, including interference that may cause undesired operation. These products meet the applicable Innovation, Science and Economic Development Canada technical specifications. The devices for the band 5150–5350 MHz are only for indoor usage to reduce potential for harmful interference to co-channel Mobile Satellite systems.

## USA

Equipment without RF part has been tested and found to comply with the limits for a class B digital device, pursuant to Part 15 of the FCC Rules. These limits are designed to provide reasonable protection against harmful interference in a residential installation. This equipment generates, uses and can radiate radio frequency energy and, if not installed and used in accordance with the instructions, may cause harmful interference to radio communications.

However, there is no guarantee that interference will not occur in a particular installation. If this equipment does cause harmful interference to radio or television reception, which can be determined by turning the equipment off and on, the user is encouraged to try correcting the interference by consulting the dealer. Privacy of communications may not be ensured when using any Bluetooth® device.



California - Warning: these products can expose you to chemicals including Lead and Lead Compounds, which are known to the State of California to cause cancer and birth defects or other reproductive harm. For more information, go to [www.P65Warnings.ca.gov](http://www.P65Warnings.ca.gov).

## User Instructions

Use this product in temperatures between -5°C to +45°C (23°F to 113°F). For use in an indoor environment only. This apparatus is Hearing Aid Compatible (HAC).

## Acoustic Shock Protection

Maximum sound pressure level for handset is compliant with European, US and Australian standards.

## Directive 2003/10/EC Specifying the Risks Inherent in Noise at Work

The ring contributes towards overall daily noise - at its maximum setting, the level is 105 dBA at 60 cm from terminal. To reduce the level, the following is recommended:- reduce the setting (9 levels of 5 dB) - program a progressive ring.

## Privacy

Privacy of communications may not be ensured when using any Bluetooth® device.

## Disposal



The equipment must be returned to a collection point for electronic equipment waste disposal.

## Energy Star

ENERGY STAR is a government-backed program aiding businesses and consumers in conserving energy and reducing costs. Its label is a trusted indicator that a product adheres to stringent energy efficiency criteria set by the U.S. Environmental Protection Agency (EPA). Alcatel-Lucent Enterprise proudly partners with ENERGY STAR. Our products are crafted to meet or surpass ENERGY STAR guidelines, promoting energy conservation, cost efficiency and environmentally conscious practices. The products detailed in this manual are ENERGY STAR certified. They are designed to consume less energy and be better for the environment. Refer to the following section for tips on using your desk phone efficiently: Energy saving.









## Related Documentation

Other languages for these Safety and Regulatory Instructions and User Documentation are available at the following website: <https://www.al-enterprise.com/products>.





The Alcatel-Lucent name and logo are trademarks of Nokia used under license by ALE.

### Function keys

	Take/redial the call key Display the dialing list, enter the dialing page, and select the last number dialed.
	Place a call on hold/recover the call
	Transfer a call
	Hook on Go back to the homepage
	Mute key Press this key to mute/unmute the microphone during a call
	Access the voicemail The message key flashes red when you have received a new voice message or missed an incoming call.
	Handsfree key Press this key to answer an incoming call in handsfree mode Press this key to make a call in handsfree mode Press this key to end a call Press this key to switch voice channel among handsfree, handset or headset mode during a call

### Icons

Icons provide information under a certain status or the status of a specific call.





	SIP account (idle state). A grayed or crossed icon means that the SIP account is not registered (please contact your administrator).
	Incoming call icon
	Call in progress icon
	Call on hold icon

### Alpha-numeric dialpad

The phone is equipped with an alphanumeric dialpad.  
Enter alphabetic characters: The number pad keys have letters that can be displayed by successive taps. The last character in the series is a number.

*Abc/ABC/  
Abc2ab/  
123* In a text zone, you can switch to the alphabetic dialpad by using this key.

Some special characters can be displayed by successively tapping the key:

	% \$ / ~ & ( ) [ ] = *
	@ #
	space - _ 1
	+ . , ; : \ ? ! 0



### Contacts management

<i>Directory</i>	Tap this soft key to enter the directory menu
<i>Back</i>	Return to the previous menu
<i>Call</i>	Call the selected contact
<i>Add</i>	Add a new contact to the local directory
<i>Detail</i>	View the contact information such as name and number, etc.
<i>Option</i>	Access more options for the selected contact
<i>Option → Delete</i>	Delete the selected contact
<i>Option → Delete all</i>	Delete all contacts in the local directory



### Call log







<i>History</i>	Access the call log
<i>Back</i>	Return to the previous menu
<i>Call</i>	Call the selected contact
<i>Delete</i>	Delete the selected entry Note that no confirmation is requested.
 or <i>Details</i>	Display the detailed information of selected item including caller name, number, and call time, etc.
<i>Option</i>	Access more features such as Add to Blacklist, Add to Contacts and Delete all

### Making a call

	Select the SIP account to make a call
	Enter the number
<i>abc</i> 	Call by name
<i>History</i>	Call from call log
<i>Directory</i>	Call from your directory

Use one of the following methods after entering the number:

	Press the Redial key Make a call in several ways: handset if unhooked, headset if connected, otherwise in handsfree mode
	Press the OK key to make a call Make a call in several ways: handset if unhooked, headset if connected, otherwise in handsfree mode
<i>Call</i>	Press the Call key to make a call Make a call in several ways: handset if unhooked, headset if connected, otherwise in handsfree mode
<i># or *</i>	Press the # or * key (depending on the phone setting <i>Menu → Features → Key As Send</i> ) to make a call

Receiving a call	
	Lift the handset to take the call
	Use the headset to take the call
	Press the Loudspeaker/Handsfree key to take the call in handsfree mode.
	Press the blinking line key associated with the SIP account.
<i>Take</i> or 	Take the call with the headset if connected, or in handsfree mode.
 or <i>Reject call</i>	Transfer the call to your voicemail.
<i>Forward</i>	Transfer the call to another contact.
During conversation	
<i>End</i>	End the call
<i>Hold</i>	Call holding
<i>Transfer</i>	Call transfer
<i>Resume</i>	Retrieve a call (on hold, parked)
<i>New</i>	Make a new call during a conversation
<i>Swap</i>	Switch between two calls
<i>Conf</i>	Establish a multi-party conference call
<i>End conf</i>	Exit the conference call as a participant or end the conference call for all participants as an organizer
	Toggle the microphone on or off
Basic settings	
<i>Menu</i>	Press the soft key settings.
<i>Basic Setting</i> → <i>Sound</i> → <i>Ring</i>	Select the melody Adjust the ringer volume Configuring the ring mode Configuring the beep mode
<i>Basic Setting</i> → <i>Sound</i> → <i>DTMF Tone</i>	To activate or deactivate the DTMF mode.
	Adjust the ringer volume
<i>Basic Setting</i> → <i>Language</i>	Selecting a language
<i>Basic Setting</i> → <i>Display</i>	Adjust the brightness when the phone is in use. Adjust the brightness when the phone is not in use. Set the delay before the screen saver starts.
<i>Status</i>	Display IP and MAC addresses and software version.
<i>Features</i>	Access phone features: Call Forward, DND, Auto Answer, Programmable Key, Anonymous, Key As Send, Hotline, Default Account, Intercom.
<i>Menu</i>	Press the soft key settings.

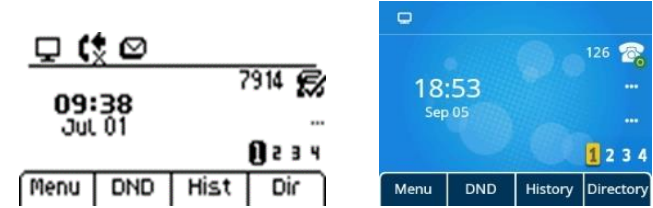
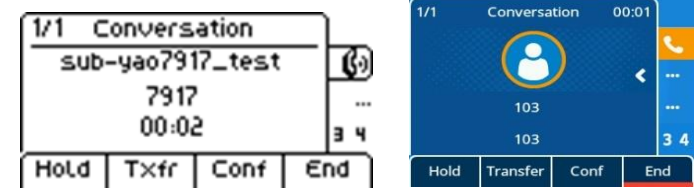
Homepage	
	
Soft keys	Use 4 soft keys at the bottom of the screen to access features, configure the phone, or manage calls.
Programmable keys	Use programmable keys on the right side of the screen to customize different features of the phone. Press the programmed key to use the corresponding feature (e.g., call contacts). Long press the programmed key to enter into the key configuration page.
Turn pages	Use the "1234" key at the lower right corner of the screen to turn pages (4 pages in total). Use the left-right navigation keys or the "1234" key to navigate between pages. The number of the displayed page is highlighted.
Status bar	Display the status information including the network status and phone status at the top of the screen.
Date and time	Default mode: Date and time in the middle of the screen. Extended mode: Date and time at the top right corner of the screen.
	<p><b>OK key:</b> Press this key to validate your choices while programming keys or configuring the phone or view the phone status in idle state.</p> <p><b>Left-right navigation key:</b> Use the key to move from one page to another in the homepage, move the cursor in a text box or move from one tab to another in different application.</p> <p><b>Up-down navigation key:</b> Use the key to select an option from a list.</p>
C key	<b>Cancel key:</b> Use this key to go back to the previous step.
Call management screen	
	
Soft keys	Soft keys on the lower part of the screen display different features available depending on the call status. Press the soft key to select the corresponding feature.
Call display screen	Call information such as the duration, number, and caller name is displayed in the middle of the screen.