



Emulex[®] Fibre Channel Host Bus Adapters

Installation Guide
Release 12.8

Broadcom, the pulse logo, Connecting everything, Avago Technologies, Avago, the A logo, Brocade, Emulex, LightPulse, and OneCommand are among the trademarks of Broadcom and/or its affiliates in the United States, certain other countries, and/or the EU.

Copyright © 2020–2021 Broadcom. All Rights Reserved.

The term “Broadcom” refers to Broadcom Inc. and/or its subsidiaries. For more information, please visit www.broadcom.com.

Broadcom reserves the right to make changes without further notice to any products or data herein to improve reliability, function, or design. Information furnished by Broadcom is believed to be accurate and reliable. However, Broadcom does not assume any liability arising out of the application or use of this information, nor the application or use of any product or circuit described herein, neither does it convey any license under its patent rights nor the rights of others.

Table of Contents

Chapter 1: Introduction	5
1.1 LPe36000-Series HBAs and LPe35000-Series HBAs	5
1.1.1 Major Features	5
1.1.2 Compatibility	6
1.1.3 Prerequisites	6
1.2 LPe32000-Series HBAs and LPe31000-Series HBAs	6
1.2.1 Major Features	7
1.2.2 Compatibility	7
1.2.3 Prerequisites	7
1.3 LPe16000-Series HBAs and LPe15004 HBAs	8
1.3.1 Major Features	8
1.3.2 Compatibility	8
1.3.3 Prerequisites	8
1.4 LPe12000-Series HBAs	8
1.4.1 Major Features	9
1.4.2 Compatibility	9
1.4.3 Prerequisites	9
1.5 LPe1250 HBAs	9
1.5.1 Major Features	9
1.5.2 Compatibility	10
1.5.3 Prerequisites	10
1.6 HBA Identification	10
1.7 Abbreviations	10
Chapter 2: Installation	11
2.1 Preparing the HBA for Installation	11
2.2 Installing the HBA	14
2.3 Attaching Media	14
2.4 Applying Power	19
2.4.1 Viewing the LEDs	19
2.4.2 POST Conditions and Results	20
2.5 Changing the PCI Device ID Jumper Setting	21
2.6 Special Features of LPe36000-Series HBAs, LPe35000-Series HBAs, LPe32000-Series HBAs, and LPe31000-Series HBAs	22
2.6.1 Changing the Speed of the HBA	23
2.6.2 Setting the Secure Firmware Jumper	23
Chapter 3: References	25
3.1 Specifications	25

3.1.1 LPe36000-Series HBAs and LPe35000-Series HBAs	25
3.1.2 LPe32000-Series HBAs and LPe31000-Series HBAs	26
3.1.3 LPe16000-Series HBAs and LPe15004 HBAs	27
3.1.4 LPe12000-Series HBAs and LPe1250 HBAs	28
3.2 FCC and Regulatory Notices	30
3.2.1 FCC Supplier's Declarations of Confirmation (LPe36000-Series and LPe35000-Series HBAs Only)	30
3.2.1.1 LPe36000 HBAs, LPe36002 HBAs, LPe35000 HBAs, and LPe35002 HBAs	30
3.2.1.2 LPe35004 HBAs	31
3.2.2 Regulatory Notices	32
3.2.2.1 Notice for North America (FCC and ICES)	32
3.2.2.2 Notice for Japan and Translations (VCCI)	32
3.2.2.3 Notice for Taiwan and Translations (BSMI)	32
3.2.2.4 Notice for South Korea and Translations (MSIP)	33
3.2.3 Laser Safety Notice	33
3.3 Declarations of Conformity	34
3.3.1 LPe36000 HBAs, LPe36002 HBAs, LPe35000 HBAs, and LPe35002 HBAs	34
3.3.2 LPe35004 HBAs	36
3.3.3 LPe31000 HBAs, LPe31002 HBAs, LPe32000 HBAs, and LPe32002 HBAs	38
3.3.4 LPe31004 HBAs	40
3.3.5 LPe16000B HBAs and LPe16002B HBAs	42
3.3.6 LPe16004 HBAs	44
3.3.7 LPe15004 HBAs	46
3.3.8 LPe12002 HBAs, LPe12000 HBAs, and LPe1250 HBAs	47
3.3.9 LPe12004 HBAs	48
3.4 Taiwan RoHS Notices	49
3.4.1 LPe36000 HBAs, LPe36002 HBAs, LPe35000 HBAs, and LPe35002 HBAs	49
3.4.2 LPe35004 HBAs	50
3.4.3 LPe31000-Series HBAs and LPe32000-Series HBAs	51
3.4.4 LPe16000B-Series HBAs, LPe16004 HBAs, and LPe15004 HBAs	53
3.4.5 LPe12000-Series HBAs and LPe1250 HBAs	55

Chapter 1: Introduction

This document supports the following Emulex® HBAs:

- LPe36000-series HBAs
- LPe35000-series HBAs
- LPe32000-series HBAs
- LPe31000-series HBAs
- LPe16000-series HBAs
- LPe15004 HBAs
- LPe12000-series HBAs
- LPe1250 HBAs

NOTE: Illustrations in this document are examples only. The actual hardware can vary.

1.1 LPe36000-Series HBAs and LPe35000-Series HBAs

This section describes the following FC-to-PCIe Emulex LPe36000-series HBAs and LPe35000-series HBAs:

- LPe36000-series HBAs (64Gb/s, 32Gb/s, or 16Gb/s):
 - LPe36000 (one port)
 - LPe36002 (two ports)
- LPe35000-series HBAs (32Gb/s, 16Gb/s or 8Gb/s):
 - LPe35000 (one port)
 - LPe35002 (two ports)
 - LPe35004 (four ports)

1.1.1 Major Features

LPe36000-series HBAs and LPe35000-series HBAs have the following major features:

- Trunking (also called FC port aggregation) with Brocade® switches, which provides the ability to trunk up to four physical ports per HBA to present a single port with aggregate performance (up to 128 Gb)
- Autonegotiation between 32Gb/s, 16Gb/s, or 8Gb/s (LPe35000-series HBAs) or between 64Gb/s, 32Gb/s, or 16Gb/s (LPe36000-series HBAs) FC link speeds using factory-shipped optics
- Industry seventh-generation FC controller core technology
- ECC protection of high-density RAM (single-bit correction, double-bit detection)
- SFP+ interface supporting optics with LC connections and digital diagnostics capability (only Emulex-approved 64Gb/s [LPe36000-series HBAs] and 32Gb/s SFP+ optical modules [LPe36000-series HBAs and LPe 35000-series HBAs] are supported)
- Host interface support provided through Emulex standard drivers
- Parts and construction compliant to the European Union Directive of RoHS
- Fully featured FC ports compliant to various INCITS FC standards
- Speed changeable from 32Gb/s to 64Gb/s or from 64Gb/s to 32Gb/s through hardware on some adapters; see [Section 2.6, Special Features of LPe36000-Series HBAs, LPe35000-Series HBAs, LPe32000-Series HBAs, and LPe31000-Series HBAs](#)

LPe36000 HBAs and LPe36002 HBAs have the following major features:

- Multifunction PCIe Gen4 interface controller that is compliant to the PCI Express Base Specification Rev 4.0 (backwards compatible with Rev 3.0) and the PCI Express CEM Specification Rev 4.0 (backwards compatible with Rev 3.0)
- Packet transfers at 2.5 GT/s, 5 GT/s, 8 GT/s, and 16 GT/s on the PCIe link (autonegotiated with the system), x1 to x8 lane
- An x8 bus slot physical PCIe connector

LPe35000 HBAs and LPe35002 HBAs have the following major features:

- Multifunction PCIe Gen4 interface controller that is compliant to the PCI Express Base Specification Rev 4.0 (backwards compatible with Rev 3.0) and the PCI Express CEM Specification Rev 4.0 (backwards compatible with Rev 3.0)
- Packet transfers at 2.5 GT/s, 5 GT/s, 8 GT/s, and 16 GT/s on the PCIe link (autonegotiated with the system), x1 to x8 lane
- An x8 bus slot physical PCIe connector

LPe35004 HBAs have the following major features:

- Multifunction PCIe Gen3 interface controller that is compliant to the PCI Express Base Specification Rev 3.0 and the PCI Express CEM Specification Rev 3.0
- Packet transfers at 2.5 GT/s, 5 GT/s, 8 GT/s on the PCIe link (autonegotiated with the system), x1 to x16 lane
- An x16 bus slot physical PCIe connector

1.1.2 Compatibility

Table 1: Software and Hardware Environments

Software environments	Refer to the Broadcom® website at www.broadcom.com for compatible operating systems.
Hardware environments	<p>LPe36000 HBAs and LPe36002 HBAs: PCIe 4.0 and PCIe 3.0 support x8, x4, and x1 bus slots.</p> <p>LPe35000 HBAs and LPe35002 HBAs: PCIe 4.0 and PCIe 3.0 support x8, x4, x2, and x1 bus slots.</p> <p>LPe35004 HBAs: PCIe 3.0 supports x16, x8, x4, x2, and x1 bus slots.</p> <p>NOTE: LPe36000 HBAs, LPe36002 HBAs, LPe35000 HBAs, and LPe35002 HBAs are backwards compatible with PCIe Rev. 1.0a, 1.1, 2.0, and 3.0-compliant computers.</p> <p>NOTE: LPe35004 HBAs are backwards compatible with PCIe Rev. 1.0a, 1.1, and 2.0-compliant computers.</p>

1.1.3 Prerequisites

For LPe36000 HBAs, LPe36002 HBAs, LPe35000 HBAs, and LPe35002 HBAs, use PCIe Gen4-compliant or Gen3-compliant computers that have x8 or x16 lanes at up to 8 GT/s per lane.

For LPe35004 HBAs, use PCIe Gen3-compliant computers that have x16 lanes at up to 8 GT/s per lane.

1.2 LPe32000-Series HBAs and LPe31000-Series HBAs

This section describes the following FC-to-PCIe Emulex LPe32000-series HBAs and LPe31000-series HBAs:

- LPe32000-series HBAs (32Gb/s, 16Gb/s, or 8Gb/s):
 - LPe32000 (one port)
 - LPe32002 (two ports)

- LPe31000-series HBAs (16Gb/s or 8Gb/s):
 - LPe31000 (one port)
 - LPe31002 (two ports)
 - LPe31004 (four ports)

NOTE: It is possible to change the speed of some HBAs from 16Gb/s to 32Gb/s, or from 32Gb/s to 16Gb/s, through hardware. Also, LPe32000-series HBAs and LPe31000-series HBAs include a Secure Firmware feature. See [Section 2.6, Special Features of LPe36000-Series HBAs, LPe35000-Series HBAs, LPe32000-Series HBAs, and LPe31000-Series HBAs](#) for more information.

1.2.1 Major Features

LPe32000-series HBAs and LPe31000-series HBAs have the following major features:

- Support for FEC using IEEE 802.3-2008 and later (applies to 16Gb/s and faster units)
- Autonegotiation between 4Gb/s, 8Gb/s, or 16Gb/s (LPe31000-series HBAs) or between 8Gb/s, 16Gb/s, or 32Gb/s (LPe32000-series HBAs) FC link speeds using factory-shipped optics
- Multifunction PCIe Gen3 interface controller that is compliant to the PCI Express Base Specification Rev 3.0 and PCI Express CEM Specification Rev 3.0
- Packet transfers at 2.5 GT/s, 5 GT/s, and 8 GT/s on the PCIe link (autonegotiated with the system), x1 to x8 lane
- An x8 bus slot physical PCIe connector
- Industry sixth-generation FC controller core technology
- ECC protection of high-density RAM (single-bit correction, double-bit detection)
- SFP+ interface supporting optics with LC connections and digital diagnostics capability
- Host interface support provided through Emulex standard drivers
- Parts and construction compliant to the European Union Directive of RoHS
- Fully featured FC ports compliant to various ANSI FC standards

1.2.2 Compatibility

Table 2: Software and Hardware Environments

Software environments	Refer to the Broadcom website at www.broadcom.com for compatible operating systems.
Hardware environments	<p>LPe32000-series HBAs: PCIe 3.0 supports x8, x4, and x1 bus slots.</p> <p>LPe31000-series HBAs: PCIe 3.0 supports x8, x4, x2, and x1 bus slots.</p> <p>NOTE: HBAs are compatible with PCIe 3.0 and CEM 3.0-compliant computers and are backwards compatible with 1.0a, 1.1, and 2.0-compliant computers.</p>

1.2.3 Prerequisites

Use PCIe Gen3-compliant computers that have x8 or x16 lanes at up to 8 GT/s per lane.

1.3 LPe16000-Series HBAs and LPe15004 HBAs

This section describes the following FC-to-PCIe Emulex LPe16000-series HBAs and LPe15004 HBAs:

- LPe16000-series HBAs (16Gb/s):
 - LPe16000B (one port)
 - LPe16002B (two ports)
 - LPe16004 (four ports)
- LPe15004 HBAs (8Gb/s)

1.3.1 Major Features

LPe16000-series HBAs and LPe15004 HBAs have the following major features:

- Autonegotiation between 4Gb/s and 8Gb/s (LPe15004 HBAs), or 4Gb/s, 8Gb/s, and 16Gb/s (all other HBAs) FC link speeds
- Multifunction PCIe Gen3 interface controller that is compliant to the PCI Express Base Specification Rev 3.0 and PCI Express CEM Specification Rev 3.0
- Packet transfers at 2.5, 5 GT/s, and 8 GT/s on the PCIe link (autonegotiated with the system)
- An x8 bus slot physical PCIe connector
- Industry fifth-generation FC controller core technology
- ECC protection of high density RAM (single-bit correction, double-bit detection)
- SFP+ interface supporting optics with LC connections and digital diagnostics capability
- Host interface support provided through Emulex standard drivers
- Parts and construction compliant to the European Union Directive of RoHS
- Fully featured FC ports compliant to various ANSI FC standards

1.3.2 Compatibility

Table 3: Software and Hardware Environments

Software environments	Refer to the Broadcom website at www.broadcom.com for compatible operating systems.
Hardware environments	<p>LPe15004 HBAs: PCIe 3.0 supports x8, x4, x2, and x1 bus slots.</p> <p>All other HBAs: PCIe 3.0 supports x8, x4, and x1 bus slots.</p> <p>NOTE: HBAs are compatible with PCIe 3.0 and CEM 3.0-compliant computers and are backwards compatible with 1.0a, 1.1, and 2.0-compliant computers.</p>

1.3.3 Prerequisites

Use PCIe Gen3-compliant computers that have x8 or x16 lanes at up to 8 GT/s per lane.

1.4 LPe12000-Series HBAs

This section describes the following 8Gb/s, FC-to-PCIe Emulex LPe12000-series HBAs:

- LPe12000-M8 (one port, multimode optical interface with short-wave lasers)
- LPe12002-M8 (two ports, multimode optical interface with short-wave lasers)
- LPe12002-X8 (two ports, single-mode optical interface with long-wave lasers)
- LPe12004 (four ports, multimode optical interface with short-wave lasers)

1.4.1 Major Features

LPe12000-series HBAs have the following major features:

- Revolutionary design with integrated ARM-1156 cores, integrated SerDes, integrated SRAM, and external DDR SRAM memory structure
- Built-in temperature sensor
- Autonegotiation between 2Gb/s, 4Gb/s, or 8Gb/s FC link speeds
- Multifunction native PCIe core that is compliant to the PCI Express Base Specification Rev. 2.0 and PCI Express CEM Specification Rev. 2.0
- Packet transfers up to 5 GT/s on the PCIe link
- An x8 bus slot physical PCIe connector
- Host interface support provided through Emulex standard drivers
- Parts and construction compliant to the European Union Directive of RoHS
- Fully featured FC ports compliant to various ANSI FC standards

1.4.2 Compatibility

Table 4: Software and Hardware Environments

Software environments	Refer to the Broadcom website at www.broadcom.com for compatible operating systems.
Hardware environments	HBAs are compatible with PCIe 2.0 and CEM 2.0-compliant computers, and are backwards compatible with 1.0a and 1.1-compliant computers.

1.4.3 Prerequisites

Use PCIe Gen2-compliant computers that have an x4 or x8 lane transfer link interface.

1.5 LPe1250 HBAs

This section describes the Emulex LPe1250 HBA, a single-channel, 8Gb/s, FC-to-PCIe HBA.

1.5.1 Major Features

The LPe1250 HBA has the following major features:

- Revolutionary design with an integrated ARM-1156 core, integrated SerDes, and integrated SRAM
- Built-in temperature sensor
- Autonegotiation between 2Gb/s, 4Gb/s, or 8Gb/s FC link speeds
- Multifunction native PCIe core that is compliant to the PCIe Base Specification Rev. 2.0 and PCI Express CEM Specification Rev. 2.0
- Packet transfers up to 5 GT/s on the PCIe link
- An x8 physical PCIe connector
- Host interface support provided through Emulex standard drivers
- Parts and construction compliant to the European Union Directive of RoHS
- Fully featured FC port compliant to various ANSI FC standards

1.5.2 Compatibility

Table 5: Software and Hardware Environments

Software environments	Refer to the Broadcom website at www.broadcom.com for compatible operating systems.
Hardware environments	HBAs are compatible with PCIe 2.0 and CEM 2.0-compliant computers, and are backwards compatible with 1.0a and 1.1-compliant computers.

1.5.3 Prerequisites

Use PCIe Gen2-compliant computers that have an x4 or x8 lane transfer link interface.

1.6 HBA Identification

Each HBA ships with several numbers clearly marked on the board. Record these numbers before installation.

- **Serial number** – Assigned by Emulex. Use this number when communicating with Broadcom Technical Support.
- **IEEE address** – An IEEE unique 48-bit identifier used for system configuration.
- **WWN** – Derived from the IEEE address; the FC industry uses the WWN for FC connectivity.

NOTE: IEEE addresses and WWNs are assigned in sequential order. For example, if an HBA has four ports, it has four IEEE addresses and four WWNs, one for each port. The second, third, and fourth IEEE addresses and WWNs are the next successive numbers after the first.

1.7 Abbreviations

Table 6: Acronyms and Abbreviations

Acronym/Abbreviation	Description
CEM	Card electromechanical
FEC	forward error correction
Gb/s	gigabits per second
GT/s	giga-transfers per second
ID	identification
INCITS	International Committee for Information Technology Standards
mVpp	millivolt peak-to-peak
RMN	regulatory model number

Chapter 2: Installation

The standard HBAs can be connected to fiber-optic cables.

If you do not need to change the HBA's bracket, skip to [Section 2.2, Installing the HBA](#). Otherwise, continue to [Section 2.1, Preparing the HBA for Installation](#).

2.1 Preparing the HBA for Installation

Most HBAs ship from the factory with a standard full-height PCIe mounting bracket installed, which you can remove and replace with a low-profile bracket. Other HBAs ship from the factory with a low-profile PCIe mounting bracket installed, which you can replace with a full-height bracket.

Some HBAs have removable optical transceivers, whereas others have fixed optical transceivers. If you are replacing the mounting bracket, and the HBA has removable optical transceivers, you must first remove all installed optical transceivers from the housing (cage).

See the following table to determine the type of optical transceivers and the type of mounting bracket that are factory-installed on each HBA model.

Table 7: Optical Transceiver and Mounting Bracket Types

Series	HBA	Optical Transceiver Type	Factory-Installed Mounting Bracket Type
LPe36000	LPe36000	Removable	Full height
	LPe36002	Removable	Full height
LPe35000	LPe35000	Removable	Full height
	LPe35002	Removable	Full height
	LPe35004	Removable	Full height
LPe32000	LPe32000	Removable	Full height
	LPe32002	Removable	Full height
LPe31000	LPe31000	Removable	Full height
	LPe31002	Removable	Full height
	LPe31004	Fixed	Full height
LPe16000	LPe16000B	Removable	Full height
	LPe16002B	Removable	Full height
	LPe16004	Removable	Full height
	LPe15004	Fixed	Low profile
LPe12000	LPe12000	Removable	Full height
	LPe12002	Removable	Full height
	LPe12004	Removable	Full height
—	LPe1250	Removable	Full height

If the HBA does not contain removable optical transceivers, skip to [Step 3](#). Otherwise, follow these steps:

1. Remove the transceivers from their cage assemblies.

The HBA uses various types of optical transceivers. [Figure 1](#) shows an example of one type with the bail (handle) extended.

Figure 1: Typical Optical Transceiver

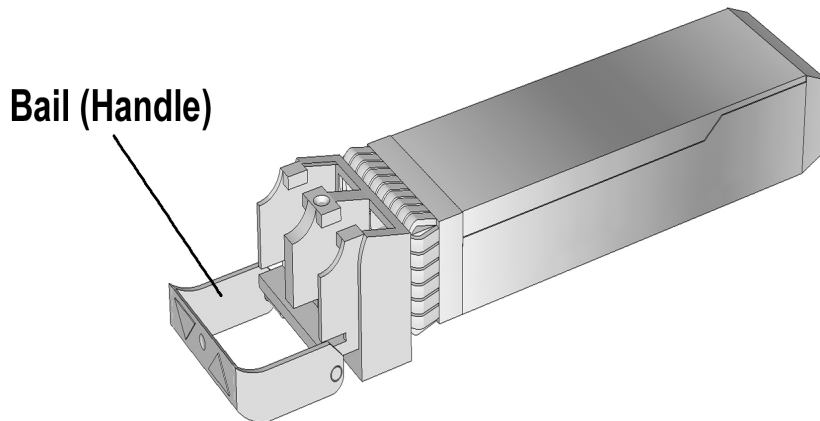

CAUTION! This is a delicate operation. Take care not to damage the optical transceiver.

To remove a transceiver, pull the bail (handle) out and down to release the latch, and gently pull out the transceiver. Do not force it. After the latch is released, the transceiver slides out easily.

[Figure 2](#) shows a transceiver with the latch released (bail extended) and another transceiver latched in place.

Figure 2: Releasing the Latch on an Optical Transceiver

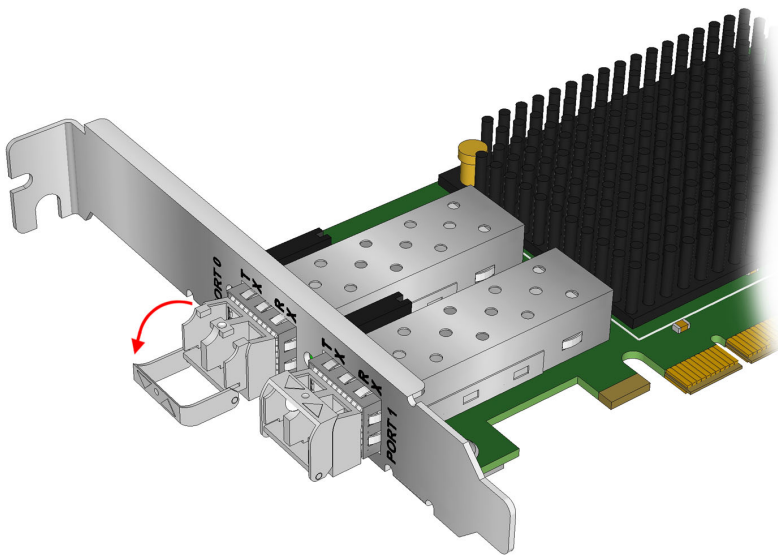

[Figure 3](#) shows an extracted transceiver and another transceiver latched in place.

Figure 3: Removing an Optical Transceiver

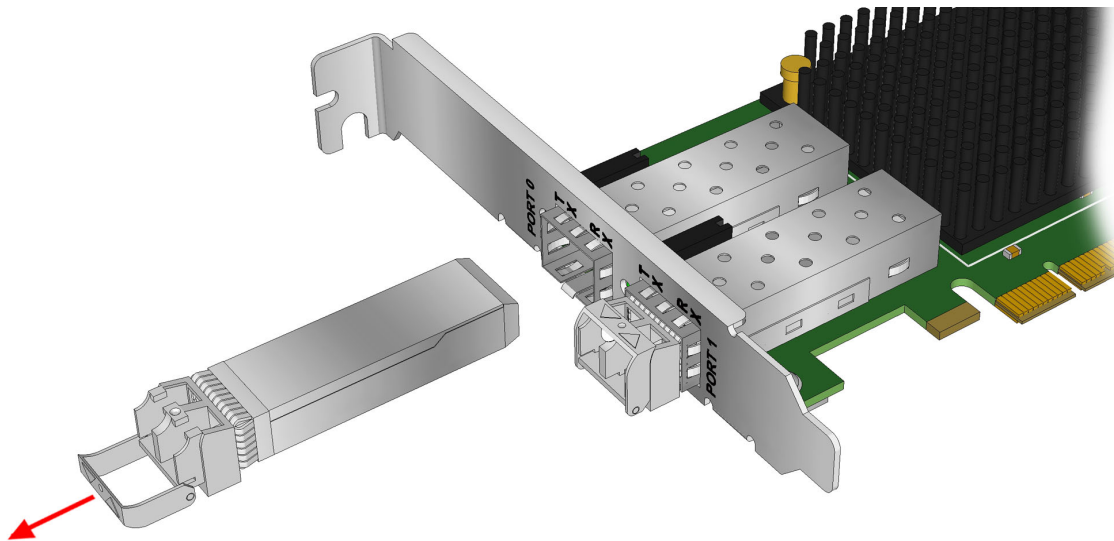

2. Observing ESD precautions, store the transceiver in an ESD-safe place.
3. Remove the mounting bracket screws and washers from the top of the HBA. [Figure 4](#) shows the screws that are removed from the mounting bracket.

Figure 4: Removing the Mounting Bracket

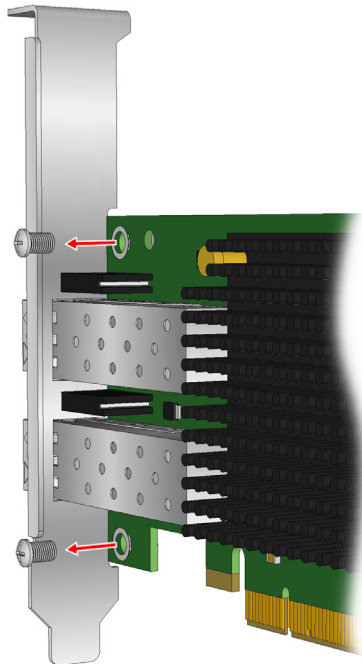

4. Remove the mounting bracket, and store it for future use.
5. Align the new mounting bracket tabs with the holes in the HBA.

CAUTION! Be careful not to push the mounting bracket past the grounding tabs on the transceiver housing. Make sure the LEDs are properly aligned with the holes in the mounting bracket.

6. Reinstall the screws and washers that attach the HBA to the mounting bracket. If you did not remove optical transceivers, skip to [Section 2.2, Installing the HBA](#).
7. Reinstall the transceiver by sliding it into the housing. When the latch engages, it clicks.
8. Push the bail back into place.

2.2 Installing the HBA

For LPe12000-series HBAs, if you need to change the PCI device ID jumper setting, follow the instructions in [Section 2.5, Changing the PCI Device ID Jumper Setting](#), and then continue with this section.

To install the HBA, follow these steps:

1. Turn off the computer if hot-plug installation is not supported on the computer.
Refer to your computer documentation to see if the computer supports hot-plug or hot-swap of PCIe HBA cards.
2. Remove the computer case.
3. Remove the blank panel from an empty PCIe bus slot. All Emulex HBAs can use x16 PCIe bus slots. All Emulex HBAs except LPe35004 HBAs can use x8 PCIe bus slots.
4. Insert the HBA into the empty slot. Press firmly until the HBA is seated.

NOTE: Make sure that the HBA is in an appropriate PCIe slot that does not interfere with other components or with the case to prevent damage to the HBA.

5. Secure the HBA mounting bracket to the case with a panel screw or clip.
6. Replace the computer case and tighten the case screws.

The HBA is now installed in the server and is ready for an FC device.

2.3 Attaching Media

NOTE: The HBA does not allow normal data transmission on an optical link unless it is connected to another similar or compatible laser product (that is, multimode to multimode, or single-mode to single-mode).

The HBA does not automatically downgrade to the required FC speed based on the cable length. You must downgrade the speed with the appropriate utility, or link errors might occur.

Use a multimode fiber-optic cable with short-wave lasers, or use a single-mode fiber-optic cable with long-wave lasers. The cable must adhere to the specifications in the following tables. See the table that includes your HBA.

NOTE: The following HBAs cannot use single-mode fiber-optic cable with long-wave fibers:

- LPe16000B
- LPe16002B
- LPe16004
- LPe15004
- LPe12000-M8
- LPe12002-M8
- LPe1250

Table 8: Media Specifications (LPe36000-Series HBAs and LPe35000-Series HBAs)

Fiber-Optic Cable	Maximum Length	Minimum Length	Connector
OM4 and OM5 – Multimode 50/125 micrometer fiber (4700 MHz × km bandwidth cable)	8GFC: 0.5m to 190m 16GFC: 0.5m to 125m 32GFC: 0.5m to 100m 64GFC: 0.5m to 100m	0.5 meters	LC
OM3 – Multimode 50/125 micrometer fiber (2000 MHz × km bandwidth cable)	8GFC: 0.5m to 150m 16GFC: 0.5m to 100m 32GFC: 0.5m to 70m 64GFC: 0.5m to 70m	0.5 meters	LC
OM2 – Multimode 50/125 micrometer fiber (500 MHz × km bandwidth cable)	8GFC: 0.5m to 50m 16GFC: 0.5m to 35m 32GFC: 0.5m to 20m 64GFC: N/A	0.5 meters	LC
OM1 – Multimode 62.5/125 micrometer fiber (200 MHz × km bandwidth cable)	8GFC: 0.5m to 21m 16GFC: 0.5m to 15m 32GFC: N/A 64GFC: N/A	0.5 meters	LC
OS2 – Single-mode 9/125 micrometer fiber (0.4 dB/km attenuation, type B1.3)	8GFC: 0.5m to 10 km 16GFC: 0.5m to 10 km 32GFC: 0.5m to 10 km 64GFC: 0.5m to 10 km	0.5 meters	LC
OS1 – Single-mode 9/125 micrometer fiber (1.0 dB/km attenuation, type B1.1)	8GFC: 0.5m to 10 km 16GFC: 0.5m to 10 km 32GFC: 0.5m to 10 km 64GFC: N/A	0.5 meters	LC

Table 9: Media Specifications (LPe32000-Series HBAs and LPe31000-Series HBAs)

Fiber-Optic Cable	Maximum Length	Minimum Length	Connector
OM4 – Multimode 50/125 micrometer fiber (4700 MHz × km bandwidth cable)	4GFC: 0.5m to 400m 8GFC: 0.5m to 190m 16GFC: 0.5m to 125m 32GFC: 0.5m to 100m	0.5 meters	LC
OM3 – Multimode 50/125 micrometer fiber (2000 MHz × km bandwidth cable)	4GFC: 0.5m to 380m 8GFC: 0.5m to 150m 16GFC: 0.5m to 100m 32GFC: 0.5m to 70m	0.5 meters	LC
OM2 – Multimode 50/125 micrometer fiber (500 MHz × km bandwidth cable)	4GFC: 0.5m to 150m 8GFC: 0.5m to 50m 16GFC: 0.5m to 35m 32GFC: 0.5m to 20m	0.5 meters	LC
OM1 – Multimode 62.5/125 micrometer fiber (200 MHz × km bandwidth cable)	4GFC: 0.5m to 70m 8GFC: 0.5m to 21m 16GFC: 0.5m to 15m 32GFC: N/A	0.5 meters	LC

Table 9: Media Specifications (LPe32000-Series HBAs and LPe31000-Series HBAs) (Continued)

Fiber-Optic Cable	Maximum Length	Minimum Length	Connector
OS2 – Single-mode 9/125 micrometer fiber (0.4 dB/km attenuation, type B1.3)	4GFC: 0.5m to 10km 8GFC: 0.5m to 10km 16GFC: 0.5m to 10 km 32GFC: 0.5m to 10 km	0.5 meters	LC
OS1 – Single-mode 9/125 micrometer fiber (1.0 dB/km attenuation, type B1.1)	4GFC: 0.5m to 10 km 8GFC: 0.5m to 10 km 16GFC: 0.5m to 10 km 32GFC: 0.5m to 10 km	0.5 meters	LC

Table 10: Media Specifications (LPe16000-Series HBAs and LPe15004 HBAs)

Fiber-Optic Cable	Maximum Length	Minimum Length	Connector
OM4 - Multimode 50/125 micrometer fiber (4700 MHz × km bandwidth cable)	4GFC: 0.5m to 400m 8GFC: 0.5m to 190m 16GFC: 0.5m to 125m	0.5 meters	LC
OM3 - Multimode 50/125 micron fiber (2000 MHz × km bandwidth cable)	4GFC: 0.5m to 380m 8GFC: 0.5m to 150m 16GFC: 0.5m to 100m	0.5 meters	LC
OM2 - Multimode 50/125 micron fiber (500 MHz × km bandwidth cable)	4GFC: 0.5m to 150m 8GFC: 0.5m to 50m 16GFC: 0.5m to 35m	0.5 meters	LC
OM1 - Multimode 62.5/125 micron fiber (200 MHz × km bandwidth cable)	4GFC: 0.5m to 70m 8GFC: 0.5m to 21m 16GFC: 0.5m to 15m	0.5 meters	LC

Table 11: Media Specifications (LPe12000-Series HBAs)

Fiber-Optic Cable	Maximum Length	Minimum Length	Connector
OM3 – Multimode 50/125 micrometer fiber (2000 MHz × km bandwidth cable) LPe12000-M8, LPe12002-M8, and LPe12004 HBAs	2.125Gb/s: 0.5m to 500m 4.25Gb/s: 0.5m to 380m 8.5Gb/s 0.5m to 150m	0.5 meters	LC
OM2 – Multimode 50/125 micrometer fiber (500 MHz × km bandwidth cable) LPe12000-M8, LPe12002-M8, and LPe12004 HBAs	2.125Gb/s: 0.5m to 300m 4.25Gb/s: 0.5m to 150m 8.5Gb/s 0.5m to 50m	0.5 meters	LC
OM1 – Multimode 62.5/125 micrometer fiber (200 MHz × km bandwidth cable) LPe12000-M8, LPe12002-M8, and LPe12004 HBAs	2.125Gb/s: 0.5m to 150m 4.25Gb/s: 0.5m to 70m 8.5Gb/s 0.5m to 21m	0.5 meters	LC
OS1/OS2 – Single-mode 9 micrometer fiber LPe12002-X8 HBA only	2.125Gb/s: 0.5m to 10 km 4.25Gb/s: 0.5m to 10 km 8.5Gb/s 0.5m to 10 km	0.5 meters	LC

Table 12: Media Specifications (LPe1250 HBAs)

Fiber-Optic Cable	Maximum Length	Minimum Length	Connector
OM3 – Multimode 50/125 micrometer fiber (2000 MHz × km bandwidth cable)	2.125Gb/s: 0.5m to 500m 4.25Gb/s: 0.5m to 380m 8.5Gb/s 0.5m to 150m	0.5 meters	LC
OM2 – Multimode 50/125 micrometer fiber (500 MHz × km bandwidth cable)	2.125Gb/s: 0.5m to 300m 4.25Gb/s: 0.5m to 150m 8.5Gb/s 0.5m to 50m	0.5 meters	LC
OM1 – Multimode 62.5/125 micrometer fiber (200 MHz × km bandwidth cable)	2.125Gb/s: 0.5m to 150m 4.25Gb/s: 0.5m to 70m 8.5Gb/s 0.5m to 21m	0.5 meters	LC

To attach media to the HBA, follow these steps:

1. Ensure that the cages have optical transceivers installed in them. If necessary, insert an optical transceiver into each cage.

The following table provides a list of approved optics.

Table 13: Approved Optics

HBA	Model Number	Description	Quantity in Pack	Interface	Comments
LPe36000-series LPe35000-series	LP64-LW-OPT-1	64GFC optic (long-wave laser)	1	SFP+	For LPe36000-series and LPe35000-series HBAs, can be used as an onsite spare. Allows upgrade from LPe35000-series to LPe36000-series.
LPe36000-series LPe35000-series	LP64-LW-OPT-2	64GFC optic (long-wave laser)	2	SFP+	For LPe36000-series and LPe35000-series HBAs, can be used as an onsite spare. Allows upgrade from LPe35000-series to LPe36000-series.
LPe35000-series LPe32000-series LPe31000-series	LP32-LW-OPT-1	32GFC optic (long-wave laser)	1	SFP+	For LPe35000-series and LPe32000-series HBAs, can be used as an onsite spare. Allows upgrade from LPe31000-series to LPe32000-series.
LPe35000-series LPe32000-series LPe31000-series	LP32-LW-OPT-2	32GFC optic (long-wave laser)	2	SFP+	For LPe35000-series and LPe32000-series HBAs, can be used as an onsite spare. Allows upgrade from LPe31000-series to LPe32000-series.

Table 13: Approved Optics (Continued)

HBA	Model Number	Description	Quantity in Pack	Interface	Comments
LPe32000-series LPe31000-series	LP32-SW-OPT-1	32GFC optic (short-wave laser)	1	SFP+	For LPe32000-series HBAs, can be used as an onsite spare. Allows upgrade from LPe31000-series to LPe32000-series.
LPe32000-series LPe31000-series	LP32-SW-OPT-2	32GFC optic (short-wave laser)	2	SFP+	For LPe32000-series HBAs, can be used as an onsite spare. NOTE: Allows upgrade from LPe31000-series to LPe32000-series.
LPe16000-series	LPe16100-OPT	16GFC optic (short-wave laser)	1	SFP+	For LPe16000-series HBAs, can be used as an onsite spare. NOTE: LPe15004 HBAs do not support replaceable optics.
LPe16000-series	LPe16100-OPTx2	16GFC optic (short-wave laser)	2	SFP+	For LPe16000-series HBAs, can be used as an onsite spare. NOTE: LPe15004 HBAs do not support replaceable optics.
LPe12000-series (except LPe12002-X8)	LPe12100-OPT	8GFC optic (short-wave laser)	1	SFP+	For all HBAs except LPe12002-X8, can be used as an onsite spare.

NOTE: Only Emulex accessories are warranted and fully supported by Broadcom Technical Support.

Figure 5: Installing an Optical Transceiver

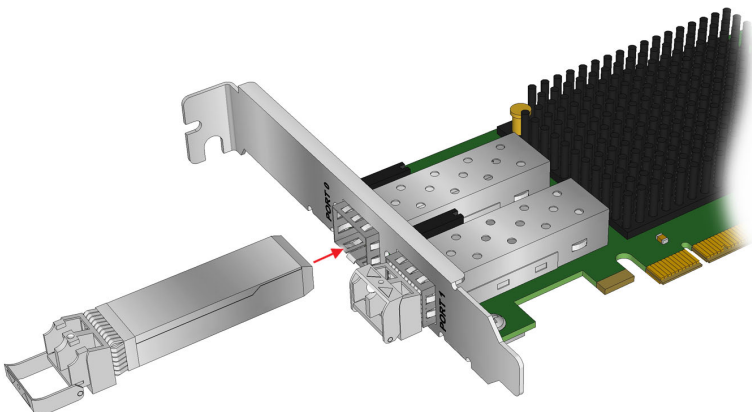

2. Insert an appropriate optical cable into the LC connectors on the HBA.

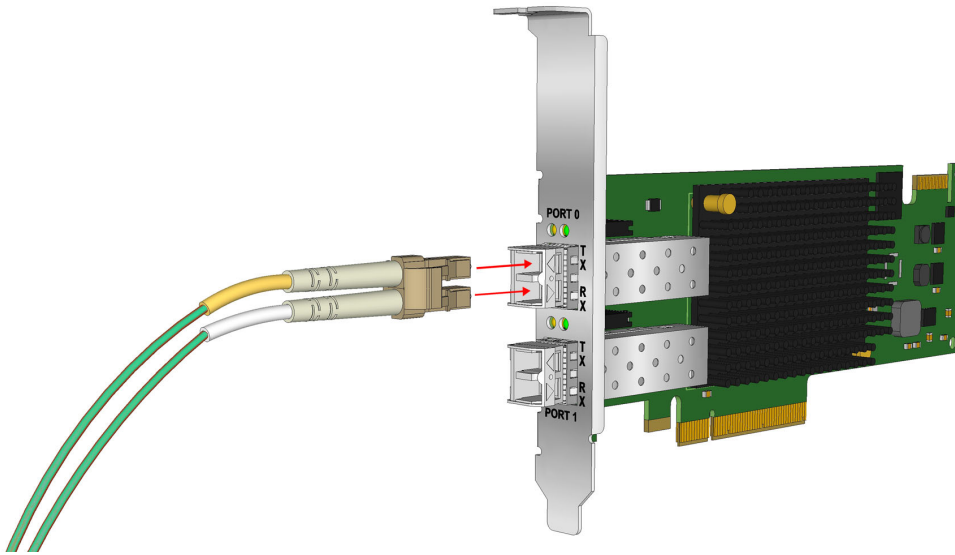
Figure 6: Connecting a Fiber-Optic Cable

3. Connect the other end to the FC device.

You are ready to apply power to the computer.

2.4 Applying Power

To apply power, follow these steps:

1. Verify that the HBA is securely installed in the computer.
2. Verify that the correct media is attached.
3. Plug in the computer, and turn it on.
4. Watch the LEDs for POST results.

2.4.1 Viewing the LEDs

You can view the yellow and green LEDs through openings in the HBA's mounting bracket. The yellow LED indicates port activity or link speed, and the green LED indicates firmware operation. Each port has a corresponding set of yellow and green LEDs.

Figure 7: Optical HBA LED Indicators

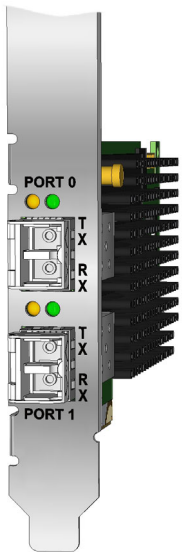

2.4.2 POST Conditions and Results

POST is the default mode of self-test for Emulex HBAs. No jumpers or connectors are necessary for this test to run. This test performs a quick confidence level check of the HBA when it is powered on, and before it runs the operational software.

At a minimum, the following tests are performed by POST:

- Flash boot image checksum test
- Internal ASIC RAM tests for proper ECC parity operation
- Loopback test

The following table summarizes POST conditions and results.

NOTE: For the link rate conditions, a 1s pause occurs when the yellow LED is off between each group of fast blinks (2, 3, 4, or 5, depending on the HBA). Observe the LED sequence for several seconds to be sure you have correctly identified the pattern.

Table 14: POST Conditions and Results

HBA	Yellow LED	Green LED	State
All	Off	Off	No SFP module is installed or a boot failure occurred (dead board)
All	On	Off	POST failure (dead board)
All	Slow blink	Off	Boot failure after POST
All	Flashing	Off	POST processing is in progress
All	Off	On	Failure in the common code module
All	On	On	Failure in the common code module
LPe36000-series and LPe35000-series	3 fast blinks	On	Normal (link up at 8GFC) (LPe35000-series only)
	4 fast blinks	On	Normal (link up at 16GFC)
	5 fast blinks	On	Normal (link up at 32GFC)
	6 fast blinks	On	Normal (link up at 64GFC) (LPe36000-series only)
	Fast blink	Fast blink	Beaconing
LPe32000-series and LPe31000-series	2 fast blinks	On	Normal (link up at 2GFC) (LPe31000-series only)
	3 fast blinks	On	Normal (link up at 8GFC)
	4 fast blinks	On	Normal (link up at 16GFC)
	5 fast blinks	On	Normal (link up at 32GFC) (LPe32000-series only)
	Fast blink	Fast blink	Beaconing
LPe16000-series	1 fast blink	On	Normal (link up at 2GFC) (LPe15004 only)
	2 fast blinks	On	Normal (link up at 4GFC)
	3 fast blinks	On	Normal (link up at 8GFC)
	4 fast blinks	On	Normal (link up at 16GFC) (LPe1600x only)
	Fast blink	Fast blink	Beaconing
LPe12000-series and LPe1250	2 fast blinks	On	Normal (link up at 2GFC)
	3 fast blinks	On	Normal (link up at 4GFC)
	4 fast blinks	On	Normal (link up at 8GFC)
	Slow blink	Slow blink	Offline for download
All	Off	Slow blink	Normal (link down)

2.5 Changing the PCI Device ID Jumper Setting

NOTE: This section applies to LPe12000-series HBAs only.

The PCI device ID jumpers on LPe12000-series HBAs are used in custom applications. Do not change the jumper settings for a standard Emulex installation.

NOTE: Emulex HBAs contain electronic components that can be damaged by static electricity through an ESD event. To prevent ESD damage, maintain constant contact with any metal grounded surface. A grounding wrist strap is useful for this purpose. Handle the card carefully at all times, preferably by the edges. Avoid touching electronic components, and keep the card in the original packaging until you are ready for installation.

LPe12000 HBAs have one six-post jumper block that controls the HBA's device ID.

LPe12002 HBAs and LPe12002-X8 HBAs have two six-post jumper blocks that control the HBA's device ID for ports 0 and 1.

LPe12004 HBAs have four six-post jumper blocks that control the HBA's device ID for ports 0, 1, 2, and 3.

Select the ID by installing a jumper between posts 1 and 2, or 3 and 4, or 5 and 6, as described in [Table 15](#).

NOTE: Without a jumper, the HBA reports a device ID of 0x1AE5. Most software drivers require a PCI device ID of F100 to properly identify and control the HBA. Do not attempt to operate the HBA with the PCI device ID set to 0x1AE5 unless recommended by the driver installation instructions.

Table 15: Jumper Settings

PCI Identifier	P0_JX (Port 0)	P1_JX (Port 1)	P2_JX (Port 2)	P3_JX (Port 3)
F100	1-2	1-2	1-2	1-2
F101	3-4	3-4	3-4	3-4
1AE5	5-6	5-6	5-6	5-6

Figure 8: Jumper Settings

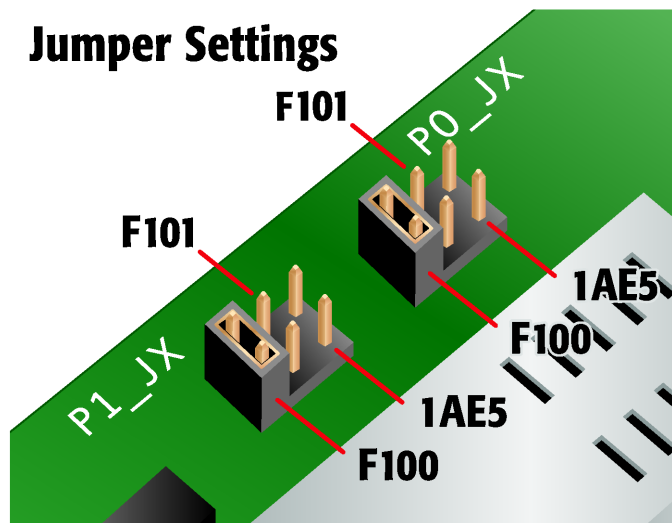

2.6 Special Features of LPe36000-Series HBAs, LPe35000-Series HBAs, LPe32000-Series HBAs, and LPe31000-Series HBAs

You can change the HBA speed on the following HBAs:

- LPe36000-series HBAs
- LPe35000-series HBAs
- LPe32000-series HBAs
- LPe31000-series HBAs

You can enable or disable the Secure Firmware feature on the following HBAs:

- LPe32000-series HBAs
- LPe31000-series HBAs

This section explains how to use these features.

2.6.1 Changing the Speed of the HBA

You can change the speed of the link on the following HBAs by replacing the optical transceivers:

- The transmission speed of the LPe35000-series and LPe36000-series adapters can be changed from 32GFC to 64GFC or from 64GFC to 32GFC.
- The transmission speed of the LPe31000-series and LPe32000-series HBAs can be changed from 16GFC to 32GFC or from 32GFC to 16GFC.

2.6.2 Setting the Secure Firmware Jumper

LPe31000-series HBAs and LPe32000-series HBAs have a jumper that enables or disables the Secure Firmware feature as required.

To update the firmware using a tool, such as the Emulex HBA Manager application (formerly the OneCommand™ Manager application), boot utilities, or Elxflash utilities, there is no need to remove the jumper. The Secure Firmware feature can remain enabled as long as the update is from one secure firmware version to another secure firmware version. To change the firmware version from a secure firmware version to an unsecured firmware version, you must first remove the jumper before updating the firmware.

Replace the jumper after the firmware update is complete.

The next two figures provide examples of common locations of the Secure Firmware jumper.

Figure 9: Secure Firmware Jumper Location J2 on LPe31000, LPe31002, LPe32000, and LPe32002 HBAs

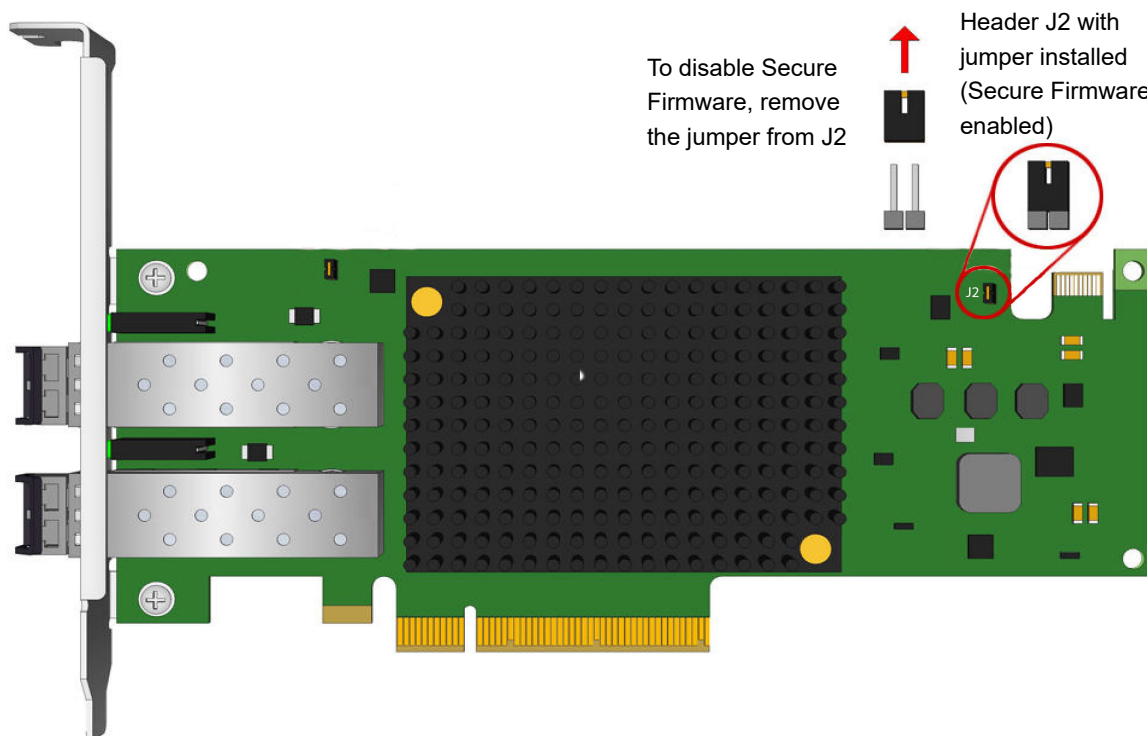
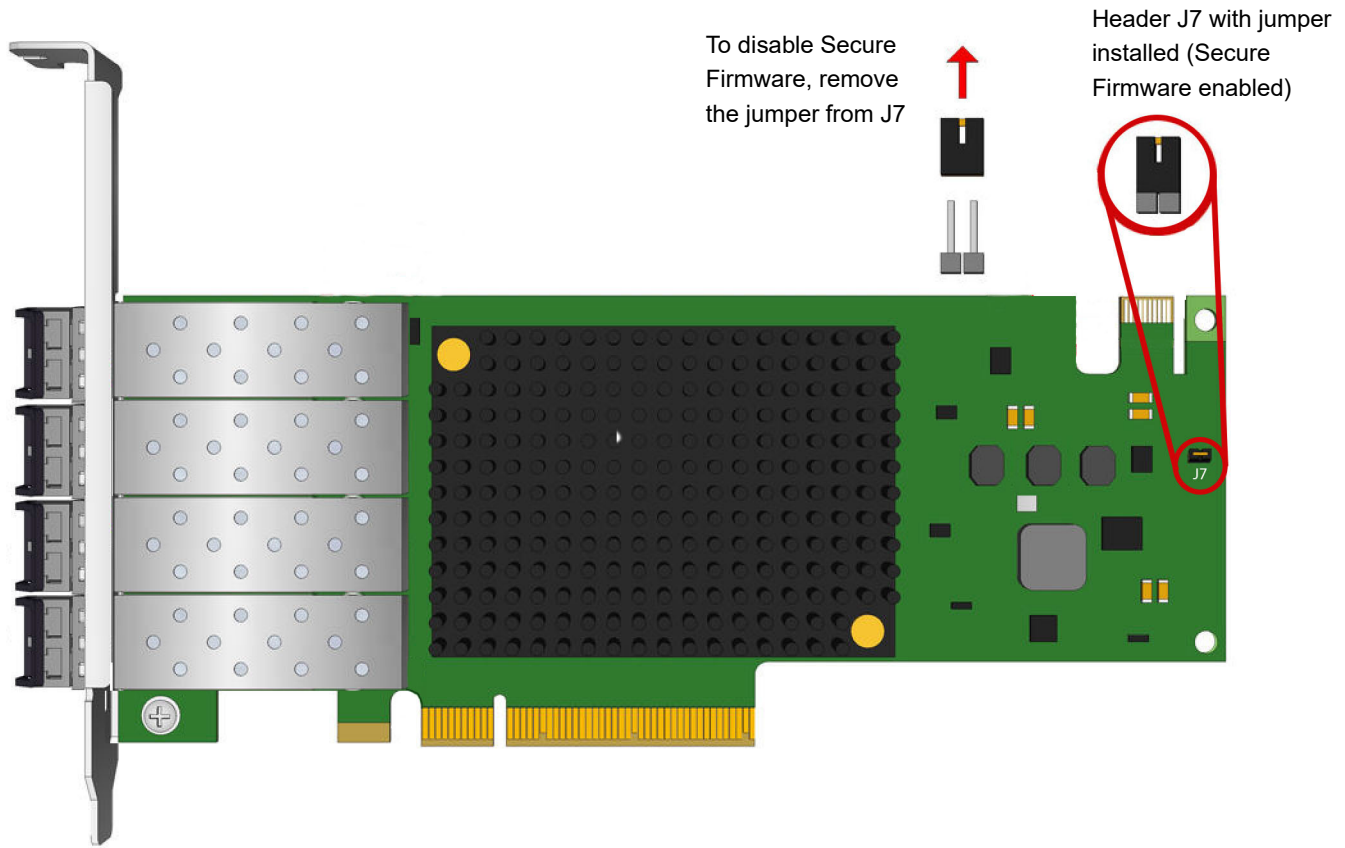

Figure 10: Secure Firmware Jumper Location J7 on LPe31004 HBAs



Chapter 3: References

3.1 Specifications

3.1.1 LPe36000-Series HBAs and LPe35000-Series HBAs

Table 16: LPe36000-Series HBAs and LPe35000-Series HBAs Specifications

Parameter	Range
Physical dimensions	LPe36000 HBAs and LPe36002 HBAs: low-profile form factor, 6.600 in. by 2.708 in. LPe35000 HBAs and LPe35002 HBAs: low-profile form factor, 6.600 in. by 2.708 in. LPe35004 HBAs: standard height, half-length form factor, 6.600 in. by 4.376 in.
Power requirements	Multimode optics (PCIe 3.0): <ul style="list-style-type: none"> ■ Single-channel LPe35000 HBAs: 8.8W (typical), 9.9W (maximum) ■ Dual-channel LPe35002 HBAs: 9.9W (typical), 11.0W (maximum) ■ Quad channel LPe35004 HBAs: 14.4W (typical), 15.9W (maximum) Single-mode optics (PCIe 3.0): <ul style="list-style-type: none"> ■ Single-channel LPe35000 HBAs: 8.9W (typical), 10.1W (maximum) ■ Dual-channel LPe35002 HBAs: 10.2W (typical), 11.3 (maximum) ■ Quad channel LPe35004 HBAs: 15.0W (typical), 16.4W (maximum) Multimode optics (PCIe 4.0): <ul style="list-style-type: none"> ■ Single channel LPe36000 adapter: 10.6W (typical), 11.9W (maximum) ■ Dual channel LPe36002 adapter: 12.4W (typical), 13.7W (maximum) ■ Single-channel LPe35000 HBAs: 9.6 (typical), 10.7 (maximum) ■ Dual-channel LPe35002 HBAs: 10.7 (typical), 11.8 (maximum) Single-mode optics (PCIe 4.0): <ul style="list-style-type: none"> ■ Single-channel LPe35000 HBAs: 9.7 (typical), 10.9 (maximum) ■ Dual-channel LPe35002 HBAs: 11.0 (typical), 12.1 (maximum)
Power susceptibility	The HBAs can operate within the following voltage ranges: PCIe 12V: 12V ± 8% Power supply noise susceptibility: 100 mVpp at frequencies 100 kHz or less
Airflow	LPe36000 HBAs and LPe36002 HBAs: 250 linear feet per minute (minimum) LPe35000 HBAs and LPe35002 HBAs: 200 linear feet per minute (minimum) LPe35004 HBAs: 275 linear feet per minute (minimum)
Temperature	0°C to 55°C (operating) –20°C to 85°C (storage) NOTE: Operating HBAs in higher temperature conditions might result in early failure.
Humidity	5% to 95% (noncondensing, 22°C wet bulb) for storage 10% to 90% (noncondensing, 22°C wet bulb) for operation

Table 16: LPe36000-Series HBAs and LPe35000-Series HBAs Specifications (Continued)

Parameter	Range
Agency approvals	<ul style="list-style-type: none"> ■ Class 1 Laser Product per DHHS 21CFR (J) and EN60825-1 when equipped with approved optical devices ■ UL recognized to 62368-1:2014 ■ cUR recognized to CAN/CSA 22.2, No. 62368-1-14 ■ FCC Rules, Part 15, Class A ■ Industry Canada, ICES-003, Class A ■ EU (CE Mark) ■ UKCA ■ EN55024:2010 ■ EN55032:2012, Class A ■ Australian EMC Framework (RCM) ■ AS/NZS CISPR32:2015, Class A ■ Japan VCCI, Class A ■ Taiwan BSMI (CNS 13438), RoHS (CNS 15663), Class A ■ Korea MSIP, Class A ■ RoHS Compliant (Directive 2011/65/EU) ■ China RoHS compliant
Vibration, peak acceleration	0.25g (5 Hz to 500 Hz) (Sweep rate = 1 octave/minute)

3.1.2 LPe32000-Series HBAs and LPe31000-Series HBAs

Table 17: LPe32000-Series HBA and LPe31000-Series HBA Specifications

Parameter	Range
Physical dimensions	Low-profile form factor, 6.600 in. by 2.713 in.
Power requirements	Single-channel LPe31000 HBAs: 8.6W (typical), 9.6W (maximum) Single-channel LPe32000 HBAs: 8.8W (typical), 9.8W (maximum) Dual-channel LPe31002 HBAs: 9.3W (typical), 10.3W (maximum) Dual-channel LPe32002 HBAs: 9.6W (typical), 10.6W (maximum) Quad-channel LPe31004 HBAs: 11.1W (typical), 11.9W (maximum)
Power susceptibility	The HBAs can operate within the following voltage ranges: PCIe 3.3V: 3.3V ± 9% PCIe 12V: 12V ± 8% Power supply noise susceptibility: 100 mVpp at frequencies 100 kHz or less
Airflow	200 linear feet per minute (minimum)
Temperature	0°C to 55°C (operating) -20°C to 85°C (storage) NOTE: Operating HBAs in higher temperature conditions might result in early failure.
Humidity	5% to 95% (noncondensing, 22°C wet bulb) for storage 10% to 90% (noncondensing, 22°C wet bulb) for operation

Table 17: LPe32000-Series HBA and LPe31000-Series HBA Specifications (Continued)

Parameter	Range
Agency approvals	<ul style="list-style-type: none"> ■ Class 1 Laser Product per DHHS 21CFR (J) & EN60825-1 when equipped with approved optical devices ■ UL recognized to UL 62368-1:2014 ■ cUR recognized to CAN/CSA 22.2, No. 62368-1-14 ■ FCC Rules, Part 15, Class A ■ Industry Canada, ICES-003, Class A ■ EU (CE Mark) ■ UKCA ■ EN55024:2010 ■ EN55032:2012, Class A ■ Australian EMC Framework (RCM) ■ AS/NZSCISPR32:2015, Class A ■ Japan VCCI, Class A ■ Taiwan BSMI (CNS 13438), ROHS (CNS 15663), Class A ■ Korea MSIP, Class A ■ RoHS Compliant (Directive 2011/65/EU) ■ China RoHS compliant
Vibration, peak acceleration	0.25g (5 Hz to 500 Hz) (Sweep rate = 1 octave/minute)

3.1.3 LPe16000-Series HBAs and LPe15004 HBAs

Table 18: LPe16000-Series HBAs and LPe15004 HBA Specifications

Parameter	Range
Physical dimensions	LPe15004, LPe16000B, and LPe16002B HBAs: Low-profile form factor, 6.600 in. by 2.731 in. LPe16004 HBAs: Standard height, half-length form factor, 6.600 in. by 4.376 in.
Power requirements	Quad-channel LPe15004 HBAs: 11.5W (typical), 14.2W (maximum) Single-channel LPe16000B HBAs: 9.3W (typical), 11.6W (maximum) Dual-channel LPe16002B HBAs: 11.1W (typical), 13.3W (maximum) Quad-channel LPe16004 HBAs: 22.4W (typical), 25.0W (maximum)
Power susceptibility	The HBAs can operate within the following voltage ranges: PCIe 3.3V: 3.3V ± 9% PCIe 12V: 12V ± 8% Power supply noise susceptibility: 100 mVpp at frequencies 100 kHz or less
Airflow	LPe15004, LPe16000B, and LPe16002B HBAs: 200 linear feet per minute (minimum) LPe16004 HBAs: 250 linear feet per minute (minimum)
Temperature	LPe15004 HBAs: 0°C to 55°C (operating) LPe16000B, LPe16002B, and LPe16004 HBAs: 0°C to 50°C (operating) All HBAs: -40°C to 70°C (storage) NOTE: Operating HBAs in higher temperature conditions might result in early failure.
Humidity	LPe15004 HBAs: <ul style="list-style-type: none"> ■ 5% to 95% (noncondensing, 23°C wet bulb) for storage ■ 10% to 90% (noncondensing, 23°C wet bulb) for operation LPe16000B, LPe16002B, and LPe16004 HBAs: <ul style="list-style-type: none"> ■ 5% to 95% (noncondensing, 22°C wet bulb) for storage ■ 10% to 90% (noncondensing, 22°C wet bulb) for operation

Table 18: LPe16000-Series HBAs and LPe15004 HBA Specifications (Continued)

Parameter	Range
Agency approvals	<ul style="list-style-type: none"> ■ Class 1 Laser Product per DHHS 21CFR (J) and EN60825-1 when equipped with approved optical devices ■ UL recognized to UL 62368-1:2014 ■ cUR recognized to CAN/CSA 22.2, No. 62368-1-14 ■ FCC Rules, Part 15, Class A ■ Industry Canada, ICES-003, Class A ■ EMC Directive 2014/30/EUU (CE Mark) ■ UKCA ■ EN55032:2012, Class A ■ EN55024:2010 ■ Australian EMC Framework (RCM) ■ AS/NZS CISPR32:2015, Class A ■ Japan VCCI, Class A ■ Taiwan BSMI (CNS 13438), RoHS (CNS 15663), Class A ■ Korea MSIP, Class A ■ RoHS Compliant (Directive 2011/65/EU) ■ China RoHS compliant
Vibration, peak acceleration	0.25g (5 Hz to 500 Hz) (Sweep rate = 1 octave/minute)

3.1.4 LPe12000-Series HBAs and LPe1250 HBAs

Table 19: LPe12000-Series HBAs and LPe1250 HBA Specifications

Parameter	Range
Media interface	The controller connects to the physical media through an FC-0 media interface (FC-PH compliant transceiver), and then connects through dual optical-fiber LC connectors.
Physical dimensions	Low-profile MD2 form factor, 6.600 in. by 2.713 in. HBAs accommodate both full-height and low-profile brackets.

Table 19: LPe12000-Series HBAs and LPe1250 HBA Specifications (Continued)

Parameter	Range
Power requirements	LPe12004 HBAs: <ul style="list-style-type: none"> ■ 4.1 watts (typical) at +3.3V ± 9% ■ 4.7 watts (maximum) at +3.3V ± 9% ■ 15.3 watts (typical) at +12V ± 8% ■ 18.7 watts (maximum) at +12V ± 8% ■ 19.5 watts (typical) total ■ 23.5 watts (maximum) total
	LPe12002 HBAs: <ul style="list-style-type: none"> ■ 1.7 watts (typical) at +3.3V ± 9% ■ 2.0 watts (maximum) at +3.3V ± 9% ■ 7.1 watts (typical) at +12V ± 8% ■ 11.3 watts (maximum) at +12V ± 8% ■ 8.8 watts (typical) total ■ 13.3 watts (maximum) total
	LPe12000 HBAs: <ul style="list-style-type: none"> ■ 1.1 watts (typical) at +3.3V ± 9% ■ 1.3 watts (maximum) at +3.3V ± 9% ■ 5.8 watts (typical) at +12V ± 8% ■ 8.8 watts (maximum) at +12V ± 8% ■ 6.9 watts (typical) total ■ 10.1 watts (maximum) total
	NOTE: Because of differences in the SFP+ transceivers (short-wave vs. long-wave), the power is slightly higher (by 100 mW) on the +3.3V power for the long-wave product.
	LPe1250 HBAs: <ul style="list-style-type: none"> ■ 1.1 watts (typical) at +3.3V ± 9% ■ 1.3 watts (maximum) at +3.3V ± 9% ■ 4.8 watts (typical) at +12V ± 8% ■ 8.3 watts (maximum) at +12V ± 8% ■ 5.9 watts (typical) total ■ 9.6 watts (maximum) total
Airflow	150 linear feet per minute (minimum)
Temperature	0°C to 55°C (operating) –40°C to 70°C (storage)
Humidity	5% to 95% noncondensing
Agency approvals	<ul style="list-style-type: none"> ■ Class 1 Laser Product per DHHS 21CFR (J) & EN60825-1 when equipped with approved optical devices ■ UL recognized to UL 62368-1:2014 ■ cUR recognized to CAN/CSA 22.2, No. 62368-1-14 ■ FCC Rules, Part 15, Class A ■ Industry Canada, ICES-003, Class A ■ EMC Directive 2004/108/EC (CE Mark) EN55032:2012, Class A EN55024:2010 ■ Australian EMC Framework (C-Tick Mark) AS/NZS CISPR32:2015, Class A ■ Japan VCCI, Class A ■ Taiwan BSMI (CNS 13438), RoHS (CNS 15663), Class A ■ Korea MSIP, Class A ■ RoHS Compliant (Directive 2011/65/EU) ■ China RoHS compliant

3.2 FCC and Regulatory Notices

You can download the regulatory notices and certificates for Emulex HBAs at www.broadcom.com/emulex-regulatory.

3.2.1 FCC Supplier's Declarations of Confirmation (LPe36000-Series and LPe35000-Series HBAs Only)

3.2.1.1 LPe36000 HBAs, LPe36002 HBAs, LPe35000 HBAs, and LPe35002 HBAs

Supplier's Declaration of Confirmation (SDoC) for North America (FCC & ICES):

Product Name	Emulex ® HBA
Regulatory Model	P011814
Testing Laboratory	Element Materials Technology (Irvine CA) NVLAP 200676-0, ISED 2834B-1, 2834B-3
Compliance Report #	EMUL0092 Rev. 1
Compliance Report Date	June 29, 2018

This device complies with Part 15 of the FCC Rules. Operation is subject to the following two conditions: (1) This device may not cause harmful interference, and (2) this device must accept any interference received, including interference that may cause undesired operation.

Responsible Party: Jeff Hoogenboom, VP and General Manager of ECD
Emulex Corporation c/o Broadcom Inc. (408) 433-8000
1320 Ridder Park Drive, San Jose, CA 95131 USA

Note:

This equipment has been tested and found to comply with the limits for a Class A digital device, pursuant to part 15 of the FCC Rules. These limits are designed to provide reasonable protection against harmful interference when the equipment is operated in a commercial environment. This equipment generates, uses, and can radiate radio frequency energy and, if not installed and used in accordance with the instruction manual, may cause harmful interference to radio communications. Operation of this equipment in a residential area is likely to cause harmful interference in which case the user will be required to correct the interference at his own expense. Shielded cables must be used between this equipment and attached peripheral devices. The reader is cautioned that changes or modifications made to the equipment not expressly approved by Emulex could void the user's authority to operate this equipment.

July 1, 2019
San Jose, CA



Jeff Hoogenboom
VP and General Manager of ECD

This class A digital apparatus meets all requirements of the ISED (formerly Industry Canada) Interference - Causing Equipment Standard (ICES-003). **CAN ICES-3 (A)/ NMB-3 (A)**

3.2.1.2 LPe35004 HBAs

Supplier's Declaration of Confirmation (SDoC) for North America (FCC & ICES):

Product Name	Emulex ® HBA
Regulatory Model	P011836
Testing Laboratory	Element Materials Technology (Irvine CA) NVLAP 200676-0, ISED 2834B-1, 2834B-3
Compliance Report #	EMUL0091 Rev. 1
Compliance Report Date	May 25, 2018

This device complies with Part 15 of the FCC Rules. Operation is subject to the following two conditions: (1) This device may not cause harmful interference, and (2) this device must accept any interference received, including interference that may cause undesired operation.

Responsible Party: Jeff Hoogenboom, VP and General Manager of ECD
Emulex Corporation c/o Broadcom Inc. (408) 433-8000
1320 Ridder Park Drive, San Jose, CA 95131 USA

Note:

This equipment has been tested and found to comply with the limits for a Class A digital device, pursuant to part 15 of the FCC Rules. These limits are designed to provide reasonable protection against harmful interference when the equipment is operated in a commercial environment. This equipment generates, uses, and can radiate radio frequency energy and, if not installed and used in accordance with the instruction manual, may cause harmful interference to radio communications. Operation of this equipment in a residential area is likely to cause harmful interference in which case the user will be required to correct the interference at his own expense. Shielded cables must be used between this equipment and attached peripheral devices. The reader is cautioned that changes or modifications made to the equipment not expressly approved by Emulex could void the user's authority to operate this equipment.

July 1, 2019
San Jose, CA



Jeff Hoogenboom
VP and General Manager of ECD

This class A digital apparatus meets all requirements of the ISED (formerly Industry Canada) Interference - Causing Equipment Standard (ICES-003). **CAN ICES-3 (A)/ NMB-3 (A)**

3.2.2 Regulatory Notices

3.2.2.1 Notice for North America (FCC and ICES)

This device complies with Part 15 of the FCC Rules. Operation is subject to the following two conditions: (1) This device may not cause harmful interference, and (2) this device must accept any interference received, including interference that may cause undesired operation.

Responsible Party:

Jeff Hoogenboom, VP and General Manager of ECD
Emulex Corporation c/o Broadcom Inc. (408) 433-8000
1320 Ridder Park Drive, San Jose, CA 95131 USA

NOTE: This equipment has been tested and found to comply with the limits for a Class A digital device, pursuant to part 15 of the FCC Rules. These limits are designed to provide reasonable protection against harmful interference when the equipment is operated in a commercial environment. This equipment generates, uses, and can radiate radio frequency energy and, if not installed and used in accordance with the instruction manual, may cause harmful interference to radio communications. Operation of this equipment in a residential area is likely to cause harmful interference in which case the user will be required to correct the interference at his own expense. Shielded cables must be used between this equipment and attached peripheral devices. The reader is cautioned that changes or modifications made to the equipment not expressly approved by Emulex could void the user's authority to operate this equipment.

This class A digital apparatus meets all requirements of the ISED (formerly Industry Canada) Interference-Causing Equipment Standard (ICES-003). **CAN ICES-3 (A)/ NMB-3 (A)**

3.2.2.2 Notice for Japan and Translations (VCCI)

この装置は、クラスA情報技術装置です。この装置を家庭環境で使用すると電波妨害を引き起こすことがあります。この場合には使用者が適切な対策を講ずるよう要求されることがあります。 **VCCI-A**

This is a Class A product. In a domestic environment this product may cause radio interference in which case the user may be required to take adequate measures. VCCI—A.

3.2.2.3 Notice for Taiwan and Translations (BSMI)

警告使用者：
這是甲類的資訊產品，在居住的環境中使用時，可能會造成射頻干擾，在這種情況下，使用者會被要求採取某些適當的對策。

This equipment is a Class A ITE, and operation of this equipment in a residential area is likely to cause harmful interference, in which case users will be required to correct the interference at their own expense.

3.2.2.4 Notice for South Korea and Translations (MSIP)

이 기기는 업무용(A급) 전자파적합기기로서 판매사 또는 사용사는 이 섬을 수의하시기 바라며, 가정 외의 지역에서 사용하는 것을 목적으로 합니다.

Class A Equipment: Sellers and users of this equipment take note that this equipment is EMC approved for Class A industrial use, and as such is not intended for residential use.

3.2.3 Laser Safety Notice

Broadcom products incorporating optical laser transceivers contain Class 1 laser devices that comply with DHHS/CDRH 21CFR Sub-chapter J, and the international laser safety standard EN/IEC 60825-1. Class 1 laser devices are not considered to be hazardous.

The use of non-Broadcom approved optical transceivers, or transceivers that do not comply with the Class 1 radiation performance requirements defined in DHHS/CDRH 21CFR Sub-chapter J and IEC 60825-1, may expose the user to hazardous laser radiation, and such devices should not be used with Broadcom products.

CLASS 1 LASER PRODUCT
LASER KLASSE 1
LUOKAN 1 LASERLAITE
APPAREIL A LASER DE CLASSE 1

3.3 Declarations of Conformity

3.3.1 LPe36000 HBAs, LPe36002 HBAs, LPe35000 HBAs, and LPe35002 HBAs

Notice for European Union (CE-Mark):

DECLARATION OF CONFORMITY	
Manufacturer:	Emulex Corporation c/o Broadcom Inc. 1320 Ridder Park Drive San Jose, CA 95131 USA
declares under sole responsibility that the product:	
Product Name:	Emulex® HBA
Regulatory Model:	P011814
Assembly Number:	P011814-xxx
To which this Declaration relates is in conformity with the following standards or other documents for Information Technology Equipment (ITE):	
Product Safety:	Electromagnetic Compatibility (Class A):
UL Recognized to UL 62368-1:2014	FCC Rules, CFR Title 47, Part 15, Subpart B / ANS C63.4:2014
cUR Recognized to CAN/CSA 22.2, No. 62368-1-14	Industry Canada, ICES-003:2016 (Issue 5) +2014 update
IEC 62368-1:2014 (CB Scheme)	EN 55024:2010 / IEC 61000-4
EN 62368-1:2014 / A11:2017	EN 55032:2012 / CISPR 32:2015
EN 60825-1:2014*	AS/NZS CISPR 32:2015
CFR Title 21, Laser AEL Class 1, FDA/CDRH*	VCCI 32-1 / CISPR 32:2015
* when equipped with approved optical transceivers	CNS 13438:2006, KN32, KN35
Hazardous Substances:	
The object of this declaration described above is in conformity with Directive 2011/65/EU of the European Parliament and of the Council of 8 June 2011 on the restriction of the use of certain hazardous substances in electrical and electronic equipment, and has been validated per EN 50581:2012.	
Supplementary Information:	<ol style="list-style-type: none"> 1. The product was tested in a typical configuration. 2. The product is in compliance with the following directives: <ul style="list-style-type: none"> • European Union Low Voltage Directive 2014/35/EU • European Union EMC Directive 2014/30/EU and EU RoHS Directive 2011/65/EU • Australian RCM framework • Taiwan BSMI RoHS CNS 15663:2013.7
July 1, 2019 San Jose, CA	 Jeff Hoogenboom VP and General Manager of ECD
European Contact:	Avago Technologies Fiber GmbH, Wernerwerkstraße 2, 93049 Regensburg

Notice for UKCA:

Broadcom Inc.
1320 Ridder Park Drive
San Jose, CA 95131 USA
www.broadcom.com



DECLARATION OF CONFORMITY for UKCA

Supplier: Broadcom UK Ltd.
Address: 910 Hempton Court, Aztec West
Almondsbury, Bristol
BS32 4SR United Kingdom

Product Name: Emulex® HBA
Regulatory Model: P011814
Assembly Number: P011814-xxx

The product described above is in conformity with the relevant statutory requirements and standards listed below:

Low Voltage Directives 2014/35/EU
IEC 62368-1: 2014 (CB Scheme)

EMC Directives 2014/30/EU
EN55032:2012 + AC:2013
EN55024:2010

RoHS Recast Directive 2011/65/EU
EN 50581:2012

Additional Information
Report Number: EMUL0092
Test Laboratory: Element Materials Technology (NVLAP Lab Code: 200676-0)

A handwritten signature in black ink, appearing to read "Ben Chu".

Ben Chu
Engineering Manager
Emulex Corporation c/o Broadcom Inc.
15101 Alton Parkway
Irvine, CA 92618
(949) 926-1109
ben.chu@broadcom.com

Date: December 7, 2020

3.3.2 LPe35004 HBAs

Notice for European Union (CE-Mark):

DECLARATION OF CONFORMITY

Manufacturer: Emulex Corporation c/o Broadcom Inc.
1320 Ridder Park Drive
San Jose, CA 95131 USA

declares under sole responsibility that the product:

Product Name: Emulex® HBA
Regulatory Model: P011836
Assembly Number: P011836-xxx

To which this Declaration relates is in conformity with the following standards or other documents for Information Technology Equipment (ITE):

Product Safety:

UL Recognized to UL 62368-1:2014
cUR Recognized to CAN/CSA 22.2, No. 62368-1-14
IEC 62368-1:2014 (CB Scheme)
EN 62368-1:2014 / A11:2017
EN 60825-1:2014*
CFR Title 21, Laser AEL Class 1, FDA/CDRH*
* when equipped with approved optical transceivers

Electromagnetic Compatibility (Class A):

FCC Rules, CFR Title 47, Part 15, Subpart B / ANS C63.4:2014
Industry Canada, ICES-003:2016 (Issue 5) +2014 update
EN 55024:2010 / IEC 61000-4
EN 55032:2012 / CISPR 32:2015
AS/NZS CISPR 32:2015
VCCI 32-1 / CISPR 32:2015
CNS 13438:2006, KN32, KN35

Hazardous Substances:

The object of this declaration described above is in conformity with Directive 2011/65/EU of the European Parliament and of the Council of 8 June 2011 on the restriction of the use of certain hazardous substances in electrical and electronic equipment, and has been validated per EN 50581:2012.

Supplementary Information:

1. The product was tested in a typical configuration.
2. The product is in compliance with the following directives:
 - European Union Low Voltage Directive 2014/35/EU
 - European Union EMC Directive 2014/30/EU and EU RoHS Directive 2011/65/EU
 - Australian RCM framework
 - Taiwan BSMI RoHS CNS 15663:2013.7

July 1, 2019
San Jose, CA



Jeff Hoogenboom
VP and General Manager of ECD

European Contact: Avago Technologies Fiber GmbH, Wernerwerkstraße 2, 93049 Regensburg

Notice for UKCA:

Broadcom Inc.
1320 Ridder Park Drive
San Jose, CA 95131 USA
www.broadcom.com



DECLARATION OF CONFORMITY for UKCA

Supplier: Broadcom UK Ltd.
Address: 910 Hempton Court, Aztec West
Almondsbury, Bristol
BS32 4SR United Kingdom

Product Name: Emulex® HBA
Regulatory Model: P011836
Assembly Number: P011836-xxx

The product described above is in conformity with the relevant statutory requirements and standards listed below:

Low Voltage Directives 2014/35/EU
IEC 62368-1: 2014 (CB Scheme)

EMC Directives 2014/30/EU
EN55032:2012 + AC:2013
EN55024:2010

RoHS Recast Directive 2011/65/EU
EN 50581:2012

Additional Information
Report Number: EMUL0091.1
Test Laboratory: Element Materials Technology (NVLAP Lab Code: 200676-0)

A handwritten signature in black ink, appearing to read "Ben Chu".

Ben Chu
Engineering Manager
Emulex Corporation c/o Broadcom Inc.
15101 Alton Parkway
Irvine, CA 92618
(949) 926-1109
ben.chu@broadcom.com

Date: December 30, 2020

3.3.3 LPe31000 HBAs, LPe31002 HBAs, LPe32000 HBAs, and LPe32002 HBAs

Notice for European Union (CE-Mark):

DECLARATION OF CONFORMITY	
Manufacturer:	Emulex Corporation c/o Broadcom Inc. 1320 Ridder Park Drive San Jose, CA, 95131 USA
declares under sole responsibility that the product:	
Product Name:	Emulex® HBA
Regulatory Model:	P011324
Assembly Number:	P011324-xxx (<i>x=alphanumeric or blank</i>)
To which this Declaration relates is in conformity with the following standards or other documents for Information Technology Equipment (ITE):	
Product Safety:	Electromagnetic Compatibility (Class A):
UL Recognized to UL 62368-1:2014	FCC Rules, CFR Title 47, Part 15, Subpart B
cUR Recognized to CAN/CSA 22.2, No. 62368-1-14	Industry Canada, ICES-003:2012 (Issue 5) +2014 update
IEC 62368-1:2014 (CB Scheme)	EN55024:2010 / CISPR 24:2010
EN 62368-1:2014 / A11:2017	EN55032:2012 / CISPR 32:2015
EN 60825-1:2014*	AS/NZS CISPR 22:2009 +A1
CFR Title 21, Laser AEL Class 1, FDA/CDRH*	AS/NZS CISPR 32:2013
* when equipped with approved optical transceivers	VCCI:2014
	CNS 13438:2006, KN22, KN24
Hazardous Substances:	
The object of this declaration described above is in conformity with Directive 2011/65/EU of the European Parliament and of the Council of 8 June 2011 on the restriction of the use of certain hazardous substances in electrical and electronic equipment, and has been validated per EN 50581:2012.	
Supplementary Information:	<ol style="list-style-type: none"> 1. The product was tested in a typical configuration. 2. The product is in compliance with the following directives: <ul style="list-style-type: none"> • European Union Low Voltage Directives 2014/35/EU • European Union EMC Directives 2014/30/EU and EU RoHS Directives 2011/65/EU • Australian RCM framework • Taiwan BSMI RoHS CNS 15663:2013.7
<p>July 1, 2019 San Jose, CA</p>	 <p>Jeff Hoogenboom VP and General Manager of ECD</p>
European Contact:	Avago Technologies Fiber GmbH, Wernerwerkstraße 2, 93049 Regensburg

Notice for UKCA:

Broadcom Inc.
1320 Ridder Park Drive
San Jose, CA 95131 USA
www.broadcom.com



DECLARATION OF CONFORMITY for UKCA

Supplier: Broadcom UK Ltd.
Address: 910 Hempton Court, Aztec West
Almondsbury, Bristol
BS32 4SR United Kingdom

Product Name: Emulex® HBA
Regulatory Model: P011324
Assembly Number: P011324-xxx

The product described above is in conformity with the relevant statutory requirements and standards listed below:

Low Voltage Directives 2014/35/EU
IEC 62368-1: 2014 (CB Scheme)

EMC Directives 2014/30/EU
EN55032:2012 + AC:2013
EN55024:2010

RoHS Recast Directive 2011/65/EU
EN 50581:2012

Additional Information
Report Number: EMUL0069.0
Test Laboratory: Northwest EMC (NVLAP Lab Code: 200676-0)

A handwritten signature in black ink, appearing to read "Ben Chu".

Ben Chu
Engineering Manager
Emulex Corporation c/o Broadcom Inc.
15101 Alton Parkway
Irvine, CA 92618
(949) 926-1109
ben.chu@broadcom.com

Date: December 2, 2020

3.3.4 LPe31004 HBAs

Notice for European Union (CE-Mark):

DECLARATION OF CONFORMITY	
Manufacturer:	Emulex Corporation c/o Broadcom Inc. 1320 Ridder Park Drive San Jose, CA 95131 USA
declares under sole responsibility that the product:	
Product Name:	Emulex® HBA
Regulatory Model:	5189-1403
Assembly Number:	5189-1403
To which this Declaration relates is in conformity with the following standards or other documents for Information Technology Equipment (ITE):	
Product Safety:	Electromagnetic Compatibility (Class A):
UL Recognized to UL 62368-1:2014	FCC Rules, CFR Title 47, Part 15, Subpart B
cUR Recognized to CAN/CSA 22.2, No. 62368-1-14	Industry Canada, ICES-003:2012 (Issue 5) +2014 update
IEC 62368-1:2014 (CB Scheme)	EN 55024:2010 / CISPR 24:2010
EN 62368-1:2014 / A11:2017	EN 55032:2012 / CISPR 32:2015
EN 60825-1:2014*	EN 61000-3-2:2014
CFR Title 21, Laser AEL Class 1, FDA/CDRH*	EN 61000-3-3:2013
<i>* when equipped with approved optical transceivers</i>	AS/NZS CISPR 32:2013
	VCCI:2015
	CNS 13438:2006, KN32, KN35
Hazardous Substances:	
The object of this declaration described above is in conformity with Directive 2011/65/EU of the European Parliament and of the Council of 8 June 2011 on the restriction of the use of certain hazardous substances in electrical and electronic equipment, and has been validated per EN 50581:2012.	
Supplementary Information:	<ol style="list-style-type: none"> 1. The product was tested in a typical configuration. 2. The product is in compliance with the following directives: <ul style="list-style-type: none"> • European Union Low Voltage Directives 2014/35/EU • European Union EMC Directives 2014/30/EU and EU RoHS Directive 2011/65/EU • Australian RCM framework • Taiwan BSMI RoHS CNS 15663:2013.7
<p>July 1, 2019 San Jose, CA</p>	 Jeff Hoogenboom VP and General Manager of ECD
European Contact:	Avago Technologies Fiber GmbH, Wernerwerkstraße 2, 93049 Regensburg

Notice for UKCA:

Broadcom Inc.
1320 Ridder Park Drive
San Jose, CA 95131 USA
www.broadcom.com



DECLARATION OF CONFORMITY for UKCA

Supplier: Broadcom UK Ltd.
Address: 910 Hempton Court, Aztec West
Almondsbury, Bristol
BS32 4SR United Kingdom

Product Name: Emulex® HBA
Regulatory Model: 5189-1403
Assembly Number: 5189-1403-xxx

The product described above is in conformity with the relevant statutory requirements and standards listed below:

Low Voltage Directives 2014/35/EU
IEC 62368-1: 2014 (CB Scheme)

EMC Directives 2014/30/EU
EN55032:2012 + AC:2013
EN55024:2010

RoHS Recast Directive 2011/65/EU
EN 50581:2012

Additional Information
Report Number: EMUL0074
Test Laboratory: Northwest EMC (NVLAP Lab Code: 200676-0)

A handwritten signature in black ink, appearing to read "Ben Chu".

Ben Chu
Engineering Manager
Emulex Corporation c/o Broadcom Inc.
15101 Alton Parkway
Irvine, CA 92618
(949) 926-1109
ben.chu@broadcom.com

Date: December 30, 2020

3.3.5 LPe16000B HBAs and LPe16002B HBAs

Notice for European Union (CE-Mark):

DECLARATION OF CONFORMITY	
Manufacturer:	Emulex Corporation c/o Broadcom Inc. 1320 Ridder Park Drive San Jose, CA 95131 USA
declares under sole responsibility that the product:	
Product Name:	Emulex® HBA / OneConnect® UCNA
Regulatory Model:	P005947
Assembly Number:	P006002-xxx / P005947-xxx (<i>x=alphanumeric</i>)
To which this Declaration relates is in conformity with the following standards or other documents for Information Technology Equipment (ITE):	
Product Safety:	Electromagnetic Compatibility (Class A):
UL Recognized to UL 62368-1:2014	FCC Rules, CFR Title 47, Part 15, Subpart B
cUR Recognized to CAN/CSA 22.2, No. 62368-1-14	Industry Canada, ICES-003:2012 (Issue 5)
IEC 62368-1:2014 (CB Scheme)	EN 55032:2012/AC:2013 CISPR 32:2015
EN 62368-1:2014 / A11:2017	EN 55024:2010 / CISPR 24:2010
EN 60825-1:2014*	AS/NZS CISPR22:2009 +A1
CFR Title 21, Laser AEL Class 1, FDA/CDRH*	VCCI:2010
* when equipped with approved optical transceivers	CNS 13438:2006, KN 22, KN 24
Hazardous Substances:	
The object of this declaration described above is in conformity with Directive 2011/65/EU of the European Parliament and of the Council of 8 June 2011 on the restriction of the use of certain hazardous substances in electrical and electronic equipment, and has been validated per EN 50581:2012.	
Supplementary Information:	<ol style="list-style-type: none"> 1. The product was tested in a typical configuration. 2. The product is in compliance with the following directives: <ul style="list-style-type: none"> • European Union Low Voltage Directives 2014/35/EU • European Union EMC Directives 2014/30/EU and EU RoHS Directive 2011/65/EU • Australian RCM framework • Taiwan BSMI RoHS CNS 15663:2013.7
<p>July 1, 2019 San Jose, CA</p>	 Jeff Hoogenboom VP and General Manager of ECD
European Contact:	Avago Technologies Fiber GmbH, Wernerwerkstraße 2, 93049 Regensburg

Notice for UKCA:

Broadcom Inc.
1320 Ridder Park Drive
San Jose, CA 95131 USA
www.broadcom.com



DECLARATION OF CONFORMITY for UKCA

Supplier: Broadcom UK Ltd.
Address: 910 Hempton Court, Aztec West
Almondsbury, Bristol
BS32 4SR United Kingdom

Product Name: Emulex® HBA
Regulatory Model: P005947
Assembly Number: P005947-xxx

The product described above is in conformity with the relevant statutory requirements and standards listed below:

Low Voltage Directives 2014/35/EU
IEC 62368-1: 2014 (CB Scheme)

EMC Directives 2014/30/EU
EN55032:2012 + AC:2013
EN55024:2010

RoHS Recast Directive 2011/65/EU
EN 50581:2012

Additional Information
Report Number: EMUL0036
Test Laboratory: Northwest EMC (NVLAP Lab Code: 200676-0)

A handwritten signature in black ink, appearing to read "Ben Chu", is written over a horizontal dashed line.

Ben Chu
Engineering Manager
Emulex Corporation c/o Broadcom Inc.
15101 Alton Parkway
Irvine, CA 92618
(949) 926-1109
ben.chu@broadcom.com

Date: December 30, 2020

3.3.6 LPe16004 HBAs

Notice for European Union (CE-Mark):

DECLARATION OF CONFORMITY	
Manufacturer:	Emulex Corporation c/o Broadcom Inc. 1320 Ridder Park Drive San Jose, CA 95131 USA
declares under sole responsibility that the product:	
Product Name:	Emulex® HBA
Regulatory Model:	P007976
Assembly Number:	P007976-xxx (<i>x=alphanumeric</i>)
To which this Declaration relates is in conformity with the following standards or other documents for Information Technology Equipment (ITE):	
Product Safety:	Electromagnetic Compatibility (Class A):
UL Recognized to UL 62368-1:2014	FCC Rules, CFR Title 47, Part 15, Subpart B
cUR Recognized to CAN/CSA 22.2, No. 62368-1-14	Industry Canada, ICES-003:2012 (Issue 5)
IEC 62368-1:2014 (CB Scheme)	EN 55032:2012/AC:2013 CISPR 32:2015
EN 62368-1:2014 / A11:2017	EN 55024:2010 / CISPR 24:2010
EN 60825-1:2014*	AS/NZS CISPR22:2009 +A1
CFR Title 21, Laser AEL Class 1, FDA/CDRH*	VCCI:2010
* <i>when equipped with approved optical transceivers</i>	CNS 13438:2006 (complete), KN 22, KN 24
Hazardous Substances:	
The object of this declaration described above is in conformity with Directive 2011/65/EU of the European Parliament and of the Council of 8 June 2011 on the restriction of the use of certain hazardous substances in electrical and electronic equipment, and has been validated per EN 50581:2012.	
Supplementary Information:	<ol style="list-style-type: none"> The product was tested in a typical configuration. The product is in compliance with the following directives: <ul style="list-style-type: none"> European Union Low Voltage Directives 2014/35/EU European Union EMC Directives 2014/30/EU and EU RoHS Directive 2011/65/EU Australian RCM framework Taiwan BSMI RoHS CNS 15663:2013.7
<p>July 1, 2019 San Jose, CA</p>	 <p>Jeff Hoogenboom VP and General Manager of ECD</p>
European Contact:	Avago Technologies Fiber GmbH, Wernerwerkstraße 2, 93049 Regensburg

Notice for UKCA:

Broadcom Inc.
1320 Ridder Park Drive
San Jose, CA 95131 USA
www.broadcom.com



DECLARATION OF CONFORMITY for UKCA

Supplier: Broadcom UK Ltd.
Address: 910 Hempton Court, Aztec West
Almondsbury, Bristol
BS32 4SR United Kingdom

Product Name: Emulex® HBA
Regulatory Model: P007976
Assembly Number: P007976-xxx

The product described above is in conformity with the relevant statutory requirements and standards listed below:

Low Voltage Directives 2014/35/EU
IEC 62368-1: 2014 (CB Scheme)

EMC Directives 2014/30/EU
EN55032:2012 + AC:2013
EN55024:2010

RoHS Recast Directive 2011/65/EU
EN 50581:2012

Additional Information
Report Number: EMUL0044
Test Laboratory: Northwest EMC (NVLAP Lab Code: 200676-0)

A handwritten signature in black ink, appearing to read "Ben Chu", is written over a horizontal dashed line.

Ben Chu
Engineering Manager
Emulex Corporation c/o Broadcom Inc.
15101 Alton Parkway
Irvine, CA 92618
(949) 926-1109
ben.chu@broadcom.com

Date: December 2, 2020

3.3.7 LPe15004 HBAs

Notice for European Union (CE-Mark):

DECLARATION OF CONFORMITY	
Manufacturer:	Emulex Corporation c/o Broadcom Inc. 1320 Ridder Park Drive San Jose, CA 95131 USA
declares under sole responsibility that the product:	
Product Name:	Emulex® HBA
Regulatory Model:	P007729
Assembly Number:	P007729-xxx
To which this Declaration relates is in conformity with the following standards or other documents for Information Technology Equipment (ITE):	
<u>Product Safety:</u>	<u>Electromagnetic Compatibility (Class A):</u>
UL Recognized to UL 62368-1:2014	FCC Rules, CFR Title 47, Part 15, Subpart B
cUR Recognized to CAN/CSA 22.2, No. 62368-1-14	Industry Canada, ICES-003:2012 (Issue 5)
IEC 62368-1:2014 (CB Scheme)	EN 55032:2012/AC:2013 CISPR 32:2015
EN 62368-1:2014 / A11:2017	EN 55024:2010 / CISPR 24:2010
EN 60825-1:2014	AS/NZS CISPR22:2009 +A1
CFR Title 21, Laser AEL Class 1, FDA/CDRH	VCCI:2012
	CNS 13438:2006 (Complete), KN 22, KN 24
<u>Hazardous Substances:</u>	
The object of this declaration described above is in conformity with Directive 2011/65/EU of the European Parliament and of the Council of 8 June 2011 on the restriction of the use of certain hazardous substances in electrical and electronic equipment, and has been validated per EN 50581:2012.	
Supplementary Information:	<ol style="list-style-type: none"> 1. The product was tested in a typical configuration. 2. The product is in compliance with the following directives: <ul style="list-style-type: none"> • European Union Low Voltage Directives 2014/35/EU • European Union EMC Directives 2014/30/EU and EU RoHS Directive 2011/65/EU • Australian RCM framework • Taiwan BSMI RoHS CNS 15663:2013.7
<p>July 1, 2019 San Jose, CA</p>	 <p>Jeff Hoogenboom VP and General Manager of ECD</p>
European Contact:	Avago Technologies Fiber GmbH, Wernerwerkstraße 2, 93049 Regensburg

3.3.8 LPe12002 HBAs, LPe12000 HBAs, and LPe1250 HBAs

Notice for European Union (CE-Mark):

DECLARATION OF CONFORMITY	
Manufacturer:	Emulex Corporation c/o Broadcom Inc. 1320 Ridder Park Drive San Jose, CA. 95131 USA
declares under sole responsibility that the product:	
Product Name:	Emulex® HBA
Regulatory Model:	P001219
Assembly Number:	P002181-xxx / P001219-xxx (<i>x=alphanumeric</i>)
To which this Declaration relates is in conformity with the following standards or other documents for Information Technology Equipment (ITE):	
Product Safety:	Electromagnetic Compatibility (Class A):
UL Recognized to UL 62368-1:2014	FCC Rules, CFR Title 47, Part 15, Subpart B
cUR Recognized to CAN/CSA 22.2, No. 62368-1-14	Industry Canada, ICES-003:2012 (Issue 5)
IEC 62368-1:2014 (CB Scheme)	EN 55032:2012/AC:2013 CISPR 32:2015
EN 62368-1:2014 / A11:2017	EN55024:2010 / CISPR 24:2010
EN 60825-1:2014*	AS/NZS CISPR22:2009 +A1
CFR Title 21, Laser AEL Class 1, FDA/CDRH*	VCCI:2010
* <i>when equipped with approved optical transceivers</i>	CNS 13438:2006, KN22, KN24
Hazardous Substances:	
The object of this declaration described above is in conformity with Directive 2011/65/EU of the European Parliament and of the Council of 8 June 2011 on the restriction of the use of certain hazardous substances in electrical and electronic equipment, and has been validated per EN 50581:2012.	
Supplementary Information:	<ol style="list-style-type: none"> 1. The product was tested in a typical configuration. 2. The product is in compliance with the following directives: <ul style="list-style-type: none"> • European Union Low Voltage Directives 2014/35/EU • European Union EMC Directives 2014/30/EU and EU RoHS Directive 2011/65/EU • Australian RCM framework • Taiwan BSMI RoHS CNS 15663:2013.7
<p>July 1, 2019 San Jose, CA</p>	 <p>Jeff Hoogenboom VP and General Manager of ECD</p>
European Contact:	Avago Technologies Fiber GmbH, Wernerwerkstraße 2, 93049 Regensburg

3.3.9 LPe12004 HBAs

Notice for European Union (CE-Mark):

DECLARATION OF CONFORMITY	
Manufacturer:	Emulex Corporation c/o Broadcom Inc. 1320 Ridder Park Drive San Jose, CA. 95131 USA
declares under sole responsibility that the product:	
Product Name:	Emulex® HBA
Regulatory Model:	P003797
Assembly Number:	P003927-xxx / P003798-xxx (<i>x=alphanumeric</i>)
To which this Declaration relates is in conformity with the following standards or other documents for Information Technology Equipment (ITE):	
Product Safety:	Electromagnetic Compatibility (Class A):
UL Recognized to UL 62368-1:2014	FCC Rules, CFR Title 47, Part 15, Subpart B
cUR Recognized to CAN/CSA 22.2, No. 62368-1-14	Industry Canada, ICES-003:2012 (Issue 5)
IEC 62368-1:2014 (CB Scheme)	EN 55032:2012/AC:2013 CISPR 32:2015
EN 62368-1:2014 / A11:2017	EN 55024:2010 / CISPR 24:2010
EN 60825-1:2014*	AS/NZS CISPR22:2009 +A1
CFR Title 21, Laser AEL Class 1, FDA/CDRH*	VCCI:2010
* <i>when equipped with approved optical transceivers</i>	CNS 13438:2006, KN 22, KN 24
Hazardous Substances:	
The object of this declaration described above is in conformity with Directive 2011/65/EU of the European Parliament and of the Council of 8 June 2011 on the restriction of the use of certain hazardous substances in electrical and electronic equipment, and has been validated per EN 50581:2012.	
Supplementary Information:	<ol style="list-style-type: none"> 1. The product was tested in a typical configuration. 2. The product is in compliance with the following directives: <ul style="list-style-type: none"> • European Union Low Voltage Directives 2014/35/EU • European Union EMC Directives 2014/30/EU and EU RoHS Directive 2011/65/EU • Australian RCM framework • Taiwan BSMI RoHS CNS 15663:2013.7
July 1, 2019 San Jose, CA	 Jeff Hoogenboom VP and General Manager of ECD
European Contact:	Avago Technologies Fiber GmbH, Wernerwerkstraße 2, 93049 Regensburg

3.4 Taiwan RoHS Notices

3.4.1 LPe36000 HBAs, LPe36002 HBAs, LPe35000 HBAs, and LPe35002 HBAs

The following illustration provides the Taiwan RoHS notice for the P011814 RMN.

限用物質含有情況標示聲明書
Declaration of the Presence Condition of the Restricted Substances Marking

證書號碼／受理編號：符合性聲明商品
Certificate No. / Application No.

商品標籤及商品檢驗標識：(Picture)
Product Label and Commodity Inspection Mark.

樣張及其標示位置：(Description and Picture)
Sample and its location

設備名稱: LPe35000/2-M2, 1 or 2 Port 32G FC HBA; 型號 (型式): P011814 Equipment name: Type designation (Type)		限用物質及其化學符號 Restricted substances and its chemical symbols				
單元 Unit	鉛Lead (Pb)	汞Mercury (Hg)	鎘Cadmium (Cd)	六價鉻Hexavalent chromium (Cr ⁺⁶)	多溴聯苯Polybrominated biphenyls (PBB)	多溴二苯醚Polybrominated diphenyl ethers (PBDE)
電子被動元件 Passive Components	—	○	○	○	○	○
電路板 Printed Circuit Board	○	○	○	○	○	○
連接器 Connector/ Mechanical	○	○	○	○	○	○
集成電路 Active Devices	○	○	○	○	○	○

備考1. “超出0.1 wt %”及“超出0.01 wt %”係指限用物質之百分比含量超出百分比含量基準值。
Note 1: “Exceeding 0.1 wt %” and “exceeding 0.01 wt %” indicate that the percentage content of the restricted substance exceeds the reference percentage value of presence condition.

備考2. “○”係指該項限用物質之百分比含量未超出百分比含量基準值。
Note 2: “○” indicates that the percentage content of the restricted substance does not exceed the percentage of reference value of presence.

備考3. “—”係指該項限用物質為排除項目。
Note 3: The “—” indicates that the restricted substance corresponds to the exemption.

茲切結保證所提供之商品限用物質含有情況標示內容係經執行測試作業或採適當之品質管理措施，並備置前述相關文件，確認正確無誤後提供貴局。並同意配合貴局執行後市場管理作業所需，依商品檢驗法第49條之規定，於限期28個工作天內提供相關證明文件以供審查。

I hereby ensure that “the presence conditions of the restricted substance” provided above have been proved by testing or appropriate quality control measures, and make sure the relevant documents provided are correct and ready. Also, I agree to cooperate with BSMI, as the Article 49 of the Commodity Inspection Act stipulates, to provide the relevant documents, if needed, for verification within 28 working days when BSMI carries out the market surveillance activities.

此致 to

經濟部標準檢驗局 The Bureau of Standards, Metrology and Inspection

申請人：精訊電子科技有限公司
Applicant

負責人：林冠宏 (簽章)
Person in charge (Signature)

中華民國 107 年 07 月 09 日
DATE (year) (month) (day)

3.4.2 LPe35004 HBAs

The following illustration provides the Taiwan RoHS notice for the P011836 RMN.

限用物質含有情況標示聲明書

Declaration of the Presence Condition of the Restricted Substances Marking

證書號碼/受理編號：符合性聲明商品
Certificate No./Application No.

商品標籤及商品檢驗標識：(Picture)
Product Label and Commodity Inspection Mark.

樣張及其標示位置：(Description and Picture)
Sample and its location

設備名稱: LPe35004-S3, 4 Port 32G FC HBA; 型號 (型式) : P011836 Equipment name Type designation (Type)		限用物質及其化學符號 Restricted substances and its chemical symbols				
單元 Unit	鉛Lead (Pb)	汞Mercury (Hg)	鎘Cadmium (Cd)	六價鉻 Hexavalent chromium (Cr ⁺⁶)	多溴聯苯 Polybrominated biphenyls (PBB)	多溴二苯醚 Polybrominated diphenyl ethers (PBDE)
電子被動元件 Passive Components	—	○	○	○	○	○
電路板 Printed Circuit Board	○	○	○	○	○	○
連接器 Connector/ Mechanical	○	○	○	○	○	○
集成電路 Active Devices	○	○	○	○	○	○

備考1. “超出0.1 wt %”及“超出0.01 wt %”係指限用物質之百分比含量超出百分比含量基準值。
Note 1: “Exceeding 0.1 wt %” and “exceeding 0.01 wt %” indicate that the percentage content of the restricted substance exceeds the reference percentage value of presence condition.

備考2. “○”係指該項限用物質之百分比含量未超出百分比含量基準值。
Note 2: “○” indicates that the percentage content of the restricted substance does not exceed the percentage of reference value of presence.

備考3. “—”係指該項限用物質為排除項目。
Note 3: The “—” indicates that the restricted substance corresponds to the exemption.

茲切結保證所提供之商品限用物質含有情況標示內容係經執行測試作業或採適當之品質管理措施，並備置前述相關文件，確認正確無誤後提供貴局。並同意配合貴局執行後市場管理作業所需，依商品檢驗法第49條之規定，於限期28個工作天內提供相關證明文件以供審查。

I hereby ensure that “the presence conditions of the restricted substance” provided above have been proved by testing or appropriate quality control measures, and make sure the relevant documents provided are correct and ready. Also, I agree to cooperate with BSMI, as the Article 49 of the Commodity Inspection Act stipulates, to provide the relevant documents, if needed, for verification within 28 working days when BSMI carries out the market surveillance activities.

此致 to

經濟部標準檢驗局 The Bureau of Standards, Metrology and Inspection

申請人：精訊電子科技有限公司
Applicant

負責人：林冠宏
Person in charge



(簽章)
(Signature)

中華民國 107 年 05 月 30 日
DATE (year) (month) (day)

3.4.3 LPe31000-Series HBAs and LPe32000-Series HBAs

The following table provides the Taiwan RoHS notice for the following RMNs:

- 5189-1403
- P011324
- P011687
- P011712

設備名稱:

Equipment name : LightPulse Fibre Channel Adapter Card

型號 (型式)

Type designation (Type) : Board Assemblies

單元Unit	限用物質及其化學符號 Restricted substances and their chemical symbols					
	鉛Lead (Pb)	汞Mercury (Hg)	鎘Cadmium (Cd)	六價鉻 Hexavalent chromium (Cr+6)	多溴聯苯 Polybrominated biphenyls (PBB)	多溴二苯醚 Polybrominated diphenyl ethers (PBDE)
电子被動元件- Passive Components	—	○	○	○	○	○
電路板- Printed Circuit Board	○	○	○	○	○	○
集成电路- Active Devices	○	○	○	○	○	○
連接器 - Connector/ Mechanical	○	○	○	○	○	○

備考1. “超出0.1 wt %”及“超出0.01 wt %”係指限用物質之百分比含量超出百分比含量基準值。

NOTE: “Exceeding 0.1 wt %” and “exceeding 0.01 wt %” indicate that the percentage content of the restricted substance exceeds the reference percentage value of presence condition.

備考2. “○”係指該項限用物質之百分比含量未超出百分比含量基準值。

NOTE: “○” indicates that the percentage content of the restricted substance does not exceed the percentage of reference value of presence.

備考3. “—”係指該項限用物質為排除項目。

NOTE: The “—” indicates that the restricted substance corresponds to the exemption.

The following table provides the Taiwan RoHS notice for the 5067-5396 RMN.

設備名稱:

Equipment name : LightPulse Fibre Channel Adapter Card

型號 (型式)

Type designation (Type) : Board Assemblies

單元Unit	限用物質及其化學符號 Restricted substances and their chemical symbols					
	鉛Lead (Pb)	汞Mercury (Hg)	鎘Cadmium (Cd)	六價鉻 Hexavalent chromium (Cr+6)	多溴聯苯 Polybrominated biphenyls (PBB)	多溴二苯醚 Polybrominated diphenyl ethers (PBDE)
電子被動元件- Passive Components	—	○	○	○	○	○
電路板- Printed Circuit Board	○	○	○	○	○	○
連接器 - Connector/ Mechanical	○	○	○	○	○	○
集成電路- Active Devices	○	○	○	○	○	○
光纖收發器- Optical Transceiver	—	○	○	○	○	○

備考1. “超出0.1 wt %”及“超出0.01 wt %”係指限用物質之百分比含量超出百分比含量基準值。

NOTE: “Exceeding 0.1 wt %” and “exceeding 0.01 wt %” indicate that the percentage content of the restricted substance exceeds the reference percentage value of presence condition.

備考2. “○”係指該項限用物質之百分比含量未超出百分比含量基準值。

NOTE: “○” indicates that the percentage content of the restricted substance does not exceed the percentage of reference value of presence.

備考3. “—”係指該項限用物質為排除項目。

NOTE: The “—” indicates that the restricted substance corresponds to the exemption.

3.4.4 LPe16000B-Series HBAs, LPe16004 HBAs, and LPe15004 HBAs

The following table provides the Taiwan RoHS notice for the P011095 RMN.

設備名稱:

Equipment name: LightPulse Fibre Channel Adapter Card

型號 (型式)

Type designation (Type): Board Assemblies

單元Unit	限用物質及其化學符號 Restricted substances and its chemical symbols					
	鉛Lead (Pb)	汞Mercury (Hg)	鎘Cadmium (Cd)	六價鉻 Hexavalent chromium (Cr ⁺⁶)	多溴聯苯 Polybrominated biphenyls (PBB)	多溴二苯醚 Polybrominated diphenyl ethers (PBDE)
电子被動元件- Passive Components	—	○	○	○	○	○
電路板- Printed Circuit Board	○	○	○	○	○	○
集成电路- Active Devices	○	○	○	○	○	○
連接器- Connector/ Mechanical	○	○	○	○	○	○

備考1. “超出0.1 wt %”及“超出0.01 wt %”係指限用物質之百分比含量超出百分比含量基準值。

Note 1: “Exceeding 0.1 wt %” and “exceeding 0.01 wt %” indicate that the percentage content of the restricted substance exceeds the reference percentage value of presence condition.

備考2. “○”係指該項限用物質之百分比含量未超出百分比含量基準值。

Note 2: “○” indicates that the percentage content of the restricted substance does not exceed the percentage of reference value of presence.

備考3. “—”係指該項限用物質為排除項目。

Note 3: The “—” indicates that the restricted substance corresponds to the exemption.

The following table provides the Taiwan RoHS notice for the following RMNs:

- P005947
- P006931
- P007316
- P007729
- P007976
- P010225

設備名稱:

Equipment name: LightPulse Fibre Channel Adapter Card

型號 (型式)

Type designation (Type): Board Assemblies

單元Unit	限用物質及其化學符號 Restricted substances and its chemical symbols					
	鉛Lead (Pb)	汞Mercury (Hg)	鎘Cadmium (Cd)	六價鉻Hexavalent chromium (Cr ⁺⁶)	多溴聯苯Polybrominated biphenyls (PBB)	多溴二苯醚Polybrominated diphenyl ethers (PBDE)
电子被动元件- Passive Components	—	○	○	○	○	○
电路板- Printed Circuit Board	○	○	○	○	○	○
连接器- Connector/ Mechanical	○	○	○	○	○	○
集成电路- Active Devices	○	○	○	○	○	○
光纖收發器- Optical Transceiver	—	○	○	○	○	○

備考1. “超出0.1 wt %”及“超出0.01 wt %”係指限用物質之百分比含量超出百分比含量基準值。

Note 1: “Exceeding 0.1 wt %” and “exceeding 0.01 wt %” indicate that the percentage content of the restricted substance exceeds the reference percentage value of presence condition.

備考2. “○”係指該項限用物質之百分比含量未超出百分比含量基準值。

Note 2: “○” indicates that the percentage content of the restricted substance does not exceed the percentage of reference value of presence.

備考3. “—”係指該項限用物質為排除項目。

Note 3: The “—” indicates that the restricted substance corresponds to the exemption.

3.4.5 LPe12000-Series HBAs and LPe1250 HBAs

The following table provides the Taiwan RoHS notice for the following RMNs:

- P001219
- P003797

設備名稱:

Equipment name : LightPulse Fibre Channel Adapter Card

型號 (型式)

Type designation (Type) : Board Assemblies

單元 Unit	限用物質及其化學符號 Restricted substances and their chemical symbols					
	鉛 Lead (Pb)	汞 Mercury (Hg)	鎘 Cadmium (Cd)	六價鉻 Hexavalent chromium (Cr+6)	多溴聯苯 Polybrominated biphenyls (PBB)	多溴二苯醚 Polybrominated diphenyl ethers (PBDE)
电子被動元件- Passive Components	—	○	○	○	○	○
電路板- Printed Circuit Board	○	○	○	○	○	○
連接器 - Connector/ Mechanical	○	○	○	○	○	○
集成电路- Active Devices	○	○	○	○	○	○
光纖收發器- Optical Transceiver	—	○	○	○	○	○

備考1. “超出0.1 wt%”及“超出0.01 wt%”係指限用物質之百分比含量超出百分比含量基準值。

Note 1: “Exceeding 0.1 wt%” and “exceeding 0.01 wt%” indicate that the percentage content of the restricted substance exceeds the reference percentage value of presence condition.

備考2. “○”係指該項限用物質之百分比含量未超出百分比含量基準值。

Note 2: “○” indicates that the percentage content of the restricted substance does not exceed the percentage of reference value of presence.

備考3. “—”係指該項限用物質為排除項目。

Note 3: The “—” indicates that the restricted substance corresponds to the exemption.

