

# ET51/56

## Enterprise Tablet



## Product Reference Guide for Android™ 10



ZEBRA and the stylized Zebra head are trademarks of Zebra Technologies Corporation, registered in many jurisdictions worldwide. Google, Android, Google Play and other marks are trademarks of Google LLC. All other trademarks are the property of their respective owners. ©2020 Zebra Technologies Corporation and/or its affiliates. All rights reserved.

COPYRIGHTS & TRADEMARKS: For complete copyright and trademark information, go to [zebra.com/copyright](http://zebra.com/copyright).

WARRANTY: For complete warranty information, go to [zebra.com/warranty](http://zebra.com/warranty).

END USER LICENSE AGREEMENT: For complete EULA information, go to [zebra.com/eula](http://zebra.com/eula).

## Terms of Use

- Proprietary Statement

This manual contains proprietary information of Zebra Technologies Corporation and its subsidiaries (“Zebra Technologies”). It is intended solely for the information and use of parties operating and maintaining the equipment described herein. Such proprietary information may not be used, reproduced, or disclosed to any other parties for any other purpose without the express, written permission of Zebra Technologies.

- Product Improvements

Continuous improvement of products is a policy of Zebra Technologies. All specifications and designs are subject to change without notice.

- Liability Disclaimer

Zebra Technologies takes steps to ensure that its published Engineering specifications and manuals are correct; however, errors do occur. Zebra Technologies reserves the right to correct any such errors and disclaims liability resulting therefrom.

- Limitation of Liability

In no event shall Zebra Technologies or anyone else involved in the creation, production, or delivery of the accompanying product (including hardware and software) be liable for any damages whatsoever (including, without limitation, consequential damages including loss of business profits, business interruption, or loss of business information) arising out of the use of, the results of use of, or inability to use such product, even if Zebra Technologies has been advised of the possibility of such damages. Some jurisdictions do not allow the exclusion or limitation of incidental or consequential damages, so the above limitation or exclusion may not apply to you.

## Revision History

Changes to the original guide are listed below:

Change	Date	Description
-01EN Rev A	10/2020	Initial release.
-02EN Rev. A	3/2021	Change charging LED from Orange to Blinking Amber.
-03EN Rev. A	9/2021	Correct hard reset key combo. Add new tall insert for Charge Only Cradle. Update GSM Restricted section.
-04EN Rev. A	12/2021	Remove beep alert note on page 78.

# Table of Contents

Terms of Use.....	2
Revision History .....	2
<b>About This Guide.....</b>	<b>12</b>
Configurations.....	12
Related Documents and Software .....	13
Notational Conventions .....	13
Icon Conventions .....	14
Service Information .....	14
Determining Software Versions.....	14
Determining the Serial Number.....	15
<b>Getting Started.....</b>	<b>16</b>
Introduction .....	16
Unpacking .....	16
ET51/56 Features .....	17
ET51 with Integrated Scanner Features .....	19
Getting Started .....	21
Installing a microSD Card .....	21
Install the microSD Card .....	22
Install the nano SIM Card.....	23
Charging the Battery.....	26
Google Account Setup.....	26
Turning Off the Tablet .....	26
Replacing the SIM Card .....	26
Replacing the microSD Card.....	27
Interactive Sensor Technology.....	27
Turning Off the Display .....	27

<b>Using the Device</b> .....	<b>28</b>
Home Screen .....	28
Setting Home Screen Rotation .....	29
Status Bar .....	29
Notification Icons .....	30
Status Icons .....	31
Managing Notifications .....	32
Opening the Quick Access Panel .....	33
Quick Access Panel Icons.....	33
Editing Icons on the Quick Settings Bar .....	34
Battery Management.....	34
Checking Battery Status .....	34
Monitoring Battery Usage .....	35
Low Battery Notification .....	35
Interactive Sensor Technology.....	35
Waking the Device .....	35
USB Communication.....	36
Transferring Files.....	36
Transferring Photos .....	36
Disconnect from the Host Computer .....	37
<b>Settings</b> .....	<b>38</b>
Accessing Settings.....	38
Display Settings .....	38
Setting the Screen Brightness Manually.....	38
Setting the Screen Brightness Automatically.....	38
Setting Night Light .....	38
Setting Screen Rotation.....	39
Setting Screen Timeout.....	39
Lock Screen Display .....	39
Setting Font Size .....	40
Touch Panel Mode .....	40
Setting the Date and Time .....	40
General Sound Setting.....	41
Sound Options.....	41
Remapping a Button .....	42
Remappable Keys.....	42
Keyboards .....	42
Keyboard Configuration.....	43
Enabling Keyboards.....	43
Switching Between Keyboards.....	43

## Table of Contents

Using the Android and Gboard Keyboards .....	43
Edit Text .....	43
Entering Numbers, Symbols, and Special Characters .....	43
Using the Enterprise Keyboard .....	43
Numeric Tab .....	44
Alpha Tab .....	44
Additional Character Tab .....	44
Scan Tab .....	44
Language Usage .....	44
Changing the Language Setting .....	44
Adding Words to the Dictionary .....	44
Notifications .....	45
Setting App Notifications .....	45
Viewing Notification Settings for All Apps .....	45
Controlling Lock Screen Notifications .....	45
Blink Light .....	46
<b>Applications .....</b>	<b>1</b>
Accessing Apps .....	4
Switching Between Recent Apps .....	4
Battery Manager .....	4
Opening Battery Manager .....	4
Battery Manager Information Tab .....	5
Camera .....	7
Taking Photos .....	7
Taking a Panoramic Photo .....	8
Recording Videos .....	8
Photo Settings .....	9
Rear Camera Photo Settings .....	9
Front Camera Photo Settings .....	10
Video Settings .....	11
Rear Camera Video Settings .....	11
Front Camera Video Settings .....	12
DataWedge Demonstration .....	12
Scanner Selection .....	13
RxLogger .....	14
RxLogger Configuration .....	14
Configuration File .....	14
Enabling Logging .....	14
Disabling Logging .....	14
Extracting Log Files .....	14
Backing Up .....	14

## Table of Contents

RxLogger Utility .....	15
Initiating the Main Chat Head.....	15
Removing the Main Chat Head .....	15
Viewing Logs.....	15
Removing a Sub Chat Head Icon.....	15
Backing Up In Overlay View.....	15
Sound Recorder .....	15
VC Settings .....	17
Display .....	17
Screen Blanking .....	17
<b>Data Capture .....</b>	<b>18</b>
Imaging .....	18
Scanning Considerations .....	18
Expansion Back .....	19
Integrated Scanner.....	19
RS507/RS507X Hands-Free Imager.....	19
RS5100 Ring Scanner .....	19
RS6000 Bluetooth Ring Scanner .....	20
DS36X8 Digital Scanner .....	20
DS2278 Digital Scanner.....	21
DS8178 Scanner.....	21
Scanning with SE4750 Expansion Back .....	22
Scanning with the Integrated Scanner .....	23
Scanning with RS507/RS507X Hands-Free Imager .....	24
Scanning with RS5100 Ring Scanner .....	25
Scanning with RS6000 Bluetooth Ring Scanner.....	27
Scanning with the DS36X8 Scanner .....	28
Scanning with DS2278 Digital Scanner .....	29
Scanning with DS8178 Digital Scanner .....	30
Pairing the RS507/RS5100/RS6000 Ring Scanner .....	30
Pairing Using Simple Serial Interface (SSI).....	30
Pairing Using Bluetooth Human Interface Device .....	31
Pairing a Bluetooth Scanner .....	32
Pairing Using Simple Serial Interface .....	32
Pairing Using Bluetooth Human Interface Device .....	32
Connecting a USB Scanner .....	33
Connecting Using Simple Serial Interface .....	33
Connecting Using HID Mode .....	33
DataWedge .....	33
Enabling DataWedge.....	34

## Table of Contents

Disabling DataWedge.....	34
Supported Decoders.....	34
<b>Wireless.....</b>	<b>37</b>
Wireless Wide Area Networks.....	37
Sharing the Mobile Data Connection.....	37
Enabling USB Tethering.....	37
Enabling Bluetooth Tethering.....	38
Enabling Wi-Fi Hotspot.....	38
Configuring the Wi-Fi Hotspot.....	38
Data Usage.....	39
Setting Data Usage Warning.....	39
Setting Data Limit.....	39
Cellular Network Settings.....	40
Data When Roaming.....	40
Setting Preferred Network.....	40
Using Search for MicroCell.....	40
Configuring the Access Point Name.....	40
Locking the SIM Card.....	41
Wireless Local Area Networks.....	41
Connecting to a Wi-Fi Network.....	42
Removing a Wi-Fi Network.....	42
WLAN Configuration.....	42
Configuring a Secure Wi-Fi Network.....	42
Manually Adding a Wi-Fi Network.....	43
Configuring for a Proxy Server.....	45
Configuring the Device to Use a Static IP Address.....	45
Wi-Fi Preferences.....	46
Additional Wi-Fi Settings.....	46
Wi-Fi Direct.....	47
Bluetooth.....	47
Adaptive Frequency Hopping.....	47
Security.....	48
Bluetooth Profiles.....	48
Bluetooth Power States.....	49
Bluetooth Radio Power.....	49
Enabling Bluetooth.....	50
Disabling Bluetooth.....	50
Discovering Bluetooth Device(s).....	50
Changing the Bluetooth Name.....	50
Connecting to a Bluetooth Device.....	50
Selecting Profiles on the Bluetooth Device.....	51

## Table of Contents

Unpairing a Bluetooth Device .....	51
Cast.....	51
Near Field Communications.....	51
Reading NFC Cards .....	52
Enterprise NFC Settings.....	52
<b>Accessories.....</b>	<b>54</b>
Introduction .....	54
Battery Charging .....	56
Main Battery Charging.....	56
Charging Temperature .....	57
Charge Only Cradle .....	58
Installing the Short Insert.....	59
Installing the Tall Insert.....	59
Charging the Device .....	60
Communication and Charging Cradle .....	62
Installing the Insert .....	63
Charging the Device .....	64
Rugged Communication and Charging Cradle .....	66
Charging the Device .....	67
4-Slot Charge Only Cradle .....	69
Power Setup .....	70
Insert Installation .....	71
Battery Charger Installation .....	73
Insert Tablet into Slot.....	73
Device without Rugged Frame.....	73
Device with Rugged Frame.....	74
Battery Charger Installation .....	75
Rugged Charge Connector .....	76
Power Pack.....	78
Charging the Power Pack.....	79
Using Cradle .....	79
Using the 4-Slot Battery Charger .....	80
Charging the Power Pack.....	80
Rugged Frame .....	82
Expansion Back .....	85
Installation .....	85
Replacement Hand Strap .....	87
Attaching the Stylus to the Expansion Back.....	91
Removal .....	92
ET51 with Integrated Scanner Hand Strap .....	95



## Table of Contents

Removing the Hand Strap .....	95
Installing the Hand Strap on the Back of the Device .....	95
Installing the Hand Strap on the Side of the Device .....	97
<b>Application Deployment.....</b>	<b>99</b>
Security .....	99
Secure Certificates.....	99
Installing a Secure Certificate .....	99
Configuring Credential Storage Settings .....	100
Development Tools .....	100
Android Application Development .....	100
Development Workstation .....	100
Enabling Developer Options .....	100
EMDK for Android.....	101
StageNow .....	101
GMS Restricted.....	101
ADB USB Setup .....	101
Enabling USB Debugging.....	101
Entering Android Recovery Manually .....	102
Application Installation .....	102
Installing Applications Using the USB Connection .....	103
Installing Applications Using the Android Debug Bridge .....	103
Installing Applications Using a microSD Card .....	104
Uninstalling an Application .....	104
Performing a System Update.....	105
Downloading the System Update Package .....	105
Performing a System Update Using microSD Card.....	105
Performing a System Update Using ADB .....	105
Verifying System Update Installation.....	106
Enterprise Reset .....	106
Performing an Enterprise Reset From Device Settings.....	107
Downloading the Enterprise Reset Package .....	107
Performing an Enterprise Reset Using microSD Card .....	107
Performing an Enterprise Reset Using ADB.....	107
Performing a Factory Reset .....	108
Downloading the Factory Reset Package .....	108
Performing a Factory Reset Using microSD Card.....	108
Performing a Factory Reset Using ADB .....	109
Storage.....	110
Random Access Memory .....	110
Viewing Memory.....	110

## Table of Contents

Internal Storage .....	110
Viewing Internal Storage .....	110
External Storage .....	111
Viewing External Storage .....	111
Formatting a microSD Card .....	111
Formatting a microSD Card as Internal Memory.....	111
Enterprise Folder .....	111
Managing Apps .....	111
App Details .....	112
Managing Downloads.....	112
<b>Maintenance and Troubleshooting .....</b>	<b>113</b>
Introduction .....	113
Maintaining the Device.....	113
Battery Safety Guidelines.....	113
Cleaning Instructions.....	114
Approved Cleanser Active Ingredients .....	114
Harmful Ingredients .....	115
Device Cleaning Instructions .....	115
Special Cleaning Notes .....	115
Cleaning Materials Required .....	115
Cleaning Frequency .....	115
Cleaning Battery Connectors.....	116
Troubleshooting .....	117
Resetting the Device .....	117
Performing a Soft Reset.....	117
Performing a Hard Reset .....	117
Charge Only Cradle.....	118
Communication and Charging Cradles.....	118
Expansion Backs .....	119
4-Slot Charge Only Cradle .....	120
Charging Adapter .....	120
4-Slot Battery Charger.....	121
<b>Specifications .....</b>	<b>122</b>
Technical Specifications.....	122
SE4750 Expansion Back Decode Range.....	122
Integrated Scanner Decode Zones .....	123
Accessory Specifications .....	123
Charge Only Cradle.....	123
Communication and Charging Cradle .....	124

## Table of Contents

Rugged Communication and Charging Cradle .....	124
Expansion Backs .....	125

# About This Guide

This guide provides information about setting up and using the ET51 and ET56 tables with the Android™ 10 operating system. Some screens shown in this guide may differ from the actual screens shown on the device.

## Configurations

This guide covers the following configurations:

**Table 1** Configurations

Configuration	Operating System	Radios	Display	Memory	Data Capture
ET51CE	Android 10	WLAN: 802.11a/b/g/n/ac/d/h/i/k/r WPAN: Bluetooth	8.4 in. color	4 GB RAM/ 32 GB Flash	Camera, SE4750 Expansion Back, Ring Scanners. Bluetooth Scanners, and USB Scanners.
ET51CE with Integrated Scanner	Android 10	WLAN: 802.11a/b/g/n/ac/d/h/i/k/r WPAN: Bluetooth	8.4 in. color	4 GB RAM/ 32 GB Flash	Camera, integrated scanner, Ring Scanners. Bluetooth Scanners, and USB Scanners.
ET51CT	Android 10	WLAN: 802.11a/b/g/n/ac/d/h/i/k/r WPAN: Bluetooth	10.1" color	4 GB RAM/ 32 GB Flash	Camera, SE4750 Expansion Back, Ring Scanners. Bluetooth Scanners, and USB Scanners.

**Table 1** Configurations (Continued)

Configuration	Operating System	Radios	Display	Memory	Data Capture
ET56DE	Android 10	WLAN: 802.11a/b/g/n/ac/d/h/i/k/r WPAN: Bluetooth WWAN: LTE	8.4 in. color	4 GB RAM/ 32 GB Flash	Camera, SE4750 Expansion Back, Ring Scanners. Bluetooth Scanners, and USB Scanners.
ET56DT	Android 10	WLAN: 802.11a/b/g/n/ac/d/h/i/k/r WPAN: Bluetooth WWAN: LTE	10.1 in. color	4 GB RAM/ 32 GB Flash	Camera, SE4750 Expansion Back, Ring Scanners. Bluetooth Scanners, and USB Scanners.
ET56ET	Android 10	WLAN: 802.11a/b/g/n/ac/d/h/i/k/r WPAN: Bluetooth WWAN: LTE	10.1 in. color	4 GB RAM/ 32 GB Flash	Camera, SE4750 Expansion Back, Ring Scanners. Bluetooth Scanners, and USB Scanners.

## Related Documents and Software

The following documents provide more information about the tablet.

- ET51/56 Enterprise Tablet Quick Reference Guide, p/n MN-003332-xx
- ET51 Enterprise Tablet with Integrated Scanner Quick Reference Guide, p/n MN-003777-xx.

For the latest version of this guide and all guides, go to: [zebra.com/support](http://zebra.com/support).

## Notational Conventions

Notational conventions are used to highlight important information.

- **Bold** text is used to highlight the following:
  - Dialog box, window and screen names
  - Drop-down list and list box names
  - Check box and radio button names
  - Icons on a screen
  - Key names on a keypad
  - Button names on a screen
- Bullets (•) indicate:
  - Action items
  - Lists of alternatives
  - Lists of required steps that are not necessarily sequential.
- Sequential lists (for example, those that describe step-by-step procedures) appear as numbered lists.

## Icon Conventions

The following icons are used throughout the document. The icons and their associated meanings are described below.



**NOTE:** The text here indicates information that is supplemental for the user to know and that is not required to complete a task.



**IMPORTANT:** The text here indicates information that is important for the user to know.



**CAUTION:** If the precaution is not heeded, the user could receive minor or moderate injury.



**WARNING:** If danger is not avoided, the user CAN be seriously injured or killed.



**DANGER:** If danger is not avoided, the user WILL be seriously injured or killed.

## Service Information

If you have a problem with your equipment, contact Customer Support for your region. Contact information is available at: [zebra.com/support](http://zebra.com/support).

When contacting support, please have the following information available:

- Serial number of the unit (found on manufacturing label)
- Model number or product name (found on manufacturing label)
- Software type and version number
- IMEI number

Customer Support responds to calls by email or telephone within the time limits set forth in support agreements.

If the problem cannot be solved by Customer Support, the user may need to return the equipment for servicing and will be given specific directions. We are not responsible for any damages incurred during shipment if the approved shipping container is not used. Shipping the units improperly can possibly void the warranty. If applicable, remove the SIM card and/or microSD card from the device before shipping for service.

If the device was purchased from a business partner, contact that business partner for support.

## Determining Software Versions

Before contacting Customer Support, determine the current software version on your device.

1. Swipe down from the Status bar with two fingers to open the Quick Access panel, and then touch .
2. Touch **About phone**.
3. Scroll to view the following information:
  - **Battery information**
  - **Emergency information**
  - **SW components**

- **Legal information**
- **Model & hardware**
- **Android version**
  - **Android security patch level**
  - **Android security patch version**
  - **Baseband version**
  - **Kernel version**
  - **Build number**

To determine the device IMEI information (WWAN only), touch **About phone > IMEI**.

- **IMEI** - Displays the IMEI number for the device.
- **IMEI SV** - Displays the IMEI SV number for the device.

## Determining the Serial Number

Before contacting Customer Support, determine the serial number of your device.

1. Swipe down from the Status bar with two fingers to open the Quick Access panel, and then touch .
2. Touch **About phone > Model & hardware > Serial number**.

# Getting Started

## Introduction

This chapter explains how to set the device up for the first time.

## Unpacking

Carefully remove all protective material from around the tablet and save the shipping container for later storage and shipping.

Verify that you received all equipment listed below:

- Tablet with lithium-ion battery
- Quick Reference Guide
- Additional hand strap screws (ET51 Enterprise Tablet with integrated Scanner only).
- Cradle caps (ET51 Enterprise Tablet with integrated Scanner only).

Inspect the equipment for damage. If you are missing any equipment or if you find any damaged equipment, contact the Zebra Support Center immediately. See [Service Information on page 14](#) for contact information.



## ET51/56 Features

Figure 1 ET51/ET56 Front View

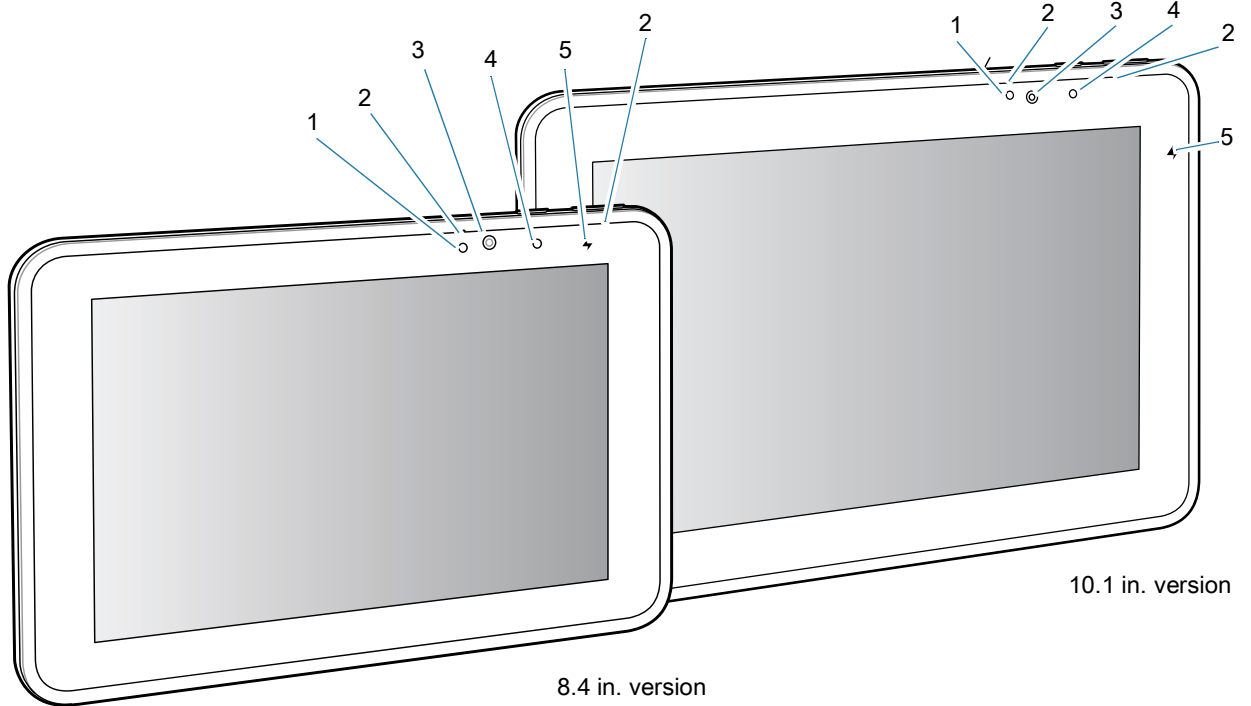
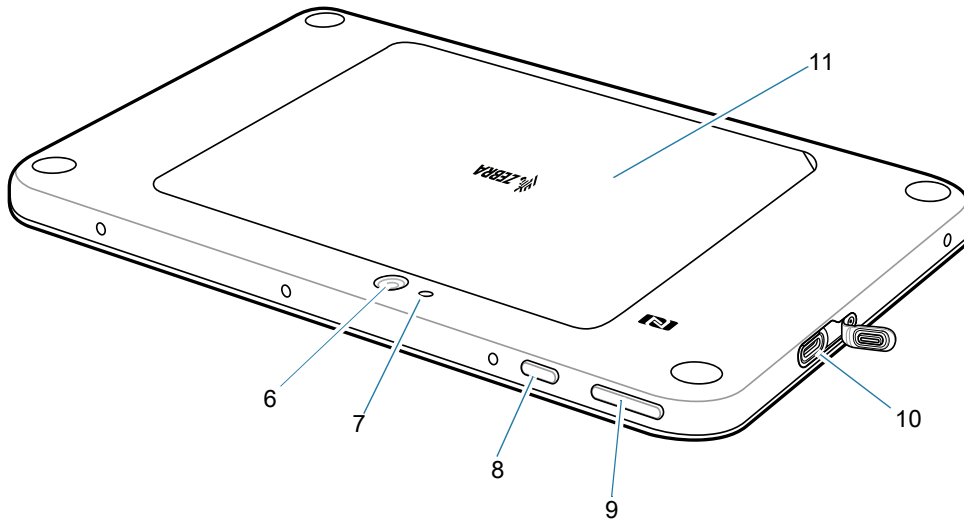

Table 2 ET51/ET56 Front View

Item	Description
1	Ambient Light Sensor - Recognizes the ambient light and adjusts the display brightness (if enabled).
2	Dual Front-Facing Microphones - Use for voice communications for audio recordings.
3	Front Facing Camera - Use for video conferencing or capturing images and video.
4	Notification LED - Lights blue when an application sends a notification.
5	Charging Indicator LED - Indicates charging status. <ul style="list-style-type: none"> <li>• Off - device is not connected to charger.</li> <li>• Blinking Amber - device is charging.</li> <li>• Green - device is connected and fully charged.</li> <li>• Red - charge error.</li> </ul>

**Figure 2** ET51/ET56 Back View



**Table 3** ET51/ET56 Back View

Item	Description
6	Rear Camera - Auto-focus camera for capturing high resolution images and video.
7	Camera LED Flash - Provides illumination for the camera.
8	Power Button - Push once to start the device; push it again to enable sleep mode. Push and hold it to shut down the tablet.
9	Volume Key - Push the left side to reduce the volume. Press the right side to increase the volume.
10	USB-C / Display - Provides communications with a host computer using a USB-C cable or a video monitor using a third-party adapter.
11	Battery Cover - Covers the replaceable battery.

**Figure 3** ET51/ET56 Bottom View

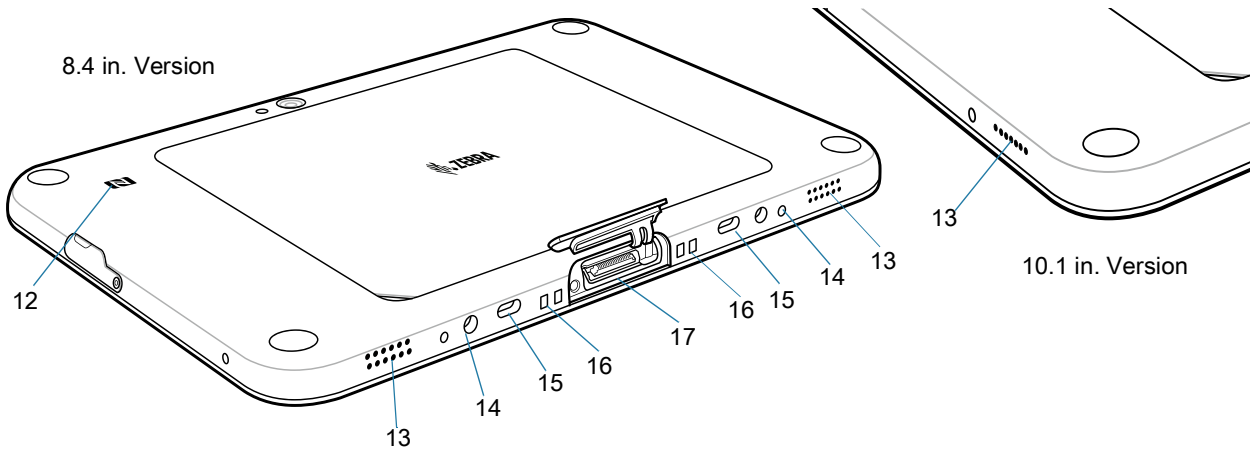
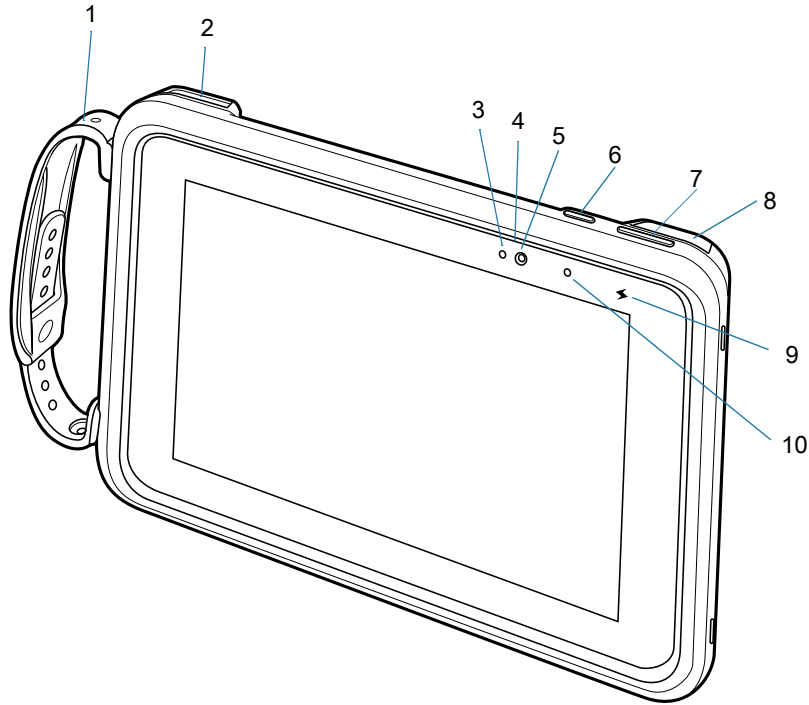

**Table 4** Bottom View

Item	Description
12	NFC Antenna Position - Use to read NFC cards.
13	Stereo Speakers - Provides audio playback.
14	Alignment Holes - Use to align tablet with cradle
15	Latching Slots - Insertion point for Communication and Charging cradle locks.
16	Charging Pins - Contact point for cradle charging.
17	Docking Connector - Interfaces with the cradle.

## ET51 with Integrated Scanner Features

**Figure 4** ET51 with Integrated Scanner Front View



**Table 5** ET51 with Integrated Scanner Front View

Item	Description
1	Adjustable Hand Strap - Use to securely hold the device in your hand.
2	Exit Window - Provides data capture using the imager.
3	Ambient Light Sensor - Recognizes the ambient light and adjusts the display brightness (if enabled).
4	Dual Front-Facing Microphones - Use for voice communications for audio recordings.
5	Front Facing Camera - Use for video conferencing or capturing images and video.
6	Power Button - Push once to start the device; push it again to enable sleep mode. Push and hold it to shut down the device.
7	Volume Key - Press the left side to reduce the volume. Press the right side to increase the volume.
8	USB-C Port - Use to charge the device using a USB-C cable and power supply.
9	Charging Indicator LED - Indicates charging status. <ul style="list-style-type: none"> <li>• Off - device is not connected to charger.</li> <li>• Blinking Amber - device is charging.</li> <li>• Green - device is connected and fully charged.</li> <li>• Red - charge error.</li> </ul>
10	Notification LED - Lights blue when an application sends a notification.

**Figure 5** ET51 with Integrated Scanner Back View

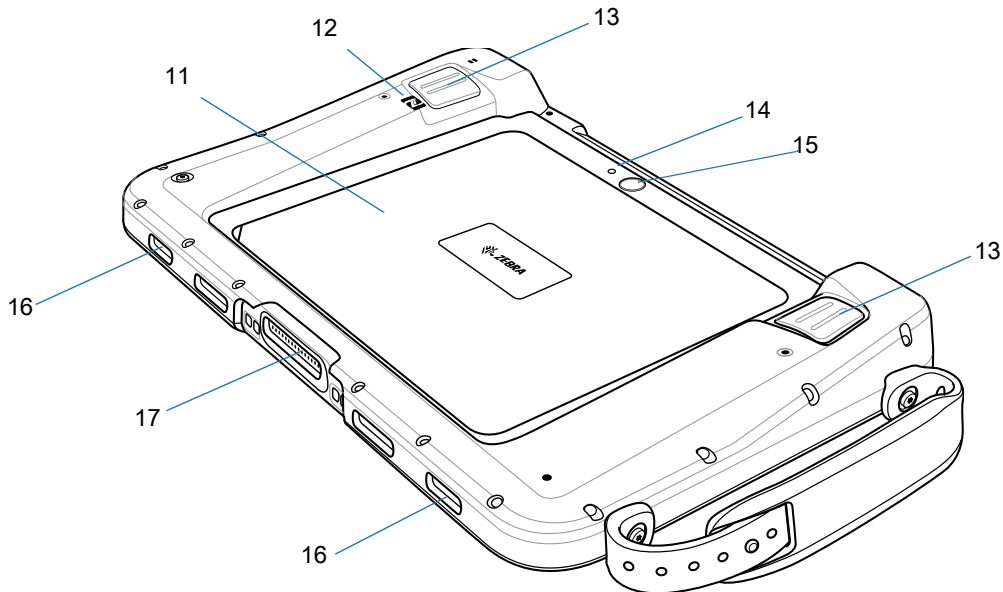

**Table 6** ET51 with Integrator Scanner Back View

Item	Description
11	Back Cover - Covers the replaceable battery.
12	NFC Antenna Position - Use to read NFC cards.
13	Scan Button - Initiates barcode data capture when a scan-enabled application is active.
14	Rear Camera - Use for high resolution images and video.
15	Camera LED Flash - Provides illumination for the camera.
16	Stereo Speakers - Provides audio playback.
17	Docking Connector - Interfaces with the cradle.

## Getting Started

In order to start using the device for the first time:

- Install microSD card
- Install nano SIM Card (ET56 only)
- Charge the device
- Perform basic configuration.

### Installing a microSD Card

To install a microSD card:

1. Press and hold the Power button until the menu appears.
2. Touch **Power off**.
3. Lift the notched corner of the battery cover and carefully lift the battery cover off the device.

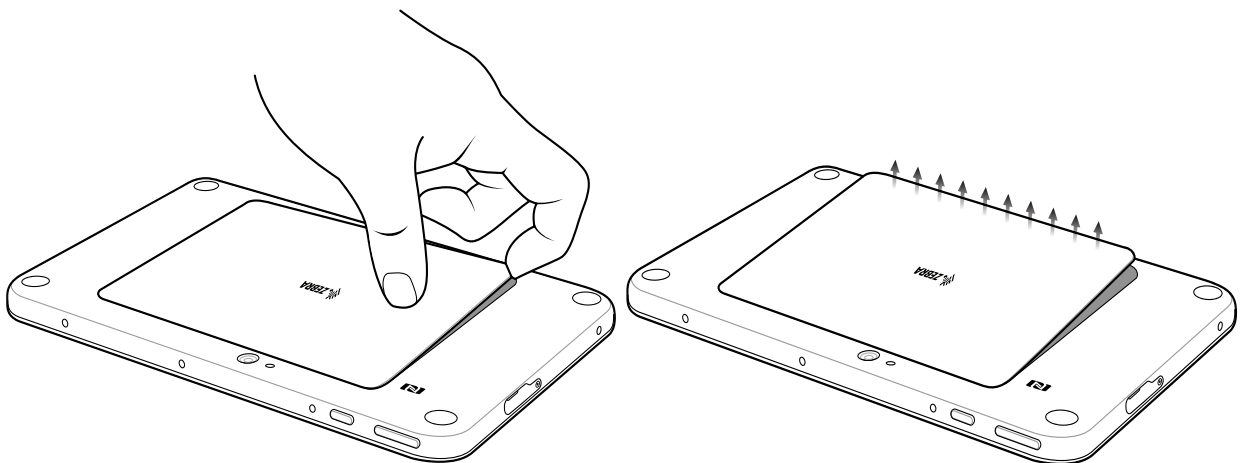

4. On the 8.4 in. version, push the two locking tabs up, then pull up on the tab to remove battery.  
On the 10.1 in. version, push the two locking tabs up (1), then lift the battery up (2).

**Figure 6** Removing the Battery - 8.4 in.

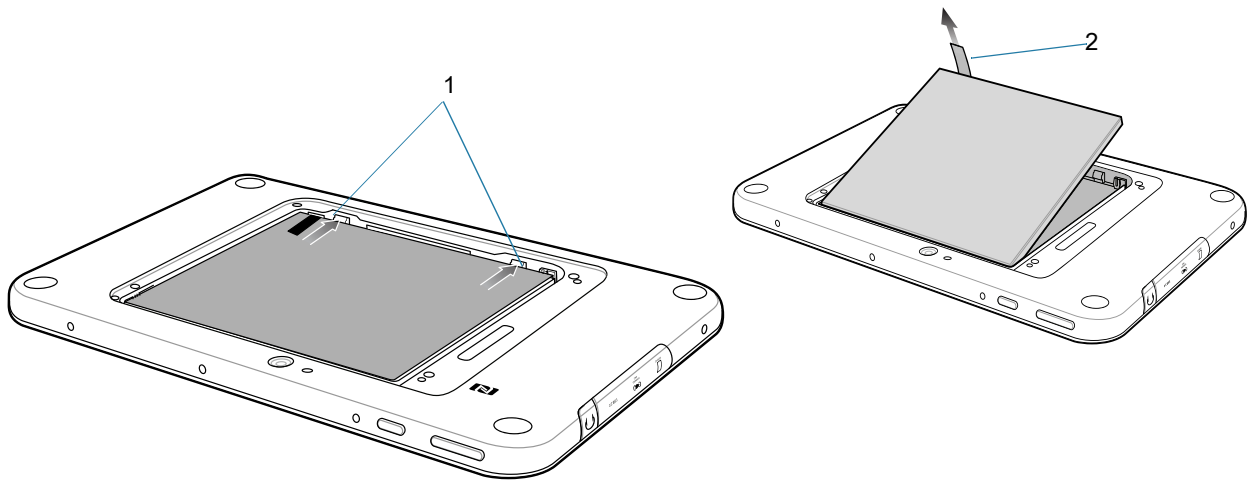

1	Locking tabs
2	Pull tabs

**Figure 7** Removing the Battery - 10.1 in.

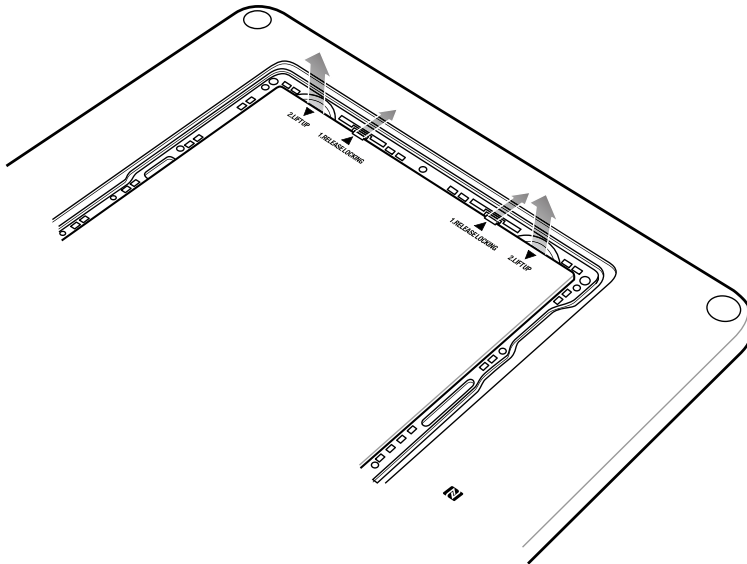

### Install the microSD Card

1. Insert the microSD card with contacts facing down; 8.4 in. version shown here.

**Figure 8** Inserting microSD Card

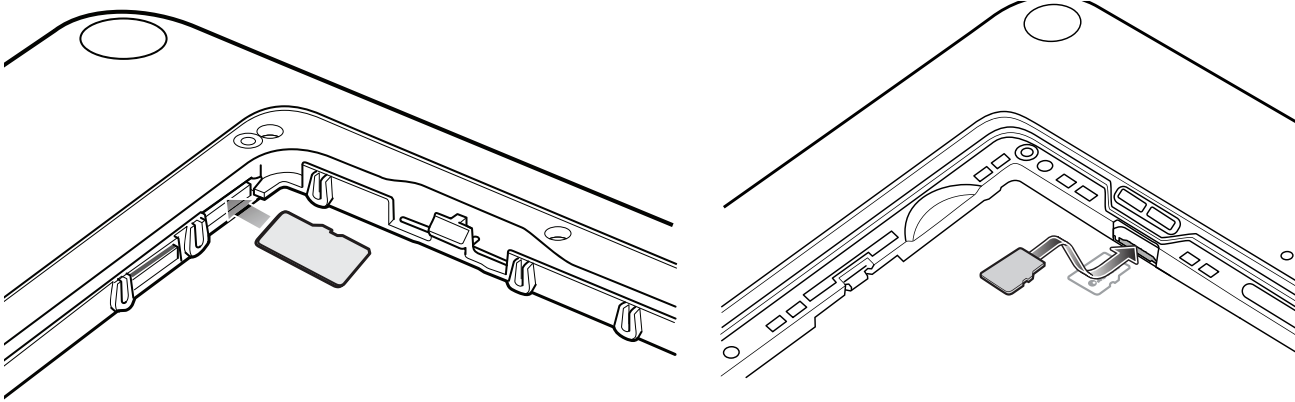

8.4 in. Version

10.1 in. Version

2. Push the micro SD card in and ensure that it locks into place.

### Install the nano SIM Card



**NOTE:** ET56 only.

To install the nano SIM card:

1. Insert the nano SIM card with contacts facing down.

**Figure 9** Inserting the nano SIM Card - 8.4 in.

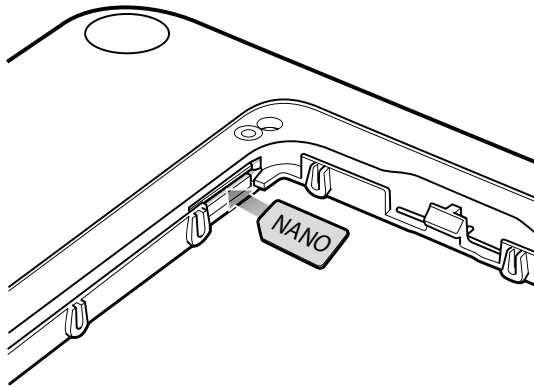

**Figure 10** Inserting the nano SIM Card - 10.1 in.

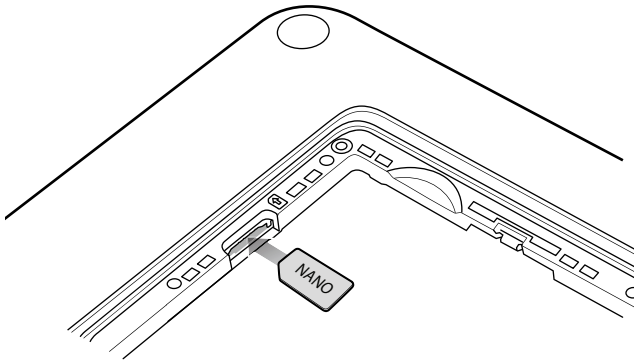

2. Push the SIM card in and ensure that it locks into place.
3. Replace the battery.
4. Press the battery down to ensure the two battery latches engage.

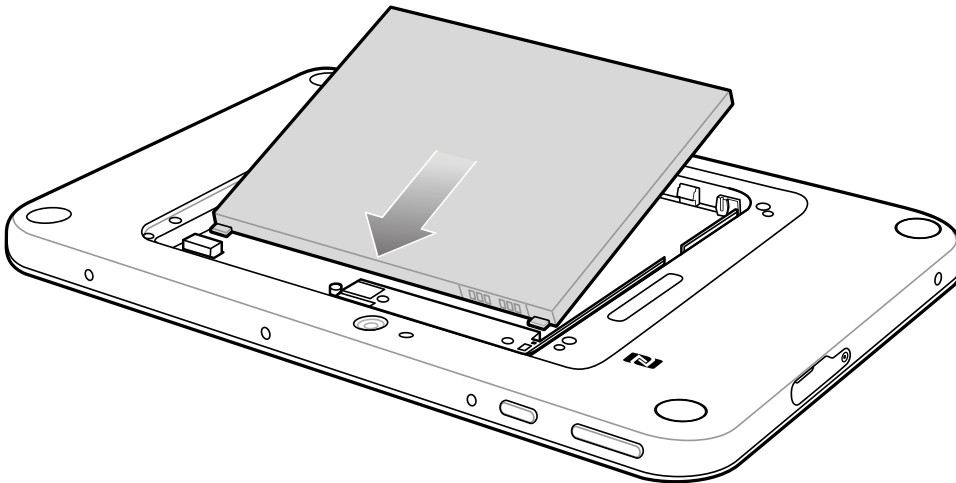

**CAUTION:** Be aware of the orientation of the battery cover. Failure to replace the battery cover properly may damage the battery cover.

5. Align the tabs on the underside of the cover with the slot around the battery well. Make sure that the notch on the battery cover is at the bottom left corner of the device.



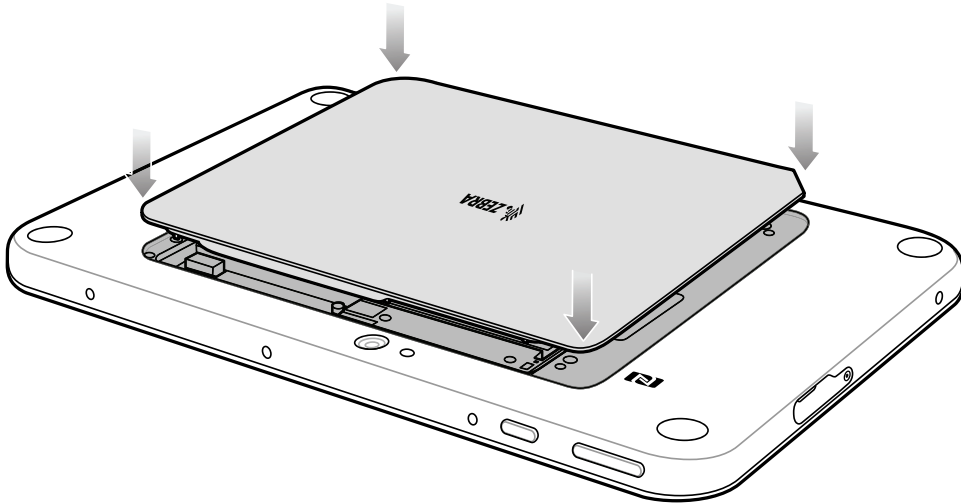

6. Carefully press down around the edge of the cover. Make sure that the cover is seated properly.

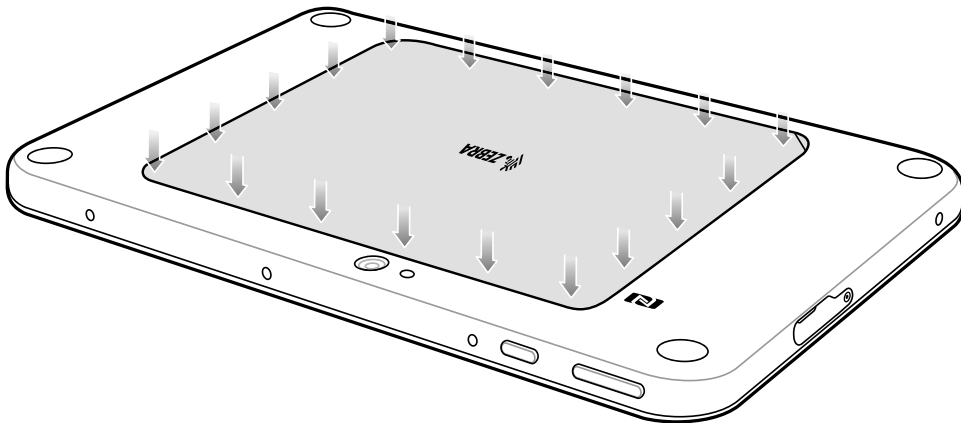

7. Press Power button to turn on the device.

## Charging the Battery

Use one of the cradles to charge the main battery installed in the device. See the [Accessories](#) for charging accessories.

The 8.4 in. tablet main battery charges from fully depleted to 90% in approximately 2.5 hours and from fully depleted to 100% in approximately 3.5 hours.

The 10.1 in. tablet main battery charges from fully depleted to 90% in approximately three hours and from fully depleted to 100% in approximately four hours.



**NOTE:** The Charging indicator only illuminates when the tablet is connected to AC power.

## Google Account Setup



**NOTE:** The device has to be connected to the internet in order to set up a Google™ account. A Google account is only required on devices with GMS software.

The first time the device starts, the Setup Wizard displays. Follow the on-screen instructions to set up a Google account, configure Google Pay™ for purchasing items from the Google Play™ store, to enter your personal information, and enable backup/restore features.

## Turning Off the Tablet



**NOTE:** After the device is powered off and external power is applied to the device, the device will automatically power on. This includes powered cradles, Expansion Back with Power Pack, Rugged Charge Connector, and power supply/USB-C cable.

To turn off the device:

1. Press and hold the power button until the menu appears.
2. Touch **Power off**.

## Replacing the SIM Card



**NOTE:** ET56 only.



**CAUTION:** To avoid damage to the SIM slot, do not pull the SIM card out of the SIM slot. Push the SIM card in to eject it.

To replace the SIM card:

1. Press and hold the Power button until the menu appears.
2. Touch **Power off**.
3. Lift the notched corner of the battery cover and carefully lift the battery cover off the device.
4. On the 8.4 in. version, push the two locking tabs up, then pull up on the tab to remove battery.  
On the 10.1 in. version, push the two locking tabs up, then lift the battery up.
5. Push in the SIM card and release. The card eject slightly.
6. Remove the SIM card from the card slot. The card should easily slide out. If not, the SIM card was not ejected correctly. Repeat step 5.

7. Replace the battery.
8. Press the battery down to ensure the two battery latches engage.
9. Replace the battery cover.

## Replacing the microSD Card



**CAUTION:** To avoid damage to the microSD card slot, do not pull the microSD card out of the microSD Card slot. Push the microSD card in to eject it.

To replace the microSD card:

1. Press and hold the Power button until the menu appears.
2. Touch **Power off**.
3. Lift the notched corner of the battery cover and carefully lift the battery cover off the device.
4. On the 8.4 in. version, push the two locking tabs up, then pull up on the tab to remove battery.  
On the 10.1 in. version, push the two locking tabs up, then lift the battery up.
5. Push in the SIM card and release. The card eject slightly.
6. Remove the microSD card from the card slot. The card should easily slide out. If not, the microSD card was not ejected correctly. Repeat step 5.
7. Insert the replacement microSD card with contacts facing down.
8. Push the microSD card in and ensure that it locks into place.
9. Replace the battery.
10. Press the battery down to ensure the two battery latches engage.
11. Replace the battery cover.

## Interactive Sensor Technology

The device contains sensors that monitor movement, orientation and ambient light:

- Gyroscope - Measures angular rotational velocity to detect rotation of the device.
- Accelerometer - Measures the linear acceleration of movement to detect the orientation of the device.
- Digital Compass - The digital compass or magnetometer provides simple orientation in relation to the Earth's magnetic field. As a result, the device always knows which way is North so it can auto rotate digital maps depending on the physical orientation of the device.
- Light Sensor - Detects ambient light and adjusts the screen brightness.

In order to take advantage of these sensors, applications use API commands. Refer to the Zebra Android EMDK for more information.

## Turning Off the Display

To turn off the display press and release the power button.

# Using the Device

## Home Screen

Turn on the device to display the Home screen. Depending on how your system administrator configured your device, your Home screen may appear differently than the graphics in this section.

After a suspend or screen time-out, the Home screen displays with the lock slider. Touch the screen and slide up to unlock.

The Home screen provides four additional screens to place widgets and shortcuts. Swipe the screen left or right to view the additional screens.



**NOTE:** By default, AOSP devices do not have the same icons on the Home screen as GMS devices. Icons are shown below for example only.

Home screen icons can be configured by the user and may look different than shown.

**Figure 11** Home Screen (ET56 Shown)

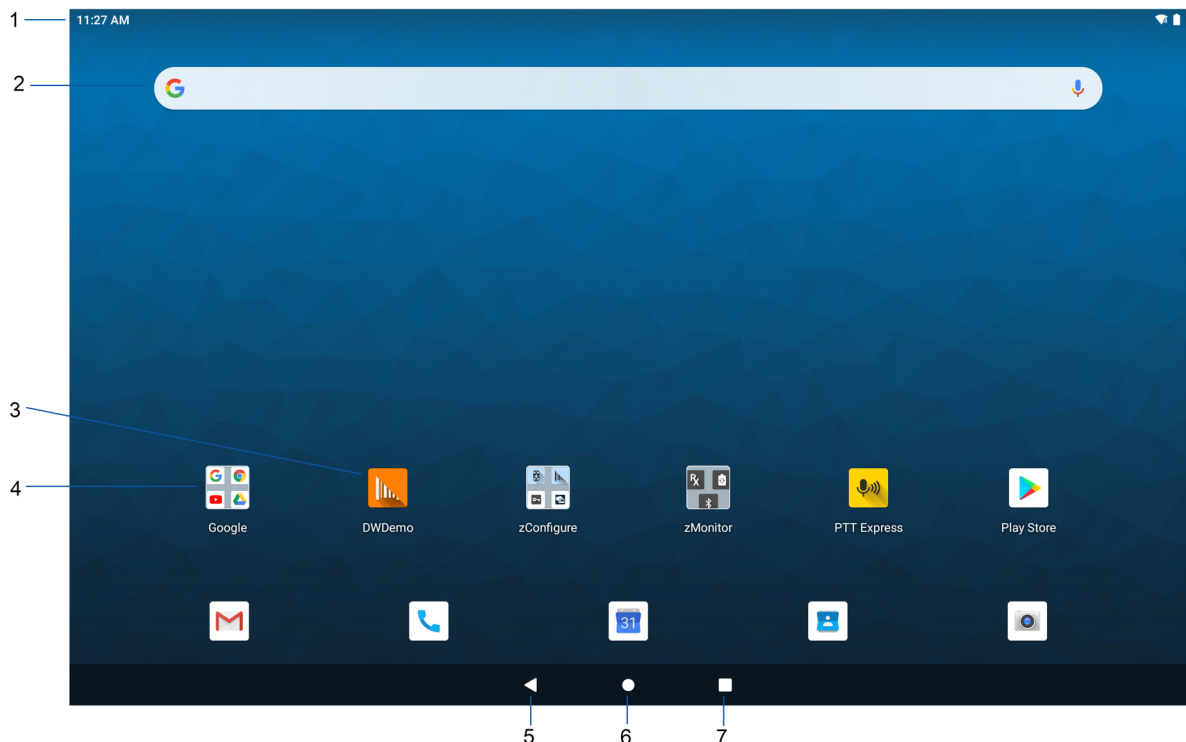

1	Status Bar	Displays the time, status icons (right side), and notification icons (left side). For more information see <a href="#">Notification Icons on page 30</a> and <a href="#">Managing Notifications on page 32</a> .
2	Widgets	Launches stand-alone apps that run on the Home screen.
3	Shortcut Icons	Opens apps installed on the device.
4	Folder	Contains apps.
5	Back	Displays the previous screen.
6	Home	Displays the Home screen.
7	Recent	Displays recently used applications.

## Setting Home Screen Rotation

By default, the Home screen rotation is disabled.

1. Touch and hold anywhere on the Home screen until the options appear.
2. Touch **Home settings**.
3. Touch the **Allow Home screen rotation** switch.
4. Touch the Home button.
5. Rotate the device.

## Status Bar

The Status bar displays the time, notification icons (left side), and status icons (right side).

If there are more notifications than can fit in the Status bar, a dot displays indicating that more notifications exist. Swipe down from the Status bar to open the Notification panel and view all notifications and status.

**Figure 12** Notification and Status Icons





















1	Notification Icons. See <a href="#">Notification Icons on page 30</a> .
2	Status Icons. See <a href="#">Status Icons on page 31</a> .

## Notification Icons

Notification icons indicate app events and messages.





















**Table 7** Notification Icons

Icon	Description
	Main battery is low.
	More notifications are available for viewing.
	Data is syncing.
	Indicates an upcoming event. AOSP devices only.
	Indicates an upcoming event. GMS devices only.
	Open Wi-Fi network is available.
	Audio is playing.
	Problem with sign-in or sync has occurred.
	Device is uploading data.
	Animated: the device is downloading data. Static: the download is complete.
	Device is connected to or disconnected from a virtual private network (VPN).
	Preparing internal storage by checking it for errors.
	USB debugging is enabled on the device.
	Wired headset with a boom module is connected to the device.
	Wired headset without a boom module is connected to the device.
	PTT Express Voice client status. See the PTT Express PTT Notification Icons for a complete list.
	Indicates the RxLogger app is running.
	Indicates the Bluetooth scanner is connected to the device.
	Indicates the ring scanner is connected to the device in HID mode.

## Status Icons



Status icons display system information for the device.

**Table 8** Status Icons

Icon	Description
	Alarm is active.
	Main battery is fully charged.
	Main battery is partially drained.
	Main battery charge is low.
	Main battery charge is very low.
	Main battery is charging.
	All sounds, except media and alarms, are muted. Vibrate mode is active.
	Do Not Disturb mode active.
	Airplane Mode is active. All radios are turned off.
	Bluetooth is on.
	The device is connected to a Bluetooth device.
	Connected to a Wi-Fi network. Indicates the Wi-Fi version number.
	Not connected to a Wi-Fi network or no Wi-Fi signal.
	Connected to an Ethernet network.
	Speakerphone enabled.
	Portable Wi-Fi hotspot is active (WWAN only).
	Connected to a 4G LTE/LTE-CA network (WWAN only) <sup>1</sup> .
	Connected to a DC-HSPA, HSDPA, HSPA+, HSUPA, LTE/LTE-CA or WCDMA network (WWAN only) <sup>1</sup> .
	Connected to a WCDMA network (WWAN only) <sup>1</sup> .
	Connected to a DC - HSPA, HSDPA, HSPA+ or HSUPA network (WWAN only) <sup>1</sup> .
	Connected to an EDGE network (WWAN only) <sup>1</sup> .

<sup>1</sup>Cellular network icon that appears is dependent upon the carrier/network.

**Table 8** Status Icons (Continued)

Icon	Description
	Connected to a GPRS network (WWAN only) <sup>1</sup> .
	Roaming from a network (WWAN only).
	No SIM card installed (WWAN only).
<sup>1</sup> Cellular network icon that appears is dependent upon the carrier/network.	

## Managing Notifications

Notification icons report the arrival of new messages, calendar events, alarms, and ongoing events. When a notification occurs, an icon appears in the Status bar with a brief description. See [Notification Icons on page 30](#) for a list of possible notification icons and their description.

- To view a list of all notifications, open the Notification panel by dragging the Status bar down from the top of the screen.

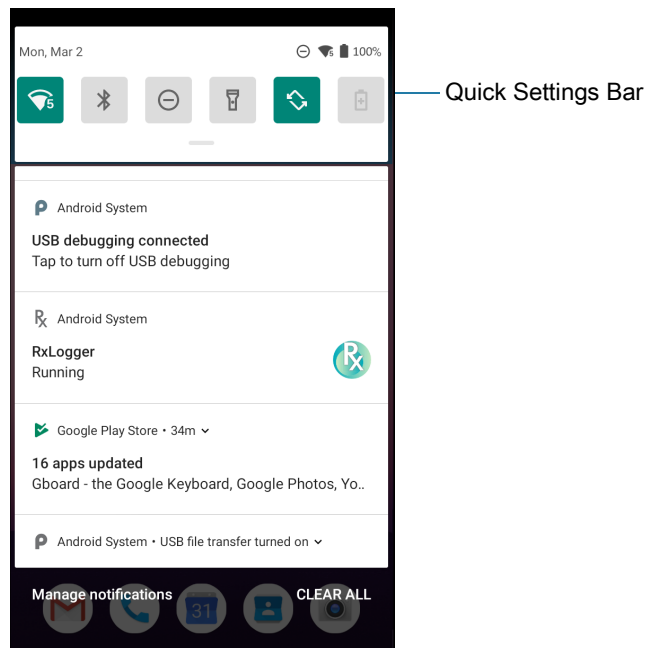
**Figure 13** Notification Panel

- To respond to a notification, open the Notification panel and then touch a notification. The Notification panel closes and the corresponding app opens.
- To manage recent or frequently used notifications, open the Notification panel and then touch **Manage notifications**. Touch the toggle switch next to an app to turn off all notifications, or touch an app for more notification options.
- To clear all notifications, open the Notification panel and then touch **CLEAR ALL**. All event-based notifications are removed. Ongoing notifications remain in the list.
- To close the Notification panel, swipe the Notification panel up.



## Opening the Quick Access Panel

Use the Quick Access panel to access frequently used settings (for example, Airplane mode). To get to the Quick Access Panel:

- If the device is locked, swipe down once.
- If the device is unlocked, swipe down once with two fingers, or twice with one finger.
- If the Notification panel is open, swipe down from the Quick Settings bar.

**Figure 14** Quick Access Panel

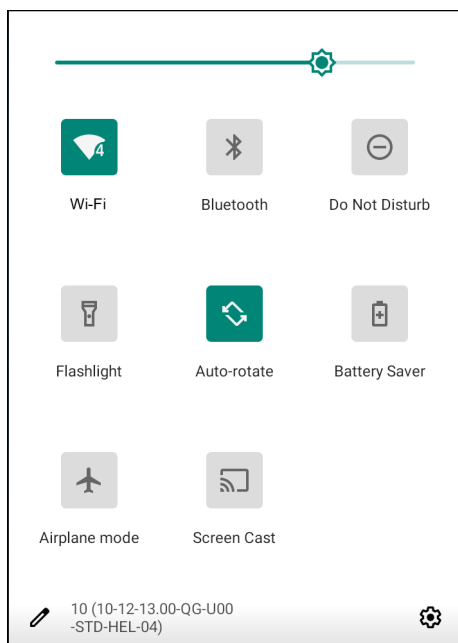

**NOTE:** Not all icons are pictured. Icons may vary.

### Quick Access Panel Icons

- Display brightness - Use the slider to decrease or increase the brightness of the screen.
- Wi-Fi network - Turn Wi-Fi on or off. To open Wi-Fi settings, touch the Wi-Fi network name.
- Bluetooth settings - Turn Bluetooth on or off. To open Bluetooth settings, touch **Bluetooth**.
- Battery saver - Turn Battery saver mode on or off. When Battery saver mode is on the performance of the device is reduced to preserve battery power.
- Invert colors - Invert the display colors.
- Do not disturb - Control how and when to receive notifications.
- Mobile data - Turns cellular radio on or off. To open Mobile data settings, touch and hold (WWAN only).
- Airplane mode - Turn Airplane mode on or off. When Airplane mode is on the device does not connect to Wi-Fi or Bluetooth.
- Auto-rotate - Lock the device's orientation in portrait or landscape mode or set to automatically rotate.
- Flashlight - Turn flashlight on or off. Turn camera flash on or off.

- Location - Enable or disable locationing feature.
- Hotspot - Turn on to share the device's mobile data connection with other devices.
- Data Saver - Turn on to prevent some apps from sending or receiving data in the background.
- Night Light - Tint the screen amber to make it easier to look at the screen in dim light. Set Night Light to turn on automatically from sunset to sunrise, or at other times.
- Screen Cast - Share phone content on Chromecast or a television with Google Cast built-in. Touch cast screen to display a list of devices, then touch a device to begin casting.
- Dark Theme - Toggles dark theme on and off. Dark themes reduce the luminance emitted by the screen, while meeting minimum color contrast ratios. It helps improve visual ergonomics by reducing eye strain, adjusting brightness to current lighting conditions, and facilitating screen use in dark environments, while conserving battery power.
- Focus mode - Turn on to pause distracting apps. To open Focus mode settings, touch and hold.
- Bedtime mode - Turn grayscale on and off. Grayscale turns the screen black and white, reducing phone distractions and improving battery life.
- Nearby Share - Helps find and interact with services and devices close to the device.

### Editing Icons on the Quick Settings Bar

The first several setting tiles from the Quick Access panel become the Quick Settings bar.

Open the Quick Access panel and touch  to edit, add, or remove settings tiles.

## Battery Management

Observe the recommended battery optimization tips for your device.

- Set the screen to turn off after a short period of non-use.
- Reduce screen brightness.
- Turn off all wireless radios when not in use.
- Turn off automatic syncing for Email, Calendar, Contacts, and other apps.
- Minimize use of apps that keep the device from suspending, for example, music and video apps.



**NOTE:** Before checking the battery charge level, remove the device from any AC power source (cradle or cable).

### Checking Battery Status

- Open **Settings** and touch **About phone** > **Battery Information**.

Or, swipe up from the bottom of the screen and touch  to open the **Battery Manager** app. See [Battery Manager on page 4](#).

- **Battery present status** indicates if the battery is present.
- **Battery level** lists the battery charge (as a percentage of fully charged).
- Swipe down with two fingers from the status bar to open the quick access panel.
  - Battery percentage is displayed next to the battery icon.

## Monitoring Battery Usage

The **Battery** screen provides battery charge details and power management options to extend battery life.

1. Go to **Settings**.
2. Touch **Battery**.

Display battery information and power management options for a specific app.

1. Go to **Settings**.
2. Touch **Apps & notifications**.
3. Touch an app.
4. Touch **Advanced > Battery**.

Different apps display different information. Some apps include buttons that open screens with settings to adjust power use. Use the **DISABLE** or **FORCE STOP** buttons to turn off apps that consume too much power.

## Low Battery Notification

When the battery charge level drops below 18%, the device displays a notice to connect the device to power. The user should charge the battery using one of the charging accessories.

When the battery charge drops below 10%, the device displays a notice to connect the device to power. The user must charge the battery using one of the charging accessories.

When the battery charge drops below 4%, the device turns off. The user must charge the battery using one of the charging accessories.

## Interactive Sensor Technology

The device contains sensors that monitor movement, orientation and ambient light.

- Gyroscope - Measures angular rotational velocity to detect rotation of the device.
- Accelerometer - Measures the linear acceleration of movement to detect the orientation of the device.
- Digital Compass - The digital compass or magnetometer provides simple orientation in relation to the Earth's magnetic field. As a result, the device always knows which way is North so it can auto rotate digital maps depending on the physical orientation of the device.
- Light Sensor - Detects ambient light and adjusts the screen brightness.

In order to take advantage of these sensors, applications use API commands. Refer to the Google Android Sensor APIs for more information. For information on the Zebra Android EMDK, go to: [techdocs.zebra.com](http://techdocs.zebra.com).

## Waking the Device

The device goes into Suspend mode when you press the Power button or after a period of inactivity (set in the Display settings window).

1. To wake the device from Suspend mode, press the Power button.  
The Lock screen displays.
2. Swipe the screen up to unlock.

- If the Pattern screen unlock feature is enabled, the Pattern screen appears instead of the Lock screen.
- If the PIN or Password screen unlock feature is enabled, enter the PIN or password after unlocking the screen.



**NOTE:** If you enter the PIN, password, or pattern incorrectly five times, you must wait 30 seconds before trying again.

If you forget the PIN, password, or pattern contact your system administrator.

## USB Communication

Connect the device to a host computer to transfer files between the device and the host computer.

When connecting the device to a host computer, follow the host computer's instructions for connecting and disconnecting USB devices, to avoid damaging or corrupting files. For information on USB communication accessories available for this device, see [Accessories](#).

### Transferring Files

Use Transfer files to copy files between the device and the host computer.

1. Connect the device to a host computer using a USB accessory.
2. On the device, pull down the Notification panel and touch **Charging this device via USB**.  
By default, **No data transfer** is selected.
3. Touch **File Transfer**.
4. On the host computer, open a file explorer application.
5. Locate the **device** as a portable device.
6. Open the **Internal storage** folder.
7. Copy files to and from the device or delete files as required.

### Transferring Photos

Use **PTP** to copy photos from the device to the host computer.

1. Connect the device to a host computer using a USB accessory.
2. On the device, pull down the Notification panel and touch **Charging this device via USB**.
3. Touch **PTP**.
4. On the host computer, open a file explorer application.
5. Open the **Internal storage** folder.
6. Copy or delete photos as required.

## Disconnect from the Host Computer



Carefully follow the host computer's instructions to disconnect USB devices correctly to avoid losing information.



To disconnect the device from the host computer:

1. On the host computer, unmount the device.
2. Remove the device from the USB accessory.

# Settings

## Accessing Settings

There are multiple ways to access settings on a device.

- Swipe down with two fingers from the top of the Home screen to open the Quick Access panel and touch .
- Double-swipe down from the top of the Home screen to open the Quick Access panel and touch .
- Swipe up from the bottom of the Home screen to open APPS and touch  **Settings**.

## Display Settings

Use Display settings to change the screen brightness, enable night light, change the background image, enable screen rotation, set sleep time, and change font size.

### Setting the Screen Brightness Manually

Manually set the screen brightness using the touchscreen.

1. Swipe down with two fingers from the Status bar to open the Quick Access panel.
2. Slide the icon to adjust the screen brightness level.

### Setting the Screen Brightness Automatically

Automatically adjust the screen brightness using the built-in light sensor.

1. Go to **Settings**.
2. Touch **Display**.
3. If disabled, touch **Adaptive brightness** to automatically adjust the brightness.  
By default, **Adaptive brightness** is enabled. Toggle the switch to disable.
4. Touch the Home button.

### Setting Night Light

The Night Light setting tints the screen amber, making the screen easier to look at in low light.

1. Go to **Settings**.
2. Touch **Display**.

3. Touch **Night Light**.
4. Touch **Schedule**.
5. Select one of the schedule values:
  - None (default)
  - Turns on at custom time
  - Turns on from sunset to sunrise.
6. By default, **Night Light** is disabled. Touch **TURN ON NOW** to enable.
7. Adjust the tint using the **Intensity** slider.
8. Touch the Home button.

## Setting Screen Rotation

By default, screen rotation is enabled.

1. Go to **Settings**.
2. Touch **Display > Advanced**.
3. Touch **Auto-rotate screen**.



**NOTE:** To change the Home screen rotation, see [Setting Home Screen Rotation on page 29](#).

4. Touch the Home button.

## Setting Screen Timeout

Set the screen sleep time.

1. Go to **Settings**.
2. Touch **Display > Advanced > Screen timeout**.
3. Select one of the sleep values.
  - **15 seconds**
  - **30 seconds**
  - **1 minute** (default)
  - **2 minutes**
  - **5 minutes**
  - **10 minutes**
  - **30 minutes**
4. Touch the Home button.

## Lock Screen Display

The lock screen display setting wakes the screen when notifications are received.

1. Go to **Settings**.
2. Touch **Display > Advanced**.

3. Touch **Lock screen display**.
4. In the **When to show** section, enable or disable an option using the switch.
5. Touch the Home button.

## Setting Font Size

Set the size of the font in system apps.

1. Go to **Settings**.
2. Touch **Display > Advanced**.
3. Touch **Font size**.
4. Select one of the font size values.
  - Small
  - Default
  - Large
  - Largest.
5. Touch the Home button.

## Touch Panel Mode

The device display is able to detect touches using a finger, a conductive-tip stylus, or gloved finger.



**NOTE:** A glove can be made of medical latex, leather, cotton, or wool. For optimal performance use a Zebra certified stylus.

1. Go to **Settings**.
2. Touch **Display > Advanced**.
3. Touch **Touch panel mode**.
4. Select:
  - **Finger Only Mode - Moisture optimized - Rain Mode** to use a finger on the screen and when the device may have water on the screen.
  - **Stylus and Finger** to use a finger or a stylus on the screen.
  - **Finger and Stylus** to use a finger or a stylus on the screen.
  - **Finger and Glove** to use a finger or a gloved finger on the screen.
  - **Glove and Finger** to use a finger or a gloved finger on the screen.
5. Touch the Home button.

## Setting the Date and Time

The date and time is automatically synchronized using an NITZ server when the device is connected to a wireless network. You are only required to set the time zone or set the date and time if the wireless LAN does not support Network Time Protocol (NTP) or when not connected to a wireless network.

1. Go to **Settings**.
2. Touch **System > Date & time**.





3. Touch **Use network-provided time** to disable automatic date and time synchronization.
4. Touch **Use network-provided time zone** to disable automatic time zone synchronization.
5. Touch **Update Interval**.
6. Select the interval time to synchronize your device time from the network.
7. Touch **Date**.
8. In the calendar, set today's date.
9. Touch **OK**.
10. Touch **Time**.
11. Touch the green circle, drag to the current hour and then release.
12. Touch the green circle, drag to the current minute and then release.
13. Touch **AM** or **PM**.
14. Touch **OK**.
15. Touch **Time zone**.
16. Select the current time zone from the list.
17. Touch **Use 24-hour format**.
18. Touch the Home button.

## General Sound Setting

Use the **Sound** settings to configure media and alarm volumes.

1. Go to **Settings**.
2. Touch **Sound**.
3. Touch an option to set sounds.

## Sound Options

- **Zebra volume controls**
  - **Ring volume** - Controls the ringtone volume.
  - **Media volume** - Controls the music, games, and media volume.
  - **Alarm volume** - Controls the alarm clock volume.
  - **Notifications volume** - Controls the notification volume.
  - **In call volume** - Controls the volume during a call.
  - **Scanner volume** - Controls the scanner volume.
- **Volume presets**
  -  - Mutes the ring, notifications, and scanner so that the device does not make sounds or vibrate.
  -  - All sounds except media and alarms are silenced and vibrate mode is active.
  -  - Enables all sounds at the user defined levels.
- **Do Not Disturb** - Mutes some or all sounds and vibrations.
- **Shortcut to prevent ringing** - Select how the shortcut method prevents ringing.

- **Default notification sound** - Select a sound to play for all system notifications.
- **Default alarm sound** - Select a sound to play for alarms.
- **Other sounds and vibrations**
  - **Screen locking sounds** - Play a sound when locking and unlocking the screen (default – enabled).
  - **Charging sounds and vibration** - Plays a sound and vibrates when power is applied to the device (default - enabled).
  - **Touch sounds** - Play a sound when making screen selections (default – enabled).
  - **Touch vibration** - Vibrate the device when making screen selections (default – disabled).
- **Wireless Emergency alerts** - Touch to configure emergency broadcast settings and notifications.

## Remapping a Button

Buttons on the device can be programmed to perform different functions or as shortcuts to installed apps. For a list of key names and descriptions, refer to: [techdocs.zebra.com](http://techdocs.zebra.com).

1. Go to **Settings**.
2. Touch **Key Programmer**. A list of programmable buttons displays.
3. Select the button to remap.
4. Touch the **BUTTON REMAPPING** tab or the **SHORTCUT** tab that lists the available functions and applications.
5. Touch a function or application shortcut to map to the button.



**NOTE:** If you select an application shortcut, the application icon appears next to the button on the Key Programmer screen.

6. Touch the Home button.

## Remappable Keys

**Figure 15** Key Positions

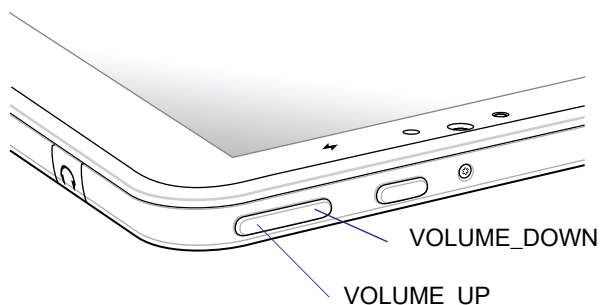

- **VOLUME\_DOWN** - Volume down button.
- **VOLUME\_UP** - Volume up button.

## Keyboards

The device provides multiple keyboard options.

- Enterprise Keyboard





**NOTE:** By default the Enterprise and Virtual Keyboards are disabled.

## Keyboard Configuration

### Enabling Keyboards

1. Go to **Settings**.
2. Touch **System > Languages & input > Virtual keyboard > Manage keyboards**.
3. Touch a keyboard to enable.

### Switching Between Keyboards

- To switch between keyboards, touch in a text box to display the current keyboard.
  - On the Gboard keyboard, touch and hold  (GMS devices only).
  - On the Android keyboard, touch and hold  (AOSP devices only).
  - On the Enterprise keyboard, touch . Only available with Mobility DNA Enterprise License. Not pre-installed on the device. Contact Zebra Support for more information.

## Using the Android and Gboard Keyboards

Use the Android or Gboard keyboards to enter text in a text field.

To configure the keyboard settings, touch and hold **,** (comma) and then select **Android keyboard settings**.

### Edit Text

Edit entered text and use menu commands to cut, copy, and paste text within or across apps. Some apps do not support editing some or all of the text they display; others may offer their own way to select text.

### Entering Numbers, Symbols, and Special Characters

1. Enter numbers and symbols.
  - Touch and hold one of the top-row keys until a menu appears then select a number or special character.
  - Touch the Shift key once for a single capital letter. Touch the Shift key twice to lock in uppercase. Touch the Shift key a third time to unlock Capslock.
  - Touch **?123** to switch to the numbers and symbols keyboard.
  - Touch the **=\<** key on the numbers and symbols keyboard to view additional symbols.
2. Enter special characters.
  - Touch and hold a number or symbol key to open a menu of additional symbols. A larger version of the key displays briefly over the keyboard.

## Using the Enterprise Keyboard

The Enterprise Keyboard contains multiple keyboard types.

- Numeric
- Alpha

- Special characters
- Data capture.

### Numeric Tab

The numeric keyboard is labeled **123**. The keys displayed vary on the app being used. For example, an arrow displays in **Contacts**, however **Done** displays in **Email** account setup.

### Alpha Tab

The alpha keyboard is labeled using the language code. For English, the alpha keyboard is labeled **EN**.

### Additional Character Tab

The additional characters keyboard is labeled **#\*/**.

Touch 😊 to enter emoji icons in a text message.

Touch **ABC** to return to the Symbols keyboard.

### Scan Tab

The Scan tab provides an easy data capture feature for scanning barcodes.

## Language Usage

Use the **Language & input** settings to change the device's language, including words added to the dictionary.

### Changing the Language Setting

1. Go to **Settings**.
2. Touch **System > Languages & input**.
3. Touch **Languages**. A list of available languages displays.
4. If the desired language is not listed, touch **Add a language** and select a language from the list.
5. Touch and hold ≡ to the right of the desired language, then drag it to the top of the list.
6. The operating system text changes to the selected language.

### Adding Words to the Dictionary

1. Go to **Settings**.
2. Touch **System > Languages & input > Advanced > Personal dictionary**.
3. If prompted, select the language where this word or phrase is stored.
4. Touch **+** to add a new word or phrase to the dictionary.
5. Enter the word or phrase.
6. In the **Shortcut** text box, enter a shortcut for the word or phrase.
7. Touch the Home button.

## Notifications

### Setting App Notifications

To set notification settings for a specific app:

1. Go to **Settings**.
2. Touch **Apps & notifications > SEE ALL XX APPS**. The **App info** screen displays.
3. Select an app.
4. Touch **Notifications**.

Options vary depending on the app selected.

5. Select an available option:

**Show notifications** - Select to turn all notifications from this app on (default) or off.

Touch a notification category to display additional options.

- **Alerting** - Allow notifications from this app to make sound or vibrate the device.
  - **Pop on screen** - Allow notifications from this app to pop notifications on the screen.
- **Silent** - Do not allow notifications from this app to make sound or vibrate.
  - **Minimize** - In the Notification panel, collapse notifications to one line.
- **Advanced** - Touch for additional options.
  - **Sound** - Select a sound to play for notifications from this app.
  - **Vibrate** - Allow notifications from this app to vibrate the device.
  - **Blink light** - Allow notifications from this app the light the Notification LED blue.
  - **Show notification dot** - Allow notifications from this app to add a notification dot to the app icon.
  - **Override Do Not Disturb** - Allow these notifications to interrupt when Do Not Disturb is enabled.

#### Advanced

- **Allow notification dot** - Do not allow this app to add a notification dot to the app icon.
- **Additional settings in the app** - Open the app settings.

### Viewing Notification Settings for All Apps

To view the notification settings for all apps:

1. Go to **Settings**.
2. Touch **Apps & Notifications**.
3. Scroll down to **Notifications** to view how many apps have notifications turned off.
4. To set or view notifications settings for a specific app, see [Setting App Notifications on page 45](#).

### Controlling Lock Screen Notifications

To control whether notifications can be seen when the device is locked:

1. Go to **Settings**.
2. Touch **Apps & notifications > Notifications**.

3. Touch **Notifications on lockscreen** and select one of the following:
  - **Show alerting and silent notifications** (default)
  - **Show alerting notifications only**
  - **Don't show notifications.**

### **Blink Light**

The Notification LED lights blue when an app, such as email and VoIP, generates a programmable notification or to indicate when the device is connected to a Bluetooth device. By default, LED notifications are enabled.

To change the notification setting:









1. Go to **Settings**.
2. Touch **Apps & notifications > Notifications > Advanced**.
3. Touch **Blink light** to toggle the notification on or off.

# Applications

The **APPS** screen displays icons for all installed apps. See [Application Deployment](#) for information on installing and uninstalling apps. For information on standard Android apps, go to the Google Play [Apps store](#).













The following table describes the apps installed on the device.

**Table 1** Apps

Icon	Description
	<b>Battery Manager</b> - Displays battery information, including charge level, status, health and wear level.
	<b>Bluetooth Pairing Utility</b> – Use to pair a Zebra Bluetooth scanner with the device by scanning a barcode.
	<b>Calculator</b> - Provides the basic and scientific arithmetic functions.
	<b>Calendar</b> - Use to manage events and appointments. GMS/GMS-Restricted only.
	<b>Calendar</b> - Use to manage events and appointments. AOSP only.
	<b>Camera</b> - Take photos or record videos. For more information, see <a href="#">Camera on page 7</a> .
	<b>Chrome</b> - Use to access the Internet or intranet. GMS/GMS-Restricted only.
	<b>Chromium</b> - Use to access the Internet or intranet. AOSP only.
	<b>Clock</b> - Use to schedule alarms for appointments or as a wake-up.















## Applications

**Table 1** Apps (Continued)





Icon	Description
	<b>Contacts</b> - Use to manage contact information.
	<b>DataWedge</b> - Enables data capture using the imager. For more information, see <a href="#">DataWedge Demonstration on page 12</a> .
	<b>DisplayLink Presenter</b> - Use to present the device screen onto a connected monitor.
	<b>Drive</b> - Upload photos, videos, documents, and other files to personal storage site. GMS/GMS-Restricted only.
	<b>Duo</b> - A one-to-one video calling app. GMS/GMS-Restricted only.
	<b>DWDemo</b> - Provides a way to demonstrate the data capture features using the imager. For more information, see <a href="#">DataWedge Demonstration on page 12</a> .
	<b>Email</b> - Use to send and receive email. AOSP only.
	<b>Files</b> - Organize and manage files on the device.
	<b>Gallery</b> - Use to view photos stored on the microSD card. AOSP only.
	<b>Gmail</b> - Use to send and receive email using a Google email account. GMS/GMS-Restricted only.
	<b>Google</b> - Launches Google™ search app. GMS/GMS-Restricted only.
	<b>Keep Notes</b> - Use to create, edit, and share notes. GMS/GMS-Restricted only.
	<b>License Manager</b> - Use to manage software licenses on the device.
	<b>Maps</b> - Use to see your location on a map (with public transit, traffic, or satellite overlays). Search for any business or place of interest. Provides turn-by-turn navigation with voice guidance, traffic-avoidance, and alternate routes, for drivers, cyclists, walkers, and users of public transportation. GMS/GMS-Restricted only.



**Table 1** Apps (Continued)

Icon	Description
	<b>MSRN</b> - Use to verify authenticity of the paired Snap-on MSR and to provision the Snap-on MSR.
	<b>Music</b> - Play music stored on the microSD card or internal storage. AOSP only.
	<b>Phone</b> - Use to dial a phone number when used with some Voice over IP (VoIP) clients (VoIP telephony ready only).
	<b>Photos</b> - Use to sync photos with Google account. GMS/GMS-Restricted only.
	<b>Play Movies &amp; TV</b> - View movies and video on your device. GMS/GMS-Restricted only.
	<b>Play Store</b> - Download music, movies, books, and Android apps and games from the Google Play Store. GMS/GMS-Restricted only.
	<b>PTT Express</b> - Use to launch PTT Express client for VoIP communication.
	<b>RxLogger</b> - Use to diagnose device and app issues. For more information, see <a href="#">RxLogger on page 14</a> .
	<b>Search</b> - Use to search the Web. Requires an Internet connection. AOSP only.
	<b>Settings</b> - Use to configure the device.
	<b>Sound Recorder</b> - Use to record audio. For more information, see <a href="#">Sound Recorder on page 15</a> .
	<b>StageNow</b> - Allows the device to stage a device for initial use by initiating the deployment of settings, firmware, and software.
	<b>VC Settings</b> - Use to control settings for the device. See <a href="#">VC Settings on page 17</a> .
	<b>Videos</b> - Use to view videos on the device. AOSP only.

**Table 1** Apps (Continued)

Icon	Description
	<b>Worry Free Wifi Analyzer</b> - A diagnostic intelligent app. Use to diagnose surrounding area and display network stats, such as coverage hole detection, or AP in vicinity. Refer to the Worry Free Wi-Fi Analyzer Administrator Guide for Android.
	<b>YouTube</b> - Use to view videos on the YouTube™ web site. GMS/GMS-Restricted only.
	<b>YT Music</b> - Use to listen to music. GMS/GMS-Restricted only.
	<b>Zebra Bluetooth Settings</b> - Use to configure Bluetooth logging.
	<b>Zebra Data Services</b> - Use to enable or disable Zebra Data Services. Some options are set by the system administrator.

## Accessing Apps

All apps installed on the device are accessed using the **APPS** window.

1. On the Home screen, swipe up from the bottom of the screen.
2. Slide the **APPS** window up or down to view more app icons.
3. Touch an icon to open the app.

## Switching Between Recent Apps

Use the Recent button to switch between recently used apps.

1. Touch Recent button.  
A window appears on the screen with icons of recently used apps.
2. Slide the apps displayed up and down to view all recently used apps.
3. Swipe left or right to remove app from the list and force close the app.
4. Touch an icon to open an app or touch Back button to return to the current screen.

## Battery Manager

The **Battery Manager** provides detailed information about the battery and battery swap procedures on supported devices.



### Opening Battery Manager

To open the Battery Manager app, swipe up from the bottom of the Home screen, and then touch .

## Battery Manager Information Tab

The Battery Manager displays detailed information about battery charging, health, and status.

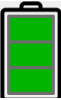
**Table 2** Battery Icon Description

Battery Icon	Description
	Battery charge level is between 85% and 100%.
	Battery charge level is between 19% and 84%.
	Battery charge level is between 0% and 18%.

- **Level** - The current battery charge level as a percentage. Displays -% when level is unknown.
- **Wear** - The health of the battery in graphical form. When the wear level exceeds 80%, the bar color changes to red.
- **Health** - The health of the battery. If a critical error occurs,  appears. Touch to view the error description.
  - **Decommission** - The battery is past its useful life and should be replaced. See system administrator.
  - **Good** - The battery is good.
  - **Charge error** - An error occurred while charging. See system administrator.
  - **Over Current** - An over-current condition occurred. See system administrator.
  - **Dead** - The battery has no charge. Replace the battery.
  - **Over Voltage** - An over-voltage condition occurred. See system administrator.
  - **Below Temperature** - The battery temperature is below the operating temperature. See system administrator.
  - **Failure Detected** - A failure has been detected in the battery. See system administrator.
  - **Unknown** - See system administrator.
- **Charge Status**
  - **Not charging** - The device is not connected to AC power.
  - **Charging-AC** - The device is connected to AC power and charging.
  - **Charging-USB** - The device is connected to a host computer with a USB cable and charging.
  - **Discharging** - The battery is discharging.
  - **Full** - That the battery is fully charged.
  - **Unknown** - The battery status is unknown.
- **Time until Full** - The amount of time until the battery is fully charged.
- **Time since charging** - The amount of time since the device began charging.

- **Time until empty** - The amount of time until the battery is empty.
- **Advanced info** - Touch to view additional battery information.
  - **Battery present status - Indicates that the battery is present.**
  - **Battery level** - The battery charge level as a percentage of scale.
  - **Battery scale** - The battery scale level used to determine battery level (100).
  - **Battery voltage** - The current battery voltage in millivolts.
  - **Battery temperature** - The current battery temperature in degrees Centigrade.
  - **Battery technology** - The type of battery.
  - **Battery current** - The average current into or out of the battery over the last second in mAh.
  - **Battery manufacture date** - The date of manufacture.
  - **Battery serial number** - The battery serial number. The number matches the serial number printed on the battery label.
  - **Battery part number** - The battery part number.
  - **Battery decommission status** - Indicates if the battery is past its life span.
    - **Battery Good** - The battery is in good health.
    - **Decommissioned Battery** - The battery is past its useful life and should be replaced.
  - **Base cumulative charge** - Cumulative charge using Zebra charging equipment only.
  - **Battery present capacity** - Maximum amount of charge that could be pulled from the battery under the present discharge conditions if the battery were fully charged.
  - **Battery health percentage** - With a range from **0** to **100**, this is the ratio of “present\_capacity” to “design\_capacity” at a discharge rate of “design\_capacity”.
  - **% decommission threshold** - The default % decommission threshold for a gifted battery as 80%.
  - **Battery present charge** - Amount of usable charge remaining in the battery at present under the current discharge conditions.
  - **Battery total cumulative charge** - The total accumulated charge in all chargers.
  - **Battery time since first use** - The time passed since the battery was placed in a Zebra terminal for the first time.
  - **Battery error status** - The error status of the battery.
  - **App version** - The application version number.

## Camera



**NOTE:** The device saves photos and videos on the microSD card, if installed and the storage path is changed manually. By default, or if a microSD card is not installed, the device saves photos and videos on the internal storage.

This section provides information for taking photos and recording videos using the integrated digital cameras.



## Taking Photos

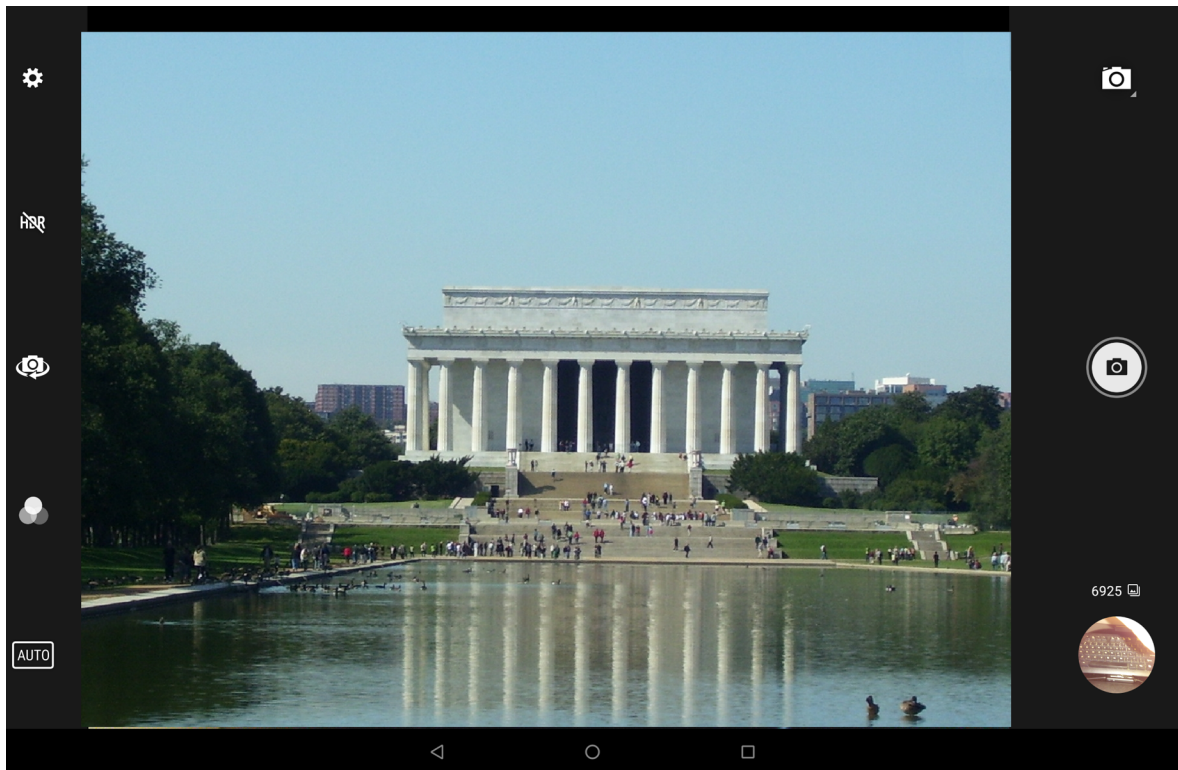

**NOTE:** See [Camera Settings on page 10](#) for camera setting descriptions.

1. Swipe up from the bottom of the Home screen and touch **Camera**.







2. If necessary, touch the Camera Mode icon and touch .
  3. Frame the subject on the screen.
  4. To zoom in or out, press two fingers on the display and pinch or expand fingers. The zoom controls appear on the screen.
  5. Touch an area on the screen to focus. The focus circle appears. The two bars turn green when in focus.
  6. Touch .
- The camera takes a photo and a shutter sound plays.
- The photo momentarily displays as a thumbnail in the lower left corner.

## Taking a Panoramic Photo

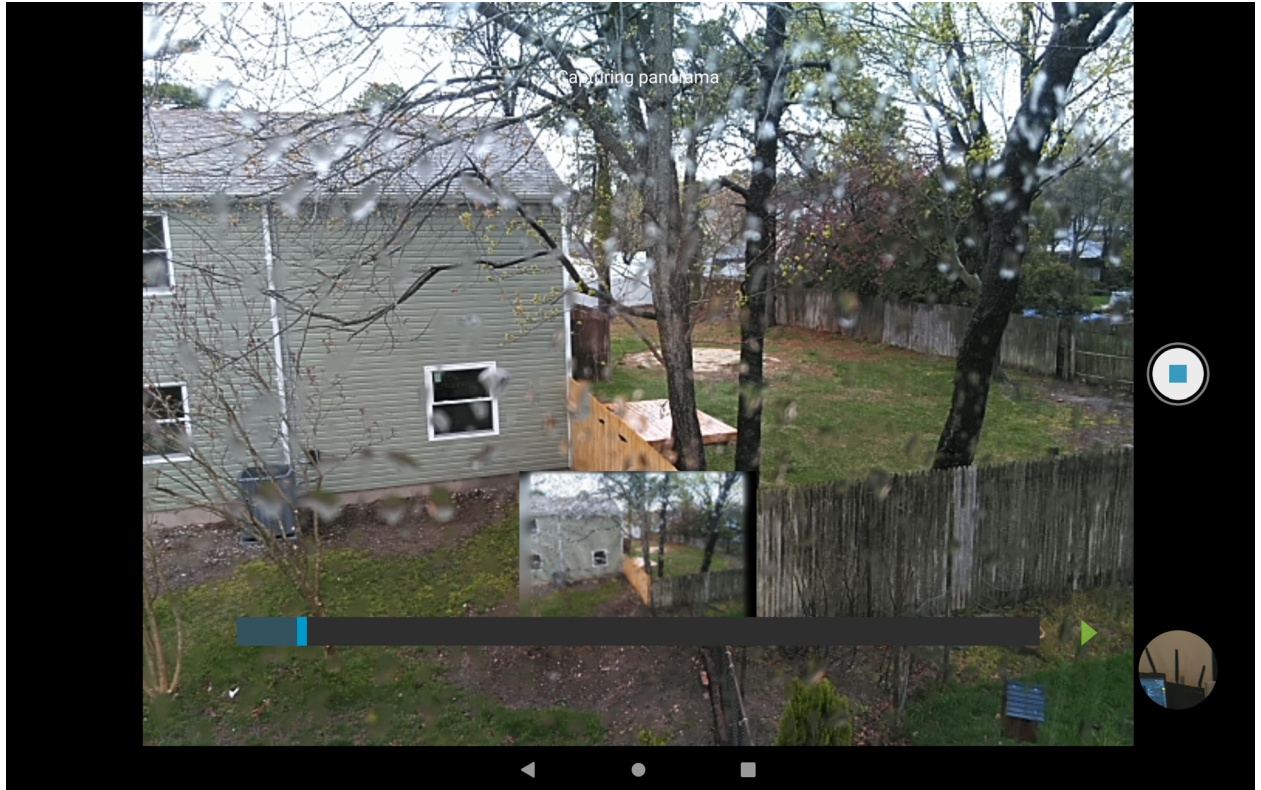
Panorama mode creates a single wide image by panning slowly across a scene.

1. Swipe up from the bottom of the Home screen and touch **Camera**.





2. Touch the Camera Mode icon and touch .
3. Frame one side of the scene to capture.
4. Touch  and slowly pan across the area to capture. A small white square appears inside the button indicating the capture is in progress.  
If you are panning too quickly, the message **Too fast** appears.
5. Touch  to end the shot. The panorama appears immediately and a progress indicator displays while it saves the image.

## Recording Videos

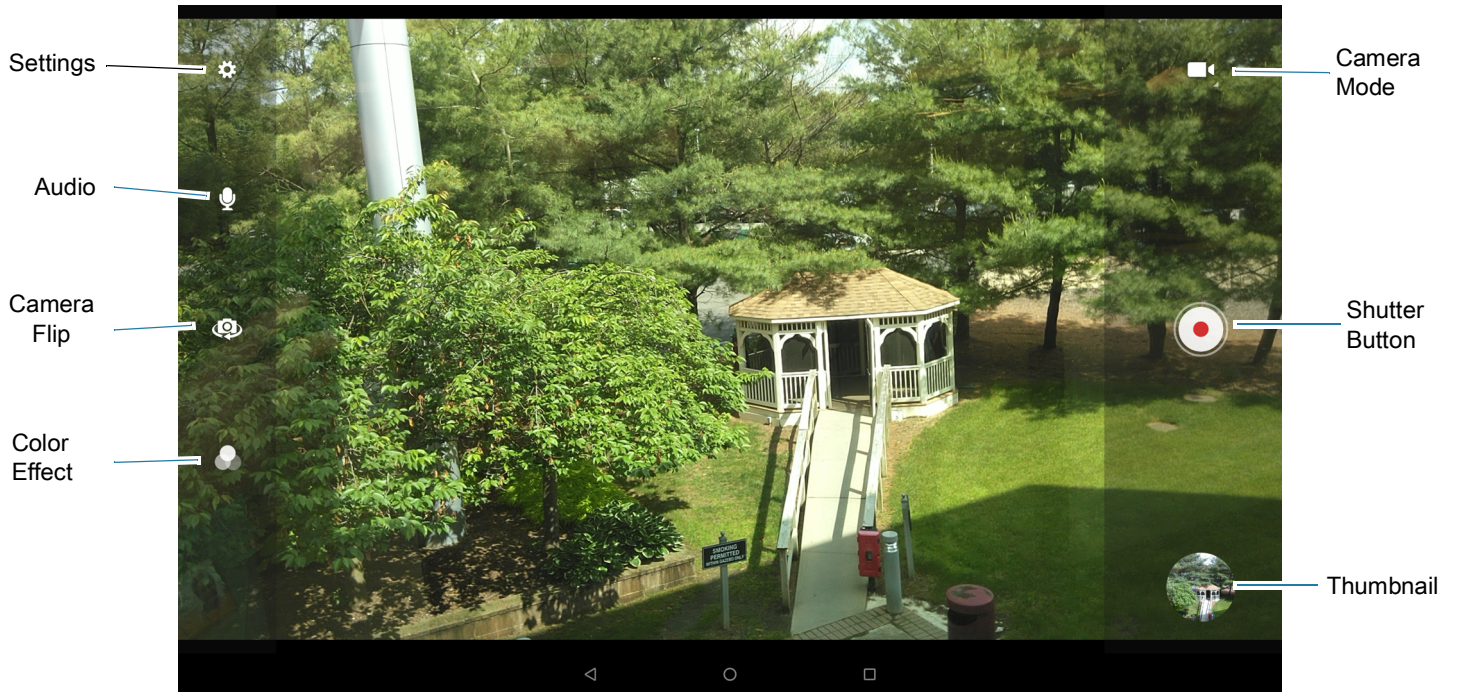
1. Swipe up from the bottom of the Home screen and touch **Camera**.
2. Touch the camera mode menu and touch .











3. Point the camera and frame the scene.
4. To zoom in or out, press two fingers on the display and pinch or expand fingers. The zoom controls appear on the screen.
5. Touch  to start recording.  
The video time remaining appears in the top left of the screen.
6. Touch  to end the recording.  
The video momentarily displays as a thumbnail in the lower left corner.

## Photo Settings

In Photo mode, photo settings appear on screen. Touch  to display the photo settings options.

### Rear Camera Photo Settings





- **Flash** - Select whether the camera relies on its light meter to decide whether a flash is necessary, or to turn it on or off for all shots.
  -  **Off** - Disable flash.
  -  **Auto** - Adjust flash automatically depending upon light meter (default).
  -  **On** - Enable flash upon taking a photo.
- **GPS location** - Add GPS location information to the photo meta-data. Turn **On** or **Off** (default). (ET56 only).
- **Picture size** - The size (in pixels) of the photo to: **13M pixels** (default), **8M pixels**, **5M pixels**, **3M pixels**, **HD 1080**, **2M pixels**, **HD720**, **1M pixels**, **WVGA**, **VGA**, or **QVGA**.
- **Picture quality** - Set the picture quality setting to: **Low**, **Standard** or **High** (default).
- **Countdown timer** - Select **Off** (default), **2 seconds**, **5 seconds** or **10 seconds**.

- **Storage** – Set the location to store the photo to: **Phone** or **SD Card**.
- **Continuous Shot** - Select to take a series of photos quickly while holding the capture button. **Off** (default) or **On**.
- **Face Detection** - Set the camera to automatically adjust the focus for faces.
- **ISO** - Set camera sensitivity to light to: **Auto** (default), **ISO Auto (HJR)**, **ISO100**, **ISO200**, **ISO400**, **ISO800** or **ISO1600**.
- **Exposure** - Set the exposure settings to: **+2**, **+1**, **0**(default), **-1** or **-2**.
- **White balance** - Select how the camera adjusts colors in different kinds of light, to achieve the most natural-looking colors:
  -  **Incandescent** - Adjust the white balance for incandescent lighting.
  -  **Fluorescent** - Adjust the white balance for florescent lighting.
  -  **Auto** - Adjust the white balance automatically (default).
  -  **Daylight** - Adjust the white balance for daylight.
  -  **Cloudy** - Adjust the white balance for a cloudy environment.
- **Redeye reduction** - Helps eliminate redeye effect. Options: **Disabled** (default), or **Enable**.
- **ZSL** - Set the camera to immediately take a picture when the button is pressed (default – enabled).
- **Shutter Sound** - Select to play a shutter sound when taking a photo. Options: **Disable** (default) or **Enable**.
- **Anti Banding** - Allows the camera to avoid problems caused by artificial light sources that are not constant. These sources cycle (flicker) fast enough to go unnoticed to the human eye, appearing continuous. The camera's eye (its sensor) can still see this flicker. Options: **Auto** (default), **60 Hz**, **50 Hz**, or **Off**.

### Front Camera Photo Settings

- **Selfie Flash** - Turns screen white to help produce a little extra light in dimmer settings. Options: **Off** (default), or **On**.
- **GPS location** - **Add GPS location information to the photo meta-data. Options: On or Off (default). (ET56 only).**
- **Picture size** - Set the size (in pixels) of the photo to: **5M pixels** (default), **3M pixels**, **HD1080**, **2M pixels**, **HD720**, **1M pixels**, **WVGA**, **VGA**, or **QVGA**.
- **Picture quality** - Set the picture quality setting to: **Low**, **Standard** or **High** (default).
- **Countdown timer** - Set to: **Off** (default), **2 seconds**, **5 seconds** or **10 seconds**.
- **Storage** – Set location to store the photo to: **Phone** or **SD Card**.
- **Continuous Shot** - Select to take a series of photos quickly while holding the capture button. **Off** (default) or **On**.
- **Face Detection** - Select to turn face detection **Off** (default) or **On**.
- **ISO** - Set how sensitive the camera is to light. Options: **Auto** (default), **ISO Auto (HJR)**, **ISO100**, **ISO200**, **ISO400**, **ISO800** or **ISO1600**.
- **Exposure** - Touch to adjust the exposure settings. Options: **+2**, **+1**, **0** (default), **-1** or **-2**.









- **White balance** - Select how the camera adjusts colors in different kinds of light, to achieve the most natural-looking colors:
  -  **Incandescent** - Adjust the white balance for incandescent lighting.
  -  **Fluorescent** - Adjust the white balance for florescent lighting.
  -  **Auto** - Adjust the white balance automatically (default).
  -  **Daylight** - Adjust the white balance for daylight.
  -  **Cloudy** - Adjust the white balance for a cloudy environment.
- **Redeye reduction** - Helps eliminate redeye effect. Options: **Disabled** (default), or **Enable**.
- **ZSL** - Set the camera to immediately take a picture when the button is pressed (default – enabled)
- **Selfie Mirror** - Select to save a mirror image of the photo. Options: **Disable** (default), or **Enable**.
- **Shutter Sound** - Select to play a shutter sound when taking a photo. Options: **Disable** (default) or **Enable**.
- **Anti Banding** - Allows the camera to avoid problems caused by artificial light sources that are not constant. These sources cycle (flicker) fast enough to go unnoticed to the human eye, appearing continuous. The camera's eye (its sensor) can still see this flicker. Options: **Auto** (default), **60 Hz**, **50 Hz**, or **Off**.

## Video Settings





In Video mode, video settings appear on screen. Touch  to display the video settings options.

### Rear Camera Video Settings

- **Flash** - Select whether Rear-facing Camera relies on its light meter to decide whether a flash is necessary, or to turn it on or off for all shots.
  -  **Off** - Disable flash (default).
  -  **On** - Enable flash.
- **Video quality** - Set video quality to: **4k DCI**, **4k UHD**, **HD 1080p** (default), **HD 720p**, **SD 480p**, **VGA**, **CIF**, or **QVGA**.
- **Video duration** - Set to: **30 seconds (MMS)**, **10 minutes**, **30 minutes (default)**, or **no limit**.
- **GPS location** - Add GPS location information to the photo meta-data. **Turn On** or **Off (default)**. **(ET56 only)**.
- **Storage** – Set the location to store the photo to: **Phone** (default) or **SD Card**.
- **White balance** - Select how the camera adjusts colors in different kinds of light, to achieve the most natural-looking colors.
  -  **Incandescent** - Adjust the white balance for incandescent lighting.
  -  **Fluorescent** - Adjust the white balance for florescent lighting.
  -  **Auto** - Adjust the white balance automatically (default).
  -  **Daylight** - Adjust the white balance for daylight.

-  **Cloudy** - Adjust the white balance for a cloudy environment.
- **Image Stabilization** - Set to reduce blurry videos due to device movement. Options: **On** or **Off** (default).

## Front Camera Video Settings

- **Video quality** - Set video quality to: **HD1080p** (default), **HD 720p**, **SD 480p**, **VGA**, **CIF**, or **QVGA**.
- **Video duration** - Set to: **30 seconds (MMS)**, **10 minutes**, **30 minutes** (default), or **no limit**.
- **GPS location** - **Add GPS location information to the photo meta-data**. Turn **On** or **Off** (default). (ET56 only).
- **Storage** – Set the location to store the photo to: **Phone** (default) or **SD Card**.
- **White balance** - Select how the camera adjusts colors in different kinds of light, to achieve the most natural-looking colors.
  -  **Incandescent** - Adjust the white balance for incandescent lighting.
  -  **Fluorescent** - Adjust the white balance for florescent lighting.
  -  **Auto** - Adjust the white balance automatically (default).
  -  **Daylight** - Adjust the white balance for daylight.
  -  **Cloudy** - Adjust the white balance for a cloudy environment.
- **Image Stabilization** - Set to reduce blurry videos due to device movement. Options: **On** or **Off** (default).





## DataWedge Demonstration

Use **DataWedge Demonstration** to demonstrate data capture functionality. To configure DataWedge, refer to [techdocs.zebra.com/datawedge/](http://techdocs.zebra.com/datawedge/).









**NOTE:** DataWedge is enabled on the Home screen. To disable this feature, go to the DataWedge settings and disable the **Launcher** profile.

**Table 3** DataWedge Demonstration Icons

	Icon	Description
Illumination		Imager illumination is on. Touch to turn illumination off.
		Imager illumination is off. Touch to turn illumination on.
Data Capture		Indicates a USB scanner is connected to the device.
		Indicates a USB scanner is not connected to the device.

**Table 3** DataWedge Demonstration Icons (Continued)

	Icon	Description
		A Bluetooth scanner is connected.
		A Bluetooth scanner is not connected.
		The data capture function is through the rear camera.
Scan Mode		Imager is in picklist mode. Touch to change to normal scan mode.
		Imager is in normal scan mode. Touch to change to picklist mode.
Menu		Opens a menu to view the application information or to set the application DataWedge profile.

## Scanner Selection

To select a scanner, touch  > **Settings** > **Scanner selection**.

See the Data Capture section for more information.

Press the scanner trigger button or touch the on-screen yellow scan button to capture data. The data appears in the text field below the yellow button.

## RxLogger

RxLogger is a comprehensive diagnostic tool that provides application and system metrics, and diagnoses device and application issues. RxLogger logs the following information: CPU load, memory load, memory snapshots, battery consumption, power states, wireless logging, cellular logging, TCP dumps, Bluetooth logging, GPS logging, logcat, FTP push/pull, ANR dumps, etc. All generated logs and files are saved onto flash storage on the device (internal or external).

### RxLogger Configuration

RxLogger is built with an extensible plug-in architecture and comes packaged with a number of plug-ins already built-in. For information on configuring RxLogger, refer to [techdocs.zebra.com/rxlogger/](http://techdocs.zebra.com/rxlogger/).

To open the configuration screen, from the RxLogger home screen touch **Settings**.

### Configuration File

RxLogger configuration can be set using an XML file. The `config.xml` configuration file is located in the `RxLogger\config` folder. Copy the file from the device to a host computer using a USB connection. Edit the configuration file and then replace the XML file on the device. There is no need to stop and restart the RxLogger service since the file change is automatically detected.

### Enabling Logging

To enable logging:

1. Swipe the screen up and select .
2. Touch **Start**.
3. Touch the Home button.

### Disabling Logging

To disable logging:

1. Swipe the screen up and select .
2. Touch **Stop**.
3. Touch the Home button.

### Extracting Log Files

1. Connect the device to a host computer using an USB connection.
2. Using a file explorer, navigate to the `RxLogger` folder.
3. Copy the file from the device to the host computer.
4. Disconnect the device from the host computer.

### Backing Up

RxLogger Utility allows the user to make a zip file of the `RxLogger` folder in the device, which by default contains all the RxLogger logs stored in the device.

To save the backup data, touch  > **BackupNow**.

### RxLogger Utility

RxLogger Utility is a data monitoring application for viewing logs in the device while RxLogger is running. Logs and RxLogger Utility features are accessed using Main Chat Head.

#### Initiating the Main Chat Head

To initiate the Main Chat Head:

1. Open **RxLogger**.
2. Touch  > **Toggle Chat Head**. The Main Chat Head icon appears on the screen.
3. Touch and drag the Main Chat head icon to move it around the screen.

#### Removing the Main Chat Head

To remove the Main Chat Head icon:

1. Touch and drag the icon. A circle with an X appears.
2. Move the icon over the circle and then release.

#### Viewing Logs

To view logs:

1. Touch the Main Chat Head icon. The RxLogger Utility screen appears.
2. Touch a log to open it. The user can open many logs with each displaying a new sub Chat Head.
3. If necessary, scroll left or right to view additional Sub Chat Head icons.
4. Touch a Sub Chat Head to display the log contents.

#### Removing a Sub Chat Head Icon

To remove a sub chat Head icon, press and hold the icon until it disappears.

#### Backing Up In Overlay View

RxLogger Utility allows the user to make a zip file of the **RxLogger** folder in the device, which by default contains all the RxLogger logs stored in the device.

The Backup icon is always available in Overlay View.

1. Touch . The Backup dialog box appears.
2. Touch **Yes** to create the back up.

### Sound Recorder

Use **Sound Recorder** to record audio messages.

Recordings are saved on the microSD card (if installed) or the internal storage, and are available in the Music application (AOSP devices) or the Play Music application (GMS devices).

Touch  to open options menu.

- **File type** - Select the file type for the recording file.
  - **AMR**
  - **3GPP**
  - **AAC**
  - **WAV**
  - **AMR-WB**
  - **AMR-WB-3GPP.**
- **Storage location** - Select the location for the recording file.
  - **Phone storage**
  - **SD card**

## VC Settings

Use the **VC Settings** app with a third-party vehicle cradle.

### Display

Enable/disable **Stay awake** to keep the device awake when the external power source is connected.

### Screen Blanking

The optional Screen Blanking setting turns the screen off when the vehicle is moving and back on when the vehicle stops.



To use Screen Blanking, first connect a serial ports on the vehicle cradle to a user-supplied switch or relay.

- **Screen Blanking** - Enable/disable screen blanking feature.
- **Input signal** - Select the port that the screen blank cable is connected to. Options: **Input 1** or **Input 2**.
- **Source polarity** - Select blank screen option. De-select to disconnect the blank screen option.
- **Blank screen delay** - Set the amount of time after the device receives the signal to blank the screen. Options 1 to 30 seconds (default - 1).

# Data Capture

The device supports data capture using:

- integrated camera
- integrated scanner (ET51 with Integrated Scanner only)
- SE4750 Expansion Back
- Ring scanners:
  - RS507 and RS507X Hands-free Imager
  - RS5100 Ring Scanner
  - RS6000 Ring Scanner
- Bluetooth scanners:
  - DS2278, and DS3678 scanners
- USB scanners:
  - LI3608, and DS3608.

## Imaging

The imager uses imaging technology to take a picture of a bar code, stores the resulting image in its memory, and executes state-of-the-art software decoding algorithms to extract the bar code data from the image.

The device with a 2D imager has the following features:

- Omnidirectional reading of a variety of bar code symbologies, including the most popular linear, postal, PDF417, and 2D matrix code types.
- Advanced intuitive laser aiming cross-hair and dot aiming for easy point-and-shoot operation.

## Scanning Considerations

Typically, scanning is a simple matter of aim, scan, and decode, with a few quick trial efforts to master it. However, consider the following to optimize scanning performance:

- **Range:** Scanners decode best over a particular working range — minimum and maximum distances from the barcode. This range varies according to barcode density and scanning device optics. Scan within range for quick and constant decodes; scanning too close or too far away prevents decodes. Move the scanner closer and further away to find the right working range for the barcodes being scanned.



- **Angle:** Scanning angle is important for quick decodes. When the illumination/flash reflects directly back into the imager, the specular reflection can blind/saturate the imager. To avoid this, scan the barcode so that the beam does not bounce directly back. Do not scan at too sharp an angle; the scanner needs to collect scattered reflections from the scan to make a successful decode. Practice quickly shows what tolerances to work within.
- Hold the device farther away for larger symbols.
- Move the device closer for symbols with bars that are close together.



**NOTE:** Scanning procedures depend on the app and device configuration. An app may use different scanning procedures from the one listed above.

## Expansion Back

The Expansion Back is a bar code scanning solutions for both 1D and 2D bar code symbologies that attach to the tablet. Expansion Back is available for the 8.4" and 10.1" tablet.

Install the Expansion Back prior to use. Refer to the ET51/56 Integration Guide for installation instructions.

## Integrated Scanner

The ET51 Enterprise Tablet with Integrated Scanner contains a built-in 2D scan engine for both 1D and 2D bar code symbologies.

## RS507/RS507X Hands-Free Imager

The RS507/RS507X Hands-free Imager is a wearable barcode scan solution for both 1D and 2D barcode symbologies.

**Figure 1** RS507/RS507X Hands-Free Imager

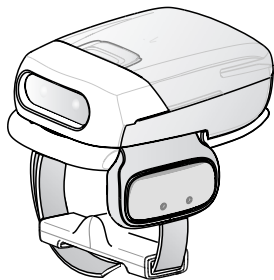

Refer to the RS507/RS507X Hands-free Imager Product Reference Guide for more information.

## RS5100 Ring Scanner

The RS5100 Ring Scanner is a wearable barcode scan solution for both 1D and 2D bar code symbologies.

**Figure 2** RS5100 Ring Scanner

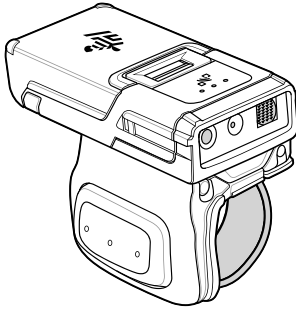

Refer to the RS5100 Ring Scanner Product Reference Guide for more information.

## **RS6000 Bluetooth Ring Scanner**

The RS6000 Bluetooth Ring Scanner is a wearable barcode scan solution for both 1D and 2D barcode symbologies.

**Figure 3** RS6000 Bluetooth Ring Scanner

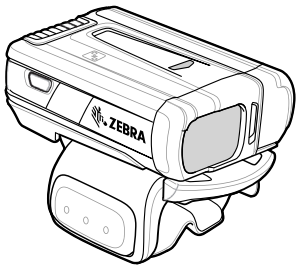

Refer to the RS6000 Bluetooth Ring Scanner Product Reference Guide for more information.

## **DS36X8 Digital Scanner**

The corded DS3608 and the cordless DS3678 combines superior 1D and 2D omnidirectional barcode scanning performance and advanced ergonomics in a lightweight design. See the DS36X8 Product Reference Guide for more information.

**Figure 4** DS36X8 Digital Scanner

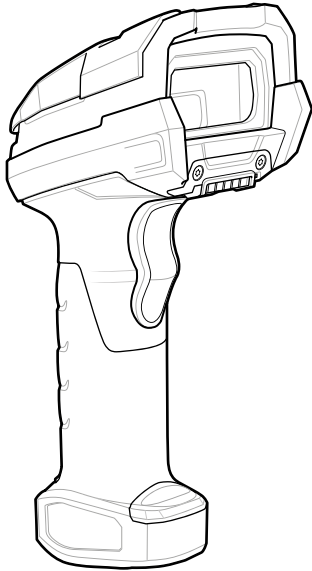

## **DS2278 Digital Scanner**

The DS2278 digital imager scanner scans both 1D and 2D bar codes and does not compromise performance or features.

**Figure 5** DS2278 Digital Scanner

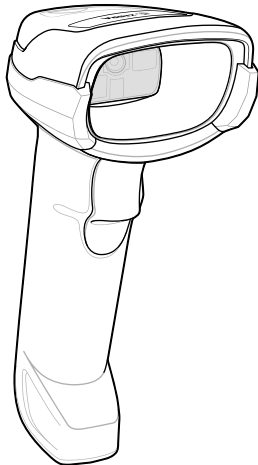

Refer to the DS22788 Digital Scanner Product Reference Guide for more information.

## **DS8178 Scanner**

The DS8178 digital imager scanner scans both 1D and 2D bar codes and does not compromise performance or features.

**Figure 6** DS8178 Digital Scanner

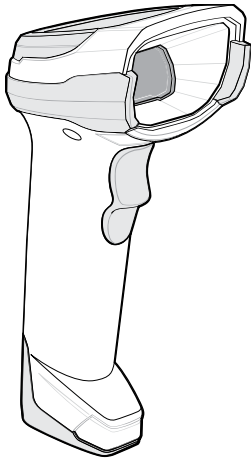

Refer to the DS8178 Digital Scanner Product Reference Guide for more information.

## Scanning with SE4750 Expansion Back

To read a barcode, a scan-enabled app is required. The device contains the DataWedge app that allows the user to enable the scanner to decode barcode data and display the barcode content.

To scan with the SE4750 Expansion Back:

1. Ensure that an app is open on the device and a text field is in focus (text cursor in text field).
2. Point the Expansion Back exit window at a bar code.

**Figure 7** Bar Code Scanning with Expansion Back with SE4750

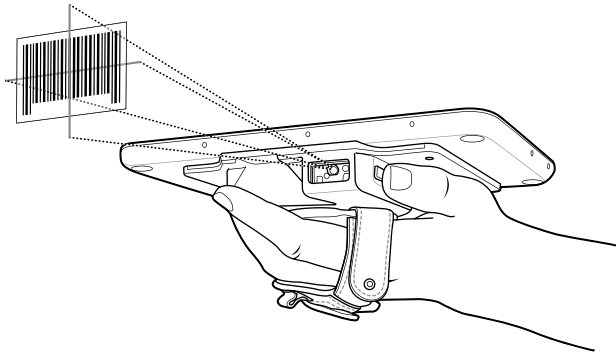

3. Press and hold the Scan button.

The red laser aiming pattern turns on to assist in aiming. Ensure the bar code is within the area formed by the cross-hairs in the aiming pattern. The aiming dot is used for increased visibility in bright lighting conditions.

The Expansion Back beeps to indicate the bar code was decoded successfully.

**Figure 8** SE4750 Expansion Back Aiming Pattern

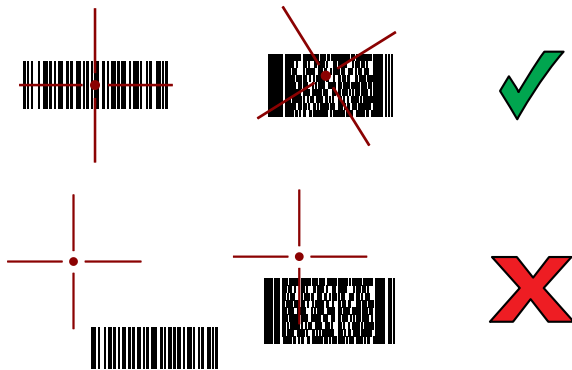

Release the Scan button. The bar code data displays on the screen.

## Scanning with the Integrated Scanner

To read a barcode, a scan-enabled app is required. Devices that contain the Zebra DataWedge app allows you to enable the scanner to decode barcode data and display the barcode content.

To scan with the integrated scanner:

1. Ensure that an app is open on the device and a text field is in focus (text cursor in text field).
2. Point the device at a barcode.

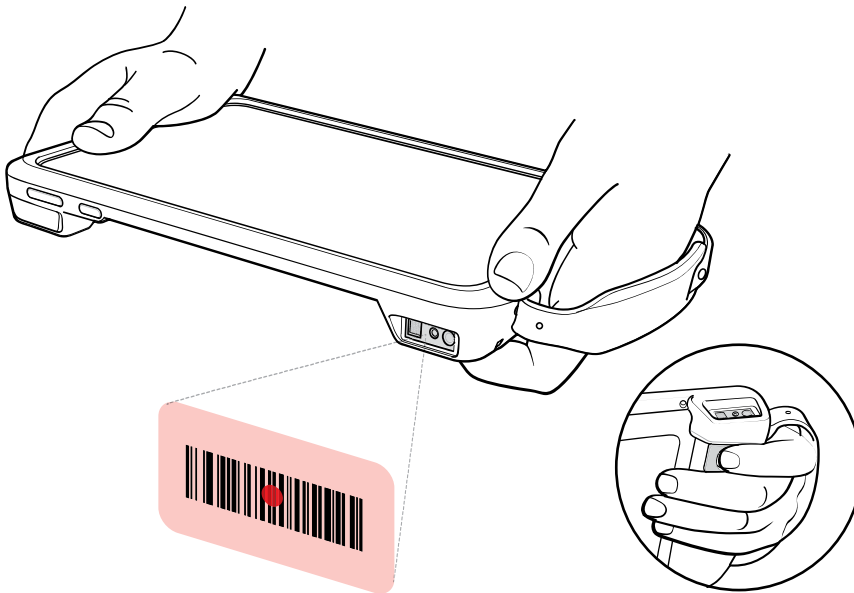

3. Press and hold one of the triggers.
4. Ensure the barcode is within the area formed by the aiming pattern. The aiming dot increases visibility in bright lighting conditions.

A beep sounds to indicate the barcode was decoded successfully. When the Integrated Scanner is in Pick List mode, the device does not decode the barcode until the aiming dot touches the barcode.

**Figure 9** Integrated Scanner Aiming Pattern

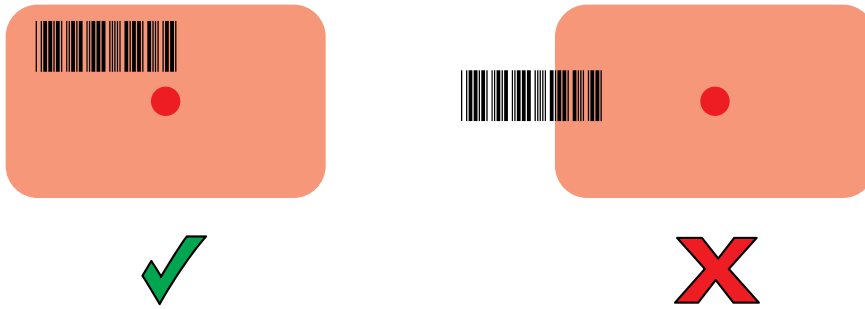

**Figure 10** Integrated Scanner Pick List Mode with Multiple Barcodes in Aiming Pattern

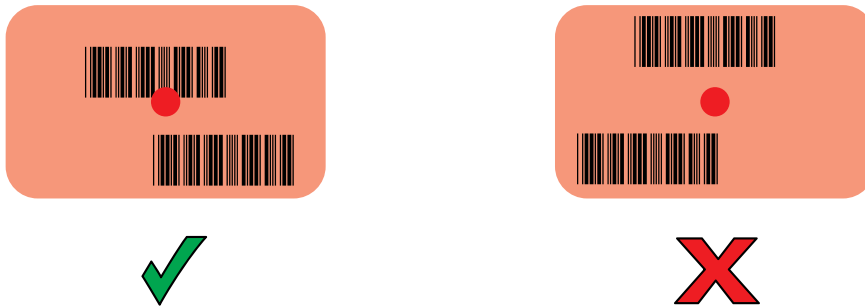

5. The captured data appears in the text field.

## Scanning with RS507/RS507X Hands-Free Imager

To read a barcode, a scan-enabled app is required. The device contains the DataWedge app that allows you to enable the scanner to decode barcode data and display the barcode content.

To scan with the RS507/RS507X:

1. Pair the RS507/RS507X with the device. [Pairing a Bluetooth Scanner on page 32](#) for more information.
2. Ensure that an app is open on the device and a text field is in focus (text cursor in text field).
3. Point the RS507/RS507X at a barcode.

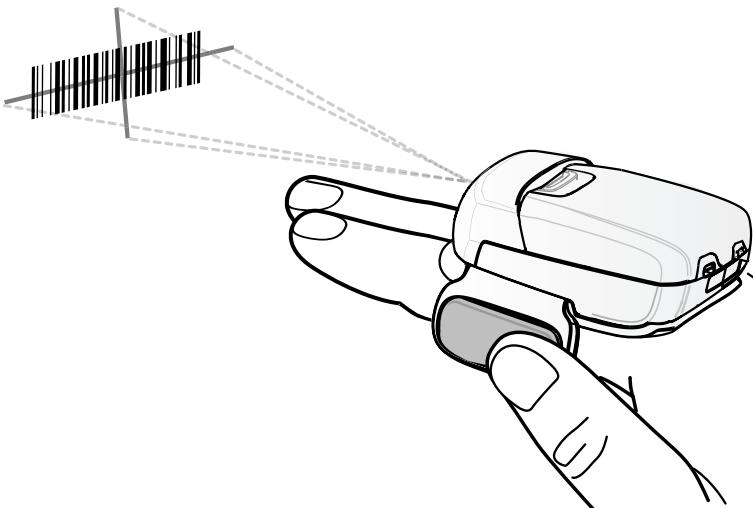

4. Press and hold the trigger.

The red laser aiming pattern turns on to assist in aiming. Ensure the barcode is within the area formed by the cross-hairs in the aiming pattern. The aiming dot increases visibility in bright lighting conditions.

The RS507/RS507X LEDs light green and a beep sounds to indicate the barcode was decoded successfully. When the RS507/RS507X is in Pick List mode, the RS507/RS507X does not decode the barcode until the center of the crosshair touches the barcode.

**Figure 11** RS507/RS507X Aiming Pattern

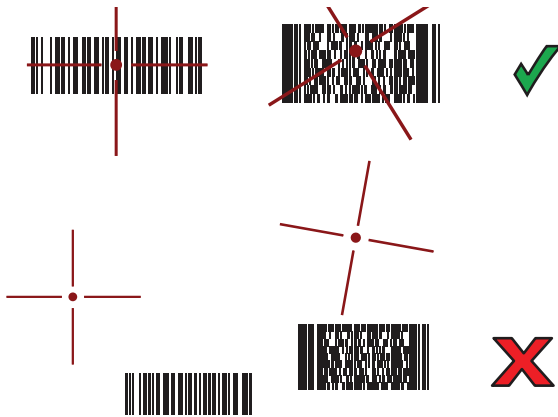

**Figure 12** RS507/RS507X Pick List Mode with Multiple Barcodes in Aiming Pattern



5. The captured data appears in the text field.

## Scanning with RS5100 Ring Scanner

To read a barcode, a scan-enabled app is required. The device contains the DataWedge app that allows you to enable the scanner to decode barcode data and display the barcode content.

To scan with the RS5100:

1. Pair the RS5100 with the device. See [Pairing a Bluetooth Scanner on page 32](#) for more information.
2. Ensure that an app is open on the device and a text field is in focus (text cursor in text field).

3. Point the RS5100 at a barcode.

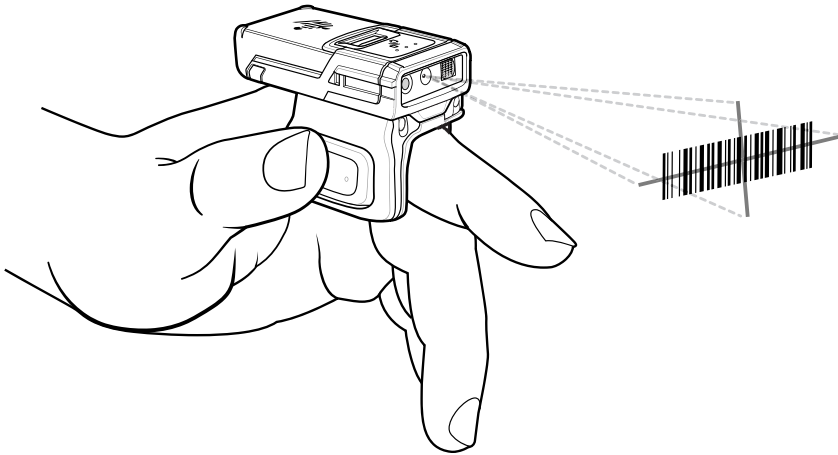

4. Press and hold the trigger.

The red laser aiming pattern turns on to assist in aiming. Ensure the barcode is within the area formed by the cross-hairs in the aiming pattern. The aiming dot increases visibility in bright lighting conditions.

The RS5100 LEDs light green and a beep sounds to indicate the barcode was decoded successfully. When the RS5100 is in Pick List mode, the RS5100 does not decode the barcode until the center of the crosshair touches the barcode.

**Figure 13** RS5100 Aiming Pattern

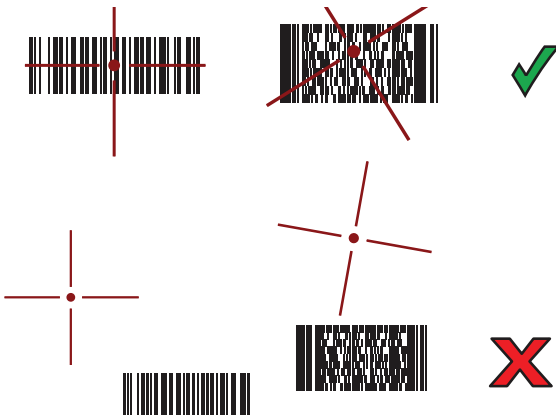

**Figure 14** RS5100 Pick List Mode with Multiple Barcodes in Aiming Pattern



5. The captured data appears in the text field.



## Scanning with RS6000 Bluetooth Ring Scanner

To read a barcode, a scan-enabled app is required. Devices that contain the Zebra DataWedge app allows you to enable the scanner to decode barcode data and display the barcode content.

To scan with the RS6000:

1. Pair the RS6000 with the device. See [Pairing a Bluetooth Scanner on page 32](#) for more information.
2. Ensure that an app is open on the device and a text field is in focus (text cursor in text field).
3. Point the RS6000 at a barcode.

**Figure 15** Barcode Scanning with RS6000

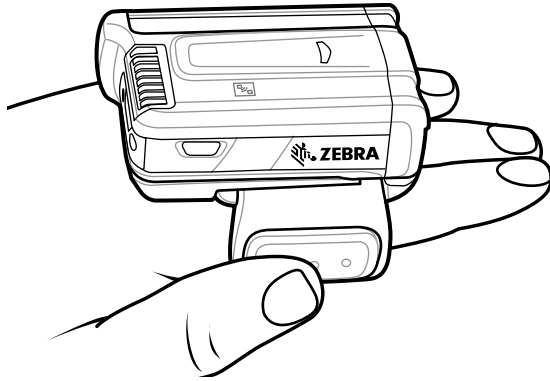

4. Press and hold the trigger.

The red laser aiming pattern turns on to assist in aiming. Ensure the barcode is within the area formed by the cross-hairs in the aiming pattern. The aiming dot increases visibility in bright lighting conditions.

The RS6000 LEDs light green and a beep sounds to indicate the barcode was decoded successfully. When the RS6000 is in Pick List mode, the RS6000 does not decode the barcode until the center of the crosshair touches the barcode.

**Figure 16** RS6000 Aiming Pattern

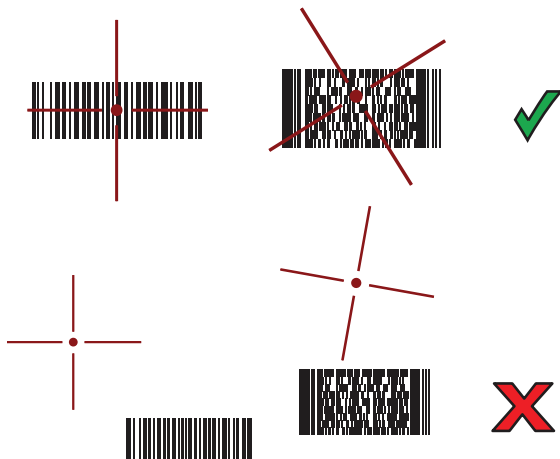

**Figure 17** RS6000 Pick List Mode with Multiple Barcodes in Aiming Pattern



5. The captured data appears in the text field.

## Scanning with the DS36X8 Scanner

To scan:

1. Connect the USB scanner to the device or pair the Bluetooth scanner with the device. For more information, see [Connecting a USB Scanner on page 33](#) for the USB scanners or [Pairing a Bluetooth Scanner on page 32](#) for Bluetooth scanners.
2. Ensure that an app is open on the device and a text field is in focus (text cursor in text field).
3. Point the scanner at a barcode.

**Figure 18** Barcode Scanning (DS3678 shown)

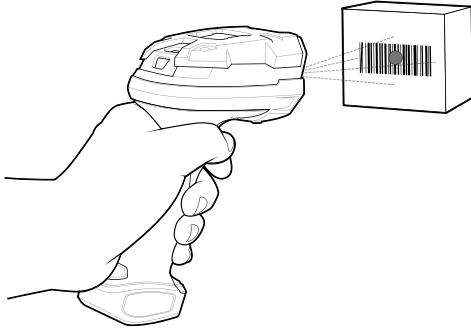

4. Press and hold the trigger.

Ensure the barcode is within the area formed by the aiming pattern. The aiming dot increases visibility in bright lighting conditions.

**Figure 19** DS36X8 Aiming Pattern

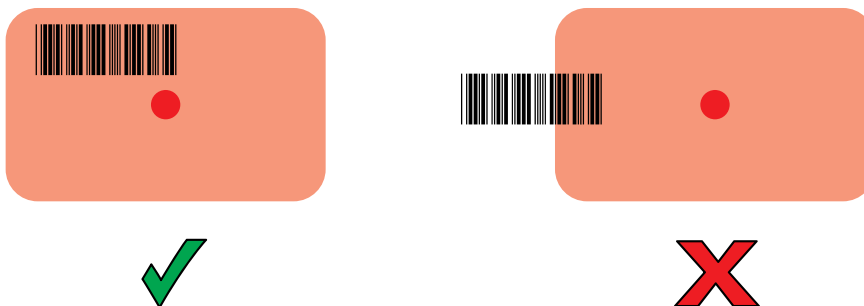

**Figure 20** DS36X8 Pick List Mode with Multiple Barcodes in Aiming Pattern

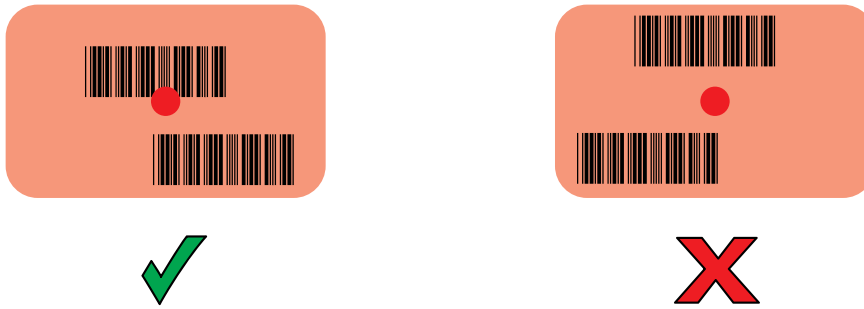

5. The captured data appears in the text field.

## Scanning with DS2278 Digital Scanner

To scan with the DS2278:

1. Pair the DS2278 with the device. See [Pairing a Bluetooth Scanner on page 32](#) for more information.
2. Ensure that an app is open on the device and a text field is in focus (text cursor in text field).
3. Point the scanner at a barcode.

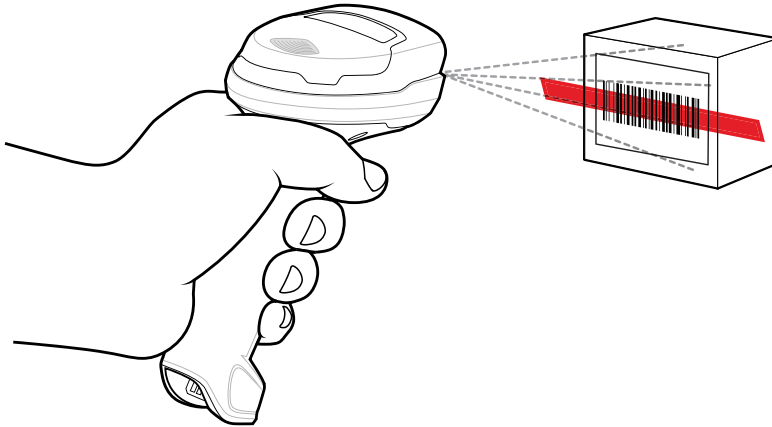

4. Press and hold the trigger.
5. Ensure the aiming pattern covers the barcode.

**Figure 21** DS2278 Aiming Pattern



6. Upon successful decode, the scanner beeps and the LED flashes, and the scan line turns off.
7. The captured data appears in the text field.

## Scanning with DS8178 Digital Scanner

To scan with the DS8178:

1. Pair the DS8178 with the device. See [Pairing a Bluetooth Scanner on page 32](#) for more information.
2. Ensure that an app is open on the device and a text field is in focus (text cursor in text field).
3. Point the scanner at a barcode.

**Figure 22** Barcode Scanning with DS8178

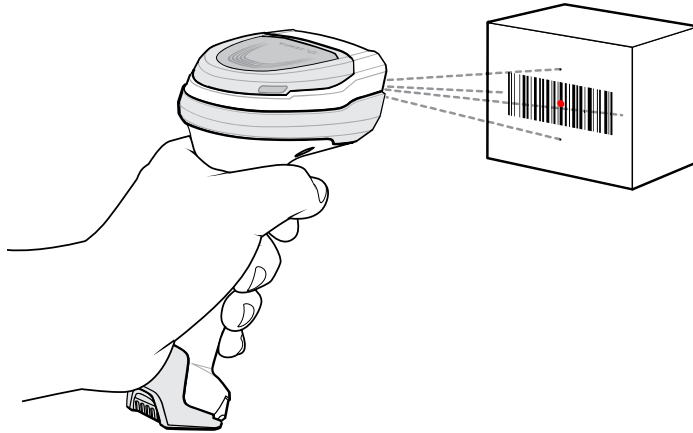

4. Press and hold the trigger.
5. Ensure the aiming pattern covers the barcode.

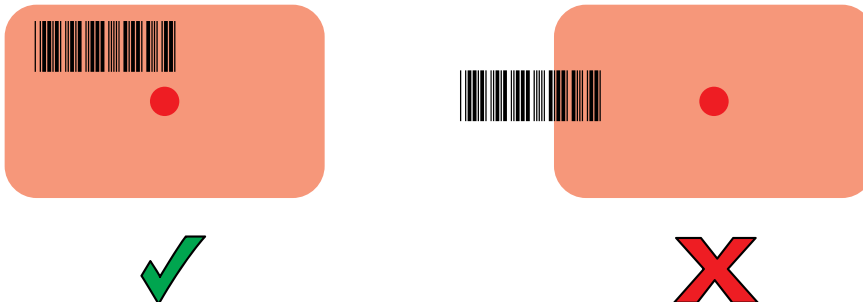

6. Upon successful decode, the scanner beeps and the LED flashes, and the scan line turns off.
7. The captured data appears in the text field.

## Pairing the RS507/RS5100/RS6000 Ring Scanner

To connect the ring scanner to the device, use one of the following methods:

- Simple Serial Interface (SSI)
- Bluetooth Human Interface Device (HID) Mode.

### Pairing Using Simple Serial Interface (SSI)

To pair the RS507, RS5100, or RS6000 with the device using SSI.

1. Swipe up from the bottom of the Home screen and touch .

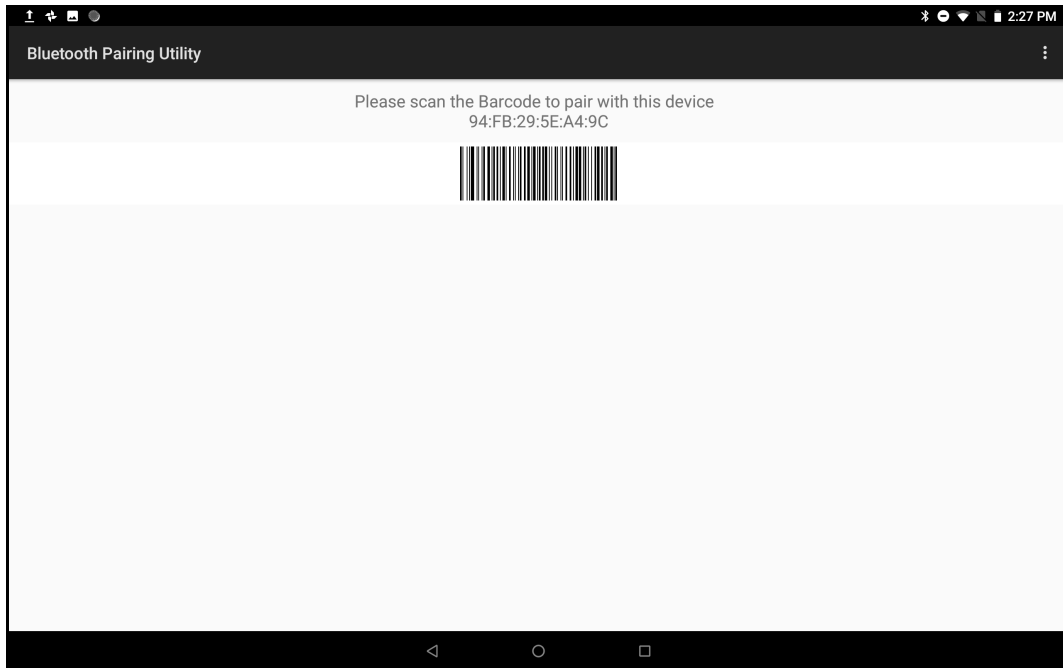

2. Using the ring scanner, scan the barcode on the screen.

The ring scanner emits a string of high/low/high/low beeps. The Scan LED flashes green indicating that the ring scanner is attempting to establish connection with the device. When connection is established, the Scan LED turns off and the ring scanner emits one string of low/high beeps.

A notification appears on the Notification panel and the  icon appears in the Status bar.

## Pairing Using Bluetooth Human Interface Device

To pair the ring scanner with the device using Human Interface Device (HID):

1. Ensure that Bluetooth is enabled on both devices.
2. Ensure that the Bluetooth device to discover is in discoverable mode.
3. Ensure that the two devices are within 10 meters (32.8 feet) of one another.
4. Place the ring scanner in HID mode. If the ring scanner is already in HID mode, skip to step 5.
  - a. Remove the battery from the ring scanner.
  - b. Press and hold the Restore key.
  - c. Install the battery onto the ring scanner.
  - d. Keep holding the Restore key for about five seconds until a chirp is heard and the Scan LEDs flash green.
  - e. Scan the barcode below to place the ring scanner in HID mode.

**Figure 23** RS507/RS507X Bluetooth HID Barcode



**Figure 24** RS5100/RS6000 Bluetooth HID Barcode

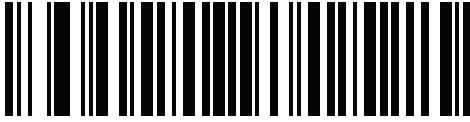

5. Remove the battery from the ring scanner.
6. Re-install the battery into the ring scanner.
7. Swipe down from the Status bar to open the Quick Access panel and then touch .
8. Touch **Bluetooth**.
9. Touch **Pair new device**. The device begins searching for discoverable Bluetooth devices in the area and displays them under **Available devices**.
10. Scroll through the list and select the ring scanner.

The device connects to the ring scanner and **Connected** appears below the device name. The Bluetooth device is added to the **Paired devices** list and a trusted (“paired”) connection is established.

A notification appears on Notification panel and the  icon appears in the Status bar.

## Pairing a Bluetooth Scanner

Connect the scanner to the device using one of the following methods:

- Simple Serial Interface (SSI) mode
- Bluetooth Human Interface Device (HID) mode.

### Pairing Using Simple Serial Interface

To pair the Bluetooth scanner with the device using SSI:

1. Ensure that the two devices are within 10 meters (32.8 feet) of one another.
2. Install the battery into the scanner.
3. On the device swipe up from the bottom of the Home screen and touch .
4. Using the scanner, scan the barcode on the screen.

The scanner emits a high/low/high/low beeps. The Scan LED flashes green indicating that the scanner is attempting to establish connection with the device. When connection is established, the Scan LED turns off and the scanner emits one string of low/high beeps.

5. On the device touch Home.

### Pairing Using Bluetooth Human Interface Device

To pair the Bluetooth scanner with the device using HID:

1. Remove the battery from the scanner.
2. Replace the battery.

3. After the scanner reboots, scan the barcode below to place the scanner in HID mode.



4. On the device, swipe down from the Status bar to open the Quick Access panel and then touch .
5. Touch **Bluetooth**.
6. Touch **Pair new device**. The device begins searching for discoverable Bluetooth devices in the area and displays them under **Available devices**.
7. Scroll through the list and select XXXXX xxxxxx, where XXXXX is the scanner and xxxxxx is the serial number.

The device connects to the scanner, the scanner beeps once and **Connected** appears below the device name. The Bluetooth device is added to the **Paired devices** list and a trusted (“paired”) connection is established.

## Connecting a USB Scanner

To connect a USB scanner, use one of the following methods:

- Simple Serial Interface (SSI) mode
- Human Interface Device (HID) mode.

### Connecting Using Simple Serial Interface

To connect a USB scanner using SSI mode:

1. Connect the scanner cable USB connector to the USB port of the device (using a third-party USC-A to USB-C adapter) or to a vehicle cradle. The scanner beeps.
2. Ensure that the scanner is in SSI mode. Refer to the Refer to the DS36X8 Product Reference Guide and scan the SSI Over USB CDC barcode.

### Connecting Using HID Mode

To connect a USB scanner using HID mode:

1. Connect the scanner cable USB connector to the USB port of the device (using a third-party USC-A to USB-C adapter) or to a vehicle cradle. The scanner beeps.
2. Ensure that the scanner is in HID mode. Refer to the Refer to the DS36X8 Product Reference Guide and scan the HID Keyboard barcode or perform a factory reset.

## DataWedge

DataWedge is a utility that adds advanced barcode scanning capability to any application without writing code. It runs in the background and handles the interface to built-in barcode scanners. The captured barcode data is converted to keystrokes and sent to the target application as if it was typed on the keypad.

DataWedge allows any app on the device to get data from input sources such as a barcode scanner, MSR, RFID, voice, or serial port and manipulate the data based on options or rules.

Configure DataWedge to:

- Provide data capture services from any app.
- Use a particular scanner, reader or other peripheral device.
- Properly format and transmit data to a specific app.

To configure DataWedge refer to [techdocs.zebra.com/datawedge/](http://techdocs.zebra.com/datawedge/).

## Enabling DataWedge

1. Swipe up from the bottom of the Home screen and touch .
2. Touch **:** > **Settings**.
3. Touch the **DataWedge enabled** checkbox. A blue checkmark appears in the checkbox indicating that DataWedge is enabled.
4. Touch the Home button.

## Disabling DataWedge

1. Touch **:**.
2. Touch **Settings**.
3. Touch **DataWedge enabled**.

The blue check disappears from the checkbox indicating that DataWedge is disabled.

## Supported Decoders



**NOTE:** DataWedge supports the decoders listed below but not all are validated on this device.

**Table 4** Supported Decoders

Decoders	Camera	Internal Imager SE4710	SE4750 Expansion Back	RS5100	RS6000	RS507/RS507X	DS2278	DS3678	DS8178
Australian Postal	O	O	O	O	O	O	O	O	O
Aztec	X	X	X	X	X	X	X	X	X
Canadian Postal	O	O	O	O	O	--	--	--	--
Chinese 2 of 5	O	O	O	O	O	O	O	O	O



**Table 4** Supported Decoders (Continued)

Decoders	Camera	Internal Imager SE4710	SE4750 Expansion Back	RS5100	RS6000	RS507/RS507X	DS2278	DS3678	DS8178
Codabar	X	X	X	X	X	X	X	X	X
Code 11	O	O	O	O	O	O	O	O	O
Code 128	X	X	X	X	X	X	X	X	X
Code 39	X	X	X	X	X	X	X	X	X
Code 93	O	O	O	O	O	O	O	O	O
Composite AB	O	O	O	O	O	O	O	O	O
Composite C	O	O	O	O	O	O	O	O	O
Discrete 2 of 5	O	O	O	O	O	O	O	O	O
Datamatrix	X	X	X	X	X	X	X	X	X
Dutch Postal	O	O	O	O	O	O	O	O	O
DotCode	X	O	N/A	O	O	O	O	O	O
EAN13	X	X	X	X	X	X	X	X	X
EAN8	X	X	X	X	X	X	X	X	X
Grid Matrix	O	O	O	O	O	O	O	O	O
GS1 DataBar	X	X	X	X	X	X	X	X	X
GS1 DataBar Expanded	X	X	X	X	X	X	X	X	X
GS1 DataBar Limited	O	O	O	O	O	O	O	O	O
GS1 Datamatrix	O	O	O	O	O	--	O	O	O
GS1 QRCode	O	O	O	O	O	--	O	O	O
HAN XIN	O	--	O	O	O	--	--	O	--
Interleaved 2 of 5	O	O	O	O	O	O	O	O	O
Japanese Postal	O	O	O	O	O	O	O	O	O
Korean 3 of 5	O	O	O	O	O	O	O	O	O
MAIL MARK	X	X	X	X	X	--	X	X	X
Matrix 2 of 5	O	O	O	O	O	O	O	O	O
Maxicode	X	X	X	X	X	X	X	X	X
MicroPDF	O	O	O	O	O	O	O	O	O

**Table 4** Supported Decoders (Continued)

Decoders	Camera	Internal Imager SE4710	SE4750 Expansion Back	RS5100	RS6000	RS507/RS507X	DS2278	DS3678	DS8178
MicroQR	O	O	O	O	O	O	O	O	O
MSI	O	O	O	O	O	O	O	O	O
PDF417	X	X	X	X	X	X	X	X	X
QR Code	X	X	X	X	X	X	X	X	X
Decoder Signature	O	O	O	O	O	O	O	--	--
TLC 39	O	O	O	O	O	O	O	O	O
Trioptic 39	O	O	O	O	O	O	O	O	O
UK Postal	O	O	O	O	O	O	O	O	O
UPCA	X	X	X	X	X	X	X	X	X
UPCE0	X	X	X	X	X	X	X	X	X
UPCE1	O	O	O	O	O	O	O	O	O
US4state	O	O	O	O	O	O	O	O	O
US4state FICS	O	O	O	O	O	O	O	O	O
US Planet	O	O	O	O	O	O	O	O	O
US Postnet	O	O	O	O	O	O	O	O	O

**Key**

X = Enabled

O = Disabled

-- = Not Supported

Touch the Back button to return to the previous screen.

# Wireless

This section provides information on the following wireless features:

- Wireless Wide Area Network (WWAN)
- Wireless Local Area Network (WLAN)
- Bluetooth
- Near Field Communications (NFC)

## Wireless Wide Area Networks



**NOTE:** ET56 only.

Use Wireless wide area networks (WWANs) to access data over a cellular network. This section provides information on:

- Sharing a data connection
- Monitoring data usage
- Changing Cellular Network settings

## Sharing the Mobile Data Connection

The **Tethering & Portable Hotspot** settings allows sharing the mobile data connection with a single computer via USB tethering or Bluetooth tethering. Share the data connection with up to eight devices at once, by turning it into a portable Wi-Fi hotspot. While the device is sharing its data connection, an icon displays at the top of the screen and a corresponding message appears in the notification list.

### Enabling USB Tethering



**NOTE:** USB tethering is not supported on computers running Mac OS. If the computer is running Windows or a recent version of Linux (such as Ubuntu), follow these instructions without any special preparation. If running a version of Windows that precedes Windows 7, or some other operating system, you may need to prepare the computer to establish a network connection via USB.

1. Connect the device to a host computer with the USB cable.
2. The notification **Charging this device via USB** appears in the Notifications panel.
3. Go to **Settings**.
4. Touch **Network & Internet**.

5. Touch **Hotspot & tethering**.
6. Touch the **USB tethering** switch to enable.

The host computer is now sharing the device's data connection.

To stop sharing the data connection, touch the **USB tethering** switch again or disconnect the USB cable.

## Enabling Bluetooth Tethering

Use Bluetooth tethering to share the data connection with a host computer.

Configure the host computer to obtain its network connection using Bluetooth. For more information, see the host computer's documentation.

1. Pair the device with the host computer.
2. Go to **Settings**.
3. Touch **Networking & Internet**.
4. Touch **Hotspot & tethering**.
5. Touch the **Bluetooth tethering** switch to enable.

The host computer is now sharing the device's data connection.

To stop sharing the data connection, touch the **Bluetooth tethering** switch again.

## Enabling Wi-Fi Hotspot

To enable the Wi-Fi Hotspot:

1. Go to **Settings**.
2. Touch **Network & Internet**.
3. Touch **Hotspot & tethering**.
4. Touch **Wi-Fi hotspot**.
5. Toggle the switch to enable.

After a moment, the device starts broadcasting its Wi-Fi network name (SSID). Connect to it with up to eight computers or other devices. The Hotspot (📶) icon appears in the Status bar.

To stop sharing the data connection, touch the toggle switch again.

## Configuring the Wi-Fi Hotspot

1. Go to **Settings**.
2. Touch **Network & Internet**.
3. Touch **Hotspot & tethering**.
4. Touch **Wi-Fi hotspot**.
5. In the **Hotspot name** text field, edit the name for the hotspot.
6. Touch **Security** and select a security method from the drop-down list.
  - **WPA2-Personal**
    - a. Touch **Hotspot password**.
    - b. Enter a password.
    - c. Touch **OK**.

- **None** - If **None** is selected in the Security option, a password is not required.
7. Touch **Advanced**.
  8. If desired, touch **Turn off hotspot automatically** to turn off Wi-Fi Hotspot when no devices are connected.
  9. In the **AP Band** drop-down list, select **2.4 GHz Band** or **5.0 GHz Band**.

## Data Usage

Data usage refers to the amount of data uploaded or downloaded by the device during a given period. Depending on the wireless plan, you may be charged additional fees when your data usage exceeds your plan's limit.

To monitor your data usage:

1. Go to **Settings**.
2. Touch **Network & internet > Mobile network > Data usage**.



**CAUTION:** The usage displayed on the data usage settings screen is measured by your device. Your carrier's data usage accounting may differ. Usage in excess of your carrier plan's data limits can result in steep overage charges. The feature described here can help you track your usage, but is not guaranteed to prevent additional charges.

Data usage settings allow:

- Enable Data Saver.
- Set the data usage warning level.
- Set a data usage limit.
- View or restrict data usage by app.
- Identify mobile hotspots and restrict background downloads that may result in extra charges.

By default, the data usage settings screen displays the mobile data settings. That is, the data network or networks provided by your carrier.

### Setting Data Usage Warning

To set a warning alert when the device has used a certain amount of mobile data:

1. Go to **Settings**.
2. Touch **Network & internet > Mobile network > Data usage > **.
3. If necessary, touch **Set data warning** to enable it.
4. Touch **Data warning**.
5. Enter a number. To switch between megabytes (MB) and gigabytes (GB), touch the down arrow.
6. Touch **SET**.

When the usage reaches the set level, a notification appears.

### Setting Data Limit

1. Go to **Settings**.
2. Touch **Network & internet > Mobile network > Data usage > **.
3. Touch **Set data limit**.

4. Touch **OK**.
5. Touch **Data limit**.
6. Enter a number. To switch between megabytes (MB) and gigabytes (GB), touch the down arrow.
7. Touch **Set**.

When the limit is reached, data automatically turns off and a notification appears.

## Cellular Network Settings

Cellular network settings applies to WWAN devices only.

### Data When Roaming

Roaming is disabled by default to prevent the device from transmitting data over other carriers' mobile networks when leaving an area that is covered by the carrier's networks. This is useful for controlling expenses if the service plan does not include data roaming.

#### Enabling Data on GSM Devices

1. Go to **Settings**.
2. Touch **Network & Internet > Mobile network**.
3. Touch **Roaming**.

The switch moves to the on position.

### Setting Preferred Network

Change the network operating mode.

1. Go to **Settings**.
2. Touch **Network & Internet > Mobile network > Advanced**.
3. Touch **Automatically select network**.
4. Touch **Network**.
5. In the **Available network** list, select a carrier network.

### Using Search for MicroCell

A MicroCell acts like a mini cell tower in a building or residence and connects to an existing broadband Internet service. It improves cell signal performance for voice calls, texts, and cellular data applications like picture messaging and Web surfing.

1. Go to **Settings**.
2. Touch **Network & Internet > Mobile network**.
3. Touch **Search for MicroCell**.

### Configuring the Access Point Name



**NOTE:** Many service provider Access Point Name (APN) data are pre-configured in the device. The APN information for all other service providers must be obtained from the wireless service provider.

To use the data on a network, configure the APN information.

1. Go to **Settings**.

2. Touch **Network & Internet > Mobile network > Advanced**.
3. Touch **Access Point Names**.
4. Touch an APN name in the list to edit an existing APN or touch **+** to create a new APN.
5. Touch each APN setting and enter the appropriate data obtained from the wireless service provider.
6. When finished, touch **:** > **Save**.
7. Touch the radio button next to the APN name to start using it.
8. Touch the Home button.

### Locking the SIM Card

Locking the SIM card requires the user to enter a PIN every time the device is turned on. If the correct PIN is not entered, only emergency calls can be made.

1. Go to **Settings**.
2. Touch **Security > SIM card lock**.
3. Touch **Lock SIM card**.
4. Enter the PIN associated with the card. Touch **OK**.
5. Reset the device.

## Wireless Local Area Networks

Wireless local area networks (WLANs) allow the device to communicate wirelessly inside a building. Before using the device on a WLAN, the facility must be set up with the required hardware to run the WLAN (sometimes known as infrastructure). The infrastructure and the device must both be properly configured to enable this communication.

Refer to the documentation provided with the infrastructure (access points (APs), access ports, switches, Radius servers, etc.) for instructions on how to set up the infrastructure.

Once the infrastructure is set up to enforce the chosen WLAN security scheme, use the **Wireless & networks** settings to configure the device to match the security scheme.

The device supports the following WLAN security options:

- None
- Enhanced Open
- Wireless Equivalent Privacy (WEP)
- Wi-Fi Protected Access (WPA)/WPA2 Personal (PSK)
- WPA3-Personal
- WPA/WPA2/WPA3 Enterprise (EAP)
  - Protected Extensible Authentication Protocol (PEAP) - with MSCHAPV2 and GTC authentication.
  - Transport Layer Security (TLS)
  - Tunneled Transport Layer Security (TTLS) - with Password Authentication Protocol (PAP), MSCHAP and MSCHAPv2 authentication
  - Password (PWD)
  - Lightweight Extensible Authentication Protocol (LEAP).

- WPA3-Enterprise 192-bit

The **Status** bar displays icons that indicate Wi-Fi network availability and Wi-Fi status.



**NOTE:** To extend the life of the battery, turn off Wi-Fi when not in use.

## Connecting to a Wi-Fi Network

To connect to a Wi-Fi network:

1. Go to **Settings**.
2. Touch **Wi-Fi** to open the **Wi-Fi** screen. The device searches for WLANs in the area and lists them.
3. Scroll through the list and select the desired WLAN network.
4. For open networks, touch profile once or press and hold and then select **Connect** or for secure networks enter the required password or other credentials then touch **Connect**. See the system administrator for more information.

The device obtains a network address and other required information from the network using the dynamic host configuration protocol (DHCP) protocol. To configure the device with a fixed internet protocol (IP) address, see [Configuring the Device to Use a Static IP Address on page 45](#).

5. In the Wi-Fi setting field, **Connected** appears indicating that the device is connected to the WLAN.

## Removing a Wi-Fi Network

To remove a remembered or connected network:

1. Go to **Settings**.
2. Touch **Network & Internet > Wi-Fi**.
3. Scroll down to the bottom of the list and touch **Saved networks**.
4. Touch the name of the network.
5. Touch **FORGET**.
6. Touch the Home button.

## WLAN Configuration

This section provides information on configuring Wi-Fi settings.

### Configuring a Secure Wi-Fi Network

1. Go to **Settings**.
2. Touch **Network & Internet > Wi-Fi**.
3. Slide the switch to the **ON** position.
4. The device searches for WLANs in the area and lists them on the screen.
5. Scroll through the list and select the desired WLAN network.
6. Touch the desired network. If the network security is **Open**, the device automatically connects to the network. For all other network security a dialog box appears.



7. If the network security is WPA/WPA2-Personal, WPA3-Personal, or WEP, enter the required password and then touch **Connect**.
8. If the network security is WPA/WPA2/WPA3 Enterprise:
  - Touch the **EAP method** drop-down list and select one of the following:
    - **PEAP**
    - **TLS**
    - **TTLS**
    - **PWD**
    - **LEAP**.
  - Touch the **Phase 2 authentication** drop-down list and select an authentication method.
  - If required, touch **CA certificate** and select a Certification Authority (CA) certificate. Note: Certificates are installed using the **Security** settings.
  - If required, touch **User certificate** and select a user certificate. Note: User certificates are installed using the Security settings.
  - If required, in the **Identity** text box, enter the username credentials.
  - If desired, in the **Anonymous identity** text box, enter an anonymous identity username.
  - If required, in the **Password** text box, enter the password for then given identity.
9. If the network security is **WPA3-Enterprise 192-bit**:
  - Touch **CA certificate** and select a Certification Authority (CA) certificate. Note: Certificates are installed using the **Security** settings.
  - Touch **User certificate** and select a user certificate. Note: User certificates are installed using the **Security** settings.
  - In the **Identity** text box, enter the username credentials.



**NOTE:** By default, the network Proxy is set to **None** and the IP settings is set to **DHCP**. See Configuring for a Proxy Server for setting connection to a proxy server and see Configuring the Device to Use a Static IP Address for setting the device to use a static IP address.

10. Touch **Connect**.
11. Touch the Home button.

## Manually Adding a Wi-Fi Network

Manually add a Wi-Fi network if the network does not broadcast its name (SSID) or to add a Wi-Fi network when out of range.

1. Go to **Settings**.
2. Touch **Network & Internet > Wi-Fi**.
3. Slide the Wi-Fi switch to the **On** position.
4. Scroll to the bottom of the list and select **Add network**.
5. In the **Network name** text box, enter the name of the Wi-Fi network.
6. In the **Security** drop-down list, set the type of security to:
  - **None**

- **Enhanced Open**
  - **WEP**
  - **WPA/WPA2-Personal**
  - **WPA3-Personal**
  - **WPA/WPA2/WPA3-Enterprise**
  - **WPA3-Enterprise 192-bit**
7. If the network security is **None** or **Enhanced Open**, touch **Save**.
  8. If the network security is **WEP**, **WPA3-Personal**, or **WPA/WPA2-Personal**, enter the required password and then touch **Save**.
  9. If the network security is **WPA/WPA2/WPA3-Enterprise**:
    - Touch the **EAP method** drop-down list and select one of the following:
      - **PEAP**
      - **TLS**
      - **TTLS**
      - **PWD**
      - **LEAP**.
    - Touch the **Phase 2 authentication** drop-down list and select an authentication method.
    - If required, touch **CA certificate** and select a Certification Authority (CA) certificate. Note: Certificates are installed using the **Security** settings.
    - If required, touch **User certificate** and select a user certificate. Note: User certificates are installed using the **Security** settings.
    - If required, in the **Identity** text box, enter the username credentials.
    - If desired, in the **Anonymous identity** text box, enter an anonymous identity username.
    - If required, in the **Password** text box, enter the password for the given identity.
  10. If the network security is **WPA3-Enterprise 192-bit**:
    - Touch **CA certificate** and select a Certification Authority (CA) certificate. Note: Certificates are installed using the **Security** settings.
    - Touch **User certificate** and select a user certificate. Note: User certificates are installed using the **Security** settings.
    - In the **Identity** text box, enter the username credentials.
-  **NOTE:** By default, the network Proxy is set to **None** and the IP settings is set to **DHCP**. See [Configuring for a Proxy Server on page 45](#) for setting connection to a proxy server and see [Configuring the Device to Use a Static IP Address on page 45](#) for setting the device to use a static IP address.
11. Touch **Save**. To connect to the saved network, touch and hold on the saved network and select **Connect to network**.
  12. Touch the Home button.

## Configuring for a Proxy Server

A proxy server is a server that acts as an intermediary for requests from clients seeking resources from other servers. A client connects to the proxy server and requests some service, such as a file, connection, web page, or other resource, available from a different server. The proxy server evaluates the request according to its filtering rules. For example, it may filter traffic by IP address or protocol. If the request is validated by the filter, the proxy provides the resource by connecting to the relevant server and requesting the service on behalf of the client.

It is important for enterprise customers to be able to set up secure computing environments within their companies, making proxy configuration essential. Proxy configuration acts as a security barrier ensuring that the proxy server monitors all traffic between the Internet and the intranet. This is normally an integral part of security enforcement in corporate firewalls within intranets.

1. Go to **Settings**.
2. Touch **Network & Internet > Wi-Fi**.
3. Slide the Wi-Fi switch to the **On** position.
4. In the network dialog box, select and touch a network.
5. Touch **Advanced options**.
6. Touch **Proxy** and select **Manual**.
7. In the **Proxy hostname** text box, enter the address of the proxy server.
8. In the **Proxy port** text box, enter the port number for the proxy server.
9. In the **Bypass proxy for** text box, enter addresses for web sites that are not required to go through the proxy server. Use a comma “,” between addresses. Do not use spaces or carriage returns between addresses.
10. Touch **Connect**.
11. Touch the Home button.

## Configuring the Device to Use a Static IP Address

By default, the device is configured to use Dynamic Host Configuration Protocol (DHCP) to assign an Internet protocol (IP) address when connecting to a wireless network.

1. Go to **Settings**.
2. Touch **Network & Internet > Wi-Fi**.
3. Slide the Wi-Fi switch to the **On** position.
4. In the network dialog box, select and touch a network.
5. Touch **Advanced options**.
6. Touch **IP settings** and select **Static**.
7. In the **IP address** text box, enter an IP address for the device.
8. If required, in the **Gateway** text box, enter a gateway address for the device.
9. If required, in the **Network prefix length** text box, enter the prefix length.
10. If required, in the **DNS 1** text box, enter a Domain Name System (DNS) address.
11. If required, in the **DNS 2** text box, enter a DNS address.
12. Touch **Connect**.

13. Touch the Home button.

## Wi-Fi Preferences

Use the **Wi-Fi preferences** to configure advanced Wi-Fi settings. From the Wi-Fi screen scroll down to the bottom of the screen and touch **Wi-Fi preferences**.

- **Turn on Wi-Fi automatically** - When enabled, Wi-Fi automatically turns back on when near high quality saved networks.
- **Open network notification** - When enabled, notifies the user when an open network is available.
- **Advanced** - Touch to expand options.
  - **Additional settings** - See Additional Settings.
  - **Install Certificates** – Touch to install certificates.
  - **Network rating provider** - Disabled (AOSP devices). To help determine what constitutes a good Wi-Fi network, Android supports external Network rating providers that provide information about the quality of open Wi-Fi networks. Select one of the providers listed or **None**. If none are available or selected, the Connect to open networks feature is disabled.
  - **Wi-Fi Direct** - Displays a list of devices available for a direct Wi-Fi connection.
  - **MAC address** - Displays the Media Access Control (MAC) address of the device when connecting to Wi-Fi networks.
  - **IP address** - Displays the IP address of the device when connecting to Wi-Fi networks.

## Additional Wi-Fi Settings



**NOTE:** Additional Wi-Fi settings are for the device, not for a specific wireless network.

Use the **Additional Settings** to configure additional Wi-Fi settings. To view the additional Wi-Fi settings, scroll to the bottom of the **Wi-Fi** screen and touch **Wi-Fi Preferences > Advanced > Additional settings**.

- **Regulatory**
  - **Country Selection** - Displays the acquired country code if 802.11d is enabled, else it displays the currently selected country code.
  - **Region code** - Displays the current region code.
- **Band and Channel Selection**
  - **Wi-Fi frequency band** - Set the frequency band to: **Auto** (default), **5 GHz only** or **2.4 GHz only**.
  - **Available channels (2.4 GHz)** - Touch to display the **Available channels** menu. Select specific channels and touch **OK**.
  - **Available channels (5 GHz)** - Touch to display the **Available channels** menu. Select specific channels and touch **OK**.
- **Logging**
  - **Advanced Logging** – Touch to enable advanced logging or change the log directory.
  - **Wireless logs** - Use to capture Wi-Fi log files.
    - **Fusion Logger** - Touch to open the **Fusion Logger** application. This application maintains a history of high level WLAN events which helps to understand the status of connectivity.

- **Fusion Status** - Touch to display live status of WLAN state. Also provides information about the device and connected profile.
- **About**
  - **Version** - Displays the current Fusion information.

### Wi-Fi Direct

Wi-Fi Direct devices can connect to each other without having to go through an access point. Wi-Fi Direct devices establish their own ad-hoc network when required, letting you see which devices are available and choose which one you want to connect to.

1. Go to **Settings**.
2. Touch **Wi-Fi > Wi-Fi preferences > Advanced > Wi-Fi Direct**. The device begins searching for another Wi-Fi Direct device.
3. Under **Peer devices**, touch the other device name.
4. On the other device, select **Accept**.

**Connected** appears on the device. On both devices, in their respective Wi-Fi Direct screens, the other device name appears in the list.

### Bluetooth

Bluetooth devices can communicate without wires, using frequency-hopping spread spectrum (FHSS) radio frequency (RF) to transmit and receive data in the 2.4 GHz Industry Scientific and Medical (ISM) band (802.15.1). Bluetooth wireless technology is specifically designed for short-range (10 m (32.8 ft)) communication and low power consumption.

Devices with Bluetooth capabilities can exchange information (for example, files, appointments, and tasks) with other Bluetooth enabled devices such as printers, access points, and other mobile devices.

The device supports Bluetooth Low Energy. Bluetooth Low Energy is targeted at applications in the healthcare, fitness, security, and home entertainment industries. It provides reduced power consumption and cost while maintaining standard Bluetooth range.

### Adaptive Frequency Hopping

Adaptive Frequency Hopping (AFH) is a method of avoiding fixed frequency interferers, and can be used with Bluetooth voice. All devices in the piconet (Bluetooth network) must be AFH-capable in order for AFH to work. There is no AFH when connecting and discovering devices. Avoid making Bluetooth connections and discoveries during critical 802.11b communications. AFH for Bluetooth consists of four main sections:

- **Channel Classification** - A method of detecting an interference on a channel-by-channel basis, or pre-defined channel mask.
- **Link Management** - Coordinates and distributes the AFH information to the rest of the Bluetooth network.
- **Hop Sequence Modification** - Avoids interference by selectively reducing the number of hopping channels.
- **Channel Maintenance** - A method for periodically re-evaluating the channels.

When AFH is enabled, the Bluetooth radio “hops around” (instead of through) the 802.11b high-rate channels. AFH coexistence allows enterprise devices to operate in any infrastructure.



**NOTE:** It is not recommended to perform Bluetooth wireless technology inquiry when high rate 802.11b operation is required.

## Security

The current Bluetooth specification defines security at the link level. Application-level security is not specified. This allows application developers to define security mechanisms tailored to their specific need. Link-level security occurs between devices, not users, while application-level security can be implemented on a per-user basis. The Bluetooth specification defines security algorithms and procedures required to authenticate devices, and if needed, encrypt the data flowing on the link between the devices. Device authentication is a mandatory feature of Bluetooth while link encryption is optional.

Pairing of Bluetooth devices is accomplished by creating an initialization key used to authenticate the devices and create a link key for them. Entering a common personal identification number (PIN) in the devices being paired generates the initialization key. The PIN is never sent over the air. By default, the Bluetooth stack responds with no key when a key is requested (it is up to user to respond to the key request event). Authentication of Bluetooth devices is based-upon a challenge-response transaction. Bluetooth allows for a PIN or passkey used to create other 128-bit keys used for security and encryption. The encryption key is derived from the link key used to authenticate the pairing devices. Also worthy of note is the limited range and fast frequency hopping of the Bluetooth radios that makes long-distance eavesdropping difficult.

Recommendations are:

- Perform pairing in a secure environment
- Keep PIN codes private and do not store the PIN codes in the device
- Implement application-level security.

## Bluetooth Profiles

The device supports the Bluetooth services listed.

**Table 5** Bluetooth Profiles

Profile	Description
Service Discovery Protocol (SDP)	Handles the search for known and specific services as well as general services.
Serial Port Profile (SPP)	Allows use of RFCOMM protocol to emulate serial cable connection between two Bluetooth peer devices. For example, connecting the device to a printer.
Object Push Profile (OPP)	Allows the device to push and pull objects to and from a push server.
Advanced Audio Distribution Profile (A2DP)	Allows the device to stream stereo-quality audio to a wireless headset or wireless stereo speakers.
Audio/Video Remote Control Profile (AVRCP)	Allows the device to control A/V equipment to which a user has access. It may be used in concert with A2DP.
Personal Area Network (PAN)	Allows the use of Bluetooth Network Encapsulation Protocol to provide L3 networking capabilities over a Bluetooth link. Only PANU role is supported.
Human Interface Device Profile (HID)	Allows Bluetooth keyboards, pointing devices, gaming devices and remote monitoring devices to connect to the device.

**Table 5** Bluetooth Profiles (Continued)

Profile	Description
Headset Profile (HSP)	Allows a hands-free device, such as a Bluetooth headset, to place and receive calls on the device.
Hands-Free Profile (HFP)	Allows car hands-free kits to communicate with the device in the car.
Phone Book Access Profile (PBAP)	Allows exchange of Phone Book Objects between a car kit and a mobile device to allow the car kit to display the name of the incoming caller; allow the car kit to download the phone book so you can initiate a call from the car display.
Out of Band (OOB)	Allows exchange of information used in the pairing process. Pairing is completed using the Bluetooth radio, but requires information from the OOB mechanism. Using OOB with NFC enables pairing when devices simply get close, rather than requiring a lengthy discovery process.
Out of Band (OOB)	Allows exchange of information used in the pairing process. Pairing is initiated by NFC but completed using the Bluetooth radio. Pairing requires information from the OOB mechanism. Using OOB with NFC enables pairing when devices simply get close, rather than requiring a lengthy discovery process.
Symbol Serial Interface (SSI)	Allows for communication with Bluetooth Imager.
File Transfer Profile (FTP)	Provides the capability to browse, manipulate and transfer files in file system of another system. Uses GOEP as a basis.
Generic Attribute Profile (GATT)	Provides profile discovery and description services for Bluetooth Low Energy protocol. It defines how attributes are grouped together into sets to form services.
HID Over GATT Profile (HOGP)	Defines the procedures and features used by Bluetooth low energy HID Devices using GATT and Bluetooth HID Hosts using GATT.
Generic Access Profile (GAP)	Use for device discovery and authentication.
Object EXchange (OBEX)	Facilitates the exchange of binary objects between devices.

## Bluetooth Power States

The Bluetooth radio is off by default.

- Suspend - When the device goes into suspend mode, the Bluetooth radio stays on.
- Airplane Mode - When the device is placed in Airplane Mode, the Bluetooth radio turns off. When Airplane mode is disabled, the Bluetooth radio returns to the prior state. When in Airplane Mode, the Bluetooth radio can be turned back on if desired.

## Bluetooth Radio Power

Turn off the Bluetooth radio to save power or if entering an area with radio restrictions (for example, an airplane). When the radio is off, other Bluetooth devices cannot see or connect to the device. Turn on the Bluetooth radio to exchange information with other Bluetooth devices (within range). Communicate only with Bluetooth radios in close proximity.



**NOTE:** To achieve the best battery life, turn off radios when not in use.

## Enabling Bluetooth

1. Swipe down from the Status bar to open the Notification panel.
2. Touch  to turn Bluetooth on.
3. Touch the Home button.

## Disabling Bluetooth

1. Swipe down from the Status bar to open the Notification panel.
2. Touch  to turn Bluetooth off.
3. Touch the Home button.

## Discovering Bluetooth Device(s)

The device can receive information from discovered devices without pairing. However, once paired, the device and a paired device exchange information automatically when the Bluetooth radio is on.

1. Ensure that Bluetooth is enabled on both devices.
2. Ensure that the Bluetooth device to discover is in discoverable mode.
3. Ensure that the two devices are within 10 meters (32.8 feet) of one another.
4. Swipe down from the Status bar to open the Quick Access panel.
5. Touch and hold **Bluetooth**.
6. Touch **Pair new device**. The device begins searching for discoverable Bluetooth devices in the area and displays them under **Available devices**.
7. Scroll through the list and select a device. The Bluetooth pairing request dialog box appears.
8. Touch **Pair** on both devices.
9. The Bluetooth device is added to the **Paired devices** list and a trusted (“paired”) connection is established.

## Changing the Bluetooth Name

By default, the device has a generic Bluetooth name that is visible to other devices when connected.

1. Go to **Settings**.
2. Touch **Connected devices > Connection preferences > Bluetooth**.
3. If Bluetooth is not on, move the switch to turn Bluetooth on.
4. Touch **Device name**.
5. Enter a name and touch **RENAME**.
6. Touch the Home button.

## Connecting to a Bluetooth Device

Once paired, connect to a Bluetooth device.

1. Go to **Settings**.
2. Touch **Connected devices > Connection preferences > Bluetooth**.



3. In the list, touch the unconnected Bluetooth device.

When connected, **Connected** appears below the device name.

## Selecting Profiles on the Bluetooth Device

Some Bluetooth devices have multiple profiles.

1. Go to **Settings**.
2. Touch **Connected devices > Connection preferences > Bluetooth**.
3. In the **Paired Devices** list, touch  next to the device name.
4. Turn on or off a profile to allow the device to use that profile.
5. Touch the Home button.

## Unpairing a Bluetooth Device

Unpairing a Bluetooth device erases all pairing information.

1. Go to **Settings**.
2. Touch **Connected devices > Connection preferences > Bluetooth**.
3. In the **Paired Devices** list, touch  next to the device name.
4. Touch **FORGET**.
5. Touch the Home button.

## Cast

Use **Cast** to mirror the device screen on a Miracast enabled wireless display.

1. Go to **Settings**.
2. Touch **Connected devices > Connection preferences > Cast**.
3. Touch  > **Enable wireless display**.  
The device searches for nearby Miracast devices and lists them.
4. Touch a device to begin casting.
5. Touch the Home button.

## Near Field Communications

NFC/HF RFID is a short-range wireless connectivity technology standard that enables secure transaction between a reader and a contactless smartcard. The technology is based on ISO/IEC 14443 type A and B (proximity), ISO/IEC 15693 (vicinity), and FeliCa standards, using the HF 13.56 MHz unlicensed band.

The device supports the following operating modes:

- Reader mode
- Peer-to-Peer communication
- Card Emulation mode.

Using NFC, the device can:

- Read contactless cards such as contactless tickets, ID cards and ePassport.
- Read and write information to contactless cards such as SmartPosters and tickets, as well as devices with NFC interface such as vending machines.
- Read information from supported medical sensors.
- Pair with supported Bluetooth devices such as printers , ring scanners (ex. RS6000), and headsets (ex. HS3100).
- Exchange data with another NFC device.
- Emulate contactless card such as payment, or ticket.

The device NFC antenna is positioned to read NFC cards from the top of the device while the device is being held.

## Reading NFC Cards

Read contactless cards using NFC.

**Figure 25** Reading Cards

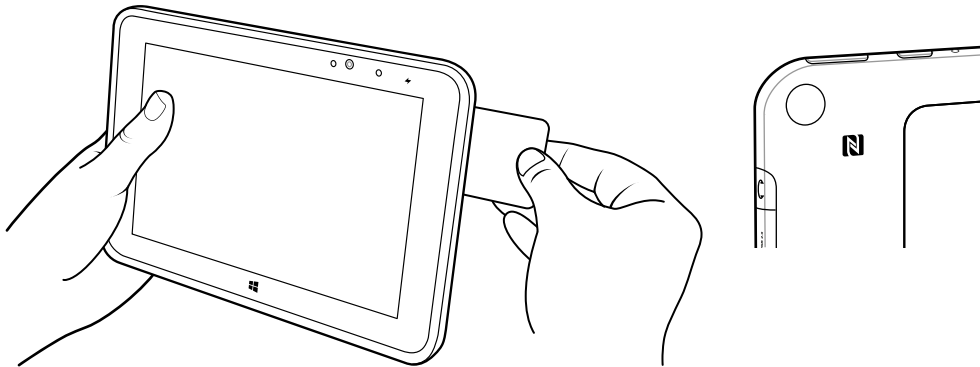

1. Launch an NFC enabled application.
2. Hold device as shown.
3. Move the device close to the NFC card until it detects the card.
4. Hold the card steadily until the transaction is complete (usually indicated by the application).

## Enterprise NFC Settings

Improve NFC performance or increase battery life by selecting which NFC features to use on the device.

- **Card Detection Mode** - Select a card detection mode.
  - **Low** - Increases battery life by lowering the NFC detection speed.
  - **Hybrid** - Provides a balance between NFC detection speed and battery life (default).
  - **Standard** - Provides the best NFC detection speed, but reduces battery life.
- **Supported Card Technology** - Select an option to detect only one NFC tag type, increasing battery life, but reducing detection speed.
  - **All (Default)** - Detects all NFC tag types.

- **ISO 14443 Type A/B**
- **FeliCa**
- **ISO15693**
- **Other NFC settings available with Zebra administrator tools (CSP)** - Allows configuration of additional Enterprise NFC Settings through staging tools and Mobile Device Management (MDM) solutions with an MX version that supports the Enterprise NFC Settings Configuration Service Provider (CSP). For more information on using the Enterprise NFC Settings CSP, refer to: [techdocs.zebra.com](https://techdocs.zebra.com).

# Accessories

## Introduction

The device accessories provide a variety of product support capabilities.

**Table 6** Device Accessories

Accessory	Part Number	Description
<b>Cradles</b>		
Charge Only Cradle	CRD-ET5X-1SCG2	Charges the main battery and optional Power Pack installed in the Expansion Back. Requires power supply PWR-BGA12V50W0WW, DC line cord CBL-DC-388A1-01 and country-specific AC line cord.
Communication and Charging Cradle	CRD-ET5X-1SCOM1	Charges the main battery and optional Power Pack installed in the Expansion Back. Requires power supply PWR-BGA12V50W0WW, DC line cord CBL-DC-388A1-01, and country-specific AC line cord.
Rugged Communication and Charging Cradle	CRD-ET5X-1SCOM2R	Charges the main battery and optional Power Pack installed in the Expansion Back. Supports rugged frame and rugged IO Adapter. Requires power supply PWR-BGA12V50W0WW, DC line cord CBL-DC-388A1-01, and country-specific AC line cord.
4-Slot Charge Only Cradle	CRD-ET5X-SE4CO2-01	Charges up to four main batteries and optional Power Pack installed in the Expansion Back and up to four Power Packs in the optional 4-Slot Battery Charger. Requires power supply PWR-BGA12V108W0WW, DC line cord CBL-DC-388A1-01, and country-specific AC line cord.

## Accessories

**Table 6** Device Accessories (Continued)

Accessory	Part Number	Description
<b>Chargers</b>		
Power Supply	PWR-BGA12V108W0WW	Provides power to the 4-Slot Charge Only Cradle.
Power Supply	PWR-BGA12V50W0WW	Provides power to the Charge Only Cradle, Communication and Charging Cradle, Rugged Communication and Charging Cradle, and 4-Slot Battery Charger for Optional Battery Power Pack.
Power Supply	PWR-WUA5V12W0xx Where xx: AR = Argentina AU = Australia BR = Brazil CN = China EU = European Union Countries GB = Great Britain IN = India KR = Korea US = United States	Provides power to the tablet using the USB-C cable CBL-TC2X-USBC-01.
4-Slot Battery Charger	SAC-ET5X-4PPK1-01	Chargers up to four Power Packs. Requires power supply PWR-BGA12V50W0WW, DC Line cord CBL-DC-388A1-01, and country-specific AC line cord.
Rugged Charge Connector	CHG-ET5X-CBL2-01	Charges the main battery and optional Power Pack installed in the Expansion Back. Requires power supply PWR-BGA12V50W0WW, DC Line Cord CBL-DC-388A1-01 and country-specific AC line cord.
<b>Miscellaneous</b>		
Replacement 8.4 in. Internal Battery	BTRY-ET5X-8IN5-01	Replacement battery for 8.4 in. tablet.
Replacement 10.1 in. Internal Battery	BTRY-ET5X-10IN5-01	Replacement battery for 10.1 in. tablet.
Replacement 8.4 in. Battery Cover	KT-ET5X-8BTDR2-01	Replacement battery cover for 8.4 in. tablet.
Replacement 10.1 in. Battery Cover	KT-ET5X-10BTDR2-01	Replacement battery cover for 10.1 in. tablet.
8.4 in. Rugged Frame with IO Adapter	SG-ET5X-8RCSE2-02	Add extra protection for the 8.4 in. tablet and IO Adapter for connection to the Rugged Communication and Charging Cradle.

**Table 6** Device Accessories (Continued)

Accessory	Part Number	Description
10.1" Rugged Frame with IO Adapter	SG-ET5X-10RCSE2-01	Add extra protection for the 10.1 in. tablet and IO Adapter for connection to the Rugged Communication and Charging Cradle.
Replacement Rugged IO Connector	SG-ET5X-RGIO2-01	Replacement rugged IO connector for the Rugged Frames.
8.4 in. SE4750 Expansion Back	ZBK-ET5X-8SCN5-01	Provides data capture using the SE4750 scan engine, rotating hand strap and slot for optional Power Pack.
8.4 in. Expansion Back	ZBK-ET5X-8RH1-01	Provides rotating hand strap and slot for optional Power Pack.
10.1" SE4750 Expansion Back	ZBK-ET5X-10SCN5-01	Provides data capture using the SE4750 scan engine, rotating hand strap and slot for optional Power Pack.
10.1" Expansion Back	ZBK-ET5X-10RH1-01	Provides rotating hand strap and slot for optional Power Pack.
Power Pack	BTRY-ET5X-PRPK1-01	Provides additional power for charging the device battery using an Expansion Back.
Passive Stylus	SG-TC7X-STYLUS-03	Provides easy writing, drawing, and navigation and accuracy with the thin tip and hovering capabilities.
Replacement Expansion Back Hand Strap	SG-ET5X-RHTP1-01	Replacement hands strap for Expansion Backs.
Coiled Stylus Tether	SG-ET5X-SLTETR-01	Secures a stylus to the hand strap.
8.4 in. Operations Case	SG-ET5X-8HLST-01	Provides carrying solution for 8.4 in. tablet.
10.1" Operations Case	SG-ET5X-10HLST-01	Provides carrying solution for 10.1 in. tablet.
Breakaway Shoulder Strap	SG-ET5X-SHDRSTP-01	Use with the Operations Case and D-clips to carry tablet on shoulder.

## Battery Charging

### Main Battery Charging

The 8.4 in. tablet main battery charges from fully depleted to 90% in approximately 2 hours and from fully depleted to 100% in approximately 3 hours.

The 10.1 in. tablet main battery charges from fully depleted to 90% in approximately 3 hours and from fully depleted to 100% in approximately 5 hours.



**NOTE:** The Charging indicator only illuminates when the device is connected to AC power.

**Table 7** Charging Indicator

LED	Indication
Off	Device is not in cradle; not seated properly; or cradle is not powered.
Blinking Amber	Device is charging.
Green	Charging complete.
Red	Error in charging; check placement of the device.

## Charging Temperature

Charge batteries in ambient temperatures from 0°C to +40°C (32°F to 104°F) as reported by the battery. Charging is intelligently controlled by the charger. To accomplish this, for small periods of time, the charger alternately enables and disables battery charging to keep the battery at acceptable temperatures.

## Charge Only Cradle



**CAUTION:** Ensure that you follow the guidelines for battery safety described in [Battery Safety Guidelines](#) on page 113.



**NOTE:** The Charge Only Cradle (CRD-ET5X-1SCG2) comes with two inserts; tall insert and short insert. Install the tall insert when using a device without a Rugged Frame or Expansion Back. Install the short insert when using with an Expansion Back and without a Rugged Frame.

The Charge Only Cradle does not support the ET51 Enterprise Tablet with Integrated Scanner.

This section describes how to use a Charge Only Cradle with the device.

The Charge Only Cradle:

- Provides power for operating the device.
- Charges the device's battery and optional Power Pack installed in an Expansion Back.

**Figure 26** Charge Only Cradle - Front View

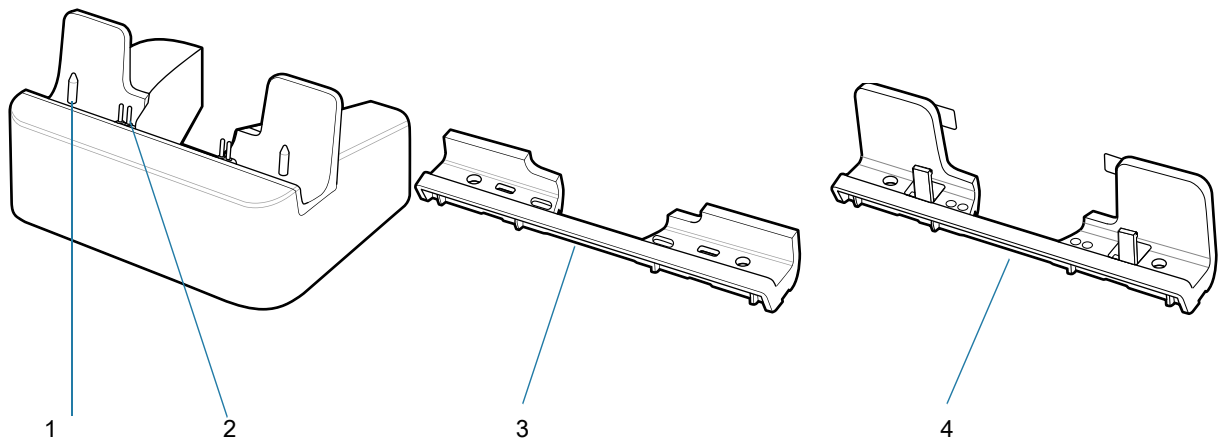

1	Guide pins
2	Charging pins
3	Short insert
4	Tall insert

**Figure 27** Charge Only Cradle - Rear View

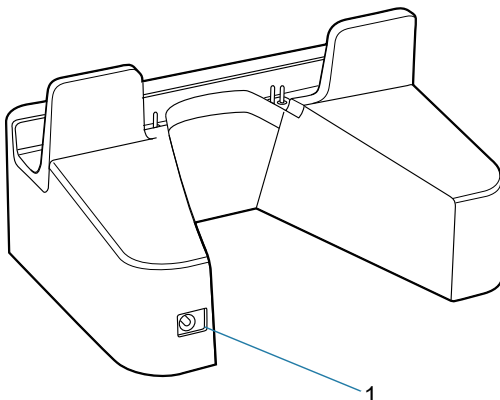



1	Power input
---	-------------

## Installing the Short Insert

Install the short insert when using an device with an Expansion Back and without a Rugged Frame.

1. Align the insert over the pins.

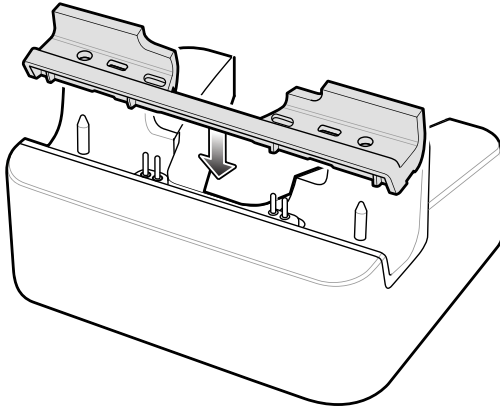

2. Press the insert down until it seats flush in the cradle.

## Installing the Tall Insert

Install the tall insert when using an device without an Expansion Back and Rugged Frame.

1. Peel the tape off the back of the insert.
2. Align the tall insert over the pins.

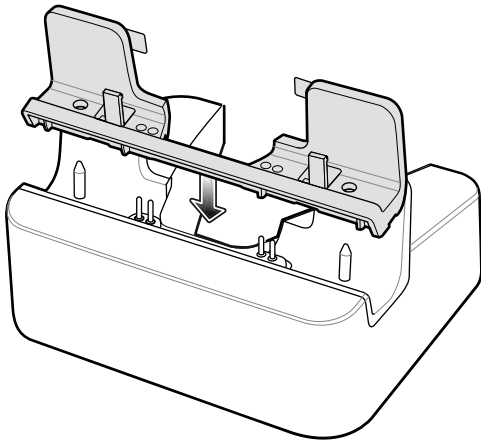

3. Press the insert down until it seats flush in the cradle.

4. Press the tabs against the cradle to secure the insert to the cradle.

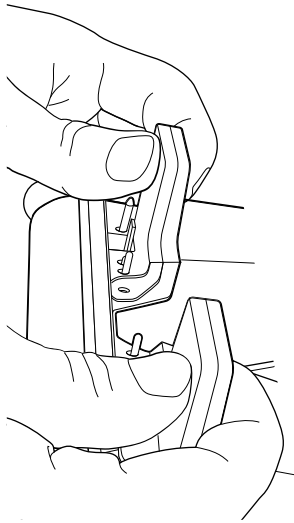

### Charging the Device

To charge the device in the Charge Only Cradle:

1. Align the device with the alignment pins on the cradle.
2. Insert the device into the cradle.



**NOTE:** Ensure the tablet is flat on the cradle and all charging contacts are touching the charging base.

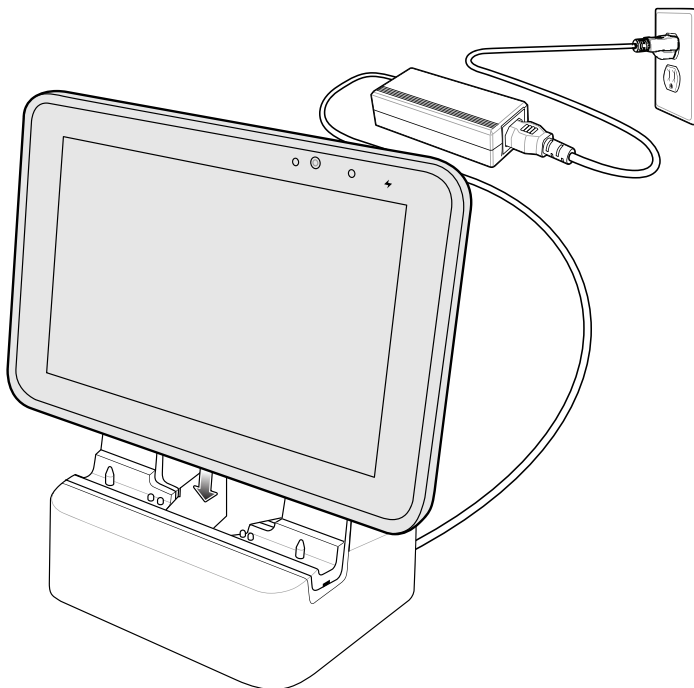

3. The device Charging LED indicates charging.

4. To remove the device from the Charge Only Cradle, hold the cradle down with one hand and lift the device.

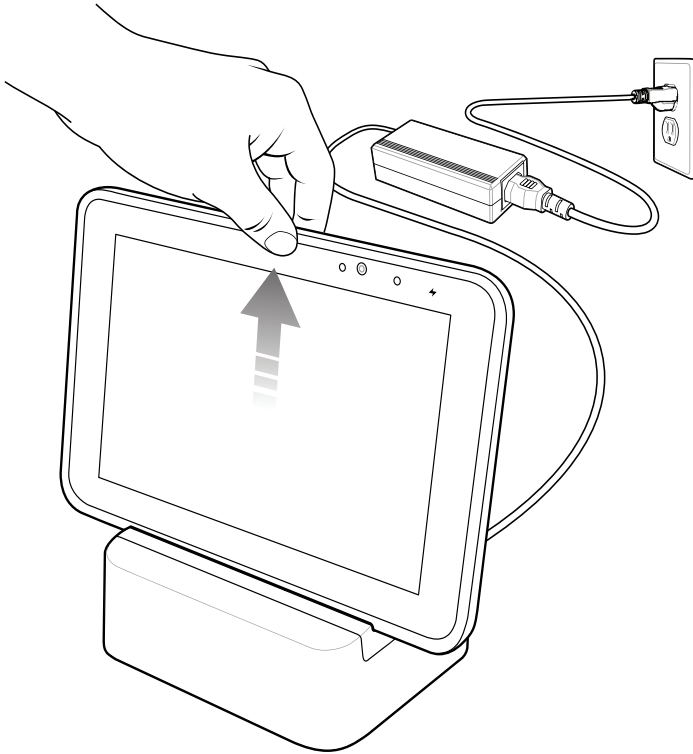

## Communication and Charging Cradle



**CAUTION:** Ensure that you follow the guidelines for battery safety described in [Battery Safety Guidelines](#) on page 113.



**NOTE:** The Communication and Charging Cradle (CRD-ET5X-1SCOM2) comes with two inserts; tall insert and short insert. Install the tall insert when using without a Rugged Frame or Expansion Back. Install the short insert when using with an Expansion Back and without a Rugged Frame.

The Communication and Charging Cradle does not support the ET51 Enterprise Tablet with Integrated Scanner.

This section describes how to use a Communication and Charging Cradle with the tablet.

The Communication and Charging cradle:

- Provides power for operating the tablet.
- Provides ports for connecting USB devices to the tablet, video output and connection to a LAN.
- Charges the tablet's battery and optional Power Pack installed in an Expansion Back.

**Figure 28** Communication and Charging Cradle - Front View

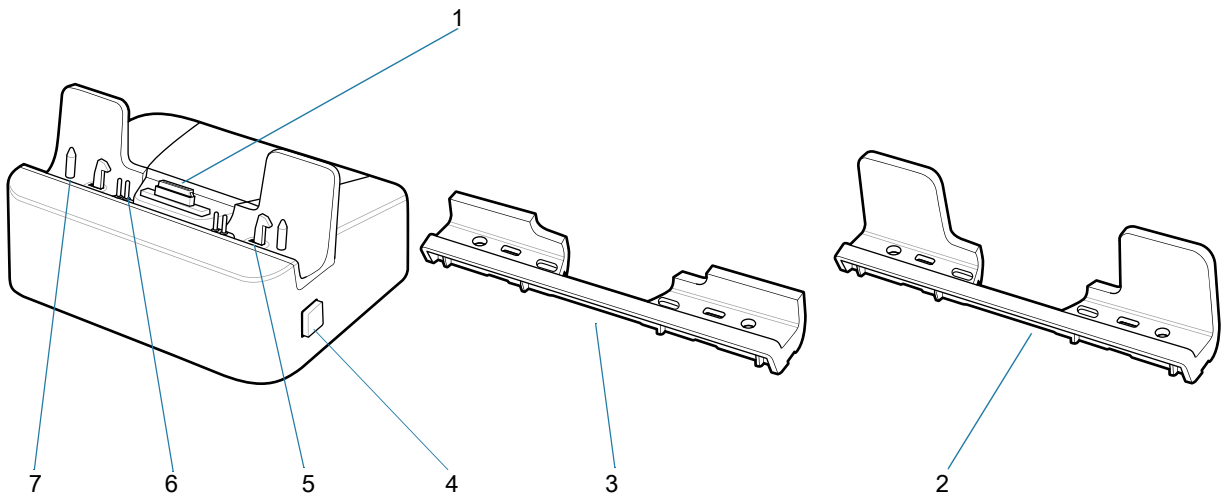

1	Docking connector
2	Tall insert
3	Short insert
4	Release button
5	Locking latches
6	Charging pins
7	Guide pins

**Figure 29** Communication and Charging Cradle - Rear View

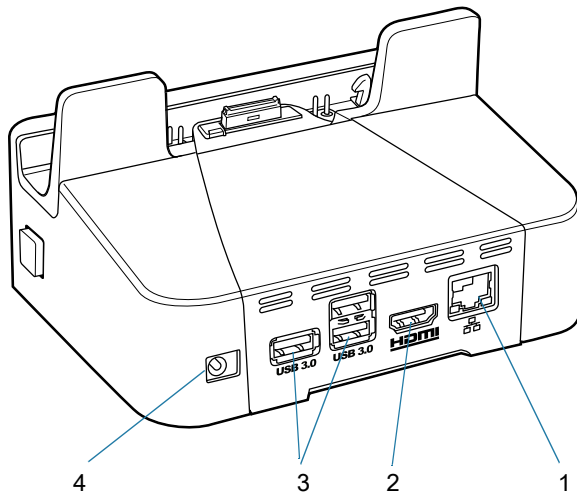

1	LAN (RJ45) port
2	HDMI port
3	USB 3.0 ports
4	Power input

**Figure 30** Communication and Charging Cradle - Setup

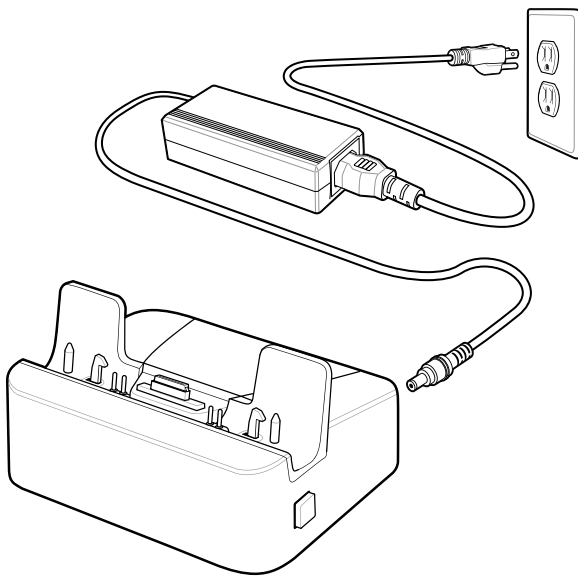

## Installing the Insert

Install the tall insert when using a device without a Rugged Frame or Expansion Back. Install the short insert when using a device with an Expansion Back and without a Rugged Frame.

1. Align the insert over the pins.

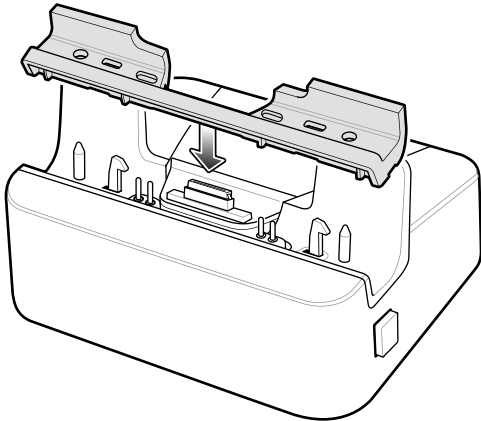

2. Press the insert down until it seats flush in the cradle.

## Charging the Device

To charge the device in the Communication and Charging Cradle:

1. Open the bottom access door and hold it to the back of the tablet.
2. Align the device with the alignment pins on the cradle.
3. Insert the device into the cradle. Note that the Communication and Charging Cradles contains a locking mechanism that locks the device to the cradle.



**NOTE:** Ensure the tablet is flat on the cradle and all charging contacts are touching the charging base.

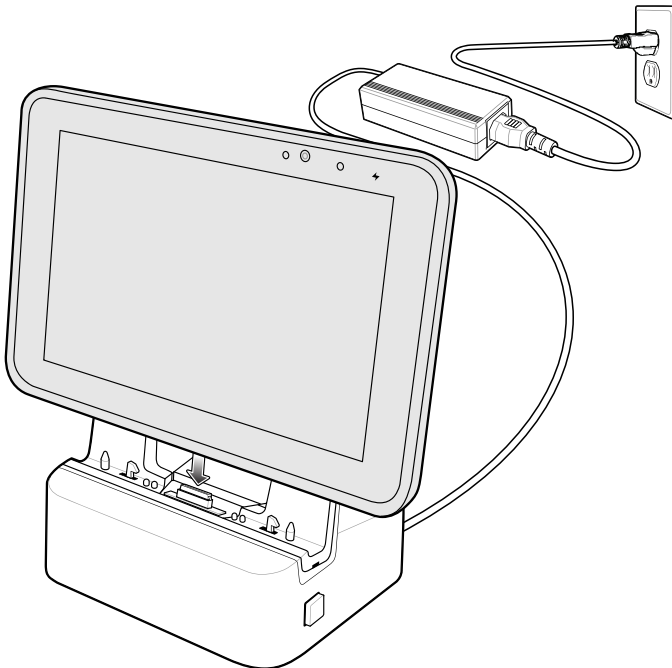

4. The device Charging LED indicates charging.

5. To remove the device from the Communication and Charging Cradle, press the release button on the right side of the cradle and lift the device. Use thumb to hold down the cradle.

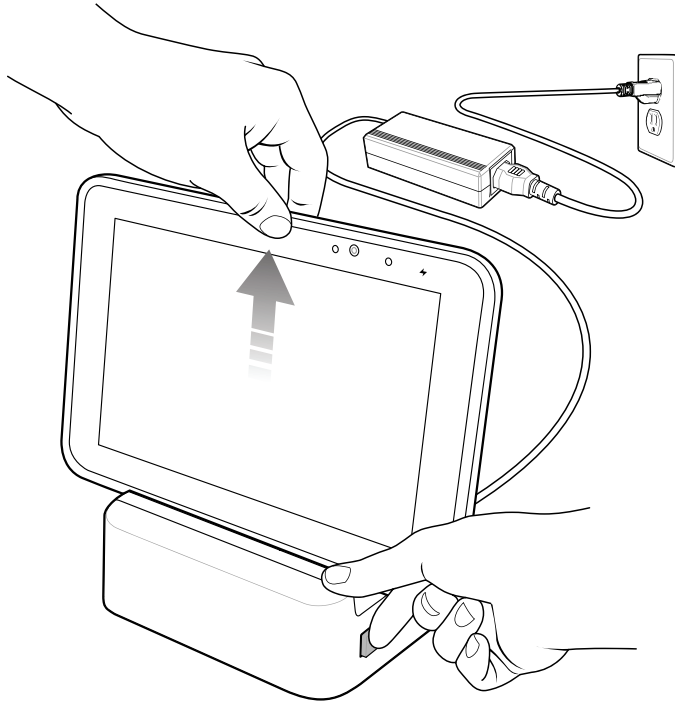

## Rugged Communication and Charging Cradle



**CAUTION:** Ensure that you follow the guidelines for battery safety described in [Battery Safety Guidelines](#) on page 113.

This section describes how to use a Rugged Communication and Charging Cradle with the device.

The Rugged Communication and Charging cradle:

- Provides power for operating the device.
- Provides ports for connecting USB devices to the tablet, video output and connection to a LAN.
- Charges the device's battery and optional Power Pack installed in an Expansion Back.
- Support the ET51 Enterprise Tablet with Integrated Scanner.

**Figure 31** Rugged Communication and Charging Cradle - Front View

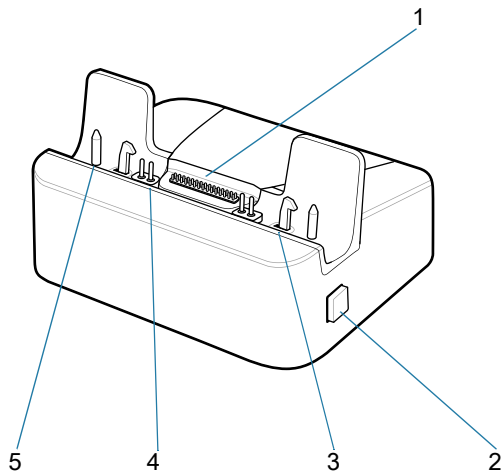

1	Rugged docking connector
2	Release button
3	Locking latches
4	Charging pins
5	Guide pins



**Figure 32** Rugged Communication and Charging Cradle - Rear View

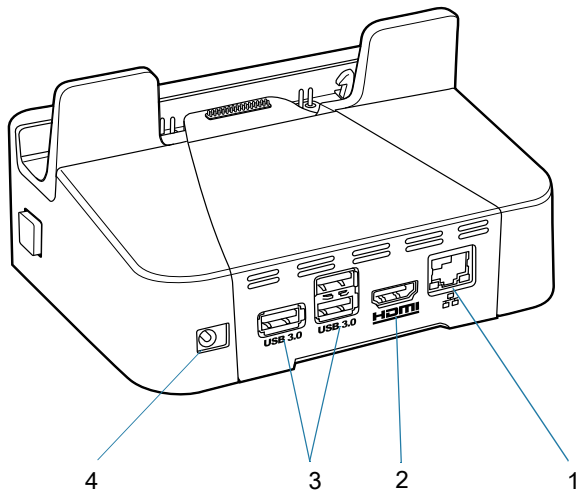

1	LAN (RJ45) port
2	HDMI port
3	USB 3.0 ports
4	Power input

For the ET51 Enterprise Tablet with Integrated Scanner, ensure that the cradle pads are installed prior to inserting the device into the cradle.

**Figure 33** Install Pads onto Cradle

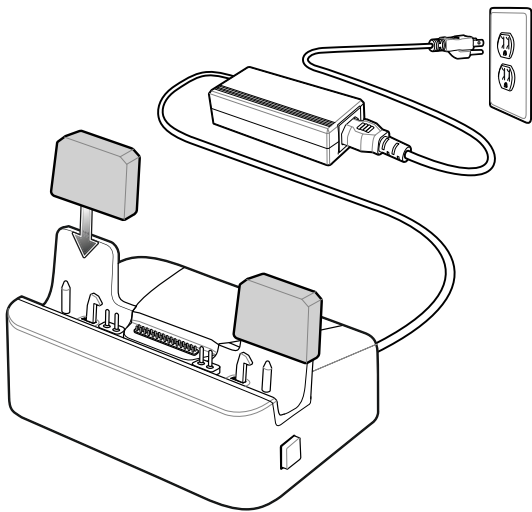

## Charging the Device

To charge the device using the Rugged Communication and Charging Cradle:

1. Align the device with the alignment pins on the cradle.
2. Insert the device into the cradle. Note that the Rugged Communication and Charging Cradles contains a locking mechanism that locks the device to the cradle.



**NOTE:** Ensure the tablet is flat on the cradle and all charging contacts are touching the charging base.

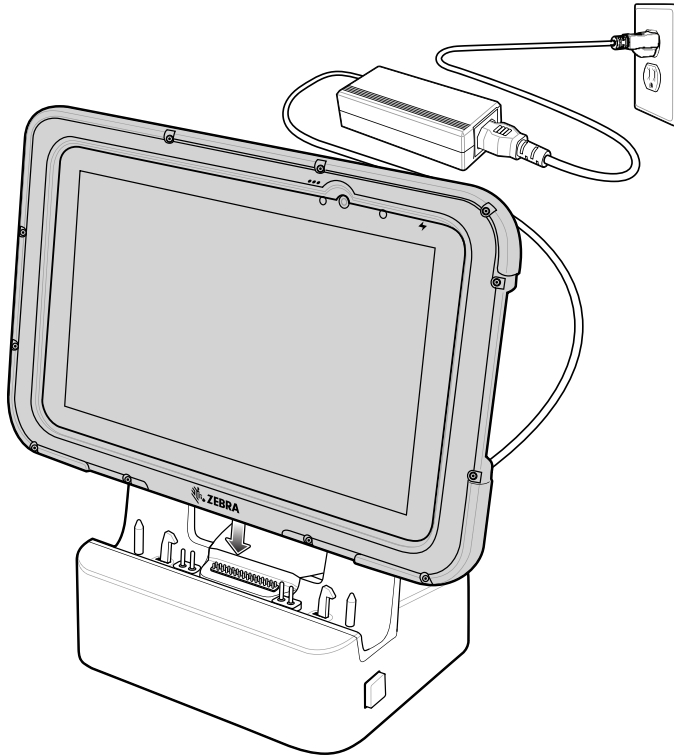

3. The device Charging LED indicates charging.
4. To remove the device from the Rugged Communication and Charging Cradle, press the release button on the right side of the cradle and lift the device. Use thumb to hold down the cradle.

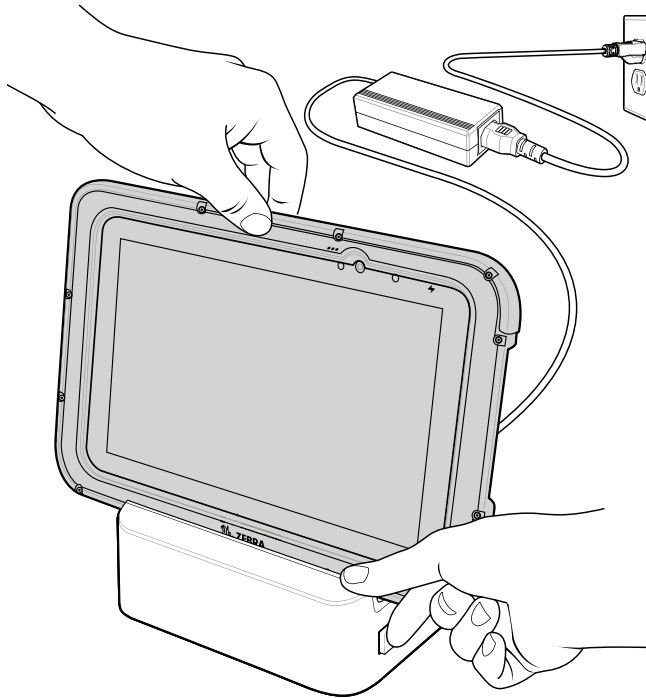

## 4-Slot Charge Only Cradle



**CAUTION:** Ensure that you follow the guidelines for battery safety described in [Battery Safety Guidelines](#) on page 113.

- Provides 5 VDC power for operating the device.
- Simultaneously charges up to four devices and up to four Power Packs using the optional Battery Charger Adapter.

**Figure 34** 4-Slot Charge Only Cradle

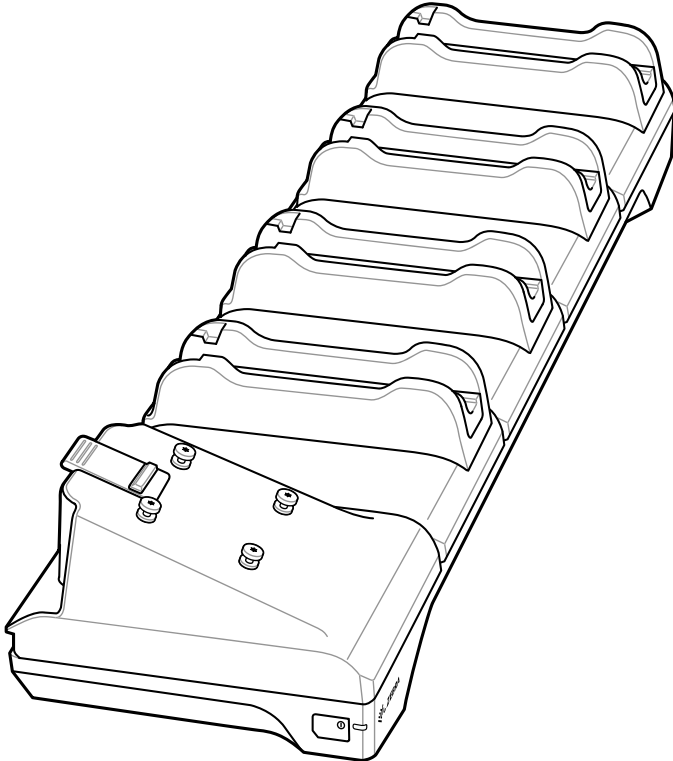

## Power Setup

Figure 35 Power Setup with Optional Charger

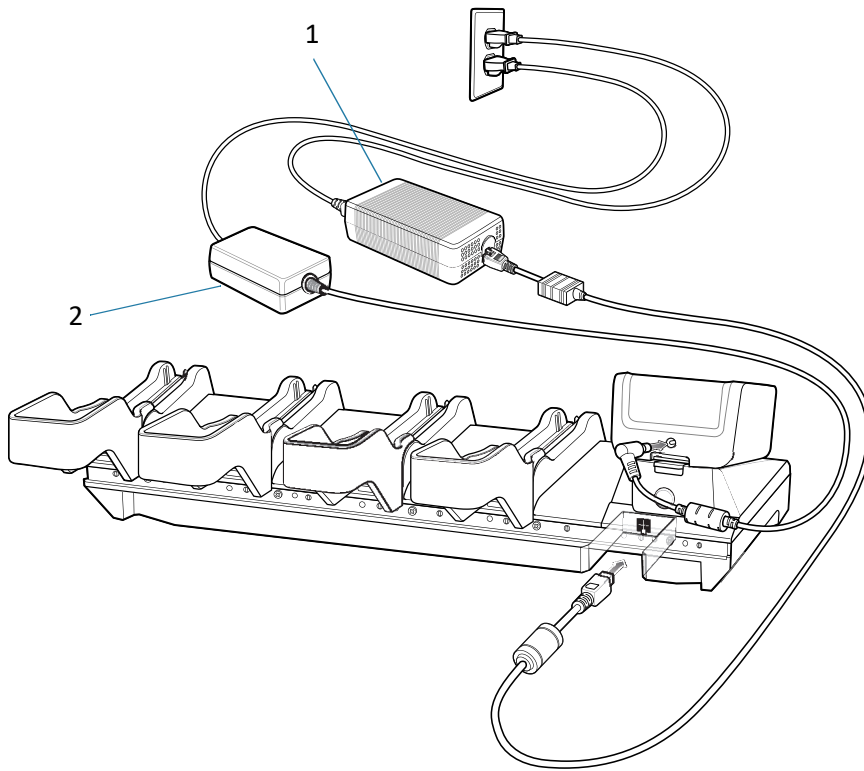

1	PWR-BGA12V108W0WW
2	PWR-BGA12V50W0WW

## Insert Installation

Install inserts into slots for device tablets without Rugged Frame.

**Figure 36** Install Insert in Slot

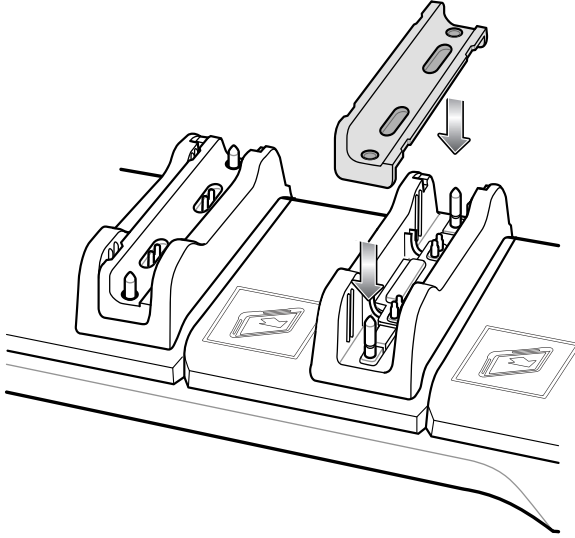

## Guide Installation

The cradle comes with four 8 in. tablets guide and four 10 in. tablet guides. Install the appropriate guides for the tablets.

1. Align the two tabs on the guide with the two slots in the cradle.

**Figure 37** Align Guide with Slot

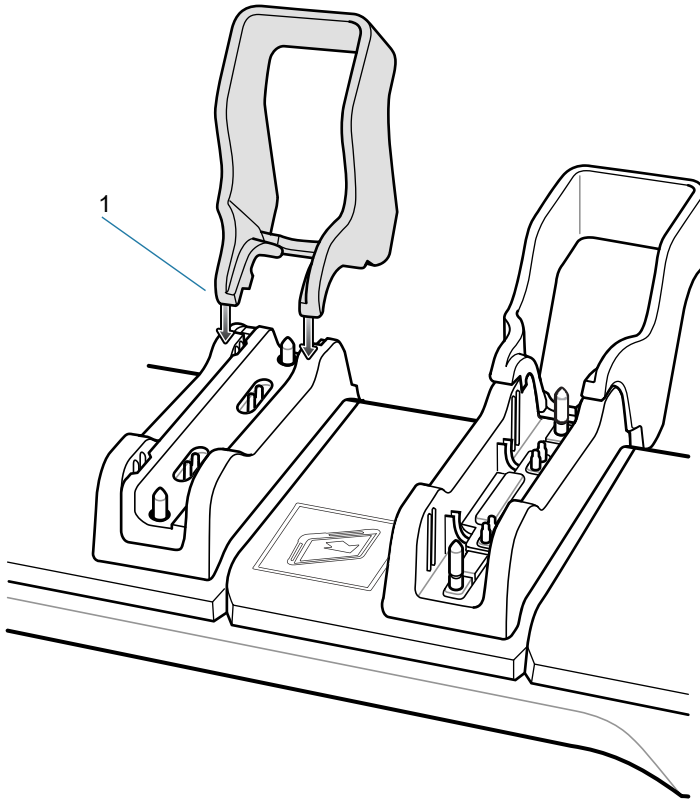

1	Guide tab
---	-----------

2. Place the guide down onto the cradle and then rotate the guide until it snaps into the cradle.

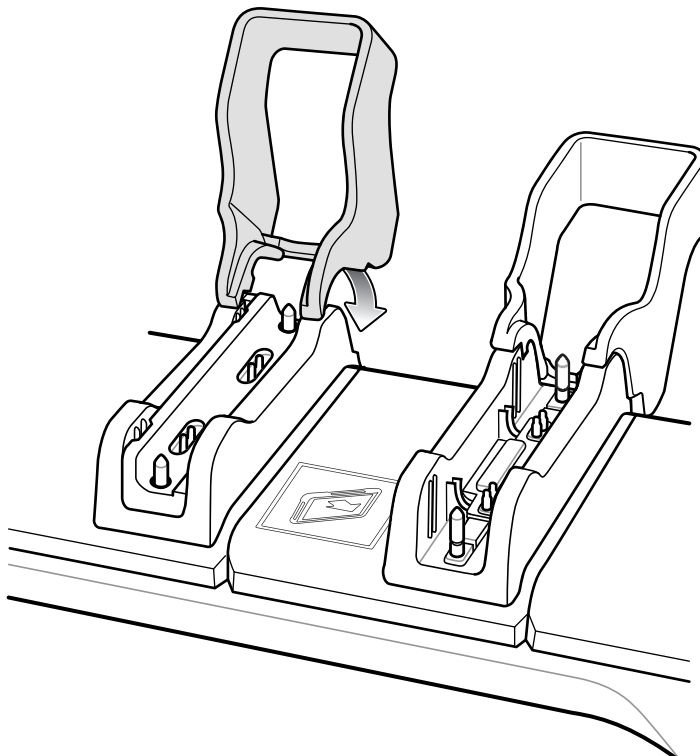

## Battery Charger Installation

Install optional 4-Slot Battery Charger onto cradle:

1. Align the mounting holes on the bottom of the charger with the four studs on the cradle.

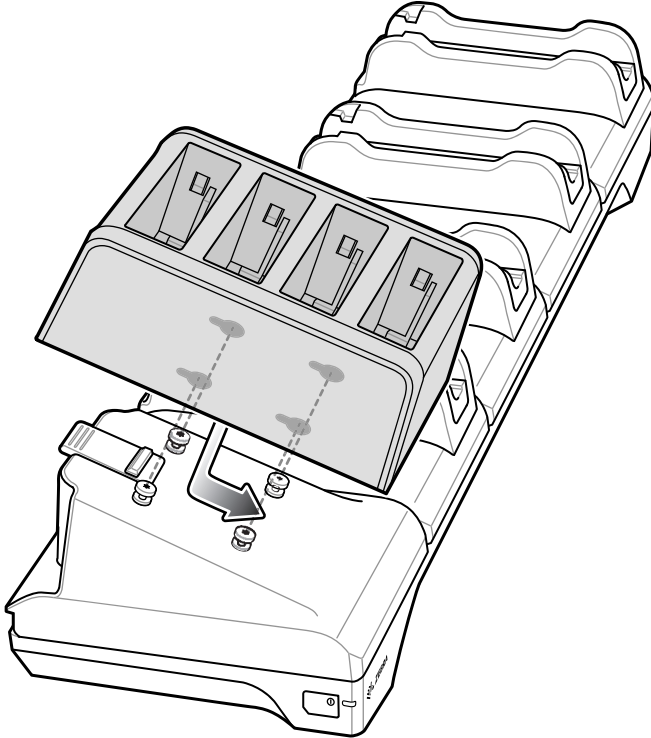

2. Place the charger on the cradle and then slide toward the front of the cradle.

## Insert Tablet into Slot

### Device without Rugged Frame

1. Install insert into slot.

2. Align the two alignment holes on the bottom of the tablet with the two alignment pins in the slot.

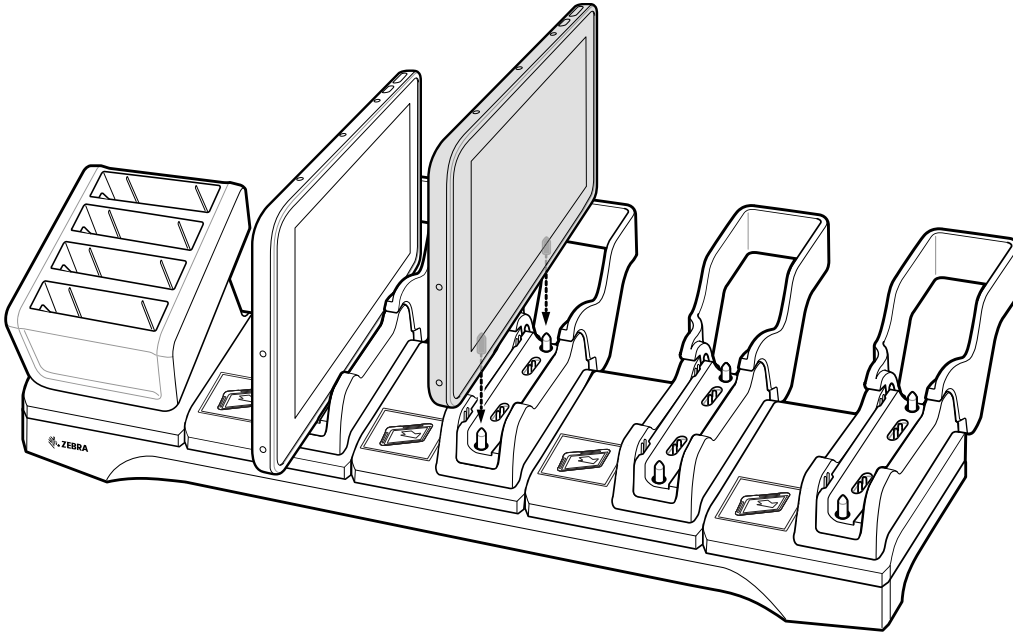

3. Place the device down into the slot with display facing away from Battery Charger.



**NOTE:** There are rubs on the insert that prevent the tablet from being inserted in the wrong orientation.

### Device with Rugged Frame

1. If applicable, remove insert from slot.
2. Slide device over slot into it touches the guide.

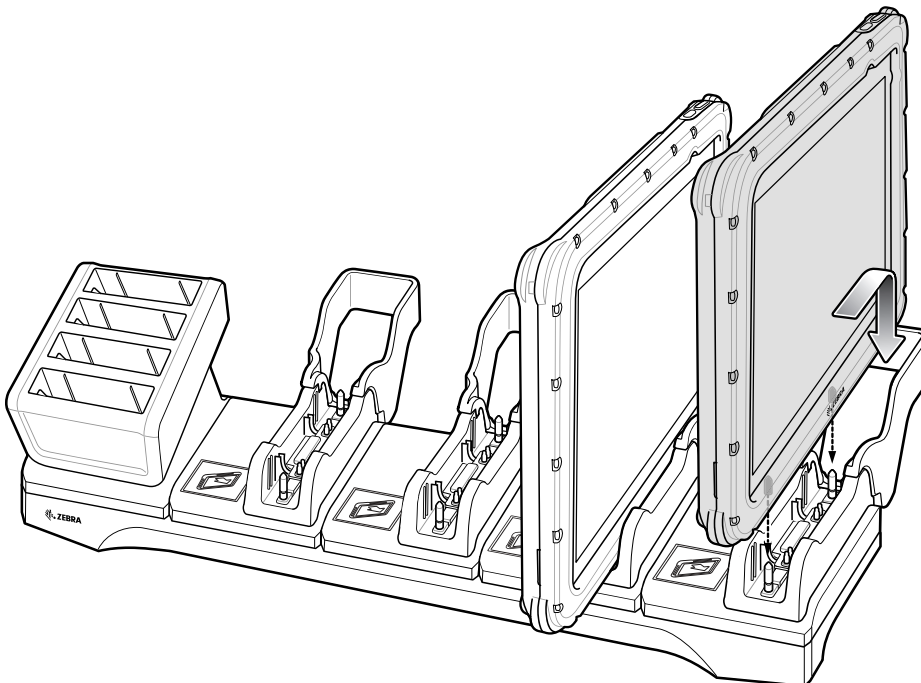

3. Place the device down into the slot with display facing away from Battery Charger.





**NOTE:** There are rubs on the slot that prevent the tablet from being inserted in the wrong orientation.

## Battery Charger Installation

Install optional 4-Slot Battery Charger onto cradle:

1. Align the mounting holes on the bottom of the charger with the four studs on the cradle.

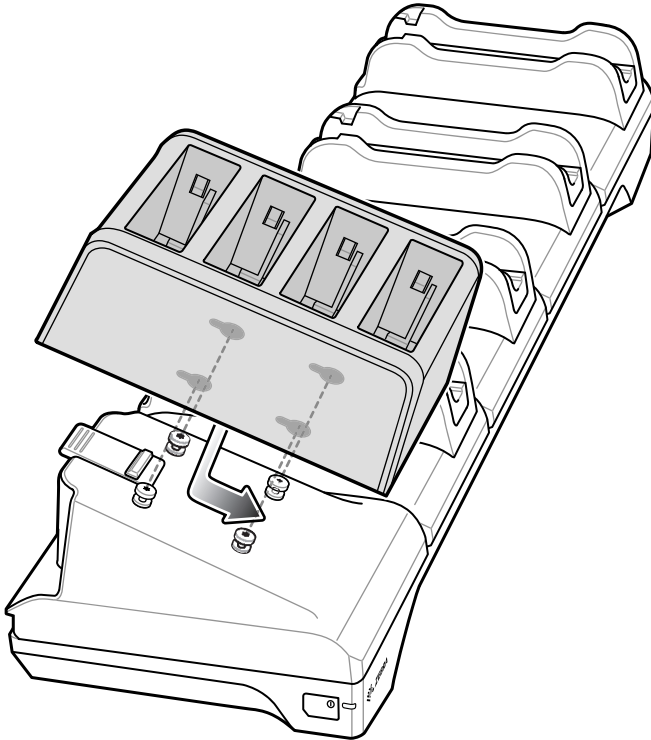

2. Place the charger on the cradle and then slide toward the front of the cradle.

## Rugged Charge Connector



**CAUTION:** Ensure that you follow the guidelines for battery safety described in [Battery Safety Guidelines](#) on page 113.

Use the Rugged Charge Connector to charge an device tablet.



**NOTE:** The Rugged Charge Connector does not support the ET51 Enterprise Tablet with Integrated Scanner.

The Rugged Connector does not support the ET51 Enterprise Tablet with Integrated Scanner.

**Figure 38** Rugged Charge Connector

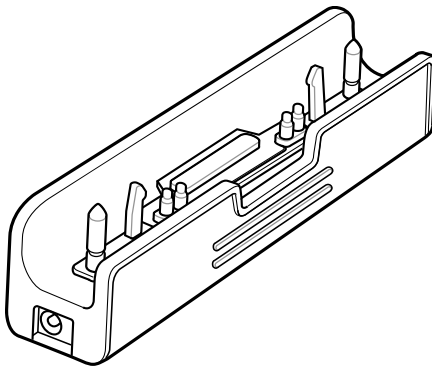

1. Align the pins in the Rugged Charge Connector with the slots in the device.

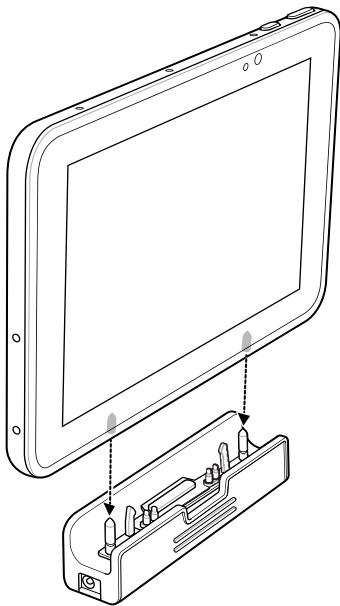

2. Plug the Power Supply connector into the Power Input Port on the Rugged Charge Connector.

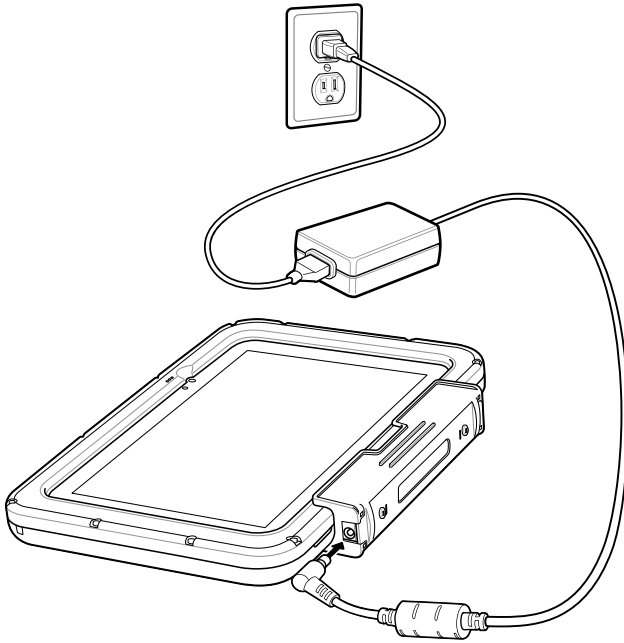

## Power Pack

The optional Power Pack provides additional power for charging the main battery.

**Figure 39** Power Pack

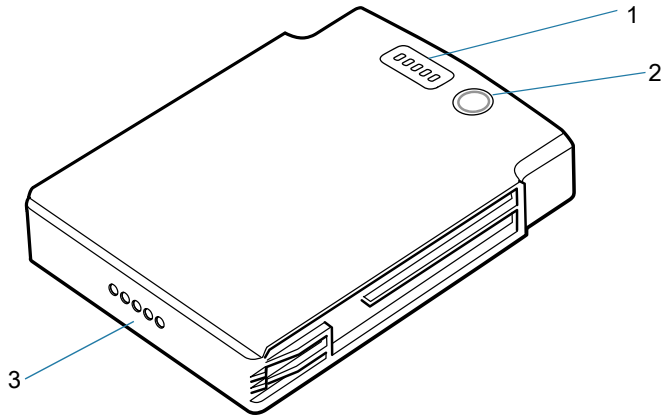

1	Charge level indicators
2	Charge indicator button
3	Power output contacts

1. Install one of the optional Expansion Backs. See [Expansion Back on page 85](#) for more information.
2. Press the two release buttons on the side of the Expansion Back. The dummy battery insert ejects slightly.

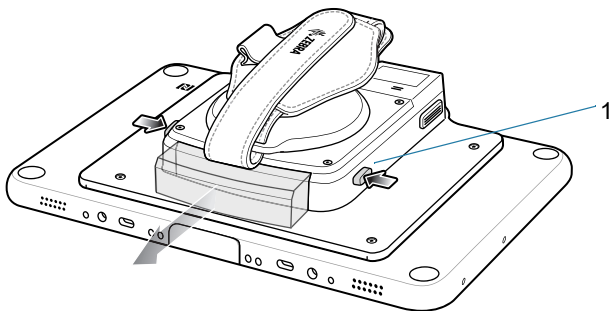

1	Release button (2)
---	--------------------

3. Remove dummy battery insert.

4. Insert Power Pack into slot until it snaps into place.

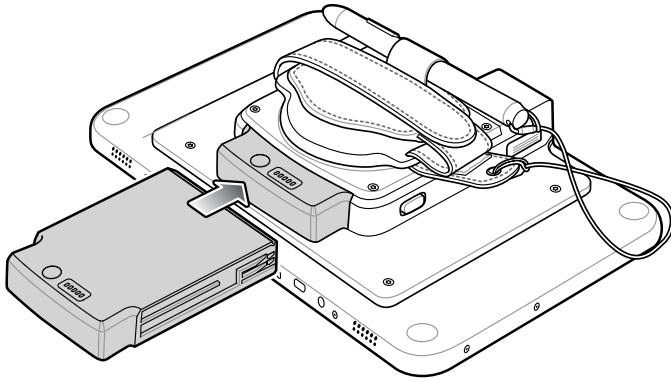

### Charging the Power Pack

Charge the Power Pack using:

- A cradle
- 4-Slot Charger.

### Using Cradle

With the Power Pack installed in an Expansion Back, place the device into a cradle. The Power Pack charges in less than 3.5 hours.

## Using the 4-Slot Battery Charger



**CAUTION:** Ensure that you follow the guidelines for battery safety described in [Battery Safety Guidelines](#) on page 113.

Use the 4-Slot Battery Charger to charge up to four Power Packs.

**Figure 40** 4-Slot Battery Charger

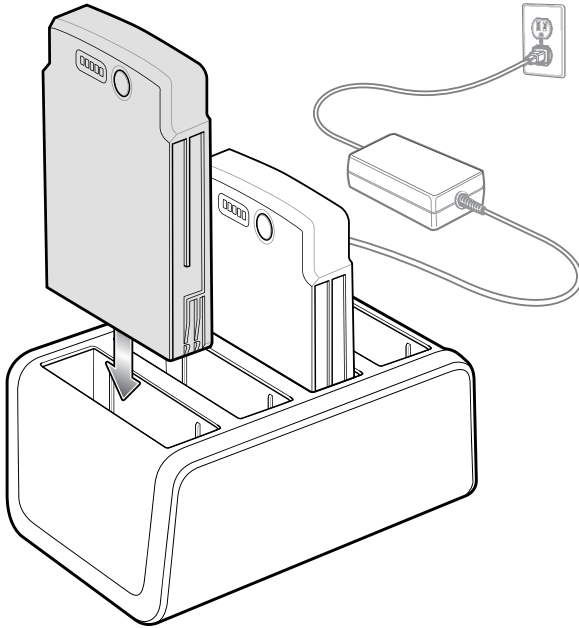

## Charging the Power Pack

Charge Power Packs in ambient temperatures from 0°C to +40°C (32°F to 104°F) as reported by the Power Pack. Charging is intelligently controlled by the charger. To accomplish this, for small periods of time, the charger alternately enables and disables Power Pack charging to keep the battery at acceptable temperatures.





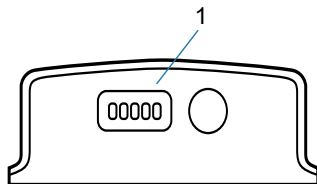



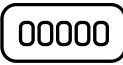

The Power Pack charge LED shows the status of the battery charging. The Power Pack charges in less than three hours. When charging, the Charge LEDs indicate the charge level.

**Figure 41** Power Pack Charge LEDs

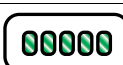
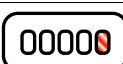

1	Charge level indicators
---	-------------------------

**Table 8** Power Pack Charge Status Indicators

Power Pack Indicators	Description
	Power not applied to Power Pack.
	Charge level is between 0% and 20%.
	Charge level is between 20% and 40%.
	Charge level is between 40% and 60%.
	Charge level is between 60% and 80%.
	Charge level is between 80% and 100%.
	Fully charged.
	Charging error.
	Solid Green LED
	Blinking Green LED
	Blinking Red LED

## Rugged Frame

The Rugged Frame (8.4 in. and 10.1 in.) adds additional protection to the device. Use the Rugged I/O Adapter when docking the device into the Rugged Communications and Charging Cradle.

1. Open the access cover.

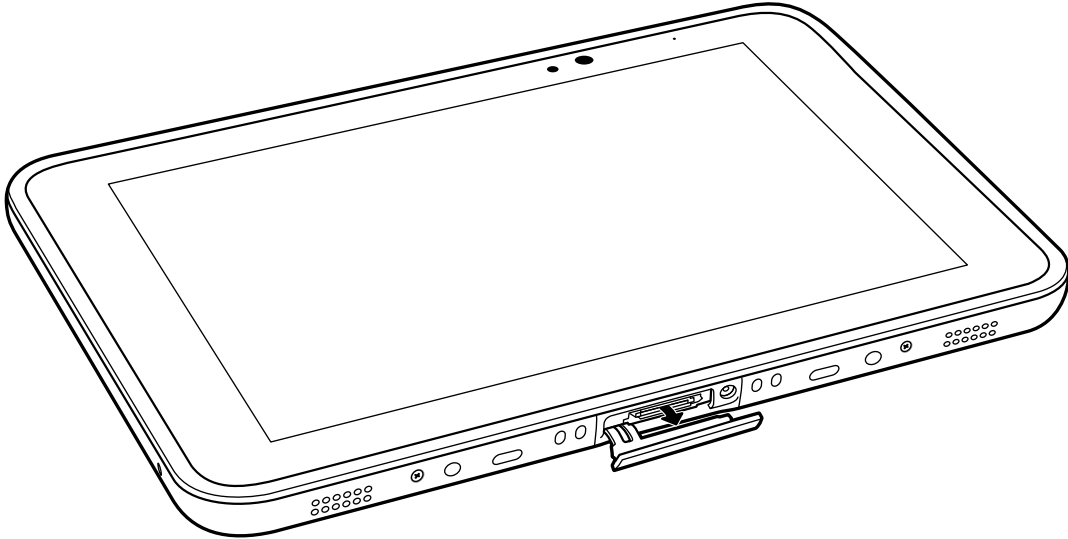

2. If installing the Rugged IO Adapter, pull the access cover away from the device until it separates from the device.

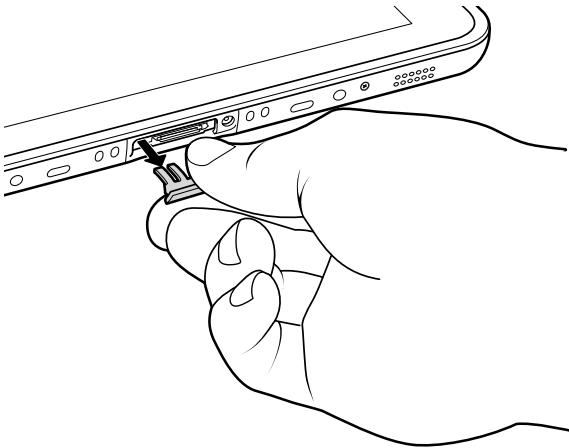



3. Insert the Rugged IO Adapter onto the tablet.

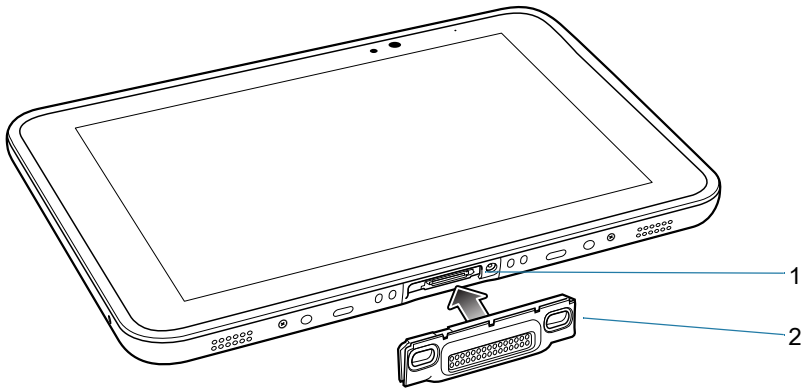

1	Interface connector
2	Rugged IO adapter

4. Remove the Rugged Frame and screws from box.
5. Separate the top and bottom sections of the Rugged Frame.
6. Place the bottom section on a flat surface.

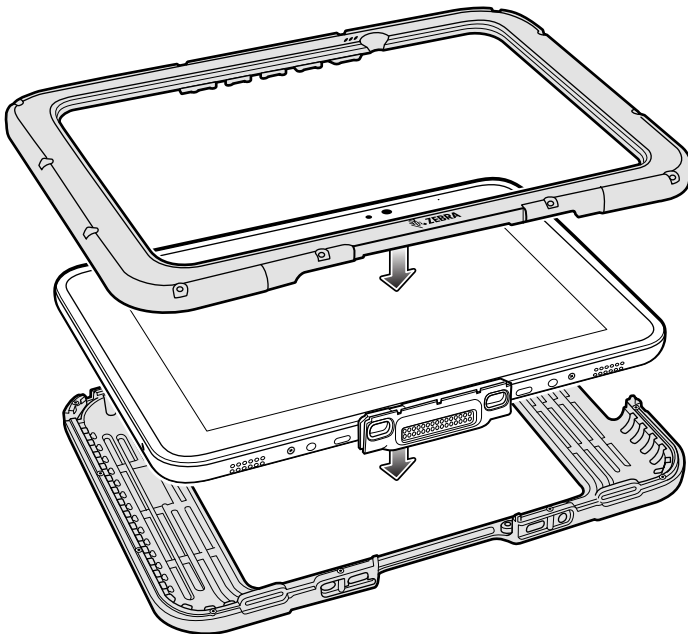

7. Place the device into the bottom section.
8. Align the top section over the bottom section.
9. Press the top section down onto the bottom section.
10. Using a T6 Torx screwdriver, secure the Rugged Frame together using the provided M1.6 Torx screws.

**Figure 42** Secure 8 in. Rugged Frame

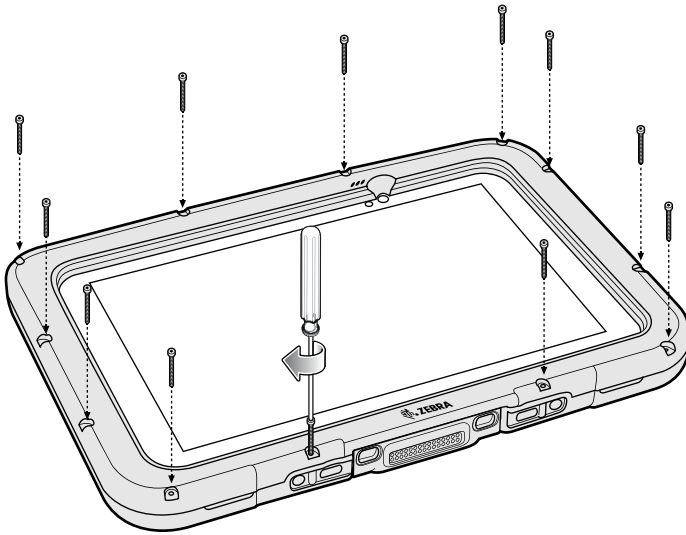

**Figure 43** Secure 10 in. Rugged Frame

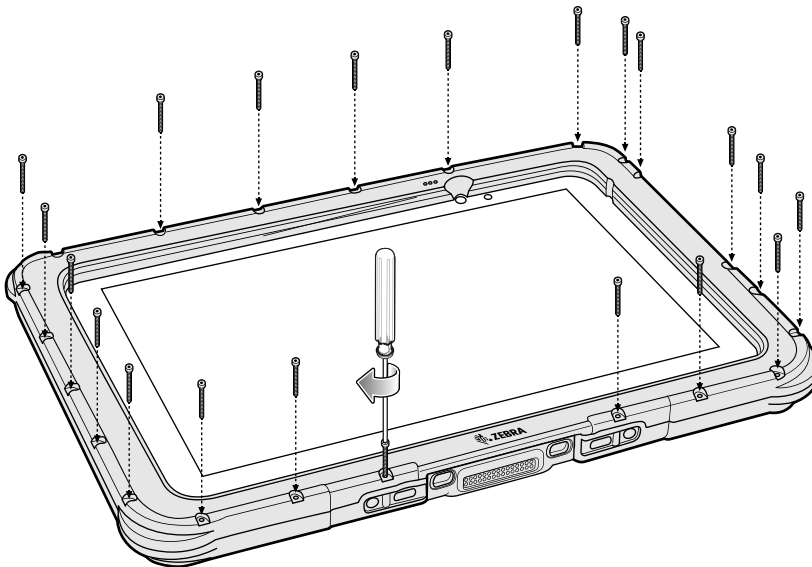

11. Torque the screws to 12 N-cm.

## Expansion Back

The Expansion Backs provide data capture and or Power Pack slot for the device.

### Installation

To install an Expansion Back:



**CAUTION:** Remove power before installing the Expansion Back.

1. Power off the device.
2. Remove battery cover and store in safe place.

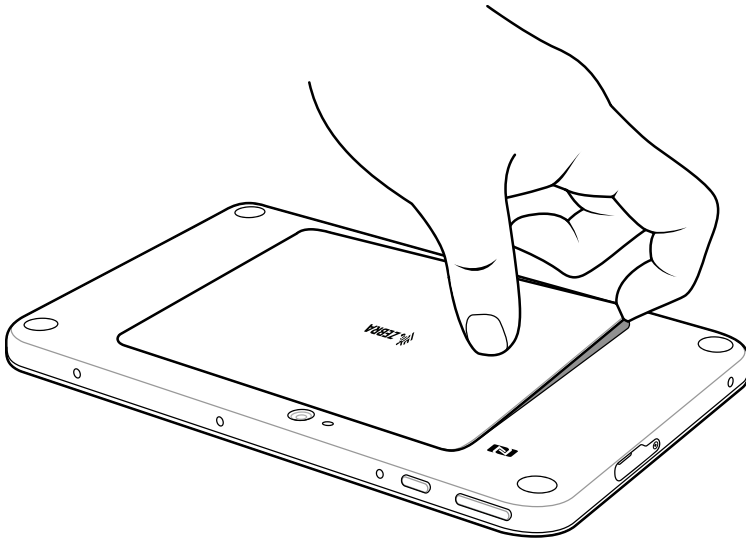

3. On 8.4 in. version only, remove rubber gasket.

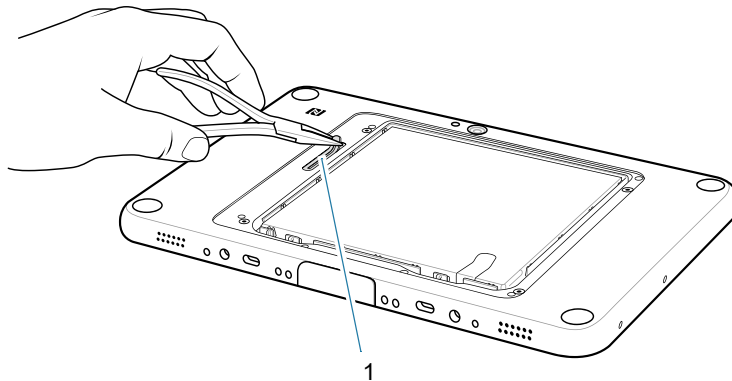

1	Rubber gasket
---	---------------

- Align expansion back with device. Ensure that the power pack slot cover is aligned with the bottom of the device and the interface connector on expansion back aligns with interface connector on device.

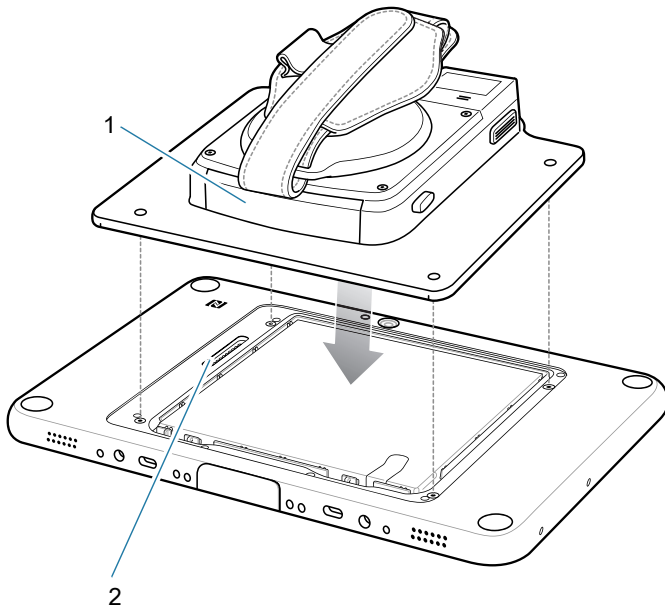

1	Power pack slot cover
2	Interface connector

**Figure 44** Align Expansion Back with 8 in. Configuration

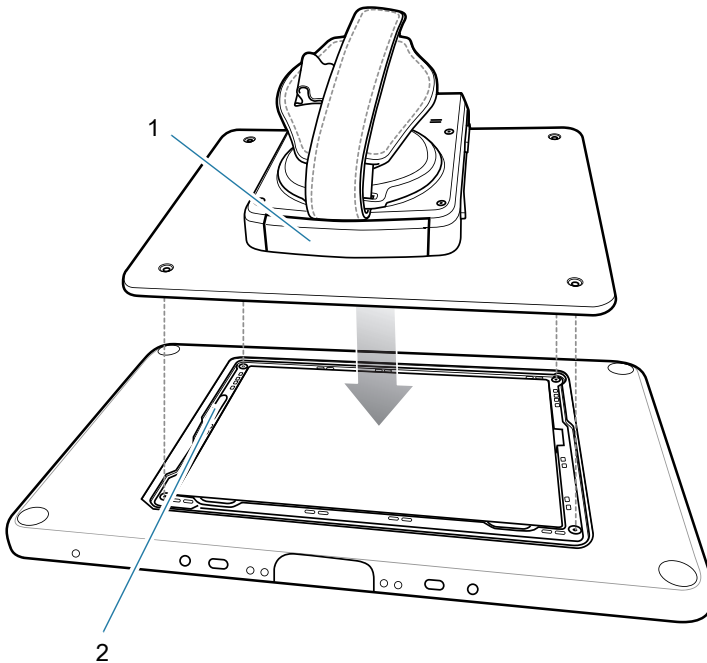

1	Power pack slot cover
2	Interface connector

- Using a T6 Torx screwdriver, secure expansion back to device using four screws. Torque to 14 n-cm.

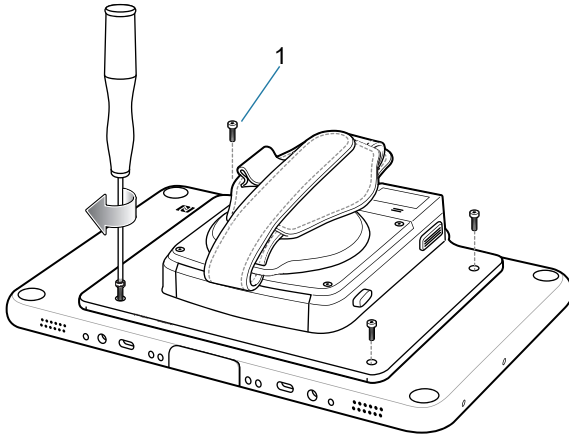

1	Screws (4)
---	------------

## Replacement Hand Strap

To replace the hand strap:

- If the Power Pack is installed, remove the Power Pack.
- Rotate the disk so that the strap end without the eyelet is aligned with the Power Pack opening.
- Open both ends of the hand strap.

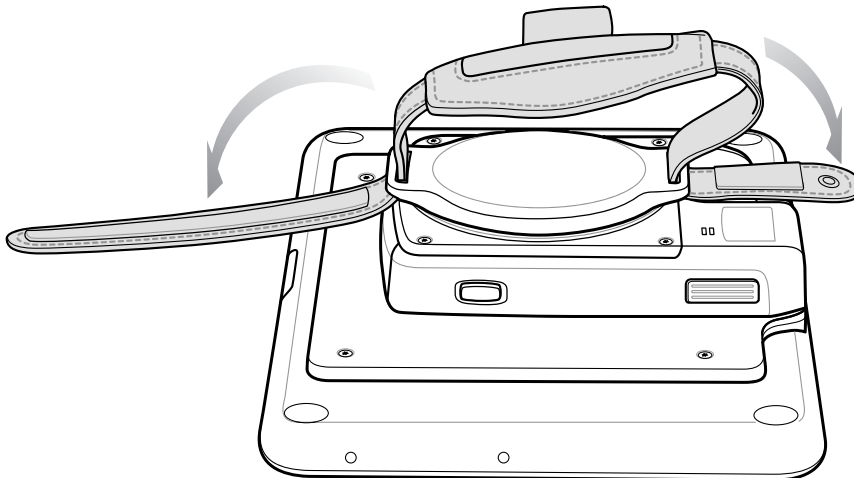

4. Pull the strap end without the eyelet through the slot on the Expansion Back.

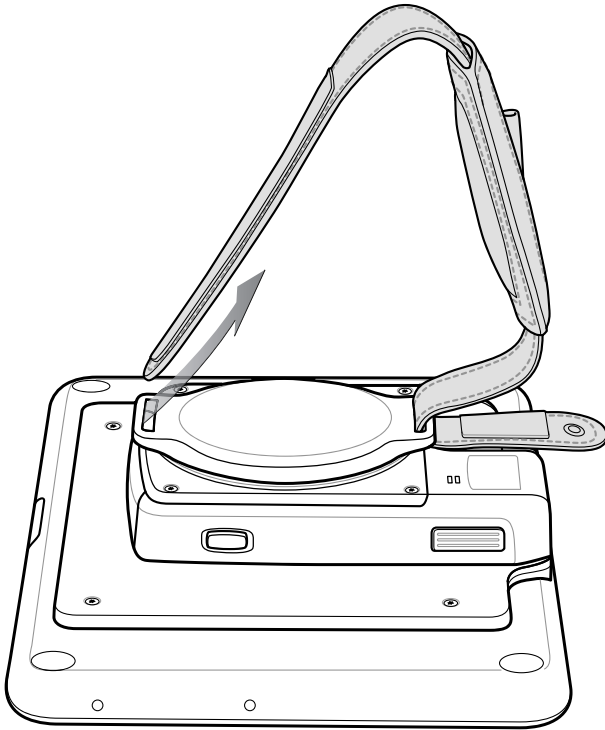

5. Rotate the disk 180°.
6. Slide the pad off the hand strap.
7. Pull the eyelet end through the slot on the Expansion Back.

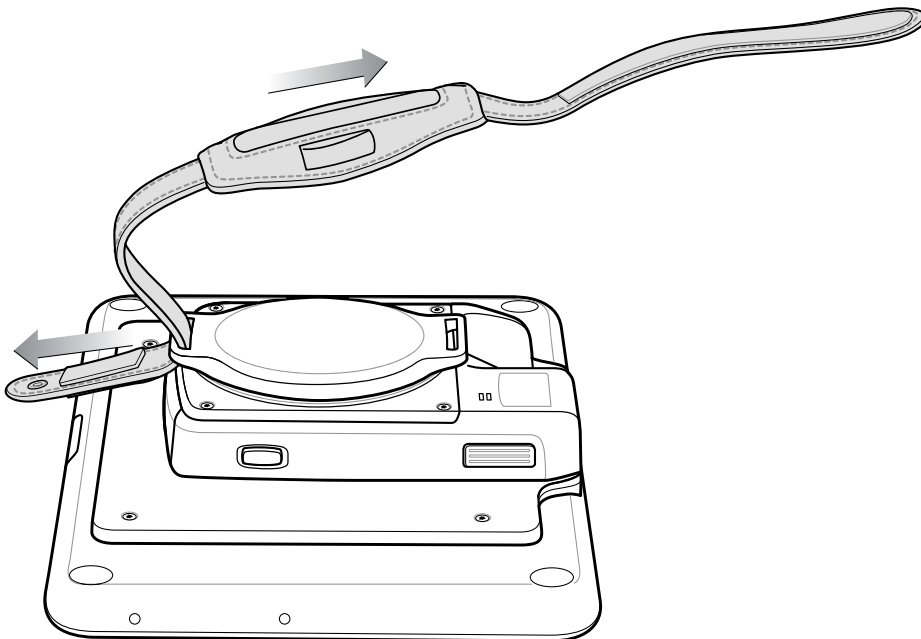

8. Remove pad from new replacement hand strap.
9. Rotate the disk so that one of the slots is aligned with the Power Pack opening.

10. Feed the new hand strap through the slot at the Power Pack opening.

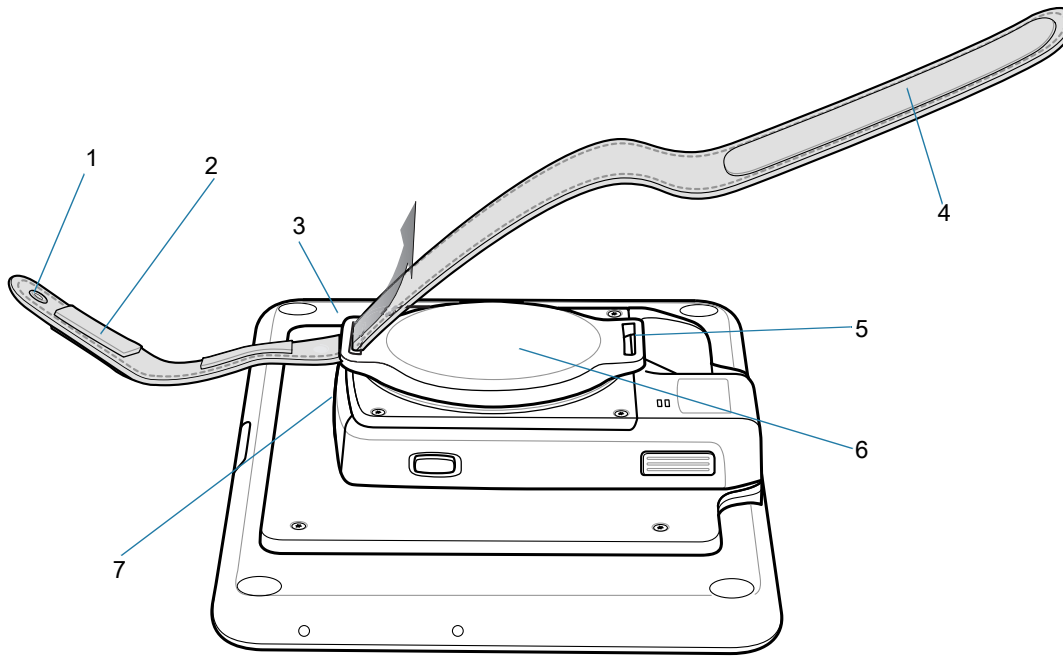

1	Eyelet
2	Hook material
3	Disk slot
4	Hook material
5	Disk slot
6	Hand strap disk
7	Power pack opening

11. Slide pad onto hand strap with the stylus holder facing up.

12. Fold the eyelet end of the strap up and press hook and loop material together.

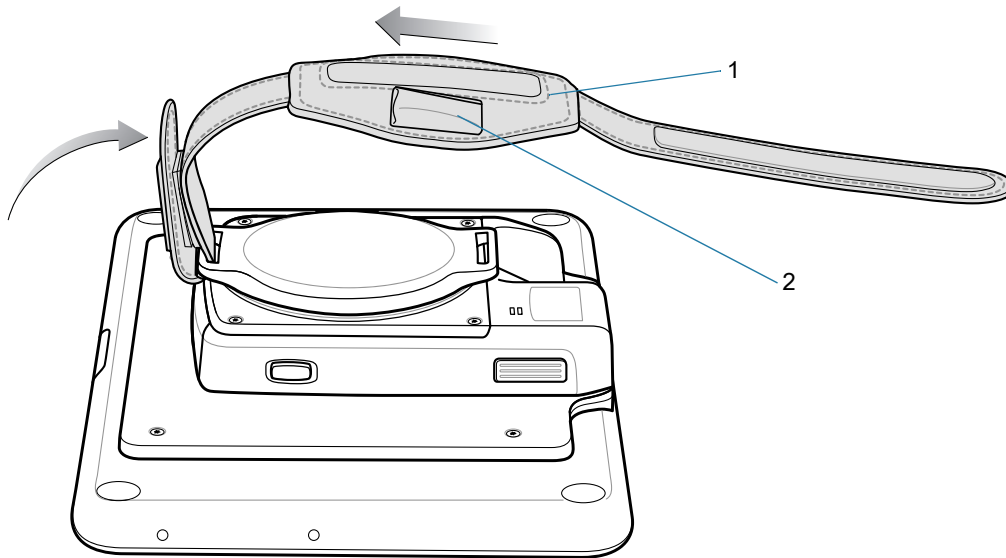

1	Pad
2	Stylus holder

13. Rotate disk 180° so that the empty slot is aligned with the Power Pack opening.

14. Feed strap through the slot.

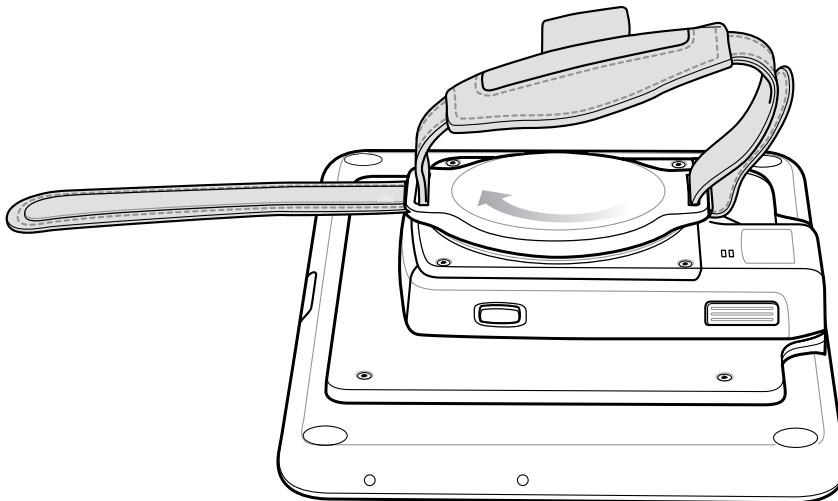



15. Fold the end of the strap up and press hook and loop material together.

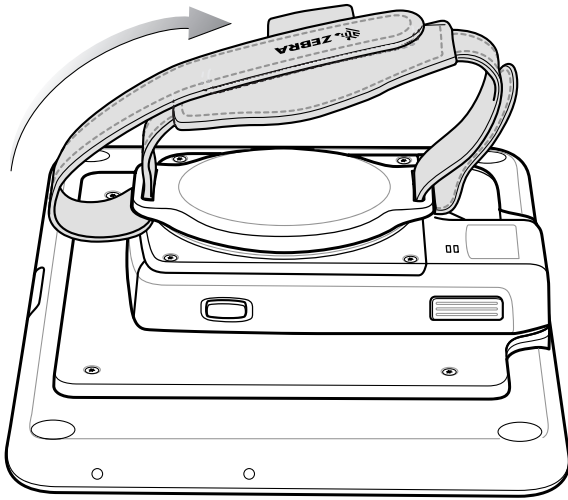

## Attaching the Stylus to the Expansion Back

The Expansion Backs provide a holder for the stylus. To install the stylus onto the Expansion Back with the option tether:

1. Insert one loop of the tether into the hole in the stylus end cap.

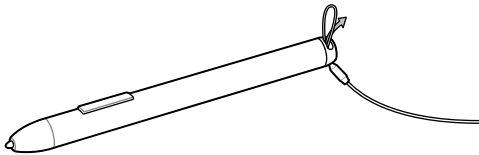

2. Feed the other end of the tether through the loop.

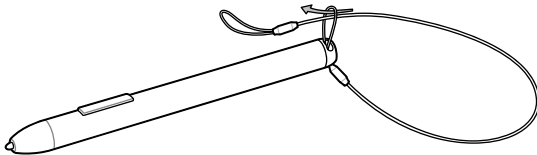

3. Pull the tether all the way through the loop.
4. Insert the loop of the tether through the eyelet on the hand strap of the Expansion Back.
5. Feed the stylus through the loop.

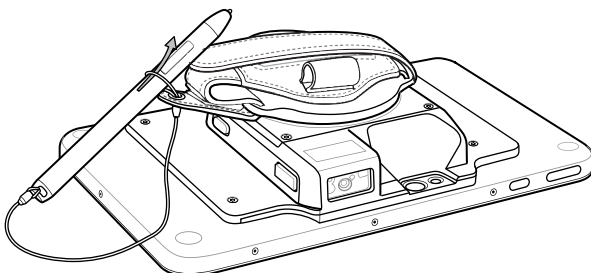

6. Pull the stylus all the way through the loop.

7. Slide the stylus into the holder for storing the stylus.

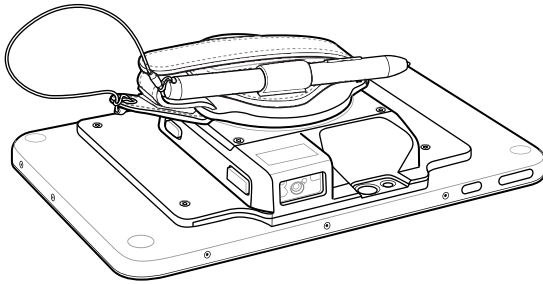

## Removal

To remove an Expansion Back:



**CAUTION:** Remove power before removing the Expansion Back.

1. Power off the device.
2. Using a T6 Torx screwdriver, remove four screws securing expansion back to device.

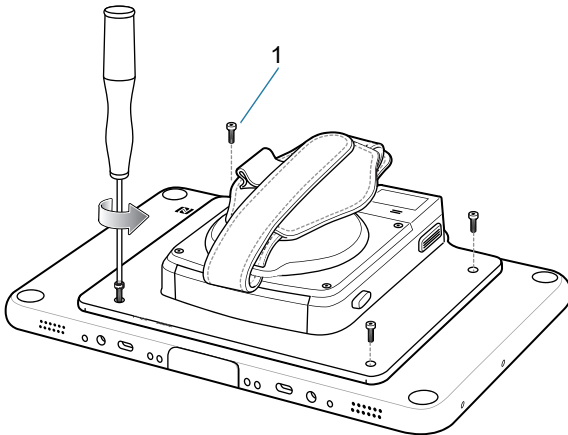

1	Screws (4)
---	------------

3. Lift Expansion Back off device.

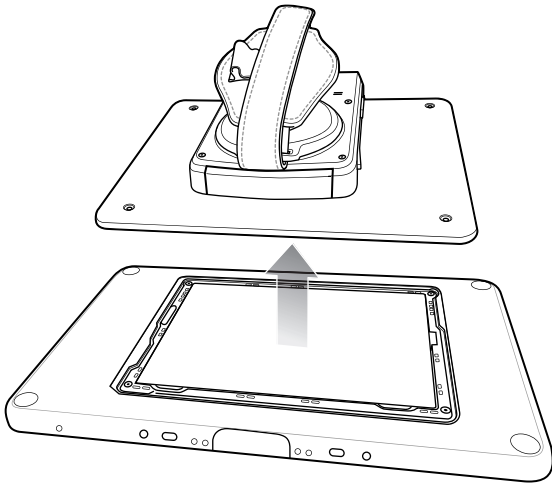

4. On 8 in. version only, replace rubber gasket removed during installation.

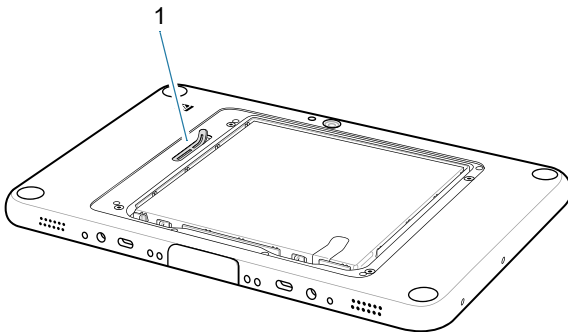

1	Rubber gasket
---	---------------

5. Replace battery cover.

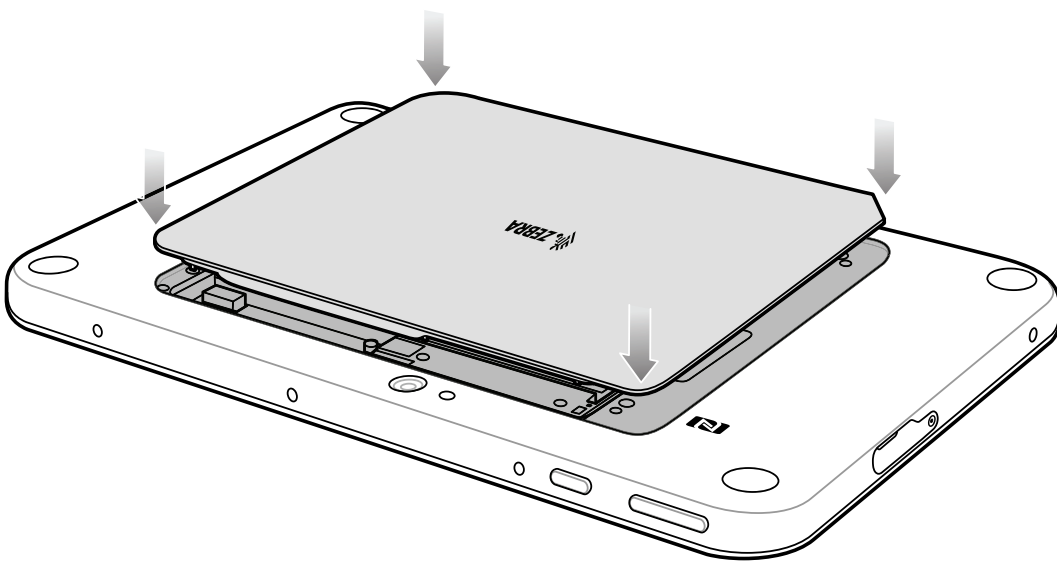

6. Carefully press down around the edge of the cover. Make sure that the cover is seated properly.

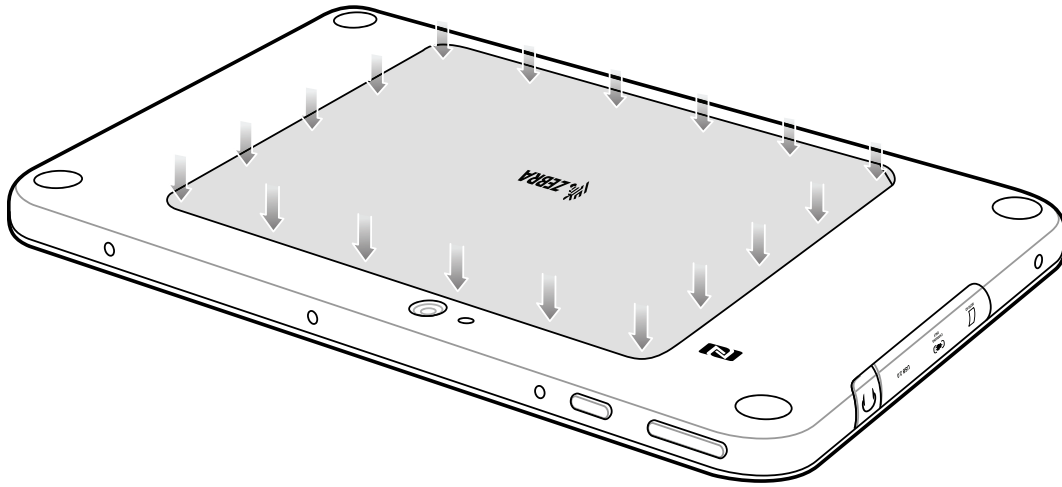

7. Press the Power button to turn on the device.

## ET51 with Integrated Scanner Hand Strap

The ET51 Enterprise Tablet with Integrated Scanner comes with additional screws for securing the hand strap to the device.

### Removing the Hand Strap

To remove the hand strap:

1. Push the hand strap stud through the hole of the lower hand strap.
2. Pull the lower hand strap from the upper hand strap.
3. Remove the two screws and two washers securing the upper and lower hand strap to the device.

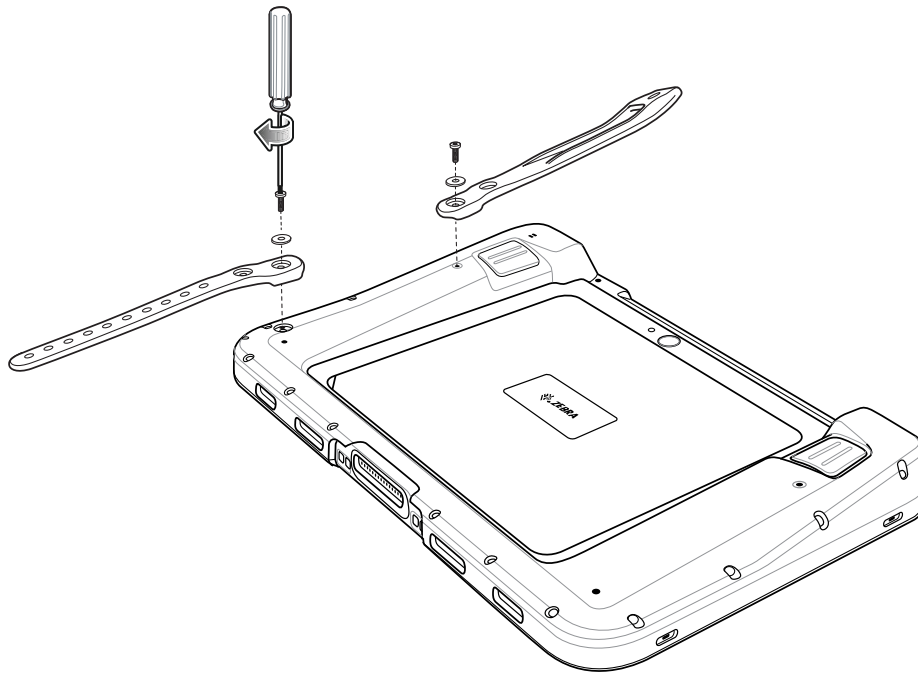

### Installing the Hand Strap on the Back of the Device

To install the hand strap on the back of the device:

1. Align the upper and lower hand strap mounting holes with the screw holes on the device.

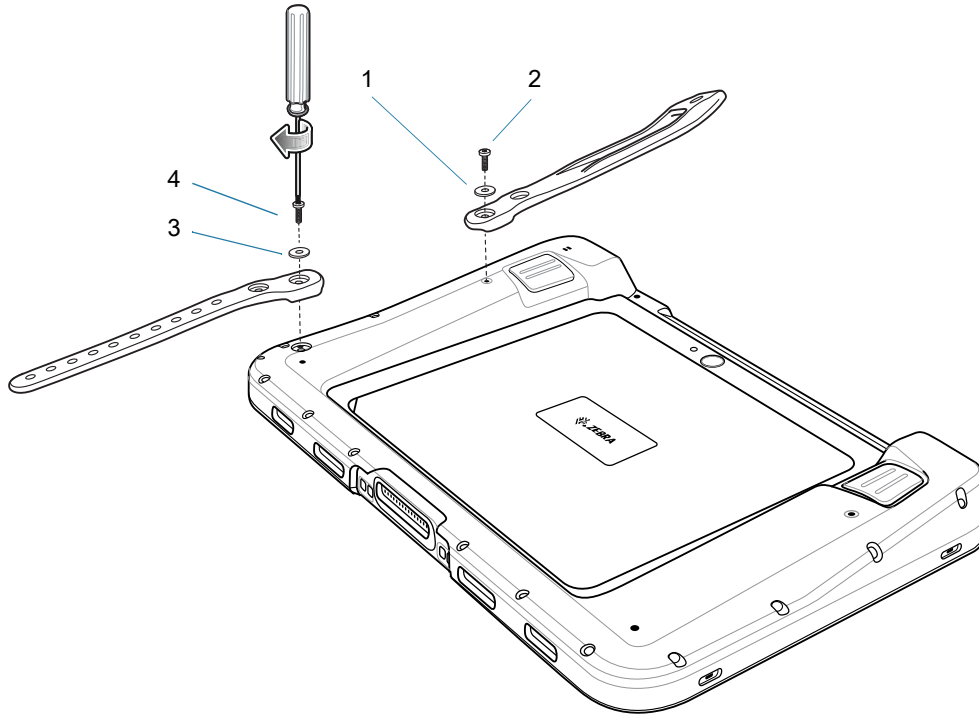

1	Washer
2	M2x6 Screw
3	Washer
4	M2.5x11 Screw

2. Using a T6 Torx screwdriver, secure the upper and lower hand strap to the device using the one M2x6 screw, one M2.5x11 screw, and two washers.
3. Torque the screws to 20 N-cm (1.77 lb in).
4. Feed the lower half of the hand strap through the upper half.

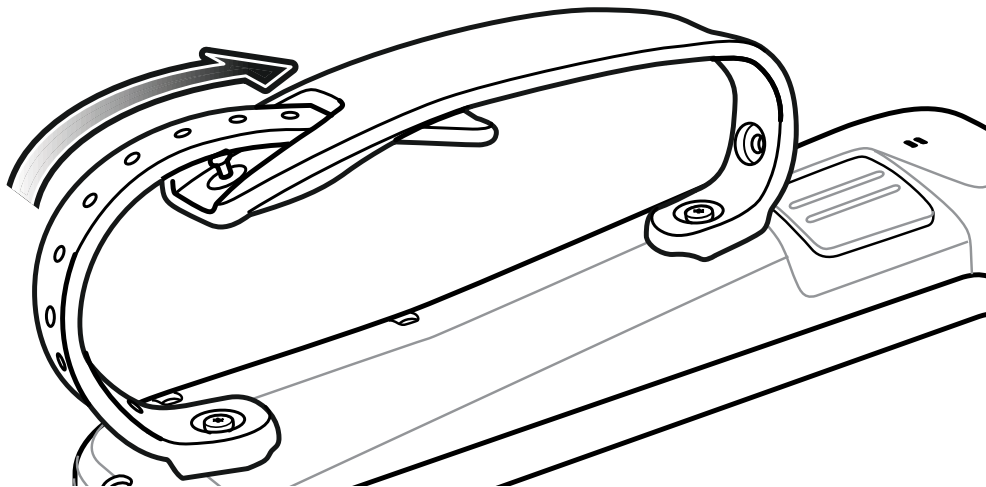

5. Position the hand strap for the right fit.
6. Align the stud with a hole in the lower half.

7. Press the lower hand strap down until the stud comes through the hole.

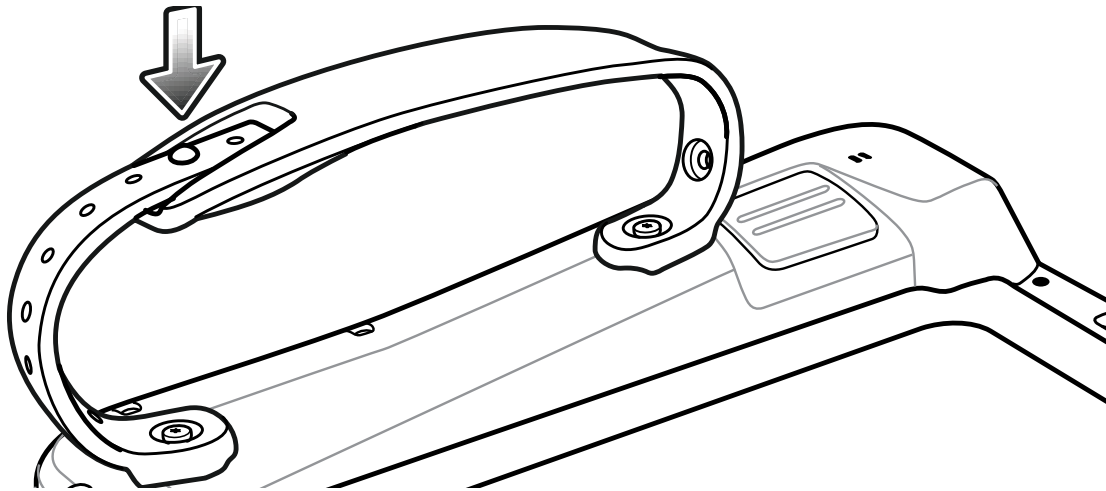

## Installing the Hand Strap on the Side of the Device

To install the hand strap on the side of the device:

1. Align the upper and lower hand strap mounting holes with the screw holes on the device.

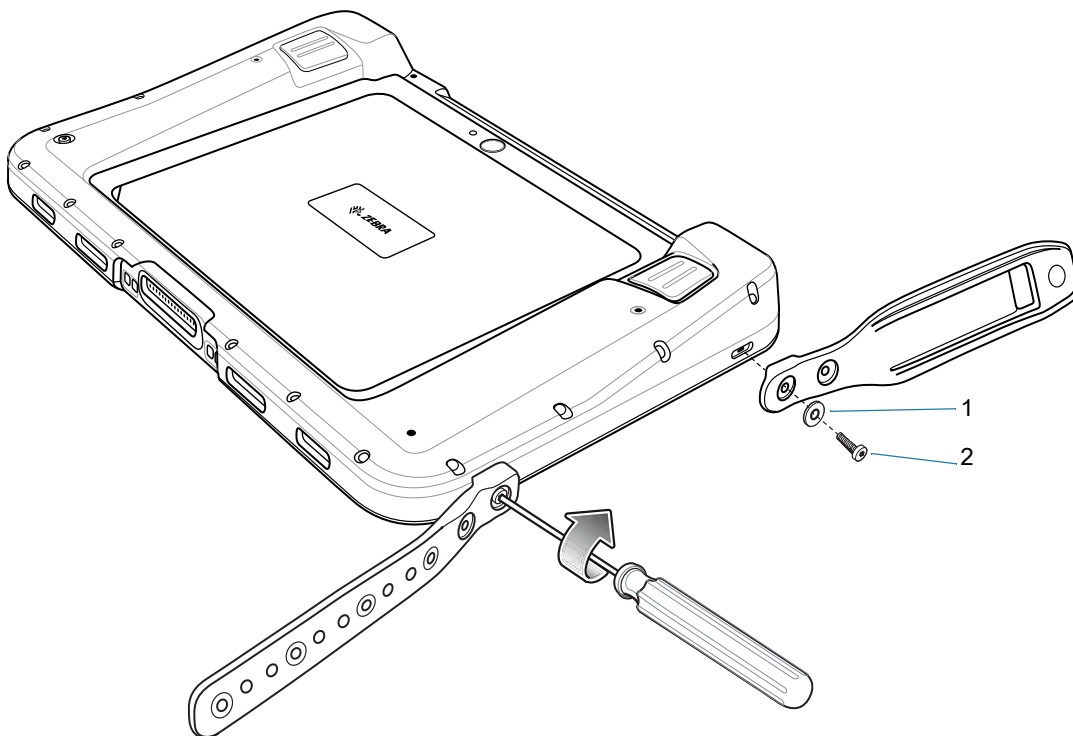

1	Washer
2	M2.5x11 screw

2. Using a T6 Torx screwdriver, secure the upper and lower hand strap to the device using the two M2.5x11 screws, and two washers.
3. Torque the screws to 20 N-cm (1.77 lb in).

4. Feed the lower half of the hand strap through the upper half.

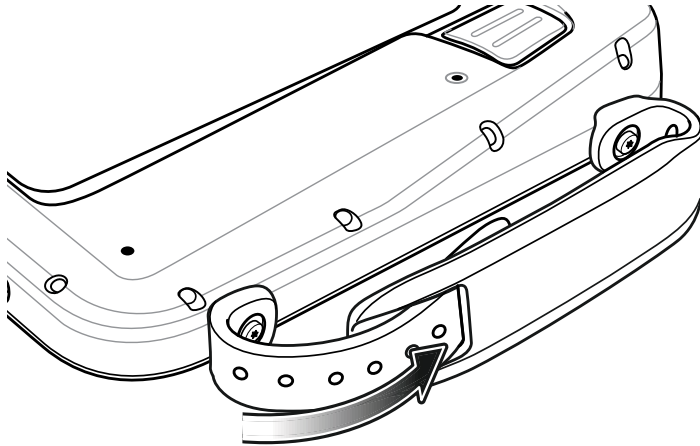

5. Position the hand strap for the right fit.
6. Align the stud with a hole in the lower half.
7. Press the lower hand strap down until the stud comes through the hole.

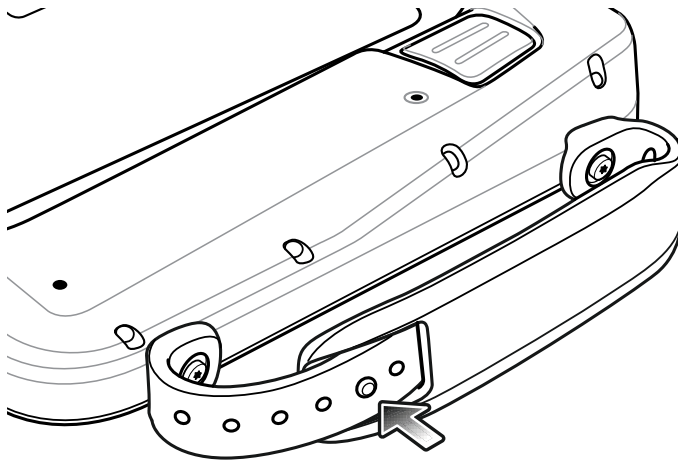



# Application Deployment

## Security

The device implements a set of security policies that determine whether an application is allowed to run and, if allowed, with what level of trust. To develop an application, you must know the security configuration of the device, and how to sign an application with the appropriate certificate to allow the application to run (and to run with the needed level of trust).



**NOTE:** Ensure the date is set correctly before installing certificates or when accessing secure web sites.

## Secure Certificates

If the VPN or Wi-Fi networks rely on secure certificates, obtain the certificates and store them in the device's secure credential storage, before configuring access to the VPN or Wi-Fi networks.

If downloading the certificates from a web site, set a password for the credential storage. The device supports X.509 certificates saved in PKCS#12 key store files with a .p12 extension (if key store has a .pfx or other extension, change to .p12).

The device also installs any accompanying private key or certificate authority certificates contained in the key store.

## Installing a Secure Certificate

To install a secure certificate:

1. Copy the certificate from the host computer to the root of the microSD card or the device's internal memory. See [USB Communication on page 36](#) for information about connecting the device to a host computer and copying files.
2. Go to **Settings**.
3. Touch **Security > Advanced > Encryption & credentials**.
4. Touch **Install from storage**.
5. Navigate to the location of the certificate file.
6. Touch the filename of the certificate to install.
7. If prompted, enter the password for credential storage. If a password has not been set for the credential storage, enter a password for it twice and then touch **OK**.
8. If prompted, enter the certificate's password and touch **OK**.

9. Enter a name for the certificate and in the Credential use drop-down, select **VPN and apps** or **Wi-Fi**.
10. Touch **OK**.

The certificate can now be used when connecting to a secure network. For security, the certificate is deleted from the microSD card or internal memory.

### Configuring Credential Storage Settings

1. Go to **Settings**.
2. Touch **Security > Advanced > Encryption & credentials**.
  - **Trusted credentials** - Touch to display the trusted system and user credentials.
  - **User credentials** - Touch to display user credentials.
  - **Install from storage** - Touch to install a secure certificate from the internal storage.
  - **Clear credentials** - Deletes all secure certificates and related credentials.

## Development Tools

Development tools for Android include Android Studio, EMDK for Android, and StageNow.

### Android Application Development

#### Development Workstation

Android development tools are available at [developer.android.com](http://developer.android.com).

To start developing applications for the device, download Android Studio. Development can take place on a Microsoft® Windows®, Mac® OS X®, or Linux® operating system.

Applications are written in Java or Kotlin, but compiled and executed in the Dalvik virtual machine. Once the Java code is compiled cleanly, the developer tools make sure the application is packaged properly, including the AndroidManifest.xml file.

Android Studio contains a full featured IDE as well as SDK components required to develop Android applications.

#### Enabling Developer Options

The **Developer options** screen sets development related settings. By default, the Developer Options are hidden.

1. Go to **Settings**.
2. Touch **About phone**.
3. Scroll down to **Build number**.
4. Tap **Build number** seven times. The message **You are now a developer!** appears.
5. Touch the Back button.
6. Touch **System > Advanced > Developer options**.
7. Slide the **USB debugging** switch to the **ON** position.

### EMDK for Android

EMDK for Android provides developers with tools to create business applications for enterprise mobile devices. It is designed for use with Google's Android Studio and includes Android class libraries such as Barcode, sample applications with source code, and the associated documentation.

EMDK for Android allows applications to take full advantage of the capabilities that Zebra devices have to offer. It embeds Profile Manager technology within Android Studio IDE, providing a GUI-based development tool designed specifically for Zebra devices. This allows fewer lines of code, resulting in reduced development time, effort, and errors.

For more information go to: [techdocs.zebra.com](http://techdocs.zebra.com).

### StageNow

StageNow is Zebra's next-generation Android Staging Solution built on the MX platform. It allows quick and easy creation of device profiles, and can deploy to devices simply by scanning a barcode, reading a tag, or playing an audio file.

The StageNow Staging Solution includes the following components:

- The StageNow Workstation tool installs on the staging workstation (host computer) and lets the administrator easily create staging profiles for configuring device components, and perform other staging actions such as checking the condition of a target device to determine suitability for software upgrades or other activities. The StageNow Workstation stores profiles and other created content for later use.
- The StageNow Client resides on the device and provides a user interface for the staging operator to initiate staging. The operator uses one or more of the desired staging methods (print and scan a barcode, read an NFC tag or play an audio file) to deliver staging material to the device.

For more information go to: [techdocs.zebra.com](http://techdocs.zebra.com).

### GMS Restricted

GMS Restricted mode deactivates Google Mobile Services (GMS). All GMS apps are disabled on the device and communication with Google (analytics data collection and location services) is disabled.

Use StageNow to disable or enable GMS Restricted mode. After a device is in GMS Restricted mode, enable and disable individual GMS apps and services using StageNow. To ensure GMS Restricted mode persists after an Enterprise Reset, use the Persist Manager option in StageNow. For more information on StageNow, refer to [techdocs.zebra.com](http://techdocs.zebra.com).

### ADB USB Setup

To use the ADB, install the USB driver. This assumes that the development SDK has been installed on the host computer. Go to [developer.android.com/sdk/index.html](http://developer.android.com/sdk/index.html) for details on setting up the development SDK.

ADB driver for Windows and Linux are available on the Zebra Support Central web site at [zebra.com/support](http://zebra.com/support). Download the ADB and USB Driver Setup package. Follow the instructions with the package to install the ADB and USB drivers for Windows and Linux.

### Enabling USB Debugging

By default, USB debugging is disabled.

1. Go to **Settings**.
2. Touch **About phone**.
3. Scroll down to **Build number**.
4. Tap **Build number** seven times. The message **You are now a developer!** appears.
5. Touch the Back button.
6. Touch **System > Advanced > Developer options**.
7. Slide the **USB debugging** switch to the **ON** position.
8. Touch **OK**.
9. Connect the device to the host computer using the Rugged Charge/USB Cable.  
The **Allow USB debugging?** dialog box appears on the device.
10. On the device, touch **OK**.
11. On the host computer, navigate to the **platform-tools** folder.
12. Type **adb devices**.  
The following displays:  
**List of devices attached**  
XXXXXXXXXXXXXXXXX device (where XXXXXXXXXXXXXXXXXXXX is the device number).



**NOTE:** If device number does not appear, ensure that ADB drivers are installed properly.

13. Touch the Home button.

## Entering Android Recovery Manually

Many of the update methods discussed in this section require putting the device into Android Recovery mode. If you are unable to enter Android Recovery mode through adb commands, use the following steps to manually enter Android Recovery mode.

1. Press and hold the Power button until the menu appears.
2. Touch **Restart**.
3. Press and hold the volume up button until the device vibrates. The System Recovery screen appears.

## Application Installation

After an application is developed, install the application onto the device using one of the following methods:

- USB connection, see [Installing Applications Using the USB Connection on page 103](#).
- Android Debug Bridge, see [Installing Applications Using the Android Debug Bridge on page 103](#).
- microSD Card, see [Installing Applications Using a microSD Card on page 104](#).
- Mobile device management (MDM) platforms that have application provisioning. Refer to the MDM software documentation for details.

## Installing Applications Using the USB Connection



**CAUTION:** When connecting the device to a host computer and mounting the microSD card, follow the host computer's instructions for connecting and disconnecting USB devices, to avoid damaging or corrupting files.



**NOTE:** Not supported on the ET51 Enterprise Tablet with Integrated Scanner.

1. Connect the device to a host computer using the USB-C cable.
2. Pull down the Notification panel and touch **Charging this device via USB**.
3. Touch **File Transfer**.
4. On the host computer, open a file manager application.
5. On the host computer, copy the application .apk file from the host computer to the device.



**CAUTION:** Carefully follow the host computer's instructions to unmount the microSD card and disconnect USB devices correctly to avoid losing information.

6. Disconnect the device from the host computer.
7. Swipe the screen up and select  to view files on the microSD card or Internal Storage.
8. Locate the application .apk file.
9. Touch the application file.
10. Touch **Continue** to install the app or **Cancel** to stop the installation.
11. To confirm installation and accept what the application affects, touch **Install** otherwise touch **Cancel**.
12. Touch **Open** to open the application or **Done** to exit the installation process. The application appears in the App list.

## Installing Applications Using the Android Debug Bridge

Use ADB commands to install application onto the device.



**CAUTION:** When connecting the device to a host computer and mounting its microSD card, follow the host computer's instructions for connecting and disconnecting USB devices, to avoid damaging or corrupting files.



**NOTE:** Not supported on the ET51 Enterprise Tablet with Integrated Scanner.



1. Ensure that the ADB drivers are installed on the host computer. See [ADB USB Setup on page 101](#).
2. Connect the device to a host computer using USB. See [USB Communication on page 36](#).
3. Go to **Settings**.
4. Touch **System > Advanced > Developer options**.
5. Slide the switch to the **ON** position.
6. Touch **USB Debugging**. A check appears in the check box. The **Allow USB debugging?** dialog box appears.
7. Touch **OK**.

8. On the host computer, open a command prompt window and use the adb command:  
`adb install <application>`  
where: <application> = the path and filename of the apk file.
9. Disconnect the device from the host computer. See [USB Communication on page 36](#).

### Installing Applications Using a microSD Card



**CAUTION:** When connecting the device to a host computer and mounting its microSD card, follow the host computer's instructions for connecting and disconnecting USB devices, to avoid damaging or corrupting files.

1. Copy the apk file to the root of the microSD card.
  - Copy the apk file to a microSD card using a host computer (see [USB Communication](#) for more information), and then installing the microSD card into the device (see [Replacing the microSD Card](#) for more information).
  - Connect the device with a microSD card already installed to the host computer, and copy apk file to the microSD card. See [USB Communication](#) for more information. Disconnect the device from the host computer.
2. Copy the application APK file from the host computer to the microSD card.
3. Remove the microSD card from the host computer.
4. Press and hold the Power button on the device until the menu appears.
5. Touch **Power off**.
6. Insert the microSD card.
7. Replace the battery.
8. Replace the battery cover.
9. Press and hold the Power button to turn on the device.
10. Swipe the screen up and select  to view files on the microSD card.
11. Touch  > **SD card**.
12. Locate the application .apk file.
13. Touch the application file.
14. Touch **Continue** to install the app or **Cancel** to stop the installation.
15. To confirm installation and accept what the application affects, touch **Install** otherwise touch **Cancel**.
16. Touch **Open** to open the application or **Done** to exit the installation process. The application appears in the App list.

### Uninstalling an Application

1. Go to **Settings**.
2. Touch **Apps & notifications**.
3. Touch **See all apps** to view all apps in the list.
4. Scroll through the list to the app.
5. Touch the app. The **App info** screen appears.

6. Touch **Uninstall**.
7. Touch **OK** to confirm.

## Performing a System Update



**CAUTION:** These update procedures are only for updating an Android tablet (ET51CE, ET51CT, ET56DE, ET56DT). Do not attempt to update a Windows Tablet (ET51AE, ET56BE, ET51AT, ET56BT) with Android software.

System Update packages can contain either partial or complete updates for the operating system. Zebra distributes the System Update packages on the Zebra Support & Downloads web site. Perform a system update using ADB.

### Downloading the System Update Package

1. Go to the Zebra Support & Downloads web site, [zebra.com/support](http://zebra.com/support).
2. Download the appropriate System Update package to a host computer.

### Performing a System Update Using microSD Card

It is strongly recommended that prior to use, you must format the microSD card on the device.

1. Copy the System Update zip file to the root of the microSD card.
  - Copy the zip file to a microSD card using a host computer (see USB Communication for more information), and then installing the microSD card into the device (see Replacing the microSD Card for more information).
  - Connect the device with a microSD card already installed to the host computer, and copy zip file to the microSD card. See USB Communication for more information. Disconnect the device from the host computer.
2. Press and hold the Power button until the menu appears.
3. Touch **Restart**.
4. Press and hold the volume up button until the device vibrates. The System Recovery screen appears.
5. Press the Volume Up and Volume Down buttons to navigate to **Apply upgrade from SD card**.
6. Press the Power button.
7. Press the Volume Up and Volume Down buttons to navigate to **Full OTA Package** or **Diff OTA Package**.
8. Press the Power button.
9. Press the Volume Up and Volume Down buttons to navigate to the System Update file.
10. Press the Power button. The System Update installs and then the device returns to the Recovery screen.
11. Press the Power button to reboot the device.

### Performing a System Update Using ADB



**NOTE:** Not supported on the ET51 Enterprise Tablet with Integrated Scanner.

1. Go to **Settings**.
2. Touch **System > Advanced > Developer options**.
3. Slide the switch to the **ON** position.
4. Touch **USB Debugging**. A check appears in the check box. The **Allow USB debugging?** dialog box appears.
5. Touch **OK**.
6. On the host computer, open a command prompt window and use the adb command:  
`adb devices`  
The following displays:  
**List of devices attached**  
XXXXXXXXXXXXXXXXX device (where XXXXXXXXXXXXXXXXXXXX is the device number).



**NOTE:** If device number does not appear, ensure that ADB drivers are installed properly.

7. Type:  
`adb reboot recovery`  
If you are not able to enter Android Recovery mode through the adb command, go to [Entering Android Recovery Manually on page 102](#).
8. Press Enter. The System Recovery screen appears on the device.
9. Press the Volume Up and Volume Down buttons to navigate to **Apply upgrade from ADB**.
10. Press the Power button.
11. Use the Volume Up and Volume Down buttons to navigate to **Full OTA Package** or **Diff OTA Package**.
12. Press the Power button.
13. On the host computer command prompt window type:  
`adb sideload <file>`  
where: <file> = the path and filename of the zip file.
14. Press Enter. The System Update installs (progress appears as percentage in the Command Prompt window) and then the System Recovery screen appears on the device.
15. Press the Power button to reboot the device.

## Verifying System Update Installation

1. Go to **Settings**.
2. Touch **About phone**.
3. Scroll down to **Build number**.
4. Ensure that the build number matches the new system update package file number.

## Enterprise Reset

An Enterprise Reset erases all user data in the `/data` partition, including data in the primary storage locations (`/sdcard` and emulated storage).



Before performing an Enterprise Reset, provision all necessary configuration files and restore after the reset.

Perform Enterprise Reset using device settings, or ADB.

### Performing an Enterprise Reset From Device Settings

1. Go to **Settings**.
2. Touch **System > Reset options > Erase all data (enterprise reset)**.
3. Touch **Erase all data** twice to confirm the Enterprise Reset.

### Downloading the Enterprise Reset Package

1. Go to the Zebra Support & Downloads web site, [zebra.com/support](https://zebra.com/support).
2. Download the Enterprise Reset file to a host computer.

### Performing an Enterprise Reset Using microSD Card

1. Copy the Enterprise Reset zip file to the root of the microSD card.
  - Copy the zip file to a microSD card using a host computer (see USB Communication for more information) and then installing the microSD card into the device (see Replacing the microSD Card for more information).
  - Connect the device with a microSD card already installed to the host computer and copy zip file to the microSD card. See USB Communication for more information. Disconnect the device from the host computer.
2. Press and hold the Power button until the menu appears.
3. Touch **Restart**.
4. Press and hold the volume up button until the device vibrates. The System Recovery screen appears.
5. Press the Volume Up and Volume Down buttons to navigate to **Apply upgrade from SD card**.
6. Press the Power button.
7. Press the Volume Up and Volume Down buttons to navigate to **Full OTA Package**.
8. Press the Power button.
9. Press the Volume Up and Volume Down buttons to navigate to the Enterprise Reset file.
10. Press the Power button. The Enterprise Reset occurs and then the device returns to the Recovery screen.
11. Press the Power button to reboot the device.

### Performing an Enterprise Reset Using ADB

1. Connect the device to a host computer using a micro USB-C cable.
2. Go to **Settings**.
3. Touch **System > Advanced > Developer options**.
4. Slide the switch to the **ON** position.
5. Touch **USB Debugging**. A check appears in the check box. The **Allow USB debugging?** dialog box appears.

6. Touch **OK**.
7. On the host computer, open a command prompt window and type:

```
adb devices.
```

The following displays:

```
List of devices attached
```

```
XXXXXXXXXXXXXXXX device (where XXXXXXXXXXXXXXXXXXXX is the device number).
```



**NOTE:** If device number does not appear, ensure that ADB drivers are installed properly.

8. Type:

```
adb reboot recovery
```

If you are not able to enter Android Recovery mode through the adb command, go to [Entering Android Recovery Manually on page 102](#).

9. Press Enter. The System Recovery screen appears on the device.
10. Press the Volume Up and Volume Down buttons to navigate to **Apply upgrade from ADB**.
11. Press the Power button.
12. Press the Volume Up and Volume Down buttons to navigate to **Full OTA Package**.
13. Press the Power button.
14. On the host computer command prompt window type:

```
adb sideload <file>
```

where: <file> = the path and filename of the zip file.
15. Press Enter. The Enterprise Reset package installs and then the System Recovery screen appears on the device.
16. Press the Power button to reboot the device.

## Performing a Factory Reset

A Factory Reset erases all data in the `/data` and `/enterprise` partitions in internal storage and clears all device settings. A Factory Reset returns the device to the last installed operating system image. To revert to a previous operating system version, re-install that operating system image. See [Performing a System Update](#) for more information.

### Downloading the Factory Reset Package

To download the Factory Reset package:

1. Go to the Zebra Support & Downloads web site, [zebra.com/support](http://zebra.com/support).
2. Download the appropriate Factory Reset file to a host computer.

### Performing a Factory Reset Using microSD Card

1. Copy the Factory Reset zip file to the root of the microSD card.

- Copy the zip file to a microSD card using a host computer (see USB Communication for more information) and then installing the microSD card into the device (see Replacing the microSD Card for more information).
  - Connect the device with a microSD card already installed to the host computer and copy zip file to the microSD card. See USB Communication for more information. Disconnect the device from the host computer.
2. Press and hold the Power button until the menu appears.
  3. Touch **Restart**.
  4. Press and hold the Volume Up button until the device vibrates. The System Recovery screen appears.
  5. Press the Volume Up and Volume Down buttons to navigate to **Apply upgrade from SD card**.
  6. Press the Power button.
  7. Use the Volume Up and Volume Down buttons to navigate to **Full OTA Package**.
  8. Press the Power button.
  9. Use the Volume Up and Volume Down buttons to navigate to the Factory Reset file.
  10. Press the Power button. The Factory Reset occurs and then the device returns to the Recovery screen.
  11. Press the Power button to reboot the device.

## Performing a Factory Reset Using ADB

To perform an Factory Reset using ADB:

1. Connect the device to a host computer using a USB-C cable.
2. Go to **Settings**.
3. Touch **System > Advanced > Developer options**.
4. Slide the switch to the **ON** position.
5. Touch **USB Debugging**. A check appears in the check box. The **Allow USB debugging?** dialog box appears.
6. Touch **OK**.
7. On the host computer, open a command prompt window and type:

```
adb devices.
```

The following displays:

```
List of devices attached
```

```
XXXXXXXXXXXXXXXXX device (where XXXXXXXXXXXXXXXXXXXX is the device number).
```



**NOTE:** If device number does not appear, ensure that ADB drivers are installed properly.

8. Type:

```
adb reboot recovery
```

If you are not able to enter Android Recovery mode through the adb command, go to [Entering Android Recovery Manually on page 102](#).

9. Press Enter. The System Recovery screen appears on the device.
10. Press the Volume Up and Volume Down buttons to navigate to **Apply upgrade from ADB**.

11. Press the Power button.
12. Press the Volume Up and Volume Down buttons to navigate to **Full OTA Package**.
13. Press the Power button.
14. On the host computer command prompt window type:  
`adb sideload <file>`  
where: <file> = the path and filename of the zip file.
15. Press Enter. The Factory Reset package installs and then the System Recovery screen appears on the device.
16. Press the Power button to reboot the device.

## Storage

The device contains the following types of file storage:

- Random Access Memory (RAM)
- Internal storage
- Enterprise folder.

### Random Access Memory

Executing programs use RAM to store data. Data stored in RAM is lost upon a reset. The operating system manages how applications use RAM. It only allows applications and component processes and services to use RAM when required. It may cache recently used processes in RAM, so they restart more quickly when opened again, but it will erase the cache if it needs the RAM for new activities.

The screen displays the amount of used and free RAM.

- **Performance** - Indicates memory performance.
- **Total memory** - Indicates the total amount of RAM available.
- **Average used (%)** - Indicates the average amount of memory (as a percentage) used during the period of time selected (default - 3 hours).
- **Free** - Indicates the total amount of unused RAM.
- **Memory used by apps** - Touch to view RAM usage by individual apps.

### Viewing Memory

1. Go to **Settings**.
2. Touch **System > Advanced > Developer options > Memory**.

### Internal Storage

The device has internal storage. The internal storage content can be viewed and files copied to and from when the device is connected to a host computer. Some applications are designed to be stored on the internal storage rather than in internal memory.

### Viewing Internal Storage

1. Go to **Settings**.

2. Touch **Storage**.

If the device has removable storage installed, touch **Internal shared storage** to display a the amount of internal storage used by apps, photos, videos, audio and other files.

## External Storage

The device can have a removable microSD card. The microSD card content can be viewed and files copied to and from when the device is connected to a host computer.

### Viewing External Storage

1. Go to **Settings**.
2. Touch **Storage**.

Portable storage displays the total amount of space on the installed microSD card and the amount used.

To unmount the microSD card, touch .

### Formatting a microSD Card

1. Touch **SD card**.
2. Touch  > **Storage settings**.
3. Touch **Format**.
4. Touch **ERASE & FORMAT**.
5. Touch **DONE**.

### Formatting a microSD Card as Internal Memory

You can format a microSD card as internal memory to increase the actual amount of the device's internal memory. Once formatted, the microSD card can only be read by this device.

1. Touch **SD card**.
2. Touch  > **Storage settings**.
3. Touch **Format as internal**.
4. Touch **ERASE & FORMAT**.
5. Touch **DONE**.

## Enterprise Folder

The Enterprise folder (within internal flash) is a super-persistent storage that is persistent after a reset and an Enterprise Reset. The Enterprise folder is erased during a Factory Reset. The Enterprise folder is used for deployment and device-unique data. The Enterprise folder is approximately 128 MB (formatted). Applications can persist data after an Enterprise Reset by saving data to the enterprise/user folder. The folder is ext4 formatted and is only accessible from a host computer using ADB or from an MDM.

## Managing Apps

Apps use two kinds of memory: storage memory and RAM. Apps use storage memory for themselves and any files, settings, and other data they use. They also use RAM when they are running.

1. Go to **Settings**.
2. Touch **Apps & notifications**.
3. Touch **See all XX apps** to view all apps on the device.
4. Touch **⋮ > Show system** to include system processes in the list.
5. Touch an app, process, or service in the list to open a screen with details about it and, depending on the item, to change its settings, permissions, notifications and to force stop or uninstall it.



### App Details

Apps have different kinds of information and controls.

- **Force stop** - Stop an app.
- **Disable** - Disable an app.
- **Uninstall** - Remove the app and all of its data and settings from the device. See [Uninstalling an Application on page 104](#) for information about uninstalling apps.
- **Notifications** - Set the app notification settings.
- **Permissions** - Lists the areas on the device that the app has access to.
- **Storage & cache** - Lists how much information is stored, and includes buttons for clearing it.
- **Mobile data & Wi-Fi** - Provides information about data consumed by an app.
- **Advanced**
  - **Screen time** - Displays the amount of time the app has displayed on the screen.
  - **Battery** - Lists the amount of computing power used by the app.
  - **Open by default** - If you have configured an app to launch certain file types by default, you can clear that setting here.
  - **Display over other apps** - allows an app to display on top of other apps.
  - **App details** - Provides a link to additional app details on the Play store.
  - **Additional settings in the app** - Opens settings in the app.
  - **Modify system settings** - Allows an app to modify the system settings.

### Managing Downloads

Files and apps downloaded using the Browser or Email are stored on the Internal storage in the Download directory. Use the Downloads app to view, open, or delete downloaded items.

1. Swipe the screen up and touch .
2. Touch **≡ > Downloads**.
3. Touch and hold an item, select items to delete and touch . The item is deleted from the device.

# Maintenance and Troubleshooting

## Introduction

This chapter includes instructions on cleaning and storing the tablet, battery maintenance and provides troubleshooting solutions for potential problems during tablet operations.

## Maintaining the Device

For trouble-free service, observe the following tips when using the device:

- To avoid scratching the screen, use a the supplied Zebra approved stylus or plastic-tipped pens capacitive touch panel compatible stylus intended for use with a touch-sensitive screen. Never use an actual pen or pencil or other sharp object on the surface of the device screen.
- The touch-sensitive screen of the device is glass. Do not drop the device or subject it to strong impact.
- Protect the device from temperature extremes. Do not leave it on the dashboard of a car on a hot day, and keep it away from heat sources.
- Do not store the device in any location that is dusty, damp, or wet.
- Use a soft lens cloth to clean the device. If the surface of the device screen becomes soiled, clean it with a soft cloth moistened with an approved cleanser. For a list of approved cleansers, see Approved Cleanser Active Ingredients.
- Periodically replace the rechargeable battery to ensure maximum battery life and product performance. Battery life depends on individual usage patterns.

## Battery Safety Guidelines

- The area in which the units are charged should be clear of debris and combustible materials or chemicals. Particular care should be taken where the device is charged in a non commercial environment.
- Follow battery usage, storage, and charging guidelines found in this guide.
- Improper battery use may result in a fire, explosion, or other hazard.
- To charge the mobile device battery, the ambient battery and charger temperatures must be between +32°F and +104°F (0°C and +40°C).
- Do not use incompatible batteries and chargers, including non-Zebra batteries and chargers. Use of an incompatible battery or charger may present a risk of fire, explosion, leakage, or other hazard. If you have any questions about the compatibility of a battery or a charger, contact the Global Customer Support Center.

- For devices that utilize a USB port as a charging source, the device shall only be connected to products that bear the USB-IF logo or have completed the USB-IF compliance program.
- Do not disassemble or open, crush, bend or deform, puncture, or shred the battery.
- Severe impact from dropping any battery-operated device on a hard surface could cause the battery to overheat.
- Do not short circuit a battery or allow metallic or conductive objects to contact the battery terminals.
- Do not modify or remanufacture, attempt to insert foreign objects into the battery, immerse or expose to water or other liquids, or expose to fire, explosion, or other hazard.
- Do not leave or store the equipment in or near areas that might get very hot, such as in a parked vehicle or near a radiator or other heat source. Do not place battery into a microwave oven or dryer.
- Battery usage by children should be supervised.
- Please follow local regulations to properly dispose of used re-chargeable batteries.
- Do not dispose of batteries in fire.
- In the event of a battery leak, do not allow the liquid to come in contact with the skin or eyes. If contact has been made, wash the affected area with water for 15 minutes, and seek medical advice.
- If you suspect damage to your equipment or battery, contact Customer Support to arrange for inspection.

## Cleaning Instructions



**CAUTION:** Always wear eye protection. Read warning label on alcohol product before using. If you have to use any other solution for medical reasons please contact the Global Customer Support Center for more information.



**WARNING:** Avoid exposing this product to contact with hot oil or other flammable liquids. If such exposure occurs, unplug the device and clean the product immediately in accordance with these guidelines.

## Approved Cleanser Active Ingredients

100% of the active ingredients in any cleaner must consist of one or some combination of the following: isopropyl alcohol, bleach/sodium hypochlorite<sup>1</sup> (see important note below), or mild dish soap.



**IMPORTANT:** Use pre-moistened wipes and do not allow liquid cleaner to pool.

<sup>1</sup>When using sodium hypochlorite (bleach) based products, always follow the manufacturer's recommended instructions: use gloves during application and remove the residue afterwards with a damp alcohol cloth or a cotton swab to avoid prolonged skin contact while handling the device.

Due to the powerful oxidizing nature of sodium hypochlorite, the metal surfaces on the device are prone to oxidation (corrosion) when exposed to this chemical in the liquid form (including wipes). In the event that these type of disinfectants come in contact with metal on the device, prompt removal with an alcohol-dampened cloth or cotton swab after the cleaning step is critical.



### Harmful Ingredients

The following chemicals are known to damage the plastics on the device and should not come in contact with the device: acetone; ketones; ethers; aromatic and chlorinated hydrocarbons; aqueous or alcoholic alkaline solutions; ethanolamine; toluene; trichloroethylene; benzene; carbolic acid and TB-lysoform.

Many vinyl gloves contain phthalate additives, which are often not recommended for medical use and are known to be harmful to the housing of the device.

### Device Cleaning Instructions

Do not apply liquid directly to the device. Dampen a soft cloth or use pre-moistened wipes. Do not wrap the device in the cloth or wipe, instead gently wipe the unit. Be careful not to let liquid pool around the display window or other places. Before use, allow the unit to air dry.



**NOTE:** For thorough cleaning, it is recommended to first remove all accessory attachments, such as hand straps or cradle cups, from the mobile device and to clean them separately.

### Special Cleaning Notes

The device should not be handled while wearing vinyl gloves containing phthalates, or before hands are washed to remove contaminant residue after gloves are removed.

If products containing any of the harmful ingredients listed above are used prior to handling the device, such as hand sanitizer that contain ethanolamine, hands must be completely dry before handling the device to prevent damage to the device.



**IMPORTANT:** If the battery connectors are exposed to cleaning agents, thoroughly wipe off as much of the chemical as possible and clean with an alcohol wipe. It is also recommended to install the battery in the terminal prior to cleaning and disinfecting the device to help minimize buildup on the connectors.

When using cleaning/disinfectant agents on the device, it is important to follow the directions prescribed by the cleaning/disinfectant agent manufacturer.

### Cleaning Materials Required

- Alcohol wipes
- Lens tissue
- Cotton-tipped applicators
- Isopropyl alcohol
- Can of compressed air with a tube.

### Cleaning Frequency

The cleaning frequency is at the customer's discretion due to the varied environments in which the mobile devices are used and may be cleaned as frequently as required. When dirt is visible, it is recommended to clean the mobile device to avoid build up of particles which make the device more difficult to clean later on.

For consistency and optimum image capture, it is recommended to clean the camera window periodically especially when used in environments prone to dirt or dust.

## Cleaning Battery Connectors

To clean the battery connectors:

1. Remove the main battery from the mobile computer.
2. Dip the cotton portion of the cotton-tipped applicator in isopropyl alcohol.
3. To remove any grease or dirt, rub the cotton portion of the cotton-tipped applicator back-and-forth across the connectors on the battery and terminal sides. Do not leave any cotton residue on the connectors.
4. Repeat at least three times.
5. Use a dry cotton-tipped applicator and repeat steps 3 and 4. Do not leave any cotton residue on the connectors.
6. Inspect the area for any grease or dirt and repeat the cleaning process if necessary.



**CAUTION:** After cleaning the battery connectors with bleach-based chemicals, follow the Battery Connector Cleaning instructions to remove bleach from the connectors.

## Troubleshooting

### Resetting the Device

There are two reset function, soft reset and hard reset.

#### Performing a Soft Reset

Perform a soft reset if the applications stop responding.

1. Press and hold the Power button until the menu appears.
2. Touch Restart.

The device reboots.

#### Performing a Hard Reset



**CAUTION:** Performing a hard reset with a microSD card installed in the device may cause damage or data corruption to the microSD card.

Perform a hard reset if the device stops responding.

1. Press and hold the Power button and the Volume Up button.
2. When the screen turns off, release the buttons.

The device reboots.

**Table 9** Troubleshooting the Tablet

Problem	Cause	Solution
Tablet does not turn on.	Battery not charged.	Charge the battery in the tablet.
	Battery not installed properly.	Ensure battery is installed properly.
	System crash.	If the tablet does not turn on, perform a hard reset. See <a href="#">Performing a Hard Reset on page 117</a> .
Battery did not charge.	Battery failed.	Replace battery. If the tablet still does not operate, try a hard reset. See <a href="#">Performing a Hard Reset on page 117</a> .
	Tablet removed from cradle before charging completed.	Insert the tablet into the cradle and begin charging. The battery fully charges in approximately four hours.
	Ambient temperature of the cradle is too warm or too cold.	The ambient temperature must be between 0°C and 40°C (32 °F and 104°F).
Unable to connect to the wireless network.	SIM card is valid.	Ensure that the micro SIM card is valid and workable if using a mobile network.
	Not within range of network.	Move within the network's service range and the signal strength is good.
	device is in airplane mode.	Ensure that device is not in Airplane mode.

**Table 9** Troubleshooting the Tablet (Continued)

Problem	Cause	Solution
The multi-touch screen responds slowly or improperly.	Finger or screen is wet.	Ensure that your hands are clean and dry when touching the screen. Restart the tablet to try again.
Tablet turns itself off.	Tablet is inactive.	The tablet turns off after a period of inactivity. If the tablet is running on battery power.
	Battery is depleted.	Place the tablet in the cradle to re-charge the battery.
	The tablet's battery is low and it powers down to protect memory content.	Place the tablet in a cradle to re-charge the battery.

## Charge Only Cradle

**Table 10** Troubleshooting the Charge only Cradle

Symptom	Possible Cause	Solution
Battery is not charging.	Tablet was removed from cradle or cradle was unplugged from AC power.	Ensure cradle is receiving power. Ensure tablet is seated correctly. Confirm main battery is charging. The battery fully charges in approximately four hours.
	Battery is faulty.	Verify that other batteries charge properly. If so, replace the faulty battery.
	The tablet is not fully seated in the cradle.	Remove and re-insert the tablet into the cradle, ensuring it is firmly seated.
	Ambient temperature of the cradle is too warm or too cold.	Move the cradle to an area where the ambient temperature is between 0°C and 40°C (32°F and 104°F).

## Communication and Charging Cradles

**Table 11** Troubleshooting the Communication and Charging Cradles

Symptom	Possible Cause	Solution
Battery is not charging.	Tablet was removed from cradle or cradle was unplugged from AC power.	Ensure cradle is receiving power. Ensure tablet is seated correctly. Confirm main battery is charging. The battery fully charges in approximately four hours.
	Battery is faulty.	Verify that other batteries charge properly. If so, replace the faulty battery.
	The tablet is not fully seated in the cradle.	Remove and re-insert the tablet into the cradle, ensuring it is firmly seated.
	Ambient temperature of the cradle is too warm or too cold.	Move the cradle to an area where the ambient temperature is between 0°C and 40°C (32°F and 104°F).

**Table 11** Troubleshooting the Communication and Charging Cradles (Continued)

Symptom	Possible Cause	Solution
During communication, no data transmits, or transmitted data was incomplete.	Tablet removed from cradle during communications.	Replace tablet in cradle and retransmit.
	Incorrect cable configuration.	Ensure that the correct cable configuration.
Tablet does not lock into cradle.	Access cover closed.	Open tablet access cover and re-insert tablet onto cradle.
	Tablet with Rugged Frame and IO Adapter does not mate with Communication and Charging Cradle.	Use Rugged Communication and Charging Cradle.

## Expansion Backs

**Table 12** Troubleshooting the Expansion Backs

Symptom	Possible Cause	Solution
Aiming laser does not display when pressing trigger.	On 8.4 in. tablet, did not remove rubber gasket during installation.	See system administrator to re-install Expansion Back.
	Tablet is in suspend mode.	Press power button to wake the tablet.
	Battery is low.	If the scanner stops emitting a laser beam upon a scan button press, check the battery level. When the battery is low, the scanner shuts off before the tablet low battery condition notification. Note: If the scanner is still not reading bar codes, contact system administrator.
Laser comes on, but scanner does not decode the bar code.	Tablet is not programmed for the bar code.	Ensure the application is programmed to read the type of bar code being scanned. Contact system administrator.
	Unreadable bar code.	Check the symbol to ensure it is not defaced. Try scanning another bar code of the same type.
	Distance between exit window and bar code is incorrect.	Move the tablet within proper scanning range.
	Scanning application is not loaded.	Load a scanning application. See the system administrator.

## 4-Slot Charge Only Cradle

**Table 13** Troubleshooting the 4-Slot Charge only Cradle

Symptom	Possible Cause	Solution
Tablet battery is not charging.	Tablet was removed from cradle or cradle was unplugged from AC power.	Ensure cradle is receiving power. Ensure tablet is seated correctly. Confirm main battery is charging. The battery fully charges in approximately four hours.
	Battery is faulty.	Verify that other tablet batteries charge properly. If so, replace the faulty battery.
	The Tablet is not fully seated in the cradle.	Remove and re-insert the tablet into the cradle, ensuring it is firmly seated. Ensure that an insert is not used with tablet with Rugged Frame. Ensure that an insert is used with tablet without Rugged Frame.
	Ambient temperature of the cradle is too warm or too cold.	Move the cradle to an area where the ambient temperature is between 0°C and 40°C (32°F and 104°F).

## Charging Adapter

**Table 14** Troubleshooting the Charging Adapter

Symptom	Possible Cause	Solution
Tablet battery is not charging.	Tablet was removed from adapter or adapter was unplugged from AC power.	Ensure adapter is receiving power. Ensure tablet is seated correctly. Confirm tablet is charging. The battery fully charges in approximately four hours.
	Battery is faulty.	Verify that other tablet batteries charge properly. If so, replace the faulty battery.
	The tablet is not fully seated in the adapter.	Remove and re-insert the tablet into the adapter, ensuring it is firmly seated.
	Ambient temperature of the adapter is too warm or too cold.	Move the adapter to an area where the ambient temperature is between 0°C and 40°C (32°F and 104°F).

## 4-Slot Battery Charger

**Table 15** Troubleshooting the 4-Slot Battery Charger

Symptom	Possible Cause	Solution
Power Pack Charging LED does not light when inserted.	Power Pack is not correctly seated.	Remove and re-insert the spare battery into the charging slot, ensuring it is correctly seated.
Power Pack is not charging.	Power Pack was removed from charger or charger was unplugged from AC power.	Ensure charger is receiving power. Ensure Power Pack is seated correctly. Confirm Power Pack is charging. The Power Pack fully charges in approximately four hours.
	Power Pack is faulty.	Verify that other Power Pack charge properly. If so, replace the faulty Power Pack.
	The Power Pack is not fully seated in the charger.	Remove and re-insert the Power Pack into the charger, ensuring it is firmly seated.
	Ambient temperature of the charger is too warm or too cold.	Move the charger to an area where the ambient temperature is between 0°C and 40°C (32°F and 104°F).

# Specifications

## Technical Specifications

For device technical specifications, go to [zebra.com/et5x](http://zebra.com/et5x).

Need device camera decode symbologies.

**Table 16** Expansion Back Supported Symbologies

Bar Code Type	Symbologies
1D	Bookland EAN, Chinese 2 of 5, Codabar, Code 11, Code 128, Code 32, Code 39, Code 93, Discrete 2 of 5, EAN-8, EAN-13, GS1-128, Interleaved 2 of 5, Inverse 1D, ISBT-128, ISSN EAN, Korean 2 of 5, MSI, Matrix 2 of 5, Trioptic Code 39, UCC Coupon Code, UPCA, UPCE, UPCE1.
2D	Aztec, Aztec Inverse, Composite AB, Composite C, Data Matrix, Data Matrix Inverse, Maxicode, Micro PDF417, Micro QR, PDF417, QR Code, QR Code Inverse, Han Xin, Han Xin Inverse
Postal	Australian Postal, Japan Postal, UK Postal, US Planet, US Postnet, Netherlands KIX Code, USPS 4CB/One Code/Intelligent Mail, UPU FICS Postal

## SE4750 Expansion Back Decode Range

**Table 17** SE4750 Decode Distances

Bar Code Type	Near Distance (in, typical)	Far Distance (in, typical)
3 mil Code 39	2.8	6.2
5 mil Code 128	2.3	8.7
5 mil PDF417	3.0	8.1
6.67mil PDF417	2.2	10.6
10 mil Data Matrix	2.4	10.6

\* Limited by width of bar code in field of view.  
Note: Photographic quality bar code at 18° tilt pitch angle under 30 fcd ambient illumination.



## Specifications

**Table 17** SE4750 Decode Distances (Continued)

Bar Code Type	Near Distance (in, typical)	Far Distance (in, typical)
100% UPCA	1.6*	23.0
15 mil Code 128	2.4*	25.2
20.0 mil Code 39	1.6*	36.3
* Limited by width of bar code in field of view. Note: Photographic quality bar code at 18° tilt pitch angle under 30 fcd ambient illumination.		

## Integrated Scanner Decode Zones

**Table 18** Integrated Scanner Decode Distances

Bar Code Type	Near Distance (in, typical)	Far Distance (in, typical)
4 mil Code 39	3.3	8.8
5 mil Code 128	2.3	8.2
5 mil Code 39	2.0	13.5
5 mil PDF417	3.1	8.4
10 mil Data Matrix	2.9	10.1
100% UPCA	1.8	26.0
20.0 mil Code 39	2.0	30.0
Note: Photographic quality bar code at 18° tilt pitch angle under 30 fcd ambient illumination.		

## Accessory Specifications

### Charge Only Cradle

**Table 19** Charge Only Cradle Technical Specifications

Feature	Description
Dimensions	Height: 7.9 cm (3.1 in.) Width: 14.2 cm (5.6 in.) Depth: 11.9 cm (4.7 in.)
Weight	550 g (19.4 oz)
Input Voltage	12 VDC
Power Consumption	60 watts
Operating Temperature	0°C to 40°C (32°F to 104°F)
Humidity	10% to 90% non-condensing
Electrostatic Discharge (ESD)	+/- 8 kV air +/- 4 kV contact

## Communication and Charging Cradle

**Table 20** Communication and Charging Cradle Technical Specifications

Feature	Description
Dimensions	Height: 7.9 cm (3.1 in.) Width: 14.2 cm (5.6 in.) Depth: 11.9 cm (4.7 in.)
Weight	550 g (19.4 oz)
Input Voltage	12 VDC
Power Consumption	60 watts
Operating Temperature	0°C to 40°C (32°F to 104°F)
Humidity	5% to 90% non-condensing
Electrostatic Discharge (ESD)	+/- 8 kV air +/- 4 kV contact

## Rugged Communication and Charging Cradle

**Table 21** Rugged Communication and Charging Cradle Technical Specifications

Feature	Description
Dimensions	Height: 7.9 cm (3.1 in.) Width: 14.2 cm (5.6 in.) Depth: 11.9 cm (4.7 in.)
Weight	550 g (19.4 oz)
Input Voltage	12 VDC
Power Consumption	60 watts
Operating Temperature	0°C to 40°C (32°F to 104°F)
Humidity	5% to 90% non-condensing
Electrostatic Discharge (ESD)	+/- 8 kV air +/- 4 kV contact

## Expansion Backs

**Table 22** 8.4 in. Expansion Back Technical Specifications

Feature	Description
Dimensions	Height: 137 mm (5.4 in.) Width: 157.5 mm (6.2 in.) Depth: 54 mm (2.1 in.)
Weight	246 g (8.7 oz)
Operating Temperature	0°C to 50°C (32°F to 122°F)
Storage Temperature	-20°C to 60°C (-40°F to 158°F)
Humidity	5% to 95% non-condensing
Drop	1.2 m (4 ft) drop to plywood over concrete per MIL-STD 810G across operating temperatures with rugged frame.
Electrostatic Discharge (ESD)	+/- 8 kV air +/- 4 kV contact

**Table 23** 8.4 in. SE4750 Expansion Back Technical Specifications

Feature	Description
Dimensions	Height: 137 mm (5.4 in.) Width: 157.5 mm (6.2 in.) Depth: 54 mm (2.1 in.)
Weight	273 g (9.6 oz)
Operating Temperature	0°C to 50°C (32°F to 122°F)
Storage Temperature	-20°C to 60°C (-40°F to 158°F)
Humidity	5% to 95% non-condensing
Drop	1.0 m (3.28 ft) drop to plywood over concrete per MIL-STD 810G across operating temperatures with rugged frame.
Electrostatic Discharge (ESD)	+/- 8 kV air +/- 4 kV contact

**Table 24** 10.1 in. Expansion Back Technical Specifications

Feature	Description
Dimensions	Height: 157.7 mm (6.2 in.) Width: 184 mm (7.2 in.) Depth: 54 mm (2.1 in.)
Weight	307 g (10.8 oz)
Operating Temperature	0°C to 50°C (32°F to 122°F)
Storage Temperature	-20°C to 60°C (-40°F to 158°F)

## Specifications

**Table 24** 10.1 in. Expansion Back Technical Specifications (Continued)

Feature	Description
Humidity	5% to 95% non-condensing
Drop	1.0 m (3.28 ft) drop to plywood over concrete per MIL-STD 810G across operating temperatures with rugged frame.
Electrostatic Discharge (ESD)	+/- 8 kV air +/- 4 kV contact

**Table 25** 10.1 in. SE4750 Expansion Back Technical Specifications

Feature	Description
Dimensions	Height: 157.7 mm (6.2 in.) Width: 184 mm (7.2 in.) Depth: 54 mm (2.1 in.)
Weight	336.5 g (11.9 oz)
Operating Temperature	0°C to 50°C (32°F to 122°F)
Storage Temperature	-20°C to 60°C (-40°F to 158°F)
Humidity	5% to 95% non-condensing
Drop	1.0 m (3.28 ft) drop to plywood over concrete per MIL-STD 810G across operating temperatures with rugged frame.
Electrostatic Discharge (ESD)	+/- 8 kV air +/- 4 kV contact

# Index

## A

accessories	
charge only cradle	58
communication and charging cradle	62
four slot charge only cradle	76
rugged communication and charging cradle	66
specifications	123
adaptive frequency hopping	47
ambient display setting	39
apn	40
approved cleanser	114
approved cleanser active ingredients	114
apps	
accessing	4
camera	7
datawedge demonstration	12
RxLogger	14
RxLogger Utility	15
sound recorder	15

## B

barcode scanning	
DS3678 digital scanner	20
battery	
low battery notification	35
monitor usage	35
battery management	34
battery level	34
battery present status	34
battery optimization	34
battery safety guidelines	113
bluetooth	37, 47
change name	50
PIN	48
power states	49
profiles	48
security	48

## C

camera	1, 7
front camera photo settings	10
front camera video settings	12
photo settings	9
rear camera photo settings	9
rear camera video settings	11
recording videos	8
taking panoramic photos	8
taking photos	7
video settings	11
camera settings	9, 11
cast	51
change bluetooth name	50
charge only cradle	58
cleaning	114, 115
battery connectors	116
frequency	115
instructions	114
materials	115
cleaning instructions	115
communication and charging cradle	62
cradles	
charge only	58
communication and charging	62
four slot charge only	76
rugged communication and charging	66

## D

data capture	12, 18
DS3678 digital scanner	20
datawedge	33
decoders	34
disabling	34
enable	34
datawedge demonstration	12
decode distances	122, 123
decoders	34
disconnect host computer	37
display	12

display settings	38
DS3678	
pairing	32
pairing using Bluetooth HID	32
pairing using simple serial interface	32
scanning	28
DS3678 digital scanner	
barcode scanning	20
data capture	20

## E

EAP	41
edit apn	40

## F

file transfer	36
font size	40
four slot charge only cradle	76

## G

general sound setting	41
getting started	21
google	
account setup	26

## H

harmful ingredients	115
home screen	28
rotation	29

## I

imager scanning	18
interactive sensor technology	27, 35

## K

keyboards	42
additional character tab	44
alpha tab	44
configuration	43
editing text	43
numeric tab	44

## L

lithium-ion battery	16
lock screen notifications	45
low battery notification	35

## M

maintenance	
approved cleanser active ingredients	114
battery safety guidelines	113
clean battery connectors	116
cleaning frequency	115
cleaning instructions	114
cleaning materials required	115
device cleaning instructions	115
harmful ingredients	115
maintaining the device	113
special cleaning notes	115
managing notifications	32
memory	12
monitor battery usage	35

## N

near field communication	37
near field communications	51
NFC	51
notational conventions	13
notification icons	30
notifications	
lock screen	45
managing	32

## O

operating system	12
------------------	----

## P

pairing	
DS3678	32
RS507/RS6000 hands-free imager	30
using Bluetooth HID (RS507/RS6000)	31
using Bluetooth HID(DS3678)	32
using simple serial interface (DS3678)	32
using simple serial interface(RS507/RS6000)	30
panoramic	8
parts of the tablet	
front view	16
photo transfer	36
photos	
camera settings	9
panoramic	8
taking	7
PTT Express	
group calls	13

## Q

quick access panel	33
--------------------	----

quick settings  
 edit icons ..... 34

## R

radios ..... 12  
 related documents ..... 13  
 related software ..... 13  
 remove wi-fi ..... 42  
 RS507  
   scanning ..... 22, 24, 25  
 RS507 hands-free imager ..... 19  
 RS507 scanning ..... 24, 25, 28, 29, 30  
 RS507/RS6000  
   pairing ..... 30  
   pairing using Bluetooth HID ..... 31  
   pairing using simple serial interface ..... 30  
 RS6000  
   bluetooth ring scanner ..... 20  
   scanning ..... 27  
 RS6000 scanning ..... 23, 27  
 rugged communication and charging cradle ..... 66  
 RxLogger ..... 14  
   configuration ..... 14  
   configuration file ..... 14  
   disable logging ..... 14  
   enable logging ..... 14  
   extract log files ..... 14  
 RxLogger Utility ..... 15

## S

scanning ..... 18  
   considerations ..... 18  
   DS3678 ..... 28  
   RS507 ..... 22, 24, 25  
   RS6000 ..... 27  
 screen blanking ..... 17  
 screen font size ..... 40  
 security ..... 41  
 setting  
   camera ..... 9, 11  
 settings ..... 38  
   accessing ..... 38  
   ambient display ..... 39  
   camera photos ..... 9  
   camera videos ..... 11  
   display ..... 38  
   general sound ..... 41  
 software version ..... 15  
 software versions ..... 14  
 sound recorder ..... 15  
 starting the tablet ..... 21  
 status bar ..... 29

## T

taking a panoramic photo ..... 8  
 technical specifications  
   accessories ..... 123  
 transferring files using USB ..... 36  
 troubleshooting ..... 117

## U

unpacking ..... 16  
 USB ..... 36

## V

VC Settings  
   screen blanking ..... 17  
 videos  
   camera settings ..... 11  
   recording ..... 8

## W

WEP ..... 41  
 Wi-Fi direct ..... 47  
 wireless local area network ..... 37  
 wireless wide area network ..... 37  
 WLAN ..... 37  
 WLAN 802.11a/b/g/n ..... 12, 13  
 WPA ..... 41  
 WPAN Bluetooth ..... 12, 13  
 WWAN ..... 37

