

INSTALLATION INSTRUCTIONS

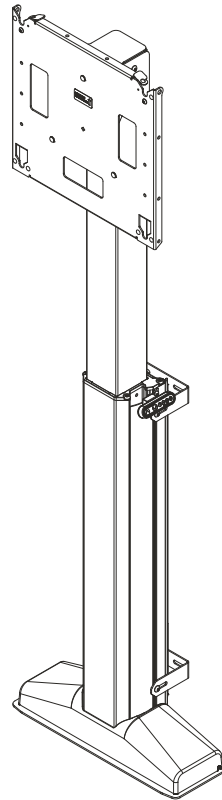

Electrical Height Adjustable Video Stand

CHIEF[®]

A brand of  legrand

LFE1U

DISCLAIMER

Legrand | AV and its affiliated corporations and subsidiaries (collectively "Legrand | AV"), intend to make this manual accurate and complete. However, Legrand | AV makes no claim that the information contained herein covers all details, conditions or variations, nor does it provide for every possible contingency in connection with the installation or use of this product. The information contained in this document is subject to change without notice or obligation of any kind. Legrand | AV makes no representation of warranty, expressed or implied, regarding the information contained herein. Legrand | AV assumes no responsibility for accuracy, completeness or sufficiency of the information contained in this document.

Chief® is a registered trademark of Legrand AV Inc.

DEFINITIONS

⚠ WARNING alerts you to the possibility of serious injury or death if you do not follow the instructions.

⚠ CAUTION alerts you to the possibility of damage or destruction of equipment if you do not follow the corresponding instructions.

⚠ DANGER alerts you to an imminently hazardous situation which, if not avoided, will result in death or serious injury.

MOUNTING SYSTEM: A MOUNTING SYSTEM is the primary Chief product to which an accessory and/or component is attached.

ACCESSORY: AN ACCESSORY is the secondary Chief product which is attached to a primary Chief product, and may have a component attached or setting on it.

COMPONENT: A COMPONENT is an audiovisual item designed to be attached or resting on an accessory or mounting system such as a video camera, CPU, screen, display, projector, etc.

⚠ IMPORTANT SAFETY INSTRUCTIONS

WARNING: FAILURE TO READ AND FOLLOW THE FOLLOWING INSTRUCTIONS CAN RESULT IN SERIOUS PERSONAL INJURY, DAMAGE TO EQUIPMENT OR VOIDING OF FACTORY WARRANTY. It is the installer's responsibility to make sure all components are properly assembled and installed using the instructions provided.

When using an electrical mounting system, basic precautions should always be followed, including the following:

READ ALL INSTRUCTIONS BEFORE USING THIS PRODUCT!!!!

⚠ DANGER: TO REDUCE THE RISK OF ELECTRIC SHOCK:

1. Always turn off power at source before cleaning.

⚠ WARNING: TO REDUCE THE RISK OF BURNS, FIRE, ELECTRIC SHOCK, OR INJURY TO PERSONS:

1. Unplug from outlet before putting on or taking off parts.
2. Close supervision is necessary when this furnishing is used by, or near children, invalids, or disabled persons.
3. Use this furnishing only for its intended use as described in these instructions. Do not use attachments not recommended by the manufacturer.
4. Never operate this mounting system if it has a damaged cord or plug, if it is not working properly, if it has been dropped or damaged, or dropped into water. Return the mounting system to a service center for examination and repair.
5. Keep the cord away from heated surfaces.
6. Never operate the furnishing with the air openings blocked. Keep the air openings free of lint, hair, and the like.
7. Never drop or insert any object into any opening.
8. Do not use outdoors.
9. Do not operate where aerosol (spray) products are being used or where oxygen is being administered.
10. To disconnect, turn all controls to the off position, then remove plug from outlet.
11. For loading always put heavier items at the bottom and not near the top in order to help prevent the possibility of the furnishing tipping over.

⚠ WARNING: Exceeding the weight capacity can result in serious personal injury or damage to equipment! It is the installer's responsibility to make sure the weight of all components attached to the LFE1U does not exceed 200 lbs (90.7 kg).

⚠ WARNING: Use this mounting system only for its intended use as described in these instructions. Do not use attachments not recommended by the manufacturer.

⚠ WARNING: Never operate this mounting system if it is damaged. Return the mounting system to a service center for examination and repair.

⚠ WARNING: RISK OF SERIOUS INJURY OR DEATH! Risk of death or serious injury may occur when children climb on audio and/or video equipment furniture. A remote control or toys placed on the furnishing may encourage a child to climb on the furnishing and as a result the furnishing may tip over on to the child.

⚠️ WARNING: RISK OF SERIOUS INJURY OR DEATH! Relocating audio and/or video equipment to furniture not specifically designed to support audio and/or video equipment may result in death or serious injury due to the furnishing collapsing or overturning onto a child.

NOTE: The LFE1U stand has no user serviceable parts.

NOTE: The LFE1U stand can support screen sizes up to a maximum of 86".

NOTE: The LFE1U stand is intended for Institutional Use.

NOTE: To reduce the risk of electric shock, this furnishing has a polarized plug (one blade is wider than the other). This plug will fit in a polarized outlet only one way. If the plug does not fit fully in the outlet, reverse the plug. If it still does not fit, contact a qualified electrician to install the proper outlet. Do not change the plug in any way.

NOTE: This product is a double-insulated, cord-connected product and must be serviced accordingly. In a double-insulated product, two systems of insulation are provided instead of grounding. No grounding means for grounding to be added to the product. Servicing a double-insulated product requires extreme care and knowledge of the system, and is to be done only by qualified service personnel. Replacement parts for a double-insulated product must be identical to the parts they replace. A double-insulated product is marked with the symbol (square within a square)

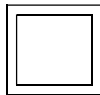

Electrical Specifications	
Input voltage, frequency	100-240 V~, 50-60 Hz, 450W
Duty Cycle	Intermittent: 10%; max 2 minutes on/18 minutes off

NOTE: This equipment has been tested and found to comply with the limits for a Class B digital device, pursuant to Part 15 of the FCC Rules. These limits are designed to provide reasonable protection against harmful interference in a residential installation. This equipment generates, uses and can radiate radio frequency energy and, if not installed and used in accordance with the instructions, may cause harmful interference to radio communications. However, there is no guarantee that interference will not occur in a particular installation. If this equipment does cause harmful interference to radio or television reception, which can be determined by turning the equipment off and on, the user is encouraged to try to correct the interference by one or more of the following measures:

- Reorient or relocate the receiving antenna.
- Increase the separation between the equipment and receiver.
- Connect the equipment into an outlet on a circuit

different from that to which the receiver is connected.

- Consult the dealer or an experienced radio/TV technician for help.

IMPORTANT ! : The LFE1U is designed to be mounted to:

- a bare concrete wall with a minimum thickness of 8" (203mm):
- a bare 8" x 8" x 16" (203mm x 203mm x 406mm) concrete block wall; or
- a wood stud wall with a maximum drywall covering of 5/8".
- a 2" x 4"-25ga minimum steel stud wall.

IMPORTANT ! : Mounting with hardware to the finished floor is optional, however the LFE1U CANNOT be mounted exclusively to the floor without also being attached to the wall!

IMPORTANT ! : The LFE1U must be sitting on the floor after it is mounted to the wall. It CANNOT be elevated off the floor!

⚠️ CAUTION: Changes or modifications to this unit not expressly approved by the manufacturer can void the units FCC compliance rating and make the unit illegal to operate.

Responsible Party:

Legrand | AV
 6436 City West Parkway
 Eden Prairie, MN 55344
 866-977-3901
 av.support@legrand.com







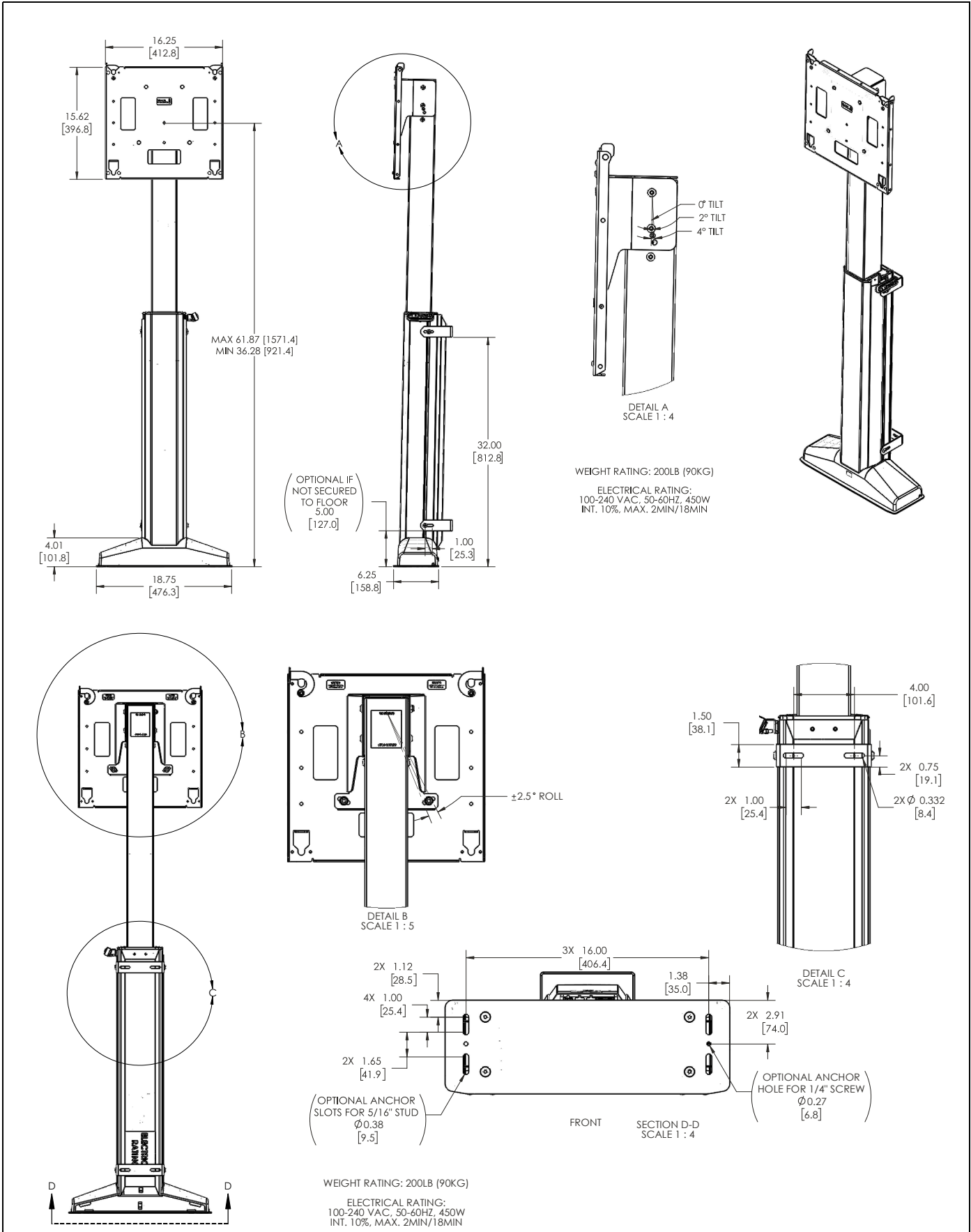



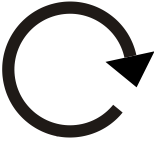

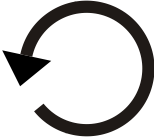
CAN ICES-3 (B)/NMB-3(B)

--SAVE THESE INSTRUCTIONS--

DIMENSIONS



LEGEND

	<p>Tighten Fastener</p> <p>Apretar elemento de fijación</p> <p>Befestigungsteil festziehen</p> <p>Apertar fixador</p> <p>Serrare il fissaggio</p> <p>Bevestiging vastdraaien</p> <p>Serrez les fixations</p>		<p>Pencil Mark</p> <p>Marcar con lápiz</p> <p>Stiftmarkierung</p> <p>Marcar com lápis</p> <p>Segno a matita</p> <p>Potloodmerkten</p> <p>Marquage au crayon</p>
	<p>Loosen Fastener</p> <p>Aflojar elemento de fijación</p> <p>Befestigungsteil lösen</p> <p>Desapertar fixador</p> <p>Allentare il fissaggio</p> <p>Bevestiging losdraaien</p> <p>Desserrez les fixations</p>		<p>Drill Hole</p> <p>Perforar</p> <p>Bohrloch</p> <p>Fazer furo</p> <p>Praticare un foro</p> <p>Gat boren</p> <p>Percez un trou</p>
	<p>Phillips Screwdriver</p> <p>Destornillador Phillips</p> <p>Kreuzschlitzschraubendreher</p> <p>Chave de fendas Phillips</p> <p>Cacciavite a stella</p> <p>Kruiskopschroevendraaier</p> <p>Tournevis à pointe cruciforme</p>		<p>Adjust</p> <p>Ajustar</p> <p>Einstellen</p> <p>Ajustar</p> <p>Regolare</p> <p>Afstellen</p> <p>Ajuster</p>
	<p>Open-Ended Wrench</p> <p>Llave de boca</p> <p>Gabelschlüssel</p> <p>Chave de bocas</p> <p>Chiave a punte aperte</p> <p>Steeksleutel</p> <p>Clé à fourche</p>		<p>Remove</p> <p>Quitar</p> <p>Entfernen</p> <p>Remover</p> <p>Rimuovere</p> <p>Verwijderen</p> <p>Retirez</p>
	<p>By Hand</p> <p>A mano</p> <p>Von Hand</p> <p>Com a mão</p> <p>A mano</p> <p>Met de hand</p> <p>À la main</p>		<p>Optional</p> <p>Opcional</p> <p>Optional</p> <p>Opcional</p> <p>Opzionale</p> <p>Optie</p> <p>En option</p>
	<p>Hex-Head Wrench</p> <p>Llave de cabeza hexagonal</p> <p>Sechskantschlüssel</p> <p>Chave de cabeça sextavada</p> <p>Chiave esagonale</p> <p>Zeskantsleutel</p> <p>Clé à tête hexagonale</p>		<p>Security Wrench</p> <p>Llave de seguridad</p> <p>Sicherheitsschlüssel</p> <p>Chave de segurança</p> <p>Chiave di sicurezza</p> <p>Veiligheidsleutel</p> <p>Clé de sécurité</p>

TOOLS REQUIRED FOR INSTALLATION

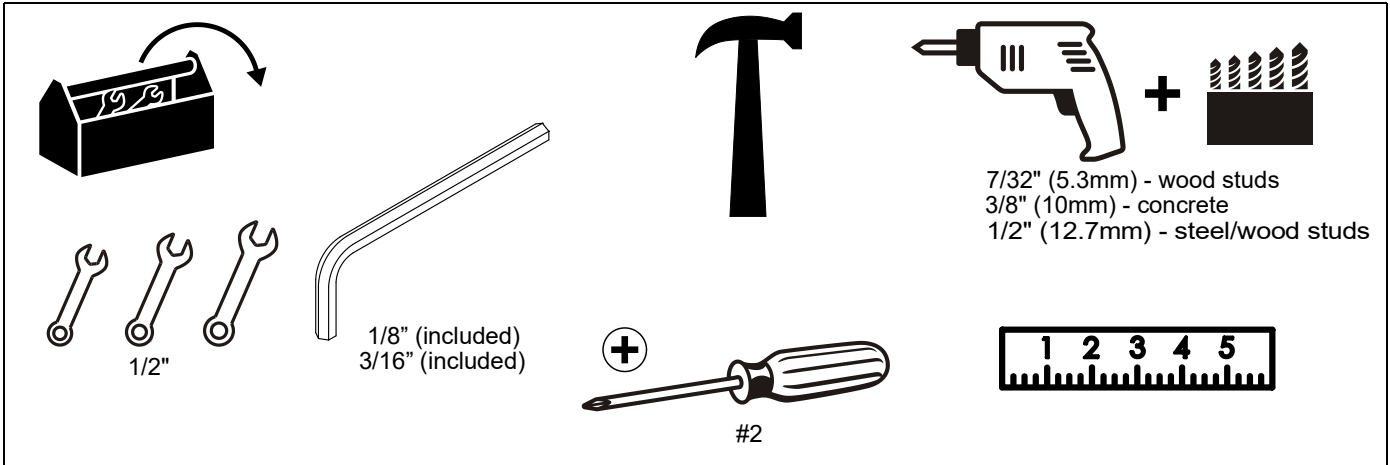

PARTS

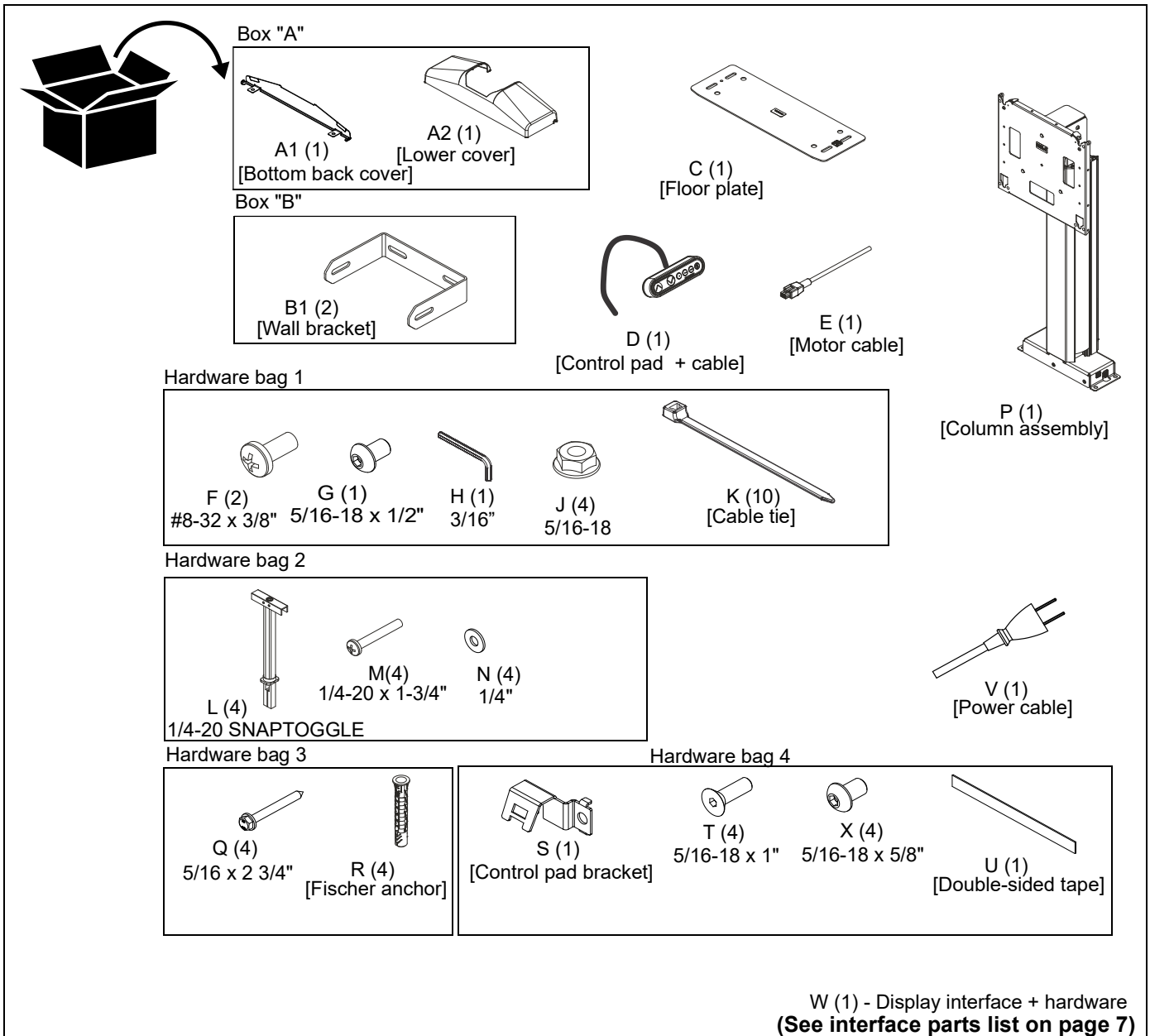



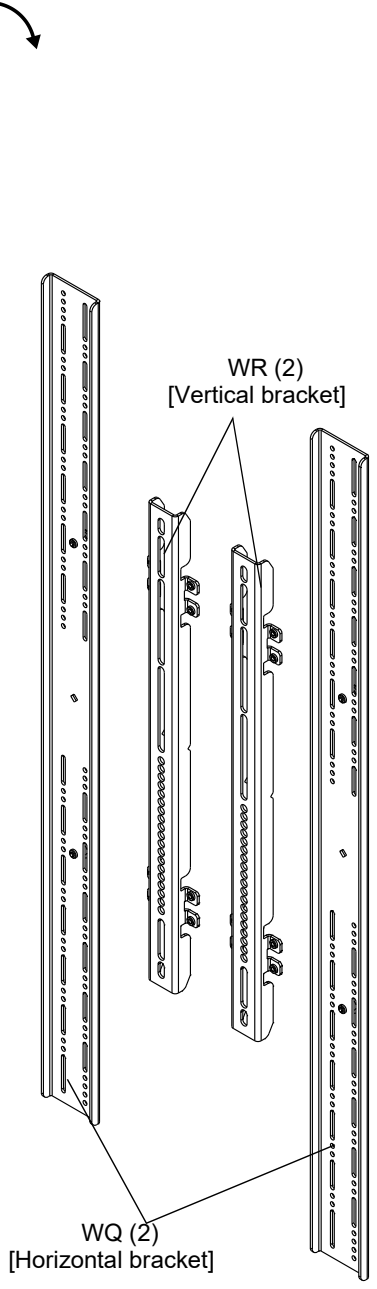











PARTS - DISPLAY INTERFACE





WR (2)
[Vertical bracket]

WQ (2)
[Horizontal bracket]

Hardware Kit

Bag A  WA (4) M4 x 12mm	Bag B  WB (4) M4 x 20mm	Bag C  WC (4) M4 x 25mm
Bag D  WD (4) M5 x 12mm	Bag E  WE (4) M5 x 20mm	Bag F  WF (4) M5 x 25mm
Bag G  WG (4) M6 x 12mm	Bag H  WH (4) M6 x 20mm	Bag I  WI (4) M6 x 25mm
Bag J  WJ (4) M8 x 12mm	Bag K  WK (4) M8 x 20mm	Bag L  WL (4) M8 x 30mm
Bag M <div style="display: flex; justify-content: space-around; align-items: center;"> <div style="text-align: center;">  WMA (8) [Nesting spacer] </div> <div style="text-align: center;">  WMB (4) [Universal spacer] </div> </div>		

 WN (8)
 #10-24 x 1/2"

 WP (1)
 1/8"

Assembly And Installation

IMPORTANT ! : The LFE1U packaging was designed to help make the installation and setup easier. Do NOT remove assembly prior to reading installation instructions!

Cart Assembly

1. Remove all boxes and smaller parts. Leave foam packaging and other cardboard pieces inside to provide stability while performing Steps 2-4. (See Figure 1)
2. Lift column assembly (P) up by lifting at the bottom of the assembly. (See Figure 1)
3. Carefully set column assembly (P) base on the edge of box. (See Figure 1)

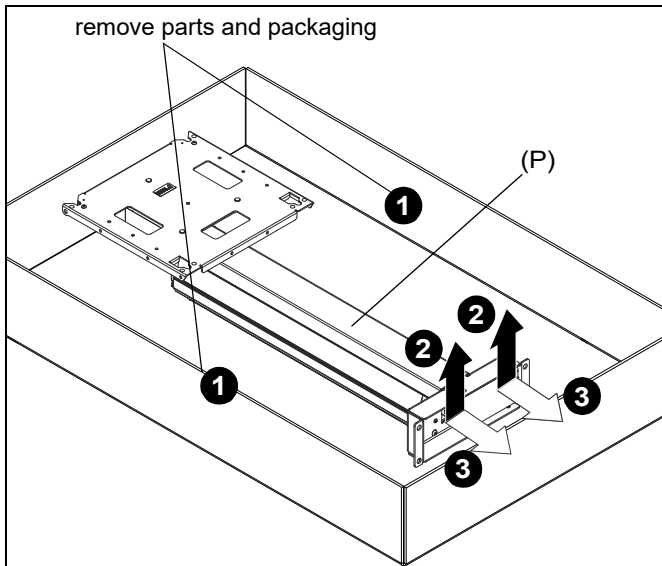

Figure 1

4. Use four 5/16-18 x 1" flat head cap screws (T) and four 5/16-18" hex nuts (J) to secure floor plate (C) to column assembly (P) and bottom back cover (A1). (See Figure 2)

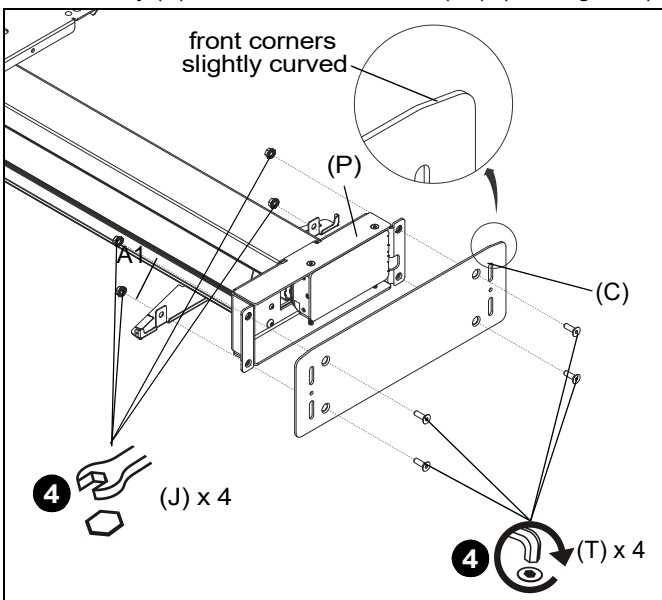

Figure 2

5. Remove stand from box by tipping it from the top onto the floor plate. (See Figure 3)

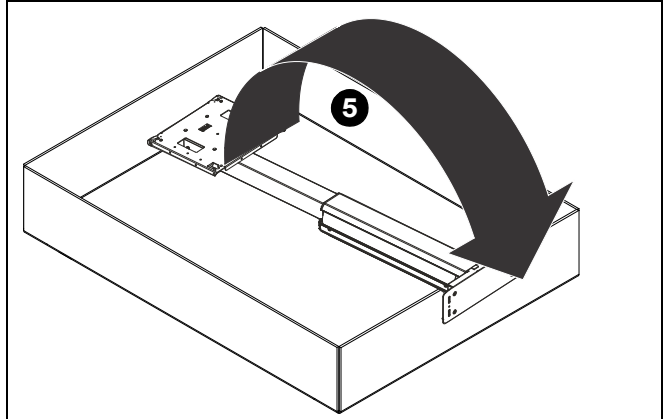

Figure 3

6. Attach control pad bracket (S) to column assembly (P) using 5/16-18 x 1/2" button head cap screw (G). (See Figure 4)

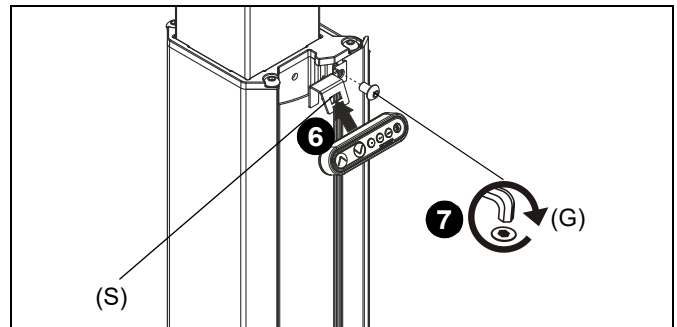

Figure 4

7. Secure control pad (D) into control pad bracket (S). (See Figure 5)

NOTE: Control pad may also be attached to bottom of display using double-sided tape (U) after display has been installed.

8. Route control pad cable (D) through side channel. (See Figure 5) and (See Figure 6)

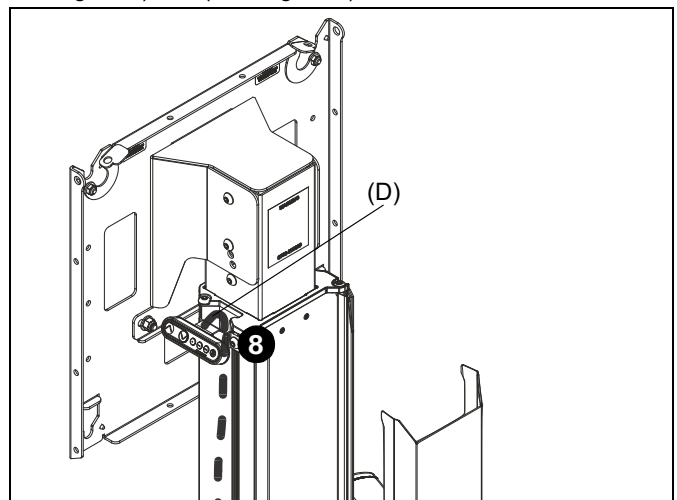

Figure 5

9. Remove back cover to expose control box. (See Figure 6)
10. Route control pad cable (D) behind bottom back cover (A1) and into port A1 on control box. (See Figure 6) and (See Figure 7)
11. Route motor cable (E) behind bottom back cover (A1) and into port 1 on control box. (See Figure 6) and (See Figure 7)

NOTE: Bottom back cover (A1) may need to be pulled back or loosened in order to fit cables behind it.

NOTE: Use cable ties (K) and pre-installed cable clips to provide tension relief.

NOTE: Knockout holes can be created on A1 bracket for another cable routing option. (See Figure 7)

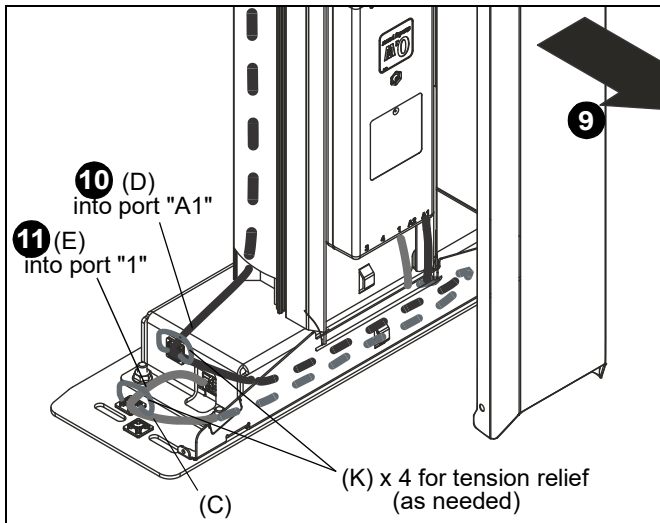

Figure 6

IMPORTANT ! : Lower cover (A2) should only be installed after all cables have been routed with no load.

12. Slide lower cover (A2) onto column assembly (P) and use two 8-32 x 3/8" Phillips pan machine screws (F) to secure bottom back cover (A1) to lower cover (A2). (See Figure 7)

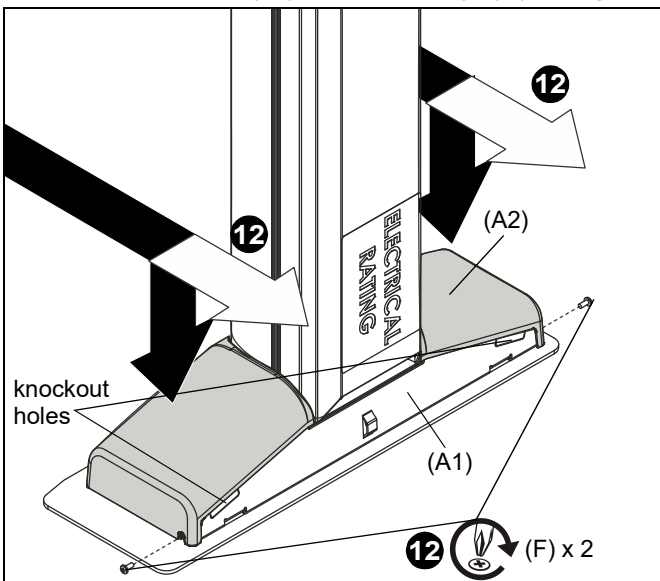

Figure 7

13. Plug in power cable (V) to control box and route along side of control box. Provide strain relief using the cable ties (K) and cable clips. All three cable clips **MUST** be used to prevent cable from rubbing against lower edge of cover! (See Figure 8)

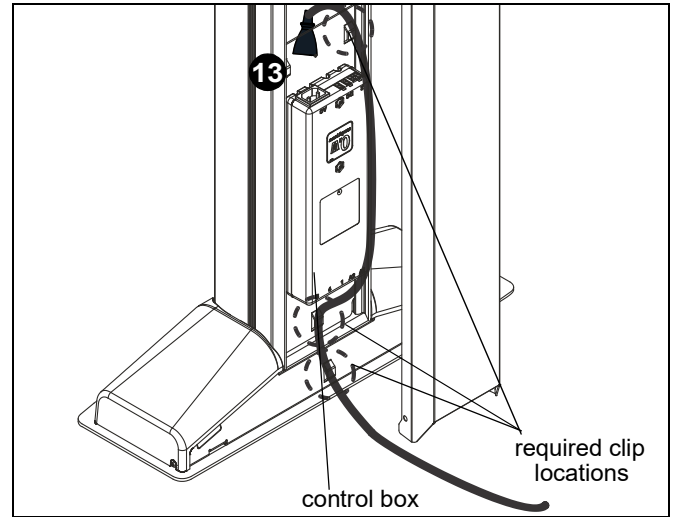

Figure 8

14. Plug in power cable (V) to outlet.
15. Press and hold "DOWN" button for three seconds to initialize lift mechanism. (See Figure 9)
16. Press and hold "UP" button until mount reaches it's maximum height. (See Figure 9)

NOTE: If lifting mechanism does not function properly refer to "Troubleshooting" Section.

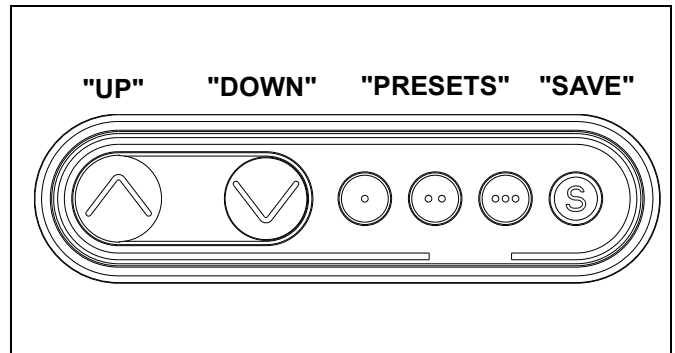

Figure 9

17. Attach display and signal cables to power source. Use cable ties (K) to route as necessary. (See Figure 10)

IMPORTANT ! : Do not install display at this time, only route the cables through the back cover.

IMPORTANT ! : Make sure to install cables when lift is at the highest position and so that there is enough length to reach input locations for display and signal.

18. Reinstall back cover to column assembly (P). (See Figure 10)

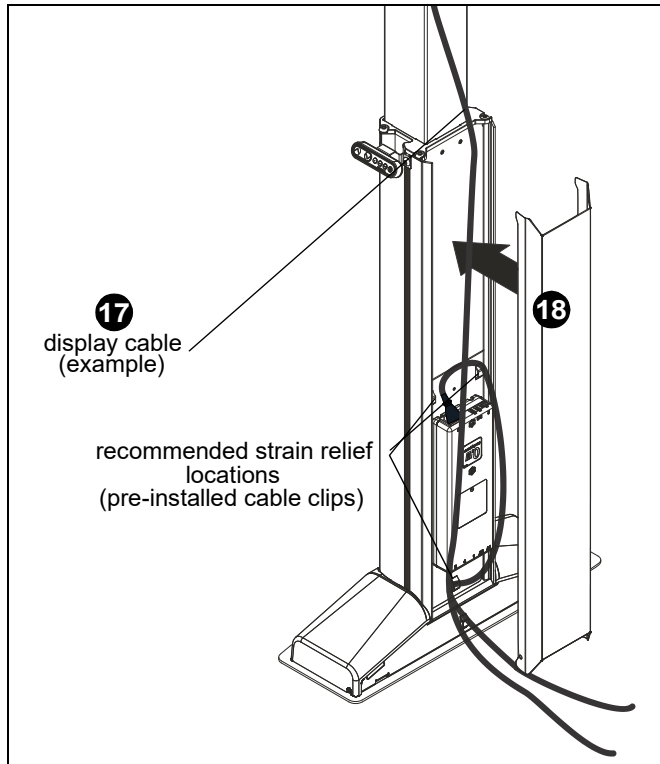

Figure 10

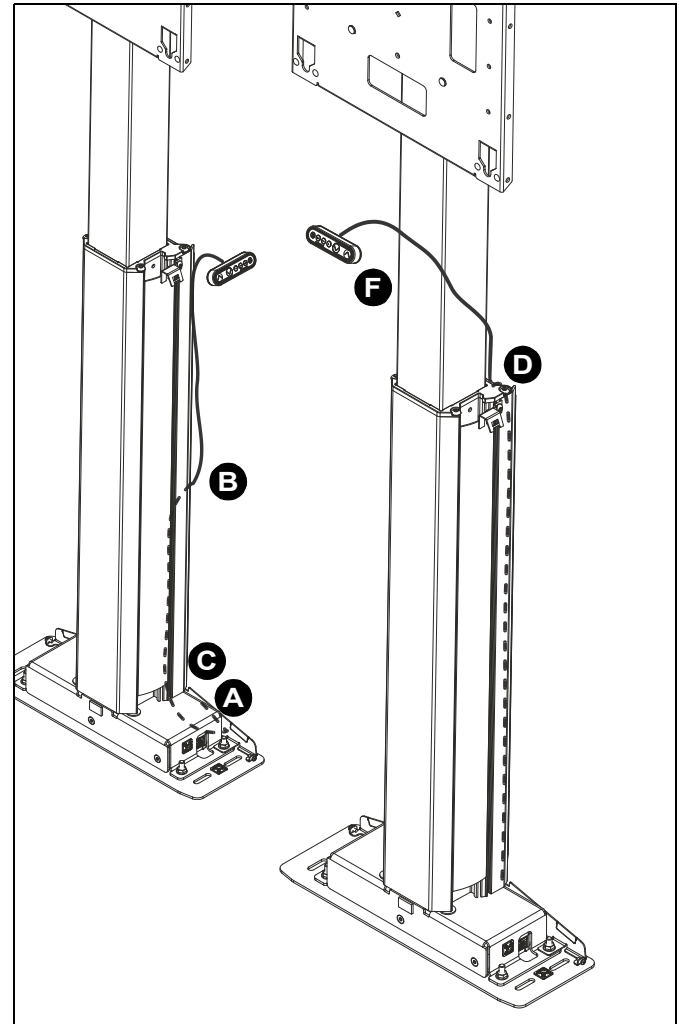

Figure 11

19. (Optional) Relocate control pad to the front center of display if desired following these steps. (See Figure 11) and (See Figure 12)

IMPORTANT ! : Make sure to perform these steps when lift is at the highest position and so that there is enough length for cable to reach control box.

- A. Unplug control pad cable from the RJ45 port in the control box.
- B. Remove cable through side cable cover.
- C. Pull cable out through opening at bottom of cable cover.
- D. Feed removed cable down through back channel.
- E. Plug cable back into control box into A1 port.
- F. Use double-sided foam tape (U) to attach control pad to bottom of display in the center.

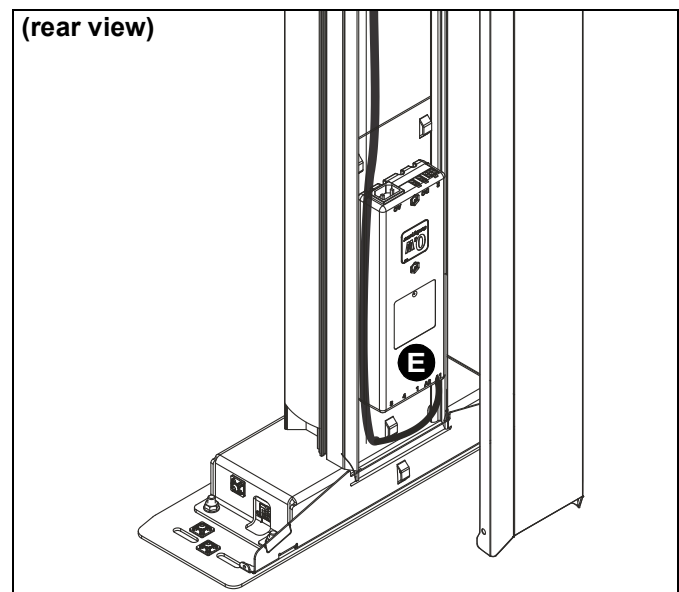

Figure 12

Installation to Wall

IMPORTANT ! : The LFE1U is designed to be mounted to:

- a bare concrete wall with a minimum thickness of 8" (203mm);
- a bare 8" x 8" x 16" (203mm x 203mm x 406mm) concrete block wall; or
- a wood stud with a maximum drywall covering of 5/8".
- a 2" x 4"-25ga minimum steel stud wall.

Installing to Wood Stud Wall

1. Use a stud-finder to locate stud.
2. Measure 5 5/8" off the finished floor to mark lower mounting locations and 32 5/8" off the finished floor for upper mounting locations with one of the locations being centered on stud. Holes must be 4" apart horizontally. (See Figure 13)
3. Mark hole locations at each mounting location. (See Figure 13)
4. Drill two 7/32" holes at marked hole locations on studs. (See Figure 13)
5. Drill two 1/2" holes on marked hole locations NOT on stud. (See Figure 13)

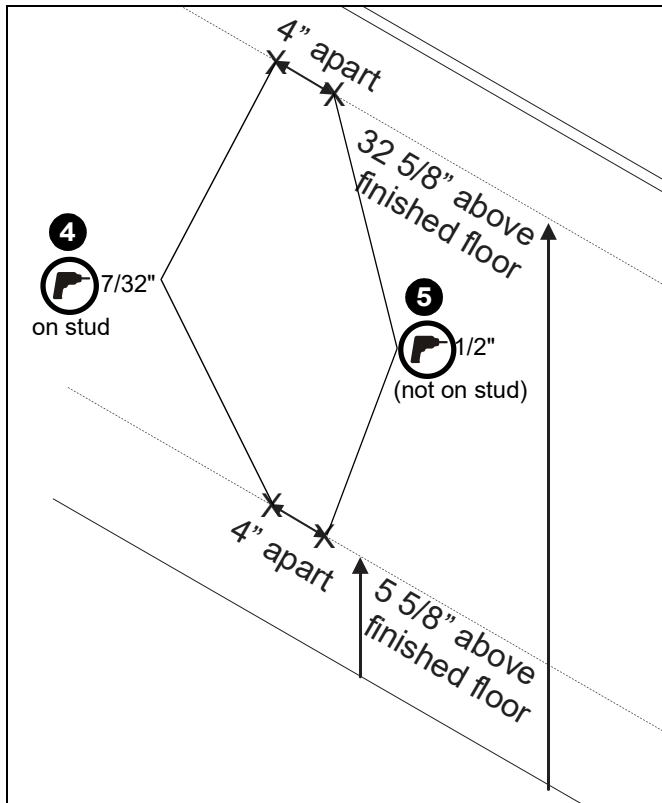

Figure 13

6. Follow Steps 7-10 to install toggler anchors into two drywall holes (not on stud).
7. Hold metal channel on anchor (L) flat alongside plastic straps and slide channel through hole. (See Figure 14)

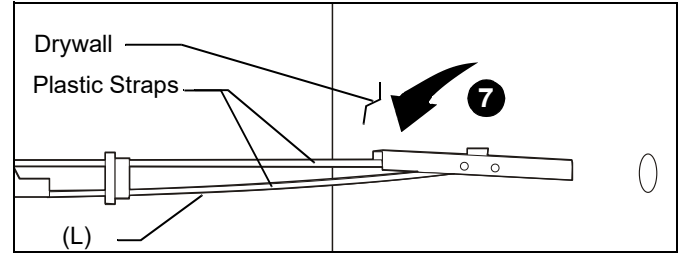

Figure 14

8. Holding plastic straps on anchor (L), pull anchor away from wall until channel rests flush behind wall making sure anchor channel is positioned vertically on stud. (See Figure 15)
9. Slide plastic cap on anchor (L) towards wall until flange of cap is flush with wall. (See Figure 15)

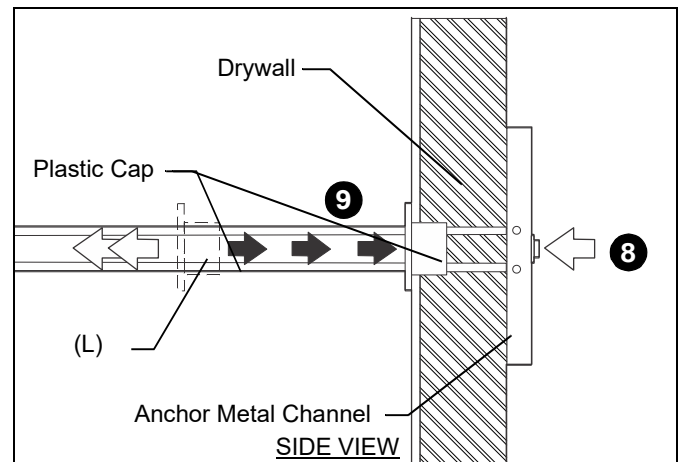

Figure 15

10. Snap off plastic straps on anchor at wall by pushing side to side, snapping off straps level with flange of plastic cap. (See Figure 16)

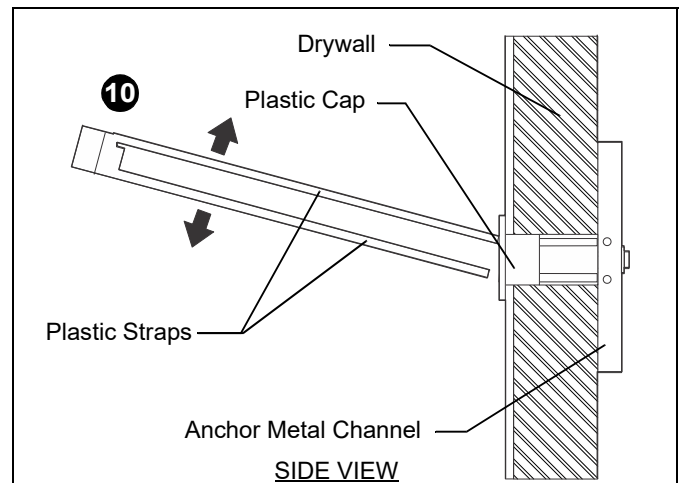

Figure 16

11. Repeat Steps 7 through 10 for the other mounting hole not on stud.

12. Place wall brackets (B1) over anchors and drilled holes and align mounting slots on mount with holes in anchors and wall. (See Figure 17)
13. Install two 5/16 x 2 3/4" hex head tapping bolts (Q) through corresponding mounting slots on mount and into drilled holes on wood stud. DO NOT overtighten! (See Figure 17)
14. Install two 1/4-20 x 1-3/4" Phillips pan machine screws (M) through 1/4" washers (N) and slots on wall bracket (B1) and into toggler anchors (L). (See Figure 17)
15. Position column assembly (P) inside two installed wall brackets (B1). (See Figure 17)

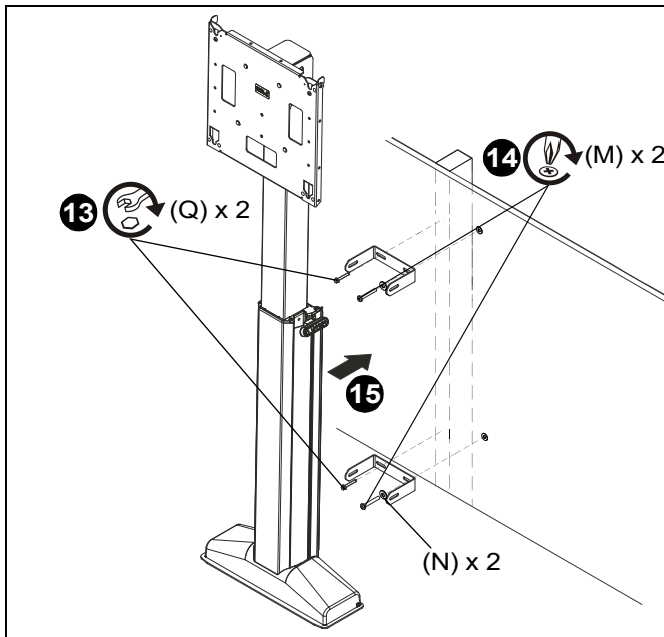

Figure 17

16. Install four 5/16-18 x 5/8" button head cap screws (X) through holes on wall brackets (B1) and side of column assembly (P). (See Figure 18)

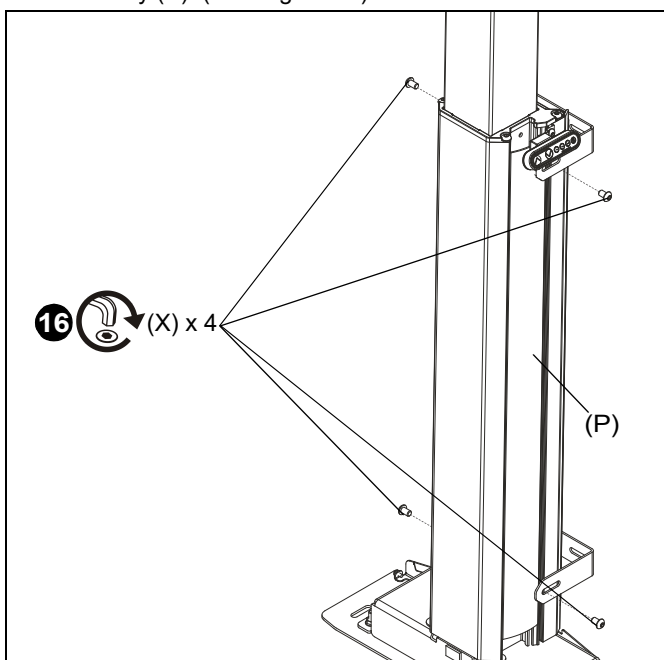

Figure 18

Installing to Steel Stud Wall

Site Requirements (Steel Studs)

16" (on center) Studs
LFE1U Installation Location



If back side of wall is unfinished, drywall must be installed to a minimum of one stud left and right of the studs being used to install the mount. Drywall must be secured to studs with screws 12" on center

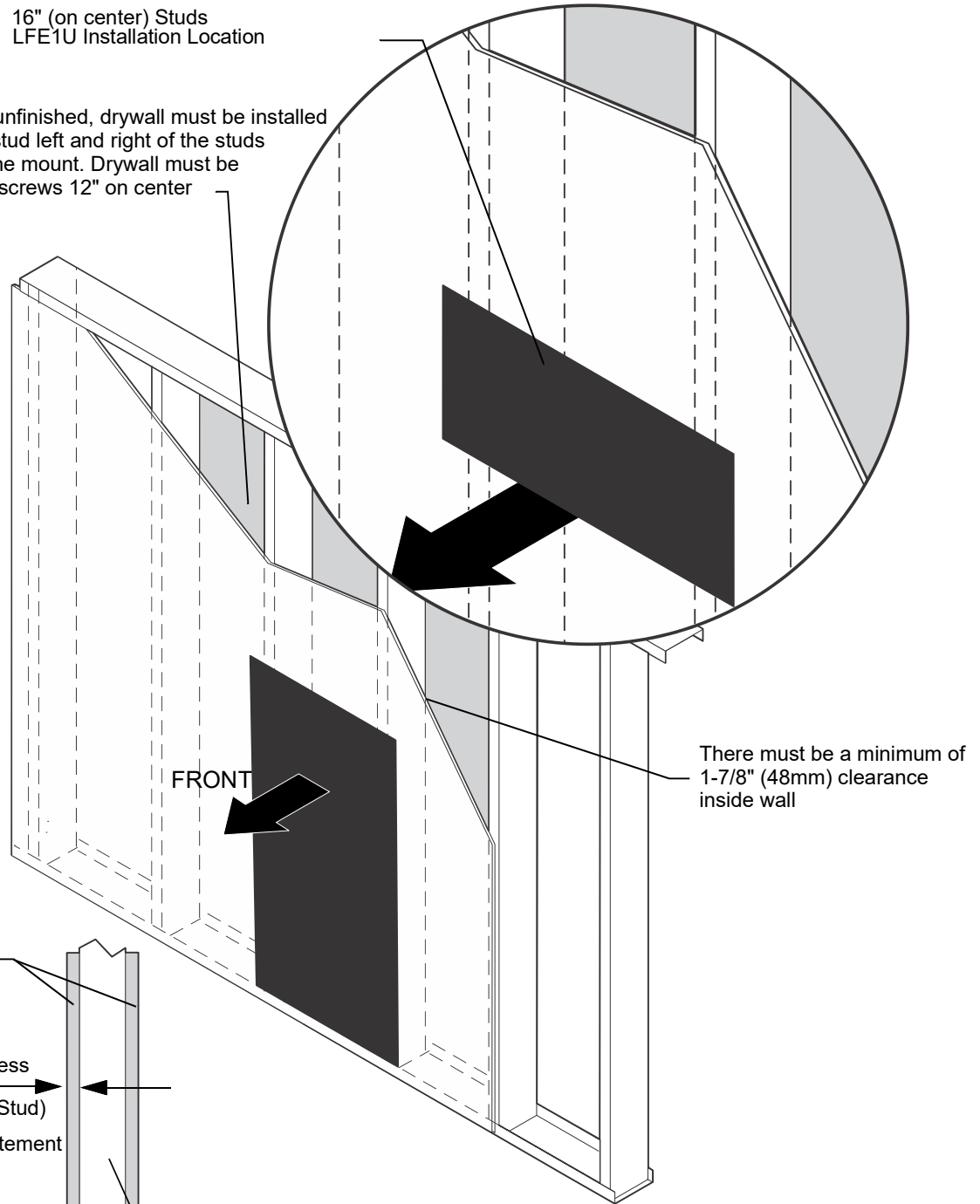

Drywall
**1/2" minimum
Drywall Thickness
(Both Sides of Stud)

**See hazard statement
on page 2!

Steel Stud (2 x 4 / 25ga minimum)
Stud type and structural strength must conform to the North American
Specification for the Design of Cold-Formed Steel Structural Members.
[362, 125 18, C-Shape, S - Stud Section]

1. Measure 5 5/8" off the finished floor to mark lower mounting locations and 32 5/8" off the finished floor for upper mounting locations with one of the locations being centered on stud. Holes must be 4" apart horizontally. (See Figure 19)
2. Mark hole locations at each mounting location. (See Figure 19)
3. Drill two 1/2" holes at marked hole locations on stud. (See Figure 19)
4. Drill two 1/2" holes on marked hole locations NOT on stud. (See Figure 19)

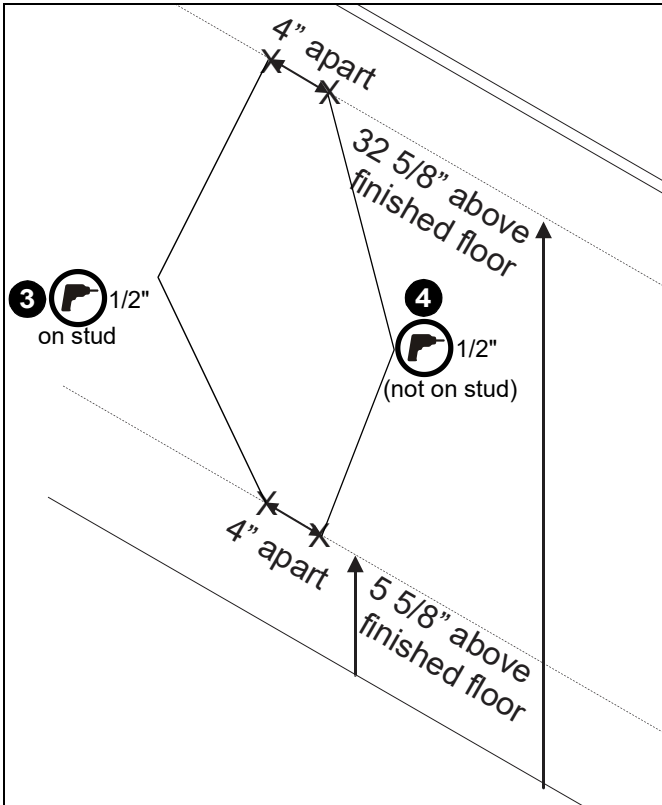

Figure 19

5. Hold metal channel on anchor (L) flat alongside plastic straps and slide channel through hole. (See Figure 20)

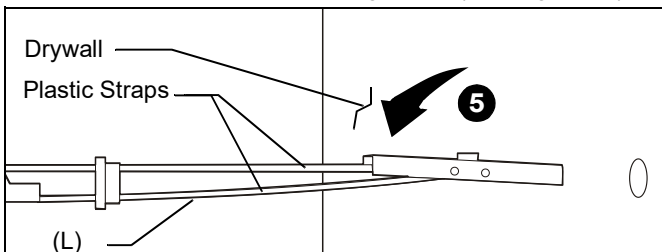

Figure 20

6. Holding plastic straps on anchor (L), pull anchor away from wall until channel rests flush behind wall making sure anchor channel is positioned vertically on stud. (See Figure 21)
7. Slide plastic cap on anchor (L) towards wall until flange of cap is flush with wall. (See Figure 21)

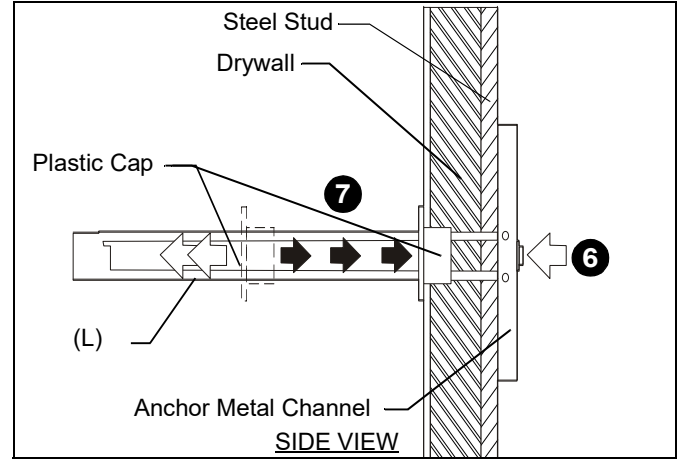

Figure 21

8. Snap off plastic straps on anchor at wall by pushing side to side, snapping off straps level with flange of plastic cap. (See Figure 22)

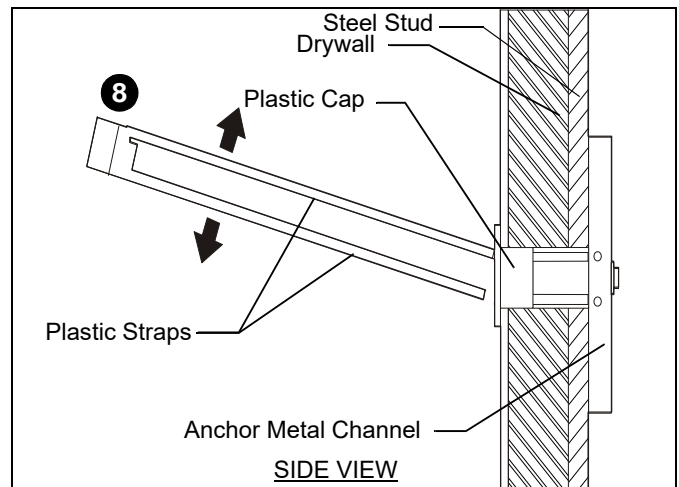

Figure 22

9. Repeat Steps 5 through 8 for the other mounting holes.

10. Place wall brackets (B1) over anchors and align mounting slots on mount with holes in anchors. (See Figure 23)
11. Install four 1/4-20 x 1-3/4" Phillips pan machine screws (M) through 1/4" washers (N) and slots on wall bracket (B1) and into toggler anchors (L). (See Figure 23)



WARNING: IMPROPER INSTALLATION CAN LEAD TO EQUIPMENT FALLING CAUSING SERIOUS PERSONAL INJURY OR DAMAGE TO EQUIPMENT! Overtightening of mounting hardware can damage the steel studs. DO NOT overtighten mounting hardware!

12. Position column assembly (P) inside two installed wall brackets (B1). (See Figure 23)

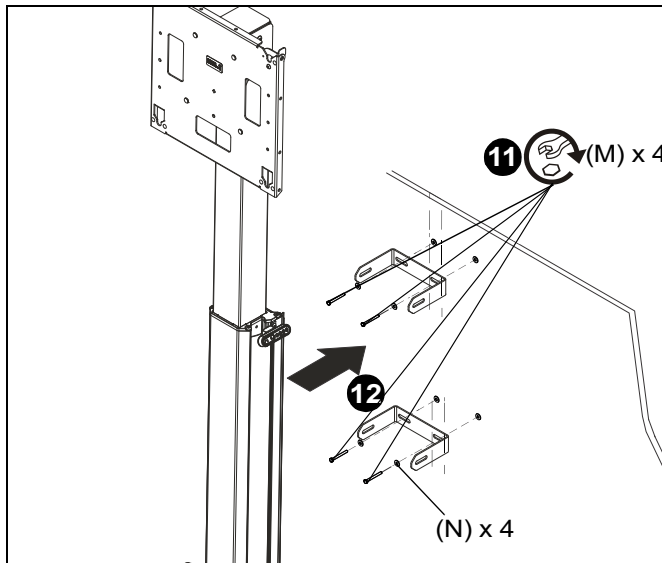

Figure 23

13. Install four 5/16-18 x 5/8" button head cap screws (X) through slots on wall brackets (B1) and side of column assembly (P). (See Figure 24)

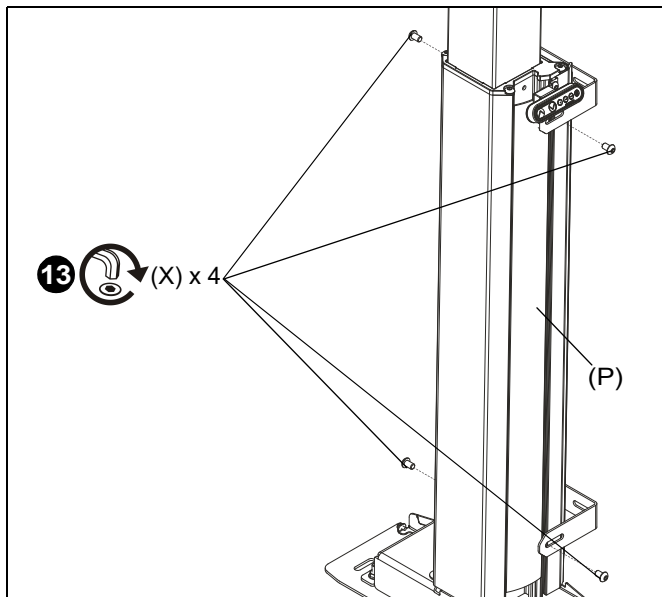

Figure 24

Installing to a Concrete Wall

1. Measure 5 5/8" off the finished floor to mark lower mounting locations and 32 5/8" off the finished floor for upper mounting locations. Holes must be 4" apart horizontally.
2. Mark hole locations at each mounting location. (See Figure 25)
3. Drill four 3/8" holes at marked hole locations. (See Figure 25)

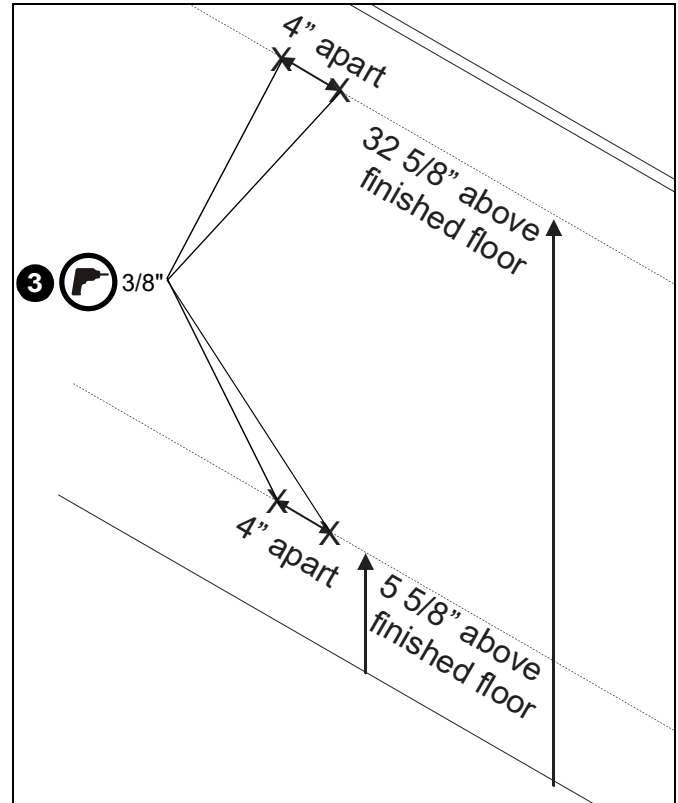

Figure 25

4. Install four concrete anchors (R) into drilled holes. (See Figure 26)
5. Use four 5/16 x 2 3/4" flange head screws (Q) to secure two wall brackets (B1) to wall. (See Figure 26)

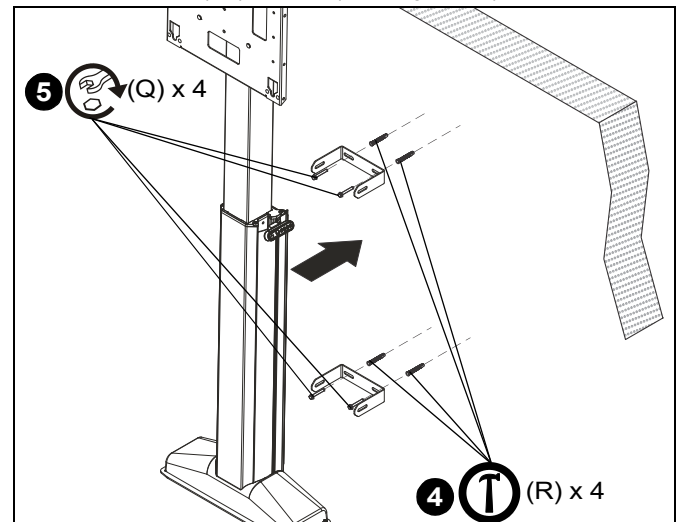

Figure 26

- Install four 5/16-18 x 5/8" button head cap screws (X) through slots on wall brackets (B1) and side of column assembly (P). (See Figure 27)

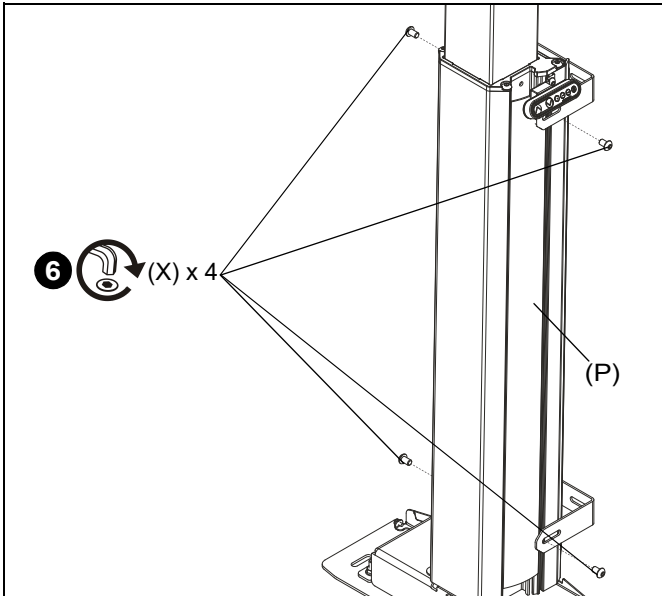
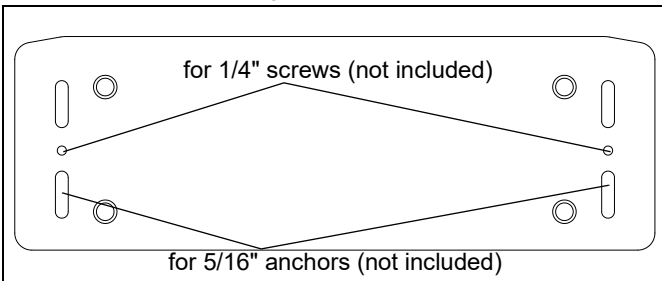

Figure 27

Securing with Hardware to Floor (Optional)

The LFE1U can be mounted to the floor for additional support and security, however it CANNOT be installed to the floor ONLY without being also attached to a wall. No hardware is provided for supplemental mounting to the floor.



Display Installation



WARNING: Exceeding the weight capacity can result in serious personal injury or damage to equipment! It is the installer's responsibility to make sure the weight of all components attached to the LFE1U does not exceed 200 lbs (90.7 kg).

- Make sure height is at the lowest possible position.
- Make sure latching flags are in "open" position.



WARNING: IMPROPER INSTALLATION CAN LEAD TO MOUNT FALLING CAUSING SERIOUS PERSONAL INJURY OR DAMAGE TO EQUIPMENT! DO NOT substitute hardware. Only use hardware provided or specified by manufacturer.

- Determine and mark the vertical center position between the Left side Upper and Lower mounting holes in display. (See Figure 28)

- Determine and mark the vertical center position between the Right side Upper and Lower mounting holes in display. (See Figure 28)

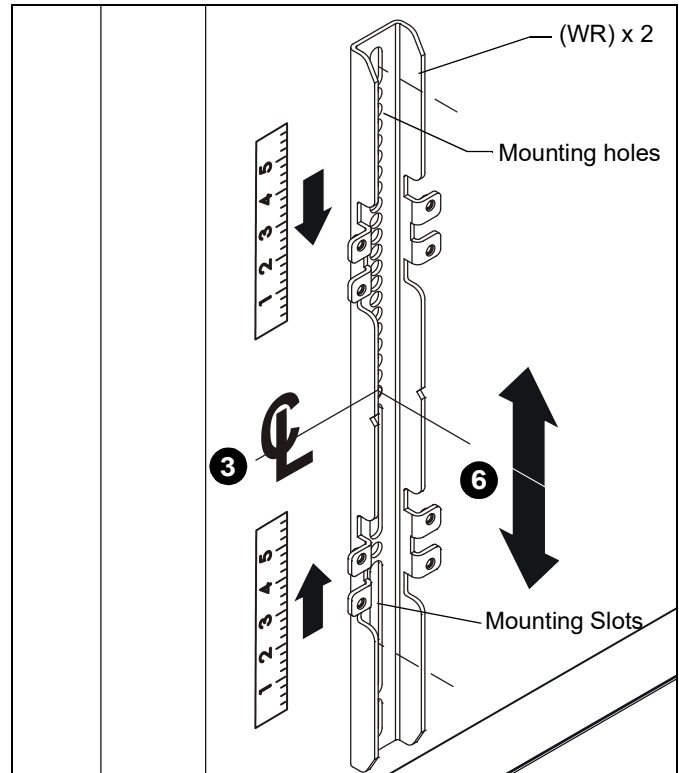

Figure 28

- Orient vertical mounting bracket (WR) so that mounting holes are on top and mounting slots are on bottom. (See Figure 28)
- Align mounting holes in vertical mounting bracket (WR) with upper and lower mounting holes in display.
- Adjust vertical mounting bracket (WR) position until mark made in Step 1 aligns with center mark in vertical mounting bracket (WR).
- Select correct screws, nesting spacers (if necessary) and universal washers (if required) from the hardware bag (WAWM) and attach brackets to back of screen. (See Figure 30)

IMPORTANT ! : The M8 screws do NOT require a washer. Use the universal washer (WMB) only with M4, M5 and M6 screws.

NOTE: The nesting spacers (WMA) may be used separately, or put two together in different configurations to create different size spacers. (See Figure 29)

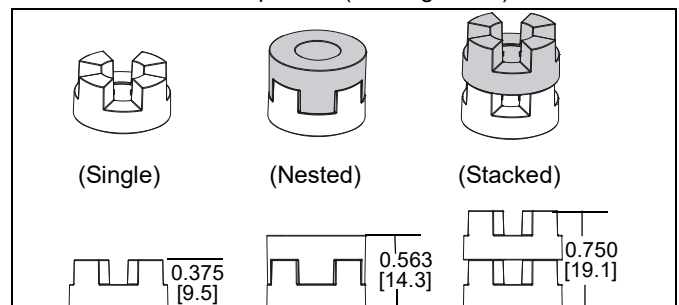

Figure 29

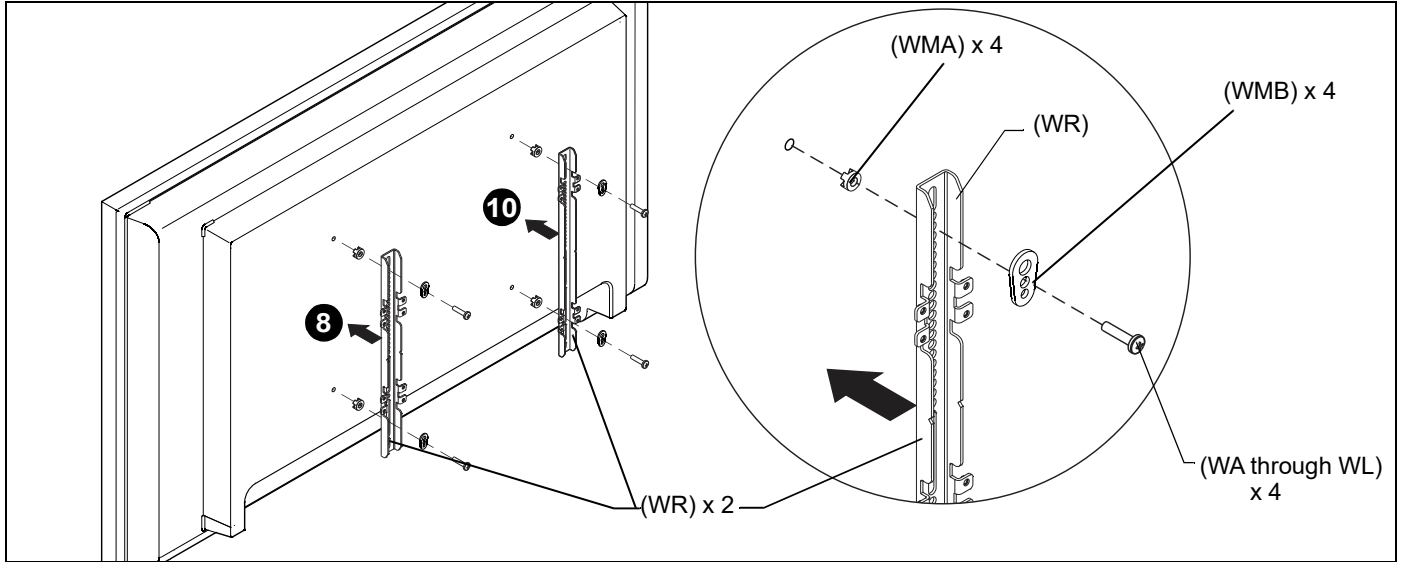

Figure 30

9. If the display has a recessed mounting surface, protrusions or a power box, a spacer and longer mounting hardware must be placed between the display and vertical mounting bracket (WR). (See Figure 30)
10. Repeat Steps 5 through 8 for Right side vertical mounting bracket using the same hole locations to align brackets horizontally.
11. Determine and mark the horizontal center position between the Left and Right *TOP* mounting holes in display. (See Figure 31)
12. Determine and mark the horizontal center position between the Left and Right *BOTTOM* mounting holes in display. (See Figure 31)
13. Orient upper horizontal mounting bracket (WQ) so that flanges are facing towards display and resting in recessed area of left and right vertical mounting brackets (WR). (See Figure 31)
14. Adjust Upper horizontal mounting bracket (WQ) position until center diamond in horizontal mounting bracket (WU) aligns with mark made in Step 11, and mounting holes and slots in horizontal mounting bracket (WQ) are aligned with threaded holes in mounting tabs of left and right vertical mounting brackets (WR). (See Figure 31) and (See Figure 32)
15. Use 1/8" hex key (WP) to secure upper horizontal mounting bracket (WQ) to left and right vertical mounting brackets (WR) using four button head flanged screws (WN). (See Figure 32)
16. Repeat Steps 12 through 15 for lower horizontal mounting bracket (WQ).

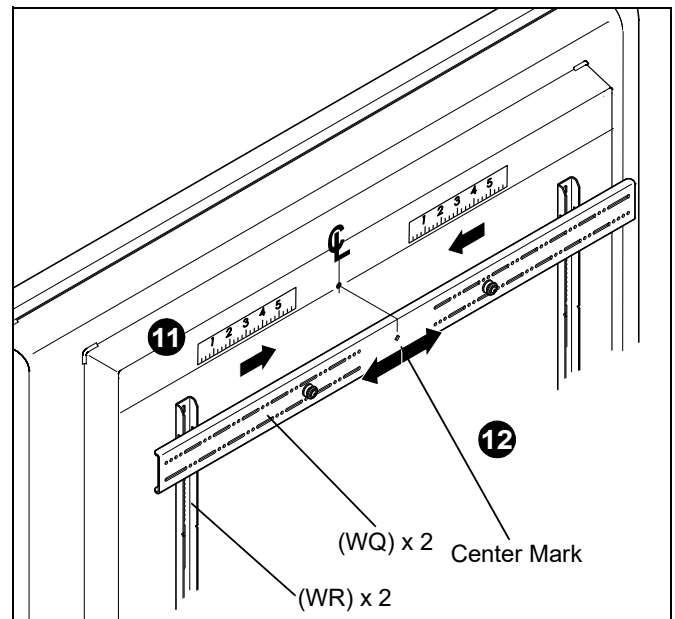

Figure 31

IMPORTANT ! : The orientation of, and mounting holes used, when installing the lower horizontal mounting bracket must be the same as the upper horizontal mounting bracket. Vertically align upper and lower brackets by aligning holes or end of slots. (See Figure 32)

IMPORTANT ! : Whenever possible install mounting screws diagonally as shown in detail in Figure 32.

17. Install display with attached universal interface to mount following the installation instructions provided with the mount.

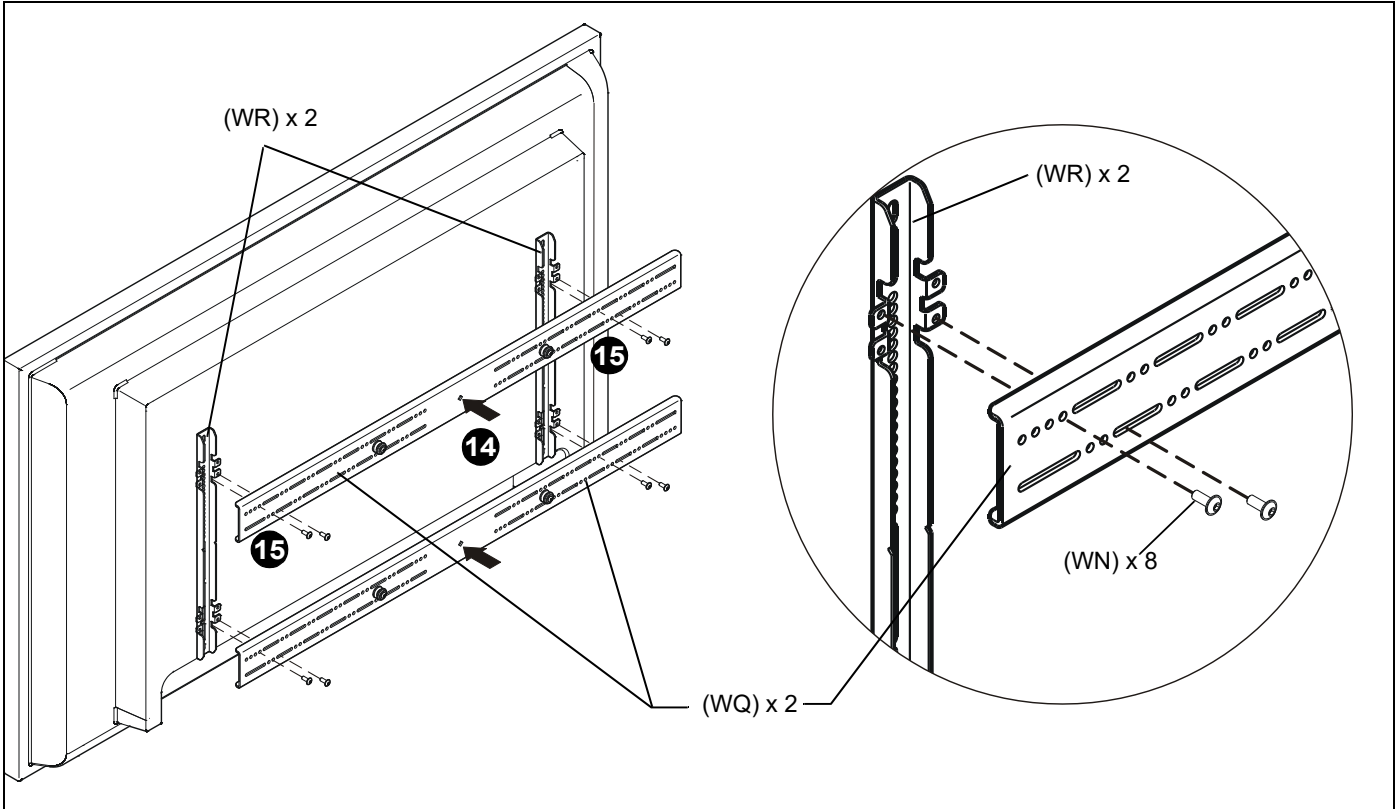

Figure 32

18. Make sure latching flags are in "closed" position prior to using cart!

IMPORTANT ! : Manufacturer recommends using cable ties (K) to secure the latching flags in closed position on both sides if padlock is not being used. (See Figure 33)

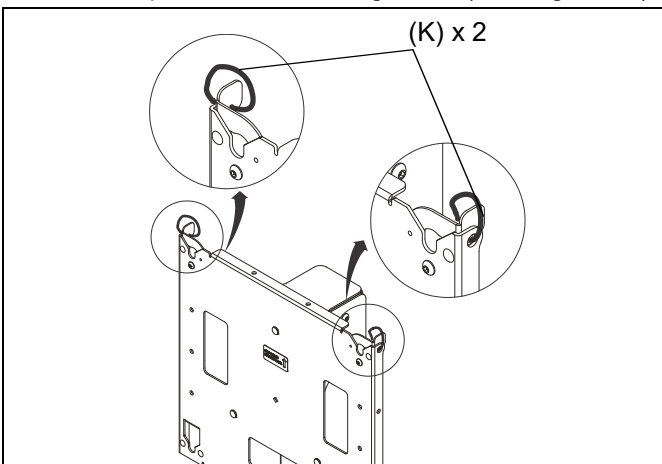

Figure 33

Adjustments

Height Adjustment

1. Press "UP" or "DOWN" buttons to raise or lower height as desired. (See Figure 34)

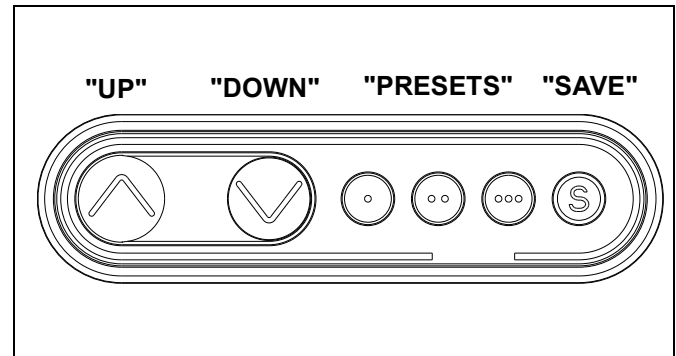

Figure 34

Save Height Levels

1. Adjust height until desired preset level is reached using "UP" and "DOWN" buttons. (See Figure 34)
2. Press "SAVE" button. (See Figure 34)
3. Press one of three preset buttons (., .. or ...) to save preset position. (See Figure 34)
4. Repeat Steps 1-3 as desired.

Tilt Adjustment

IMPORTANT ! : Remove display from mount prior to adjusting tilt!

5. Use 3/16" hex key (H) to remove tilt adjustment screws on both sides. (See Figure 35)
6. Adjust faceplate tilt and re-install removed screw in either the middle hole for 2° tilt or the lowest hole for 4° tilt. (See Figure 35)

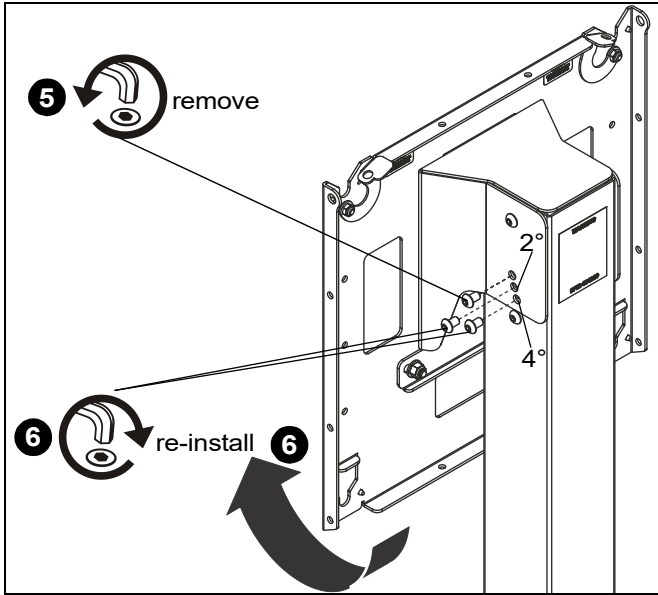

Figure 35

Roll Adjustment

7. Loosen nuts on back of faceplate. (See Figure 36)
8. Adjust roll as desired. (See Figure 36)
9. Tighten nuts on back of faceplate. (See Figure 36)

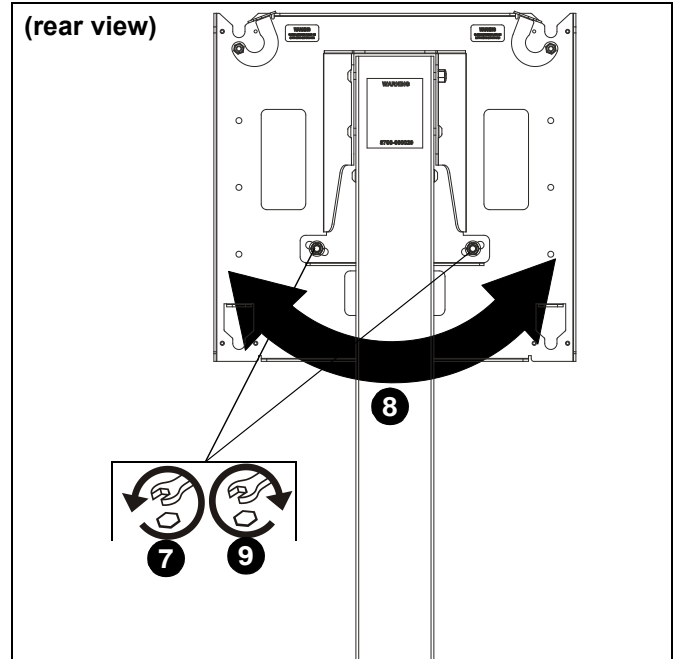

Figure 36

Troubleshooting

If lifting function does not work properly, try to following troubleshooting steps. If none of these work, contact customer service.

1. If there is uneven movement, initialize the control box (reset)
 - Hold "Down" button until lift has reached it's lower limit.
 - Briefly release "Down" button
 - Press and hold "Down" for five seconds, wait until all movement has stopped, then release
2. If there is no movement, check the following
 - Check all cable connectors between controllers and actuators.
 - Check power cable connection to control box.
3. If there is slight movement and then reverse travel, check for any obstructions that may be interfering such as cables or peripheral devices.
4. Contact customer service if none of the above steps fix the problem.

CHIEF®

A brand of  **legrand**

8800-003128 Rev03
©2026 Legrand | AV
www.legrandav.com
03/2026

USA/International	A 6436 City West Parkway, Eden Prairie, MN 55344 P 800.582.6480 / 952.225.6000 F 877.894.6918 / 952.894.6918
Europe	A Franklinstraat 14, 6003 DK Weert, Netherlands P +31 (0) 495 580 852 F +31 (0) 495 580 845
Asia Pacific	A Office No. 918 on 9/F, Shatin Galleria 18-24 Shan Mei Street Fotan, Shatin, Hong Kong P 852 2145 4099 F 852 2145 4477

