



**Hewlett Packard
Enterprise**

HPE ProLiant ML30 Gen10 Server User Guide

Abstract

This document is for the person who installs, administers, and troubleshoots servers and storage systems. Hewlett Packard Enterprise assumes you are qualified in the servicing of computer equipment and trained in recognizing hazards in products with hazardous energy levels.

Part Number: P03665-002
Published: November 2019
Edition: 2

Notices

The information contained herein is subject to change without notice. The only warranties for Hewlett Packard Enterprise products and services are set forth in the express warranty statements accompanying such products and services. Nothing herein should be construed as constituting an additional warranty. Hewlett Packard Enterprise shall not be liable for technical or editorial errors or omissions contained herein.

Confidential computer software. Valid license from Hewlett Packard Enterprise required for possession, use, or copying. Consistent with FAR 12.211 and 12.212, Commercial Computer Software, Computer Software Documentation, and Technical Data for Commercial Items are licensed to the U.S. Government under vendor's standard commercial license.

Links to third-party websites take you outside the Hewlett Packard Enterprise website. Hewlett Packard Enterprise has no control over and is not responsible for information outside the Hewlett Packard Enterprise website.

Acknowledgments

Linux® is the registered trademark of Linus Torvalds in the U.S. and other countries.

Microsoft®, Windows®, and Windows Server® are either registered trademarks or trademarks of Microsoft Corporation in the United States and/or other countries.

Red Hat® Enterprise Linux® are registered trademarks of Red Hat, Inc. in the United States and other countries.

VMware® ESXi™ and VMware vSphere® are registered trademarks or trademarks of VMware, Inc. in the United States and/or other jurisdictions.

Contents

Component identification.....	7
Front panel components.....	7
Front panel LEDs and button.....	8
Front panel LED power fault codes.....	8
Rear panel components.....	9
Rear panel LEDs.....	10
System board components.....	11
System maintenance switch descriptions.....	12
DIMM label identification.....	13
DIMM slot locations.....	14
PCI expansion slot definitions.....	15
Drive LEDs and buttons.....	16
Low profile LFF drive LED definitions.....	16
Hot-plug drive LED definitions.....	17
Drive bay numbering.....	18
Fan locations.....	20
Fan mode behavior.....	20
Media device screws.....	20
Operations.....	22
Power up the server.....	22
Power down the server.....	22
Extend the server from the rack.....	22
Remove the server from the rack.....	23
Slide the server into the rack.....	24
Remove the front bezel.....	25
Install the front bezel.....	26
Remove the access panel.....	26
Install the access panel.....	27
Remove the air baffle.....	28
Install the air baffle.....	29
Remove the PCI slot blank retainer.....	30
Remove the PCI slot blank.....	31
Position the tower server for hardware configuration.....	32
Position the tower server for operation.....	32
Setup.....	33
Optional service.....	33
Initial server installation.....	33
HPE Installation Service.....	33
Setting up the server.....	34
Operational requirements.....	37
Space and airflow requirements.....	37
Temperature requirements.....	38
Power requirements.....	38
Electrical grounding requirements.....	38

Server warnings and cautions.....	38
Rack warnings and cautions.....	39
Preventing electrostatic discharge.....	40
POST screen options.....	40
Installing or deploying an operating system.....	41

Hardware options installation..... 42

Product QuickSpecs.....	42
Introduction.....	42
Tower to rack conversion kit.....	42
Installing the tower-to-rack conversion kit.....	42
Preparing the server for rack installation.....	42
Installing the rack rails and server tray.....	43
Installing the server on the tray.....	46
Installing the PCI fan and air baffle options.....	47
Drive options.....	49
Drive installation guidelines.....	49
Drive support information.....	50
Installing an LFF non-hot-plug drive in the drive cage.....	50
Installing an LFF hot-plug drive.....	52
Installing an SFF hot-plug drive.....	53
Power supply options.....	54
Hot-plug power supply calculations.....	54
Power supply warnings and cautions.....	55
Flexible Slot (Redundant) power supply enablement option.....	55
Installing a Flexible Slot (Redundant) power supply enablement option.....	55
Media device options.....	58
Installing a SAS LTO tape drive.....	59
Installing a USB RDX drive.....	61
Installing an optical drive.....	63
Installing an LFF non-hot-plug drive in the media drive bay.....	66
Memory options.....	68
DIMM population information.....	68
Installing a DIMM.....	68
M.2 SSD/dedicated iLO/serial port enablement option.....	69
M.2 SSD/dedicated iLO/serial port enablement option components.....	70
Installing the M.2 SSD/dedicated iLO/serial port enablement board.....	70
Installing the serial port cable.....	73
Enabling the dedicated iLO management module.....	76
M.2 SSD option.....	77
Installing an M.2 NVMe SSD on the system board.....	77
Installing an M.2 NVMe SSD on an M.2 SSD/dedicated iLO/serial port enablement board.....	79
Storage controller options.....	81
Installing a Smart Array standup storage controller.....	82
Configuring an HPE Smart Array Gen10 controller.....	84
Energy pack options.....	84
HPE Smart Storage Battery.....	85
HPE Smart Storage Hybrid Capacitor.....	85
Minimum firmware versions.....	85
Installing an energy pack.....	85
Expansion board options.....	88
Expansion board thermal requirement.....	88
Installing an expansion board.....	88
Internal USB device option.....	90

Installing an internal USB device.....	91
HPE Trusted Platform Module 2.0 Gen10 option.....	92
Overview.....	92
HPE Trusted Platform Module 2.0 Guidelines.....	92
Installing and enabling the HPE TPM 2.0 Gen10 Kit.....	93
Installing the Trusted Platform Module board.....	93
Enabling the Trusted Platform Module.....	96
Retaining the BitLocker recovery key/password.....	97

Cabling..... 98

Cabling guidelines.....	98
Storage cabling.....	99
LFF non-hot-plug drive cabling from the media bay.....	99
LFF non-hot-plug drive cabling from the drive cage.....	100
LFF hot-plug drive cabling.....	102
SFF hot-plug drive cabling.....	104
Energy pack cabling.....	106
Controller backup power cabling.....	106
Media device cabling.....	107
SATA optical drive cabling.....	107
SAS LTO tape drive cabling.....	107
USB RDX drive cabling.....	109
Serial port cabling.....	110
Fan cabling.....	110
Power supply cabling.....	112
Front I/O cabling.....	113
Front USB cabling.....	113

Software and configuration utilities..... 114

Server mode.....	114
Product QuickSpecs.....	114
Active Health System Viewer.....	114
Active Health System.....	114
Active Health System data collection.....	115
Active Health System Log.....	115
HPE iLO 5.....	115
iLO Federation.....	116
iLO Service Port.....	116
iLO RESTful API.....	117
RESTful Interface Tool.....	117
iLO Amplifier Pack.....	117
Integrated Management Log.....	117
Intelligent Provisioning.....	118
Intelligent Provisioning operation.....	118
Management Security.....	119
Scripting Toolkit for Windows and Linux.....	119
UEFI System Utilities.....	119
Selecting the boot mode	120
Secure Boot.....	120
Launching the Embedded UEFI Shell	121
HPE Smart Storage Administrator.....	122
HPE InfoSight for servers	122
USB support.....	122

External USB functionality.....	122
Redundant ROM support.....	123
Safety and security benefits.....	123
Keeping the system current.....	123
Updating firmware or system ROM.....	123
Service Pack for ProLiant.....	123
Updating firmware from the System Utilities	124
Updating the firmware from the UEFI Embedded Shell	125
Online Flash components.....	125
Drivers.....	125
Software and firmware.....	126
Operating system version support.....	126
HPE Pointnext Portfolio.....	126
Proactive notifications.....	126
Troubleshooting.....	127
NMI functionality.....	127
Troubleshooting resources.....	127
System battery replacement.....	128
System battery information.....	128
Removing and replacing the system battery.....	128
Safety, warranty, and regulatory information.....	131
Regulatory information.....	131
Notices for Eurasian Economic Union.....	131
Turkey RoHS material content declaration.....	132
Ukraine RoHS material content declaration.....	132
GS Gloss declaration.....	132
Specifications.....	133
Environmental specifications.....	133
Server specifications.....	133
Power supply specifications.....	133
HPE 350W E-star 1.0 Non-hot-plug Power Supply.....	134
HPE 500W Flex Slot Platinum Hot-plug Low Halogen Power Supply.....	134
Websites.....	136
Support and other resources.....	137
Accessing Hewlett Packard Enterprise Support.....	137
ClearCARE technical support.....	137
Accessing updates.....	137
Customer self repair.....	138
Remote support.....	138
Documentation feedback.....	139
Acronyms and abbreviations.....	140

Component identification

Front panel components

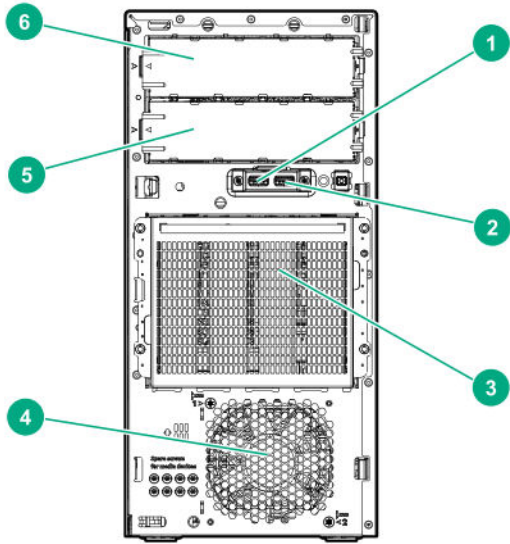

Item	Description
1	USB 3.0 port
2	USB 2.0 port
3	Drive cage bay
4	PCI fan (optional)
5	Media bay 2
6	Media bay 1

Front panel LEDs and button

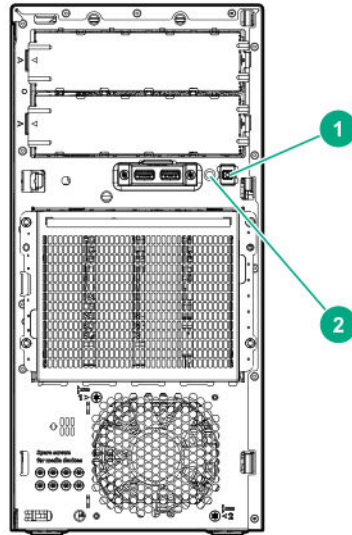

Item	Description	Status	Definition
1	Power On/Standby button and system power LED ¹	Solid green	System on
		Flashing green	Performing power-on sequence
		Solid amber	System in standby
		Off	No power present
2	Health LED ¹	Solid green	Normal
		Flashing green	iLO rebooting
		Flashing amber	System degraded
		Flashing red	System critical

¹ When the LEDs described in this table flash simultaneously, a power fault has occurred. For more information, see **Front panel LED power fault codes**.

Front panel LED power fault codes

The following table provides a list of power fault codes, and the subsystems that are affected. Not all power faults are used by all servers.

Subsystem	LED behavior
System board	1 flash
Processor	2 flashes
Memory	3 flashes
Riser board PCIe slots	4 flashes
FlexibleLOM	5 flashes

Table Continued

Subsystem	LED behavior
Removable HPE Smart Array SR Gen10 controller	6 flashes
System board PCIe slots	7 flashes
Power backplane or storage backplane	8 flashes
Power supply	9 flashes

Rear panel components

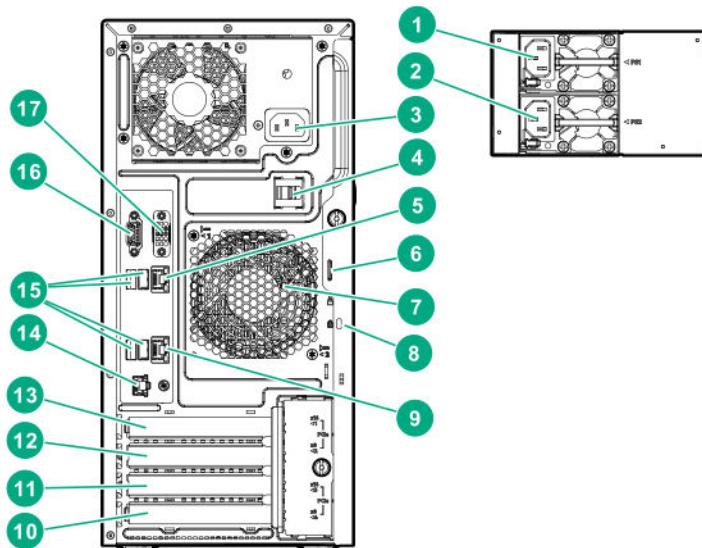

Item	Description
1	Flexible Slot power supply 1 (hot-plug)
2	Flexible Slot power supply 2 (hot-plug)
3	Standard power supply (non-hot-plug)
4	Power cord strain relief clip
5	NIC 1/iLO Shared Network Port
6	Padlock eye
7	System fan
8	Kensington security slot
9	NIC port 2
10	Slot 4 PCI3 x8 (4, 1), half-length ¹
11	Slot 3 PCI3 x16 (4,1), full-length ¹
12	Slot 2 PCI3 x 8 (4,1), half-length ¹
13	Slot 1 PCI3 x16 (16, 8, 4, 1), full-length ¹
14	iLO Dedicated Network Port (optional)

Table Continued

Item	Description
15	USB 3.0 ports
16	VGA port
17	Serial port (optional)

¹ For more information on the expansion slot specifications, see [PCI expansion slot definitions](#).

Rear panel LEDs

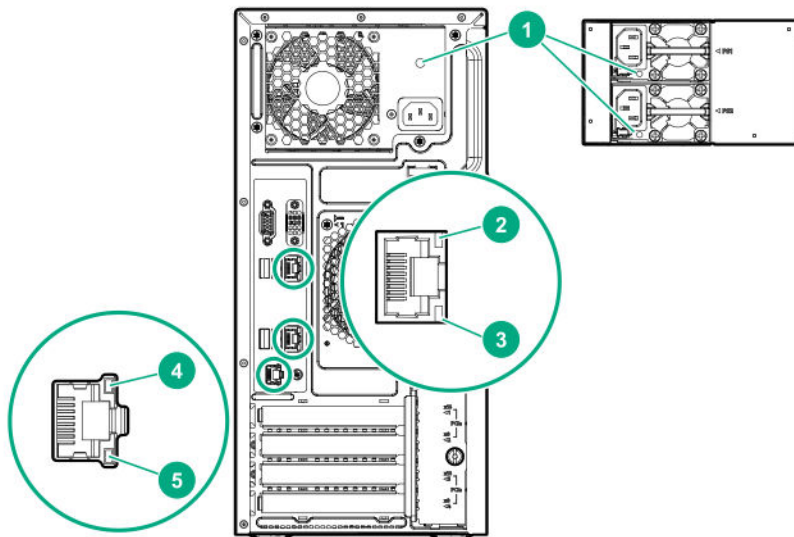

Item	Description	Status	Definition
1	Power supply	Solid green	Normal
		Off	System is off or power supply has failed.
2	NIC link	Green	Network link
		Off	No network link
3	NIC status	Green or flashing green	Network active
		Off	No network activity
4	iLO link	Green	Network link
		Off	No network link
5	iLO status	Green or flashing green	Network active
		Off	No network activity

System board components

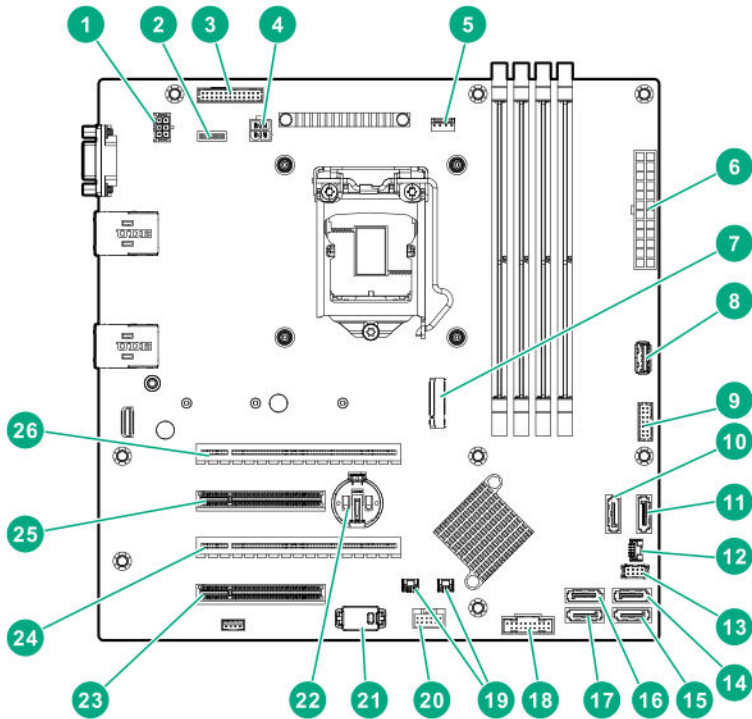

Item	Description
1	System fan connector
2	System maintenance switch
3	Flexible Slot power supply connector
4	4-pin power connector
5	Heatsink fan connector
6	24-pin power connector
7	M.2 SSD slot
8	Internal USB 3.0 connector
9	Front I/O connector
10	x1 SATA port 1
11	x1 SATA port 2
12	Drive backplane sideband connector
13	PCI fan connector
14	x1 SATA port 3
15	x1 SATA port 4
16	x1 SATA port 5

Table Continued

Item	Description
17	x1 SATA port 6
18	Front USB connector
19	Controller backup power connectors
20	Energy pack connector
21	TPM connector
22	System battery
23	Slot 4 PCI3 x8 (4, 1), half-length ¹
24	Slot 3 PCI3 x16 (4, 1), full-length ¹
25	Slot 2 PCI3 x8 (4, 1), half-length ¹
26	Slot 1 PCI3 x16 (16, 8, 4, 1), full-length ¹

¹ For more information on the expansion slot specifications, see [PCI expansion slot definitions](#).

System maintenance switch descriptions

Position	Default	Function
S1 ¹	Off	Off = iLO 5 security is enabled. On = iLO 5 security is disabled.
S2	Off	Reserved
S3	Off	Reserved
S4	Off	Reserved
S5 ¹	Off	Off = Power-on password is enabled. On = Power-on password is disabled.
S6 ^{1, 2, 3}	Off	Off = No function On = Restore default manufacturing settings
S7	Off	Reserved
S8	—	Reserved
S9	—	Reserved
S10	—	Reserved
S11	—	Reserved
S12	—	Reserved

¹ To access the redundant ROM, set S1, S5, and S6 to On.

² When the system maintenance switch position 6 is set to the On position, the system is prepared to restore all configuration settings to their manufacturing defaults.

- ³ When the system maintenance switch position 6 is set to the On position and Secure Boot is enabled, some configurations cannot be restored. For more information, see **Secure Boot**.

DIMM label identification

To determine DIMM characteristics, see the label attached to the DIMM. The information in this section helps you to use the label to locate specific information about the DIMM.

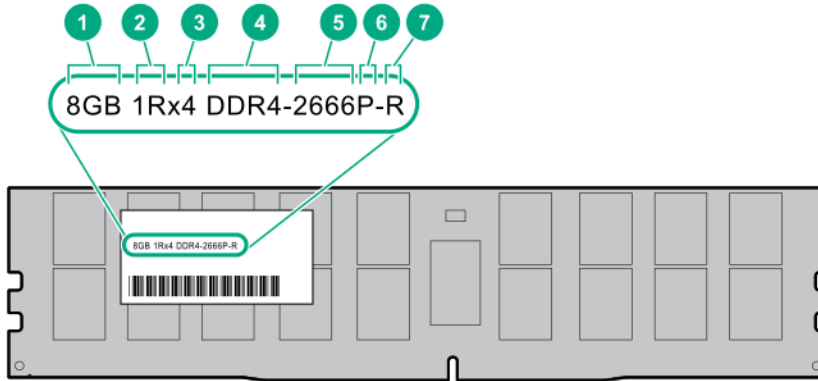

Item	Description	Example
1	Capacity	8 GB 16 GB 32 GB 64 GB 128 GB
2	Rank	1R = Single rank 2R = Dual rank 4R = Quad rank 8R = Octal rank
3	Data width on DRAM	x4 = 4-bit x8 = 8-bit x16 = 16-bit
4	Memory generation	PC4 = DDR4

Table Continued

Item	Description	Example
5	Maximum memory speed	2133 MT/s 2400 MT/s 2666 MT/s 2933 MT/s
6	CAS latency	P = CAS 15-15-15 T = CAS 17-17-17 U = CAS 20-18-18 V = CAS 19-19-19 (for RDIMM, LRDIMM) V = CAS 22-19-19 (for 3DS TSV LRDIMM) Y = CAS 21-21-21 (for RDIMM, LRDIMM) Y = CAS 24-21-21 (for 3DS TSV LRDIMM)
7	DIMM type	R = RDIMM (registered) L = LRDIMM (load reduced) E = Unbuffered ECC (UDIMM)

For more information about product features, specifications, options, configurations, and compatibility, see the HPE DDR4 SmartMemory QuickSpecs on the Hewlett Packard Enterprise website (<http://www.hpe.com/support/DDR4SmartMemoryQS>).

DIMM slot locations

DIMM slots are numbered sequentially (1 through 4). The supported AMP modes use the letter assignments for population guidelines.

The arrow in the illustration points to the front of the server.

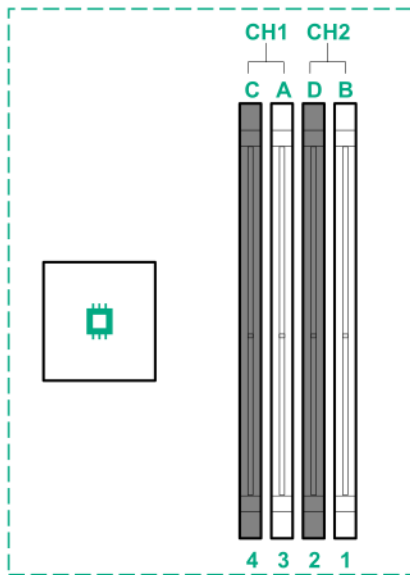

PCI expansion slot definitions

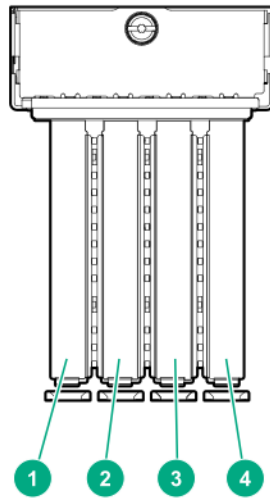

Slot	Type	Form factor	Connector link width	Negotiable link width	Supported expansion boards
1	PCI3	FLFH ¹	x16	16, 8, 4, 1	<ul style="list-style-type: none"> • Single-width GPU • 10 GB Ethernet adapter • Type-p Smart Array controller • FC HBA
2	PCI3	HLFH ²	x8	4, 1	<ul style="list-style-type: none"> • 1 GB Ethernet adapter • 10 GB Ethernet adapter

Table Continued

Slot	Type	Form factor	Connector link width	Negotiable link width	Supported expansion boards
3	PCI3	FLFH ¹	x16	4, 1	<ul style="list-style-type: none"> • 10 GB Ethernet adapter • Type-p Smart Array controller • FC HBA
4	PCI3	HLFH ²	x8	4, 1	<ul style="list-style-type: none"> • 1 GB Ethernet adapter • 10 GB Ethernet adapter

¹ FLFH=Full length, full height

² HLFH=Half length, full height

Drive LEDs and buttons

Low profile LFF drive LED definitions

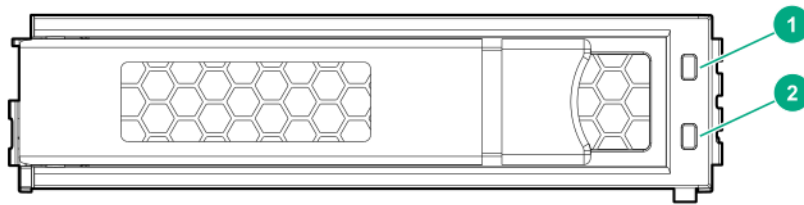

Item	LED	Status	Definition
1	Fault \Locate	Solid amber	The drive has failed.
		Solid blue	The drive is operating normally and being identified by a management application.
		Flashing amber/blue (1 flash per second)	The drive has failed, or a predictive failure alert has been received for this drive; it also has been identified by a management application.
		Flashing amber (1 flash per second)	A predictive failure alert has been received for this drive. Replace the drive as soon as possible.
2	Online \Activity	Solid green	The drive is online and has no activity.
		Flashing green (4 flashes per second)	The drive is operating normally and has activity.

Table Continued

Item	LED	Status	Definition
		Flashing green (1 flash per second)	The drive is doing one of the following: <ul style="list-style-type: none"> • Rebuilding • Performing a RAID migration • Performing a strip size migration • Performing a capacity expansion • Performing a logical drive extension • Erasing • Spare part activation
		Off	The drive is not configured by a RAID controller or a spare drive.

Hot-plug drive LED definitions

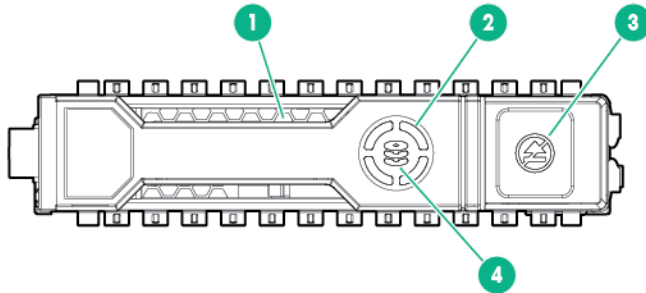

Item	LED	Status	Definition
1	Locate	Solid blue	The drive is being identified by a host application.
		Flashing blue	The drive carrier firmware is being updated or requires an update.
2	Activity ring	Rotating green	Drive activity
		Off	No drive activity
3	Do not remove	Solid white	Do not remove the drive. Removing the drive causes one or more of the logical drives to fail.
		Off	Removing the drive does not cause a logical drive to fail.
4	Drive status	Solid green	The drive is a member of one or more logical drives.

Table Continued

Item	LED	Status	Definition
		Flashing green	The drive is doing one of the following: <ul style="list-style-type: none"> • Rebuilding • Performing a RAID migration • Performing a strip size migration • Performing a capacity expansion • Performing a logical drive extension • Erasing • Spare part activation
		Flashing amber/ green	The drive is a member of one or more logical drives and predicts the drive will fail.
		Flashing amber	The drive is not configured and predicts the drive will fail.
		Solid amber	The drive has failed.
		Off	The drive is not configured by a RAID controller or a spare drive.

Drive bay numbering

Four-bay LFF non-hot-plug drive numbering

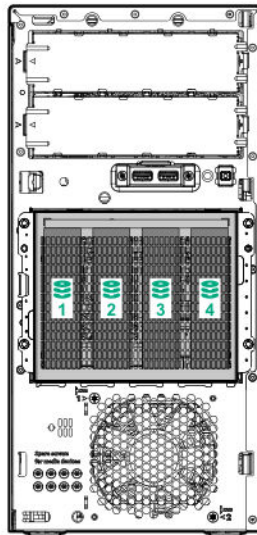

Four-bay LFF hot-plug drive numbering

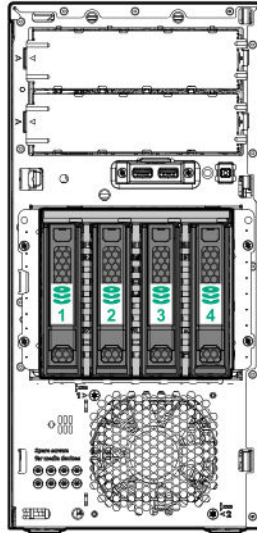

Eight-bay SFF hot-plug drive numbering

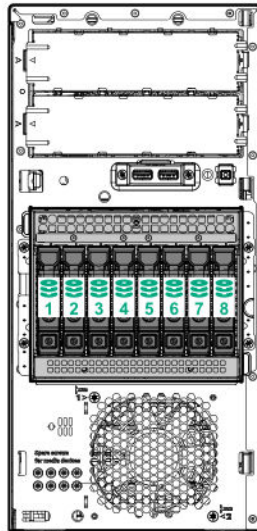

Fan locations

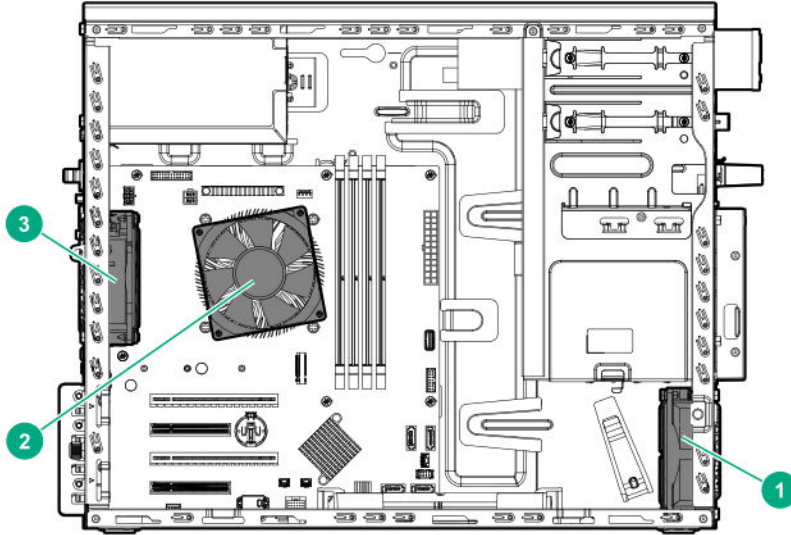

Fan number	Fan type
1	PCI fan (optional)
2	Heatsink fan
3	System fan

Fan mode behavior

The server supports only nonredundant fan mode. If a single fan fails or is missing, the following behaviors are exhibited:

- The health LED flashes amber.
- The operating system performs a graceful shutdown.

Media device screws

There are eight T-15 Torx screws on the front panel. These screws are provided as spare screws for installing media devices.

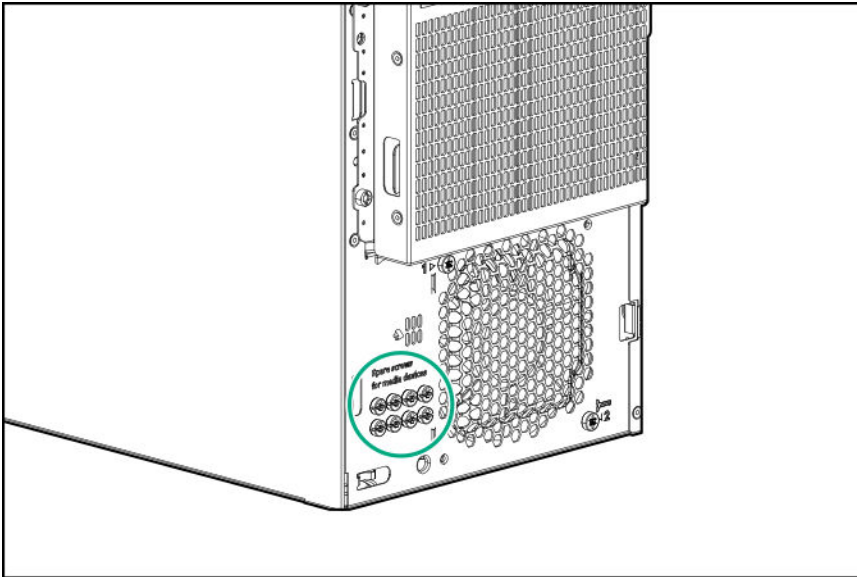

Operations

Power up the server

To power up the server, use one of the following methods:

- Press the Power On/Standby button.
- Use the virtual power button through iLO.

Power down the server

Before powering down the server for any upgrade or maintenance procedures, perform a backup of critical server data and programs.

 **IMPORTANT:** When the server is in standby mode, auxiliary power is still being provided to the system.

To power down the server, use one of the following methods:

- Press and release the Power On/Standby button.
This method initiates a controlled shutdown of applications and the OS before the server enters standby mode.
- Press and hold the Power On/Standby button for more than 4 seconds to force the server to enter standby mode.
This method forces the server to enter standby mode without properly exiting applications and the OS. If an application stops responding, you can use this method to force a shutdown.
- Use a virtual power button selection through iLO 5.
This method initiates a controlled remote shutdown of applications and the OS before the server enters standby mode.

Before proceeding, verify that the server is in standby mode by observing that the system power LED is amber.

Extend the server from the rack

Procedure

- 1. Power down the server.**
2. Remove all power:
 - a. Disconnect each power cord from the power source.
 - b. Disconnect each power cord from the server.
3. Disconnect all peripheral cables from the server.

 **WARNING:** To reduce the risk of personal injury or equipment damage, be sure that the rack is adequately stabilized before extending a component from the rack.

4. Slide the server tray out of the rack:

- a. Loosen the server tray thumbscrews.
- b. Grasp the tray notch and slide the server out of the rack.

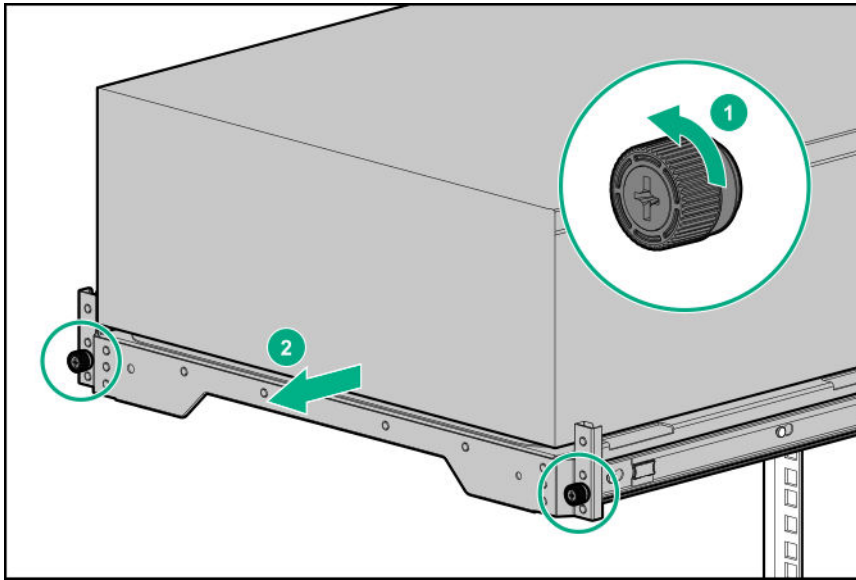

Remove the server from the rack



WARNING: This server is heavy. To reduce the risk of personal injury or damage to the equipment:

- Observe local occupational health and safety requirements and guidelines for manual material handling.
- Get help to lift and stabilize the product during installation or removal, especially when the product is not fastened to the rails. Hewlett Packard Enterprise recommends that a minimum of two people are required for all rack server installations. A third person may be required to help align the server if the server is installed higher than chest level.
- Use caution when installing the server in or removing the server from the rack; it is unstable when not fastened to the rails.

Procedure

- 1. Power down the server.**
- 2. Remove all power:**
 - a. Disconnect each power cord from the power source.
 - b. Disconnect each power cord from the server.
- 3. Disconnect all peripheral cables from the server.**
- 4. If installed, unlock and remove the security padlock and/or the Kensington security lock.**

For more information, see the lock documentation.
- 5. Extend the server from the rack.**
- 6. Remove the server from the tray.**

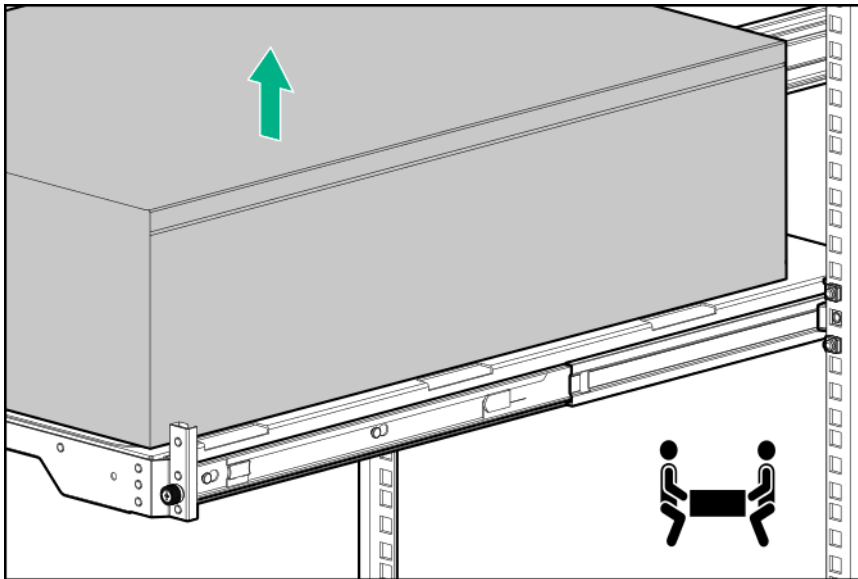

7. Place the server on a flat, level surface with the access panel facing up.

Slide the server into the rack

Procedure

1. Press and hold the blue release latches on both rails, and then slide the server tray back into the rack.

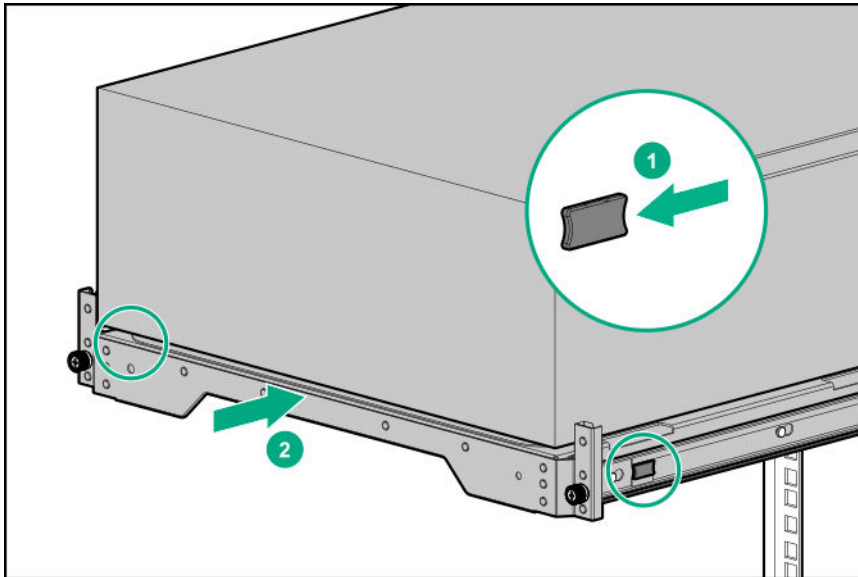

2. Tighten the server tray thumbscrews.

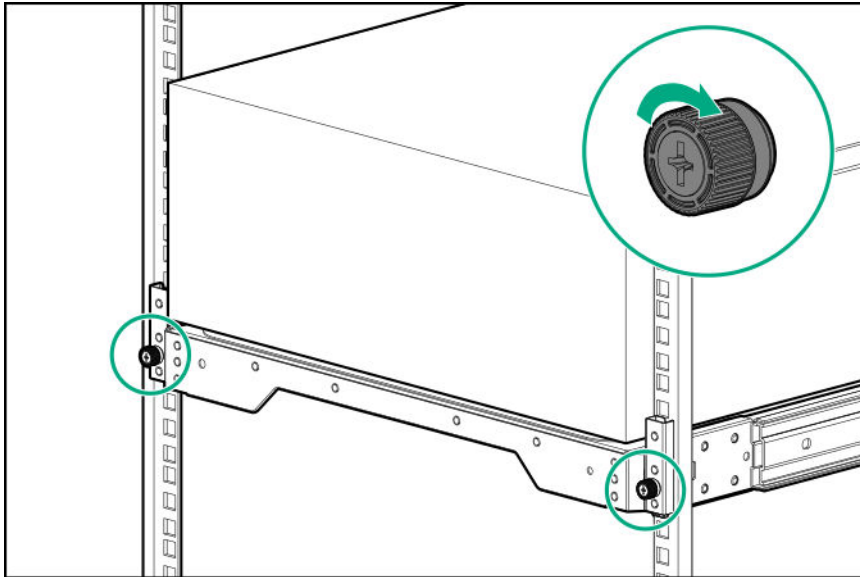

Remove the front bezel

Procedure

1. If locked, unlock the front bezel.
2. Open the front bezel.
3. Pull the front bezel away from the chassis.

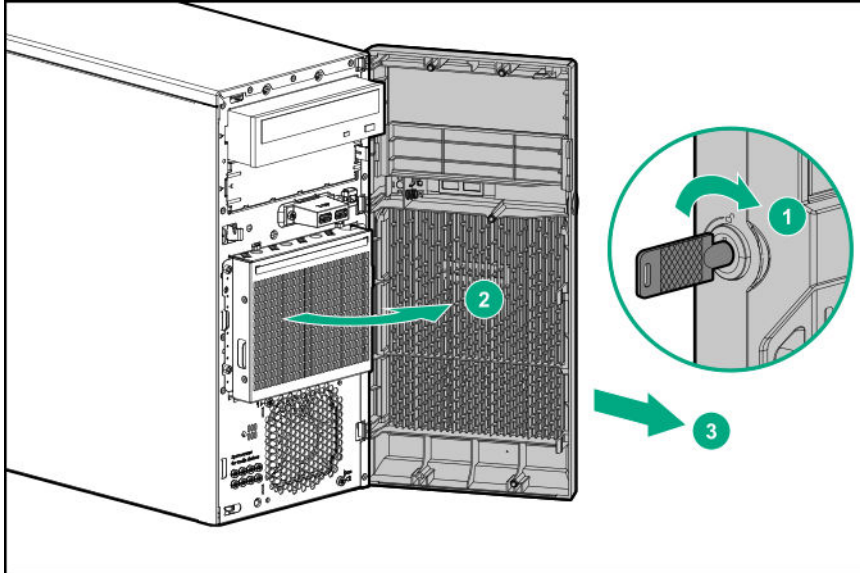

Install the front bezel

Procedure

1. Insert the tabs on the bezel into the slots on the front chassis.
2. Close the front bezel.
3. Lock the front bezel.

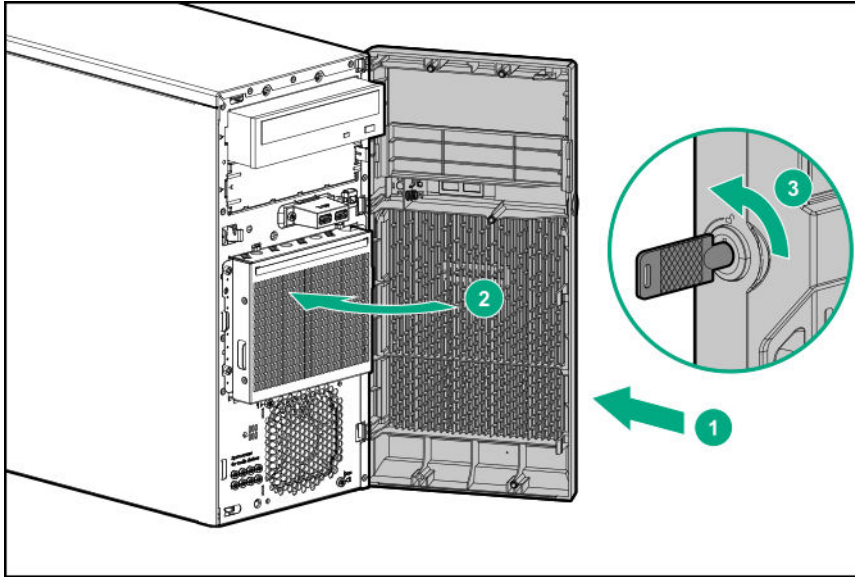

Remove the access panel

-
- ⚠ WARNING:** To reduce the risk of personal injury from hot surfaces, allow the drives and the internal system components to cool before touching them.
-
- ⚠ CAUTION:** To prevent damage to electrical components, take the appropriate anti-static precautions before beginning any installation, removal, or replacement procedure. Improper grounding can cause electrostatic discharge.
-
- ⚠ CAUTION:** Do not operate the server for long periods with the access panel open or removed. Operating the server in this manner results in improper airflow and improper cooling that can lead to thermal damage.
-

Procedure

1. **Power down the server.**
2. Remove all power:
 - a. Disconnect each power cord from the power source.
 - b. Disconnect each power cord from the server.
3. Disconnect all peripheral cables from the server.
4. If installed, unlock and remove the security padlock and/or Kensington security lock.

For more information, see the lock documentation.

5. Do one of the following:
 - If the server is in tower mode: **Position the tower server for hardware configuration.**
 - If the server is in rack mode: **Remove the server from the rack.**
6. **Remove the front bezel.**
7. Remove the access panel:
 - a. Loosen the access panel thumbscrew.
 - b. Slide the access panel, and then lift it away from the chassis.

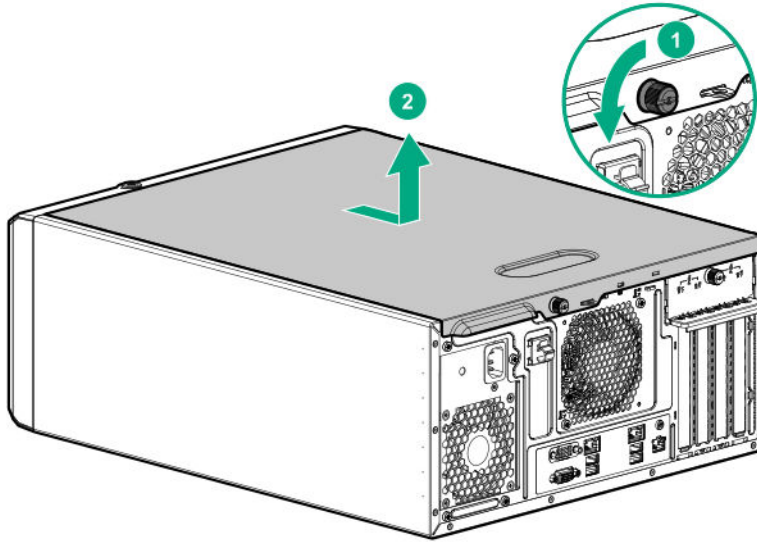

Install the access panel

Procedure

1. Install the access panel:
 - a. Place the access panel on the chassis and slide it toward the front of the server.
 - b. Tighten the access panel thumbscrew.

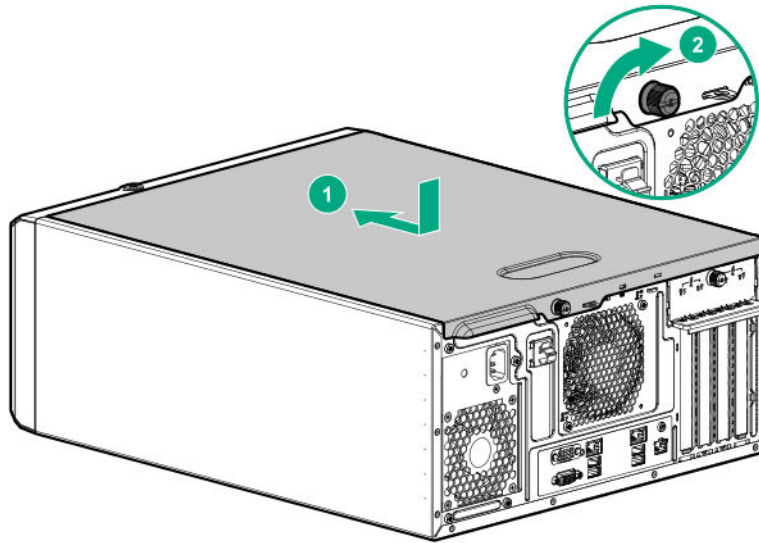

2. Install the front bezel.

3. Do one of the following:

If the server is in tower mode: **Position the tower server for operation.**

If the server is in rack mode: **Install the server on the tray.**

4. If removed, install the security padlock and/or Kensington security lock.

For more information, see the lock documentation.

5. Connect all peripheral cables to the server.

6. Connect the power cords:

- a.** Connect each power cord to the server.
- b.** Connect each power cord to the power source.

7. Power up the server.

Remove the air baffle

⚠ CAUTION: For proper cooling, do not operate the server without the access panel, baffles, expansion slot covers, or blanks installed. If the server supports hot-plug components, minimize the amount of time the access panel is open.

Procedure

1. Power down the server.

2. Remove all power:

- a.** Disconnect each power cord from the power source.
- b.** Disconnect each power cord from the server.

3. Disconnect all peripheral cables from the server.

4. Do one of the following:
 - If the server is in tower mode: **Position the tower server for hardware configuration.**
 - If the server is in rack mode: **Remove the server from the rack.**
5. **Remove the front bezel.**
6. **Remove the access panel.**
7. Remove the air baffle:
 - a. Lift the front end of the baffle from the chassis.
 - b. Remove the baffle from the slots on the rear chassis.

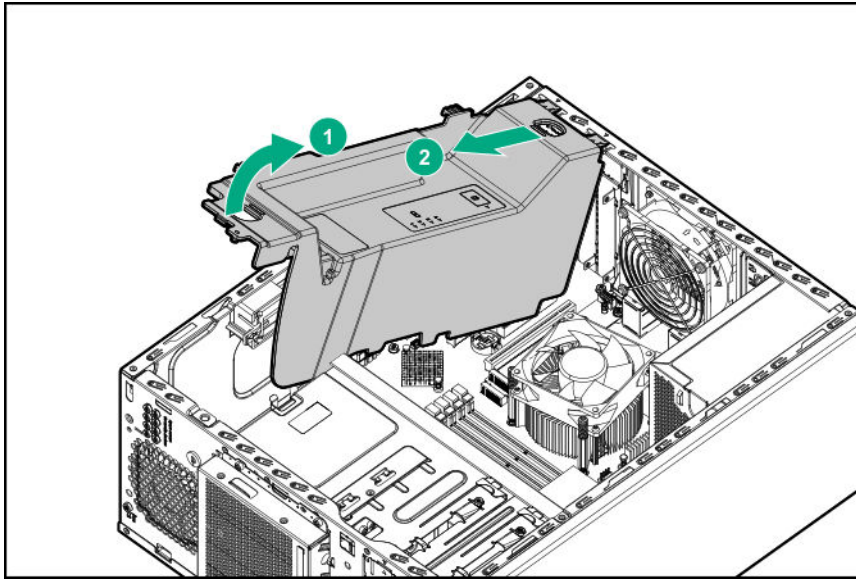

Install the air baffle

- ⚠ CAUTION:** For proper cooling, do not operate the server without the access panel, baffles, expansion slot covers, or blanks installed. If the server supports hot-plug components, minimize the amount of time the access panel is open.

Procedure

1. Install the air baffle:
 - a. Insert the tabs on the baffle into the slots on the rear chassis.
 - b. Press the front end of the baffle into the chassis.

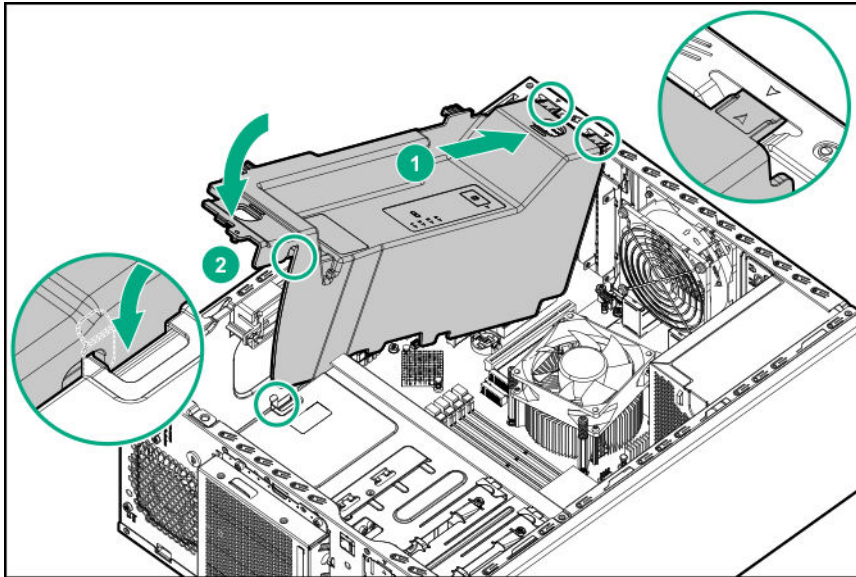

2. **Install the access panel.**
3. **Install the front bezel.**
4. Do one of the following:
 - If the server is in tower mode: **Position the tower server for operation.**
 - If the server is in rack mode: **Install the server on the tray.**
5. Connect all peripheral cables to the server.
6. Connect the power cords:
 - a. Connect each power cord to the server.
 - b. Connect each power cord to the power source.
7. **Power up the server.**

Remove the PCI slot blank retainer

Procedure

1. Remove the PCI slot blank retainer:
 - a. Loosen the retainer thumbscrew.
 - b. Slide the retainer up, then remove it from the chassis.

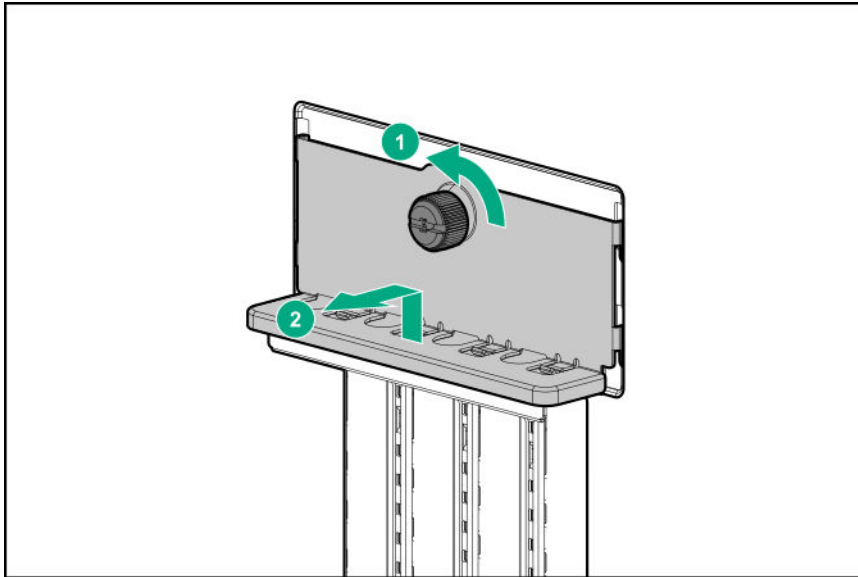

Remove the PCI slot blank

⚠ CAUTION: To prevent improper cooling and thermal damage, do not operate the server unless all PCI slots have either an expansion slot cover or an expansion board installed.

Procedure

1. Identify the expansion slot compatible with the option, see [PCI expansion slot definitions](#).
2. Pull up the blank opposite the selected expansion slot.

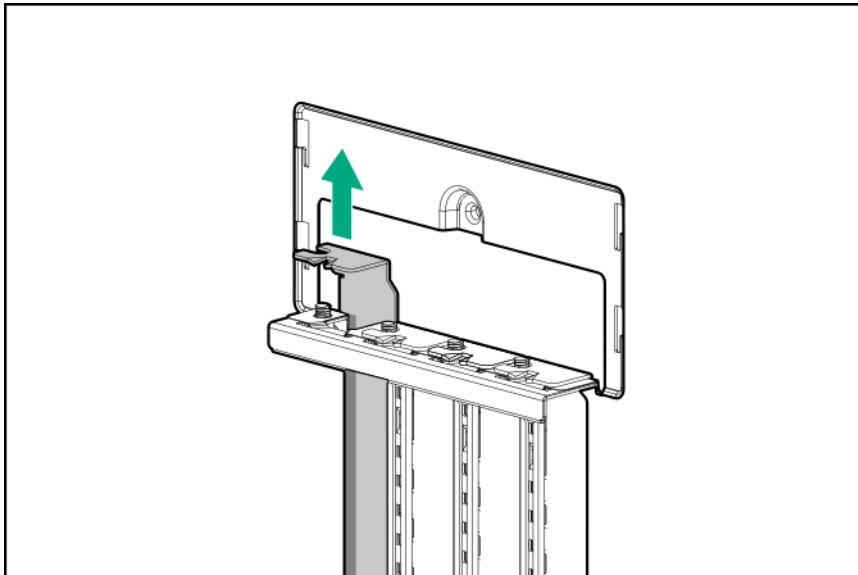

Position the tower server for hardware configuration

Procedure

Place the server on a flat, level surface with the access panel facing up.

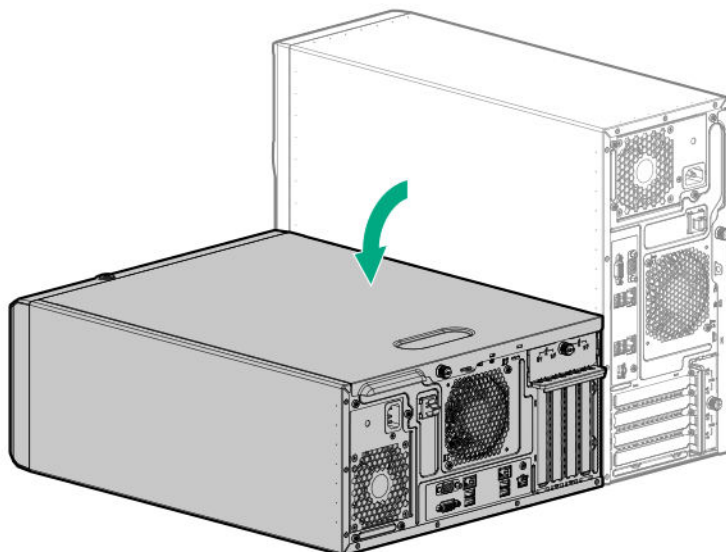

Position the tower server for operation

Procedure

Return the server to an upright position.

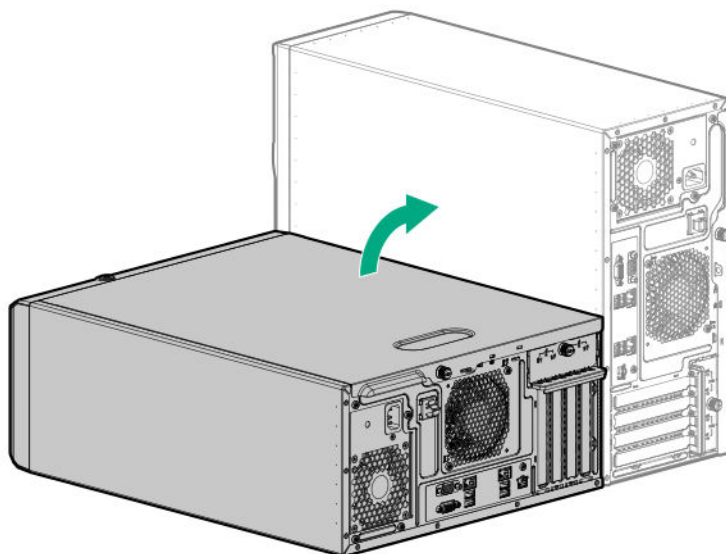

Setup

Optional service

Delivered by experienced, certified engineers, Hewlett Packard Enterprise support services help you keep your servers up and running with support packages tailored specifically for HPE ProLiant systems. Hewlett Packard Enterprise support services let you integrate both hardware and software support into a single package. A number of service level options are available to meet your business and IT needs.

Hewlett Packard Enterprise support services offer upgraded service levels to expand the standard product warranty with easy-to-buy, easy-to-use support packages that will help you make the most of your server investments. Some of the Hewlett Packard Enterprise support services for hardware, software or both are:

- Foundation Care – Keep systems running.
 - 6-Hour Call-to-Repair¹
 - 4-Hour 24x7
 - Next Business Day
- Proactive Care – Help prevent service incidents and get you to technical experts when there is one.
 - 6-Hour Call-to-Repair¹
 - 4-Hour 24x7
 - Next Business Day
- Deployment service for both hardware and software
- Hewlett Packard Enterprise Education Services – Help train your IT staff.

¹The time commitment for this repair service might vary depending on the geographical region of site. For more service information available in your site, contact your local **Hewlett Packard Enterprise support center**.

For more information on Hewlett Packard Enterprise support services, see the **Hewlett Packard Enterprise website**.

Initial server installation

Depending on the technical expertise of the user and the complexity of the product, for the initial server installation, the user can choose to:

- **Order the HPE Installation Service.**
- **Perform the initial server setup procedure.**

HPE Installation Service

HPE Installation Service provides basic installation of Hewlett Packard Enterprise branded equipment, software products, as well as HPE-supported products from other vendors that are sold by HPE or by HPE authorized resellers. The Installation Service is part of a suite of HPE deployment services that are designed to give users the peace of mind that comes from knowing that their HPE and HPE-supported products have been installed by an HPE specialist.

The HPE Installation Service provides the following benefits:

- Installation by an HPE authorized technical specialist.
- Verification prior to installation that all service prerequisites are met.
- Delivery of the service at a mutually scheduled time convenient to your organization.
- Allows your IT resources to stay focused on their core tasks and priorities.
- Full coverage during the warranty period for products that require installation by an HPE authorized technical specialist.

For more information on the features, limitations, provisions, and ordering information of the HPE Installation Service, see this Hewlett Packard Enterprise website:

<http://www.hpe.com/support/installation-service>

Setting up the server

Prerequisites

Before setting up the server:

- Download the latest SPP:

<http://www.hpe.com/servers/spp/download>

Support validation required

- Verify that your OS or virtualization software is supported:

<http://www.hpe.com/info/ossupport>

- Obtain the storage driver if needed:

- Download it from the HPE Support Center website:

<http://www.hpe.com/support/hpesc>

- Extract it from the SPP.

- Read the HPE UEFI requirements for ProLiant servers on the HPE website:

<http://www.hpe.com/support/Gen10UEFI>

If the UEFI requirements are not met, you might experience boot failures or other errors when installing the operating system.

- Read the operational requirements for the server:

[Operational requirements](#)

- Read the safety and compliance information on the HPE website:

<http://www.hpe.com/support/safety-compliance-enterpriseproducts>

- If the tower-to-rack conversion kit is used, read the rack warnings and cautions:

[Rack warnings and cautions](#)

Procedure

Unbox the server

1. Unbox the server and verify the contents:

- Server
- Power cord
- Rack-mounting hardware (optional)
- Documentation

The server does not ship with OS media. All system software and firmware is preloaded on the server.

Install the hardware options

2. (Optional) Install the hardware options. For installation instructions, see **Hardware options installation**.

Orient the server and connect the peripherals

3. Select the server orientation:

- If the server is in tower mode: **Position the tower server for hardware configuration**.
- If the server is in rack mode: **Remove the server from the rack**.

4. Decide how to manage the server:

- Locally: Use a KVM switch or connect a keyboard, monitor, and mouse.
- Remotely: Connect to the iLO web interface and run a remote console:

- a. Verify the following:

- iLO is licensed to use the remote console feature.

If iLO is not licensed, visit:

<http://www.hpe.com/info/ilo>

- The iLO port is connected to a secure network.

- b. Using a browser, navigate to the iLO web interface, and then log in. The web interface can be accessed by entering the iLO hostname or IP address in the following format:

`https://<iLO hostname or IP address>`

NOTE:

- The iLO hostname is located on the serial number/iLO information label located on the top of the chassis.
 - If a DHCP server assigns the IP address, the IP address appears on the boot screen.
 - If assigned, use the static IP address.
 - The default login credentials are located on the serial number/iLO information pull tab.
-

- c. In the navigation pane, click **Remote Console & Media**, and then launch a remote console.

Power on the server

5. Press the Power On/Standby button.

For remote management, use the iLO virtual power button.

6. Using the SPP, **update the following**:

- System ROM
- Storage controller
- Network adapters
- Intelligent Provisioning

Set up the storage

7. Set up the storage. Do one of the following:

- To configure the server to boot from a SAN, see the following guide:
<https://www.hpe.com/info/boot-from-san-config-guide>
- If an HPE Smart Array SR controller is installed, use the HPE Smart Storage Administrator to create arrays:
 - a. From the boot screen, press **F10** to run Intelligent Provisioning.
 - b. From Intelligent Provisioning, run **HPE Smart Storage Administrator**.
- If no controller option is installed, do one of the following:
 - AHCI is enabled by default. You can deploy an OS or virtualization software.
 - Disable AHCI, enable software RAID, and then create an array:
 - a. From the boot screen, press **F9** to run UEFI System Utilities.
 - b. From the UEFI System Utilities screen, select **System Configurations > BIOS/Platform Configuration (RBSU) > Storage Options > SATA Controller Options > Embedded SATA Configuration > Smart Array SW RAID Support**.
 - c. Enable **Smart Array SW RAID Support**.
 - d. Save the configuration and reboot the server.
 - e. Create an array:
 - I. From the boot screen, press **F9** to run UEFI System Utilities.
 - II. From the UEFI System Utilities screen, select **System Configuration > Embedded Storage: HPE Smart Storage S100i SR Gen10 > Array Configuration > Create Array**.

Deploy an OS or virtualization software

8. Deploy an OS or virtualization software. Do one of the following:

- Press **F10** at the POST screen.
For Intelligent Provisioning 3.30 and later, you are prompted to select whether you want to enter the Intelligent Provisioning or HPE Rapid Setup Software mode. After you have selected a mode, you must reprovision the server to change the mode that launches when you boot to **F10**.
- Manually deploy an OS:
 - a. Insert the installation media.

For remote management, click **Virtual Drives** in the iLO remote console to mount images, drivers, or files to a virtual folder. If a storage driver is required to install the OS, use the virtual folder to store the driver.

- b. Press **F11** at boot screen to select the boot device.
- c. After the OS installation is complete, **update the drivers**.

Register the server

9. To experience quick service and efficient support, register the server at the HPE website:

<https://myenterpriselicense.hpe.com>

Operational requirements

Space and airflow requirements

To allow for servicing and adequate airflow, observe the following space and airflow requirements when deciding where to install a rack:

- Leave a minimum clearance of 63.5 cm (25 in) in front of the rack.
- Leave a minimum clearance of 76.2 cm (30 in) behind the rack.
- Leave a minimum clearance of 121.9 cm (48 in) from the back of the rack to the back of another rack or row of racks.

Hewlett Packard Enterprise servers draw in cool air through the front door and expel warm air through the rear door. Therefore, the front and rear rack doors must be adequately ventilated to allow ambient room air to enter the cabinet, and the rear door must be adequately ventilated to allow the warm air to escape from the cabinet.

⚠ CAUTION: To prevent improper cooling and damage to the equipment, do not block the ventilation openings.

When vertical space in the rack is not filled by a server or rack component, the gaps between the components cause changes in airflow through the rack and across the servers. Cover all gaps with blanking panels to maintain proper airflow.

⚠ CAUTION: Always use blanking panels to fill empty vertical spaces in the rack. This arrangement ensures proper airflow. Using a rack without blanking panels results in improper cooling that can lead to thermal damage.

The 9000 and 10000 Series Racks provide proper server cooling from flow-through perforations in the front and rear doors that provide 64 percent open area for ventilation.

⚠ CAUTION: When using a Compaq branded 7000 series rack, install the high airflow rack door insert (PN 327281-B21 for 42U rack, PN 157847-B21 for 22U rack) to provide proper front-to-back airflow and cooling.

⚠ CAUTION: If a third-party rack is used, observe the following additional requirements to ensure adequate airflow and to prevent damage to the equipment:

- Front and rear doors—If the 42U rack includes closing front and rear doors, you must allow 5,350 sq cm (830 sq in) of holes evenly distributed from top to bottom to permit adequate airflow (equivalent to the required 64 percent open area for ventilation).
 - Side—The clearance between the installed rack component and the side panels of the rack must be a minimum of 7 cm (2.75 in).
-

Temperature requirements

To ensure continued safe and reliable equipment operation, install or position the system in a well-ventilated, climate-controlled environment.

The maximum recommended ambient operating temperature (TMRA) for most server products is 35°C (95°F). The temperature in the room where the rack is located must not exceed 35°C (95°F).

⚠ CAUTION: To reduce the risk of damage to the equipment when installing third-party options:

- Do not permit optional equipment to impede airflow around the server or to increase the internal rack temperature beyond the maximum allowable limits.
 - Do not exceed the manufacturer's TMRA.
-

Power requirements

Installation of this equipment must comply with local and regional electrical regulations governing the installation of information technology equipment by licensed electricians. This equipment is designed to operate in installations covered by NFPA 70, 1999 Edition (National Electric Code) and NFPA-75, 1992 (code for Protection of Electronic Computer/Data Processing Equipment). For electrical power ratings on options, refer to the product rating label or the user documentation supplied with that option.

⚠ WARNING: To reduce the risk of personal injury, fire, or damage to the equipment, do not overload the AC supply branch circuit that provides power to the rack. Consult the electrical authority having jurisdiction over wiring and installation requirements of your facility.

⚠ CAUTION: Protect the server from power fluctuations and temporary interruptions with a regulating uninterruptible power supply. This device protects the hardware from damage caused by power surges and voltage spikes and keeps the system in operation during a power failure.

Electrical grounding requirements

The server must be grounded properly for proper operation and safety. In the United States, you must install the equipment in accordance with NFPA 70, 1999 Edition (National Electric Code), Article 250, as well as any local and regional building codes. In Canada, you must install the equipment in accordance with Canadian Standards Association, CSA C22.1, Canadian Electrical Code. In all other countries, you must install the equipment in accordance with any regional or national electrical wiring codes, such as the International Electrotechnical Commission (IEC) Code 364, parts 1 through 7. Furthermore, you must be sure that all power distribution devices used in the installation, such as branch wiring and receptacles, are listed or certified grounding-type devices.

Because of the high ground-leakage currents associated with multiple servers connected to the same power source, Hewlett Packard Enterprise recommends the use of a PDU that is either permanently wired to the building's branch circuit or includes a nondetachable cord that is wired to an industrial-style plug. NEMA locking-style plugs or those complying with IEC 60309 are considered suitable for this purpose. Using common power outlet strips for the server is not recommended.

Server warnings and cautions

⚠ WARNING: To reduce the risk of personal injury, electric shock, or damage to the equipment, disconnect the power cord to remove power from the server. Pressing the Power On/Standby button does not shut off system power completely. Portions of the power supply and some internal circuitry remain active until AC power is removed.

 **WARNING:** To reduce the risk of personal injury from hot surfaces, allow the drives and the internal system components to cool before touching them.

 **WARNING:** To reduce the risk of fire or burns after removing the energy pack:

- Do not disassemble, crush, or puncture the energy pack.
- Do not short external contacts.
- Do not dispose of the energy pack in fire or water.

After power is disconnected, battery voltage might still be present for 1s to 160s.

 **CAUTION:** Protect the server from power fluctuations and temporary interruptions with a regulating UPS. This device protects the hardware from damage caused by power surges and voltage spikes and keeps the server in operation during a power failure.

 **CAUTION:** To prevent damage to electrical components, properly ground the server before beginning any installation procedure. Improper grounding can cause electrostatic discharge.

 **CAUTION:** To avoid data loss, Hewlett Packard Enterprise recommends that you back up all server data before installing or removing a hardware option, or performing a server maintenance or troubleshooting procedure.

 **CAUTION:** Do not operate the server for long periods with the access panel open or removed. Operating the server in this manner results in improper airflow and improper cooling that can lead to thermal damage.

Rack warnings and cautions

 **WARNING:** When all components are removed, the server weighs 6.12 kg (13.49 lb). When all components are installed, the server can weigh up to 17.60 kg (38.80 lb).

Before configuring your rack solution, be sure to check the rack manufacturer weight limits and specifications. Failure to do so can result in physical injury or damage to the equipment and the facility.

 **WARNING:** The server is heavy. To reduce the risk of personal injury or damage to the equipment, do the following:

- Observe local occupational health and safety requirements and guidelines for manual material handling.
 - Get help to lift and stabilize the product during installation or removal, especially when the product is not fastened to the rails. The server weighs more than 6.12 kg (13.49 lb), so at least two people must lift the server into the rack together. An additional person may be required to help align the server if the server is installed higher than chest level.
 - Use caution when installing the server in or removing the server from the rack.
 - Adequately stabilize the rack before extending a component outside the rack. Extend only one component at a time. A rack may become unstable if more than one component is extended.
 - Do not stack anything on top of rail-mounted component or use it as a work surface when extended from the rack.
-



WARNING: To reduce the risk of personal injury or damage to the equipment, observe the following precautions:

- The leveling jacks are extended to the floor.
 - The full weight of the rack rests on the leveling jacks.
 - The stabilizing feet are attached to the rack if it is a single-rack installation.
 - The racks are coupled together in multiple-rack installations.
-



WARNING: To reduce the risk of personal injury or equipment damage when unloading a rack:

- At least two people are needed to safely unload the rack from the pallet. An empty 42U rack can weigh as much as 115 kg (253 lb), can stand more than 2.1 m (7 ft) tall, and might become unstable when being moved on its casters.
 - Never stand in front of the rack when it is rolling down the ramp from the pallet. Always handle the rack from both sides.
-



CAUTION: Always plan the rack installation so that the heaviest item is on the bottom of the rack. Install the heaviest item first, and continue to populate the rack from the bottom to the top.



CAUTION: Before installing the server in a rack, be sure to properly scope the limitations of the rack. Before proceeding with the installation, consider the following:

- You must fully understand the static and dynamic load carrying capacity of the rack and be sure that it can accommodate the weight of the server.
 - Be sure sufficient clearance exists for cabling, installation and removal of the server, and movement of the rack doors.
-

Preventing electrostatic discharge

To prevent damaging the system, be aware of the precautions you must follow when setting up the system or handling parts. A discharge of static electricity from a finger or other conductor may damage system boards or other static-sensitive devices. This type of damage may reduce the life expectancy of the device.

Procedure

- Avoid hand contact by transporting and storing products in static-safe containers.
- Keep electrostatic-sensitive parts in their containers until they arrive at static-free workstations.
- Place parts on a grounded surface before removing them from their containers.
- Avoid touching pins, leads, or circuitry.
- Always be properly grounded when touching a static-sensitive component or assembly.

POST screen options

When the server is powered on, the POST screen is displayed. The following options are displayed:

- **System Utilities (F9)**

Use this option to configure the system BIOS.

- **Intelligent Provisioning (F10)**

Use this option to deploy an operating system or configure storage.

- **Boot order (F11)**

Use this option to make a one-time boot selection.

- **Network boot (F12)**

Use this option to boot the server from the network.

Installing or deploying an operating system

Before installing an operating system, observe the following:

- Be sure to read the HPE UEFI requirements for ProLiant servers on the **Hewlett Packard Enterprise website**. If UEFI requirements are not met, you might experience boot failures or other errors when installing the operating system.
- Update firmware before using the server for the first time, unless software or components require an older version. For more information, see **Keeping the system current**.
- For the latest information on supported operating systems, see the **Hewlett Packard Enterprise website**.
- The server does not ship with OS media. All system software and firmware is preloaded on the server.

Hardware options installation

Product QuickSpecs

For more information about product features, specifications, options, configurations, and compatibility, see the product QuickSpecs on the Hewlett Packard Enterprise website (<http://www.hpe.com/info/qs>).

Introduction

Install any hardware options before initializing the server. For options installation information, see the option documentation. For server-specific information, use the procedures in this section.

If multiple options are being installed, read the installation instructions for all the hardware options to identify similar steps and streamline the installation process.



WARNING: To reduce the risk of personal injury from hot surfaces, allow the drives and the internal system components to cool before touching them.



CAUTION: To prevent damage to electrical components, properly ground the server before beginning any installation procedure. Improper grounding can cause electrostatic discharge.

Tower to rack conversion kit

Installing the tower-to-rack conversion kit

Use the tower-to-rack conversion kit to switch the tower server to rack mode operation. In this procedure, left and right terminology is from the perspective of a user facing the front of the rack.

Procedure

1. **Review the rack warnings and cautions.**
2. If the server is used in tower mode, **prepare the server for rack installation.**
3. **Install the rack rails and server tray.**
4. **Install the server on the tray.**

Preparing the server for rack installation

Procedure

1. **Power down the server.**
2. Remove all power:
 - a. Disconnect each power cord from the power source.
 - b. Disconnect each power cord from the server.
3. Disconnect all peripheral cables from the server.

4. If installed, unlock and remove the security padlock and/or the Kensington security lock.
For more information, see the lock documentation.
5. **Place the server on the side and access panel facing up.**

Installing the rack rails and server tray

These rack rails can be installed in both round-hole or square-hole racks.

Prerequisites

Before you perform this procedure, make sure that you have the following items available:

- Left and right rack rail assemblies – These rails occupy 1U position on the rack.
- Server tray
- T-15 Torx screwdriver

Procedure

1. Disassemble the rail assemblies:

- a. Pull out the inner rail until it is fully extended.
- b. Slide and hold the white release tab in the direction shown, and then remove the inner sliding rail from the outer mounting rail.

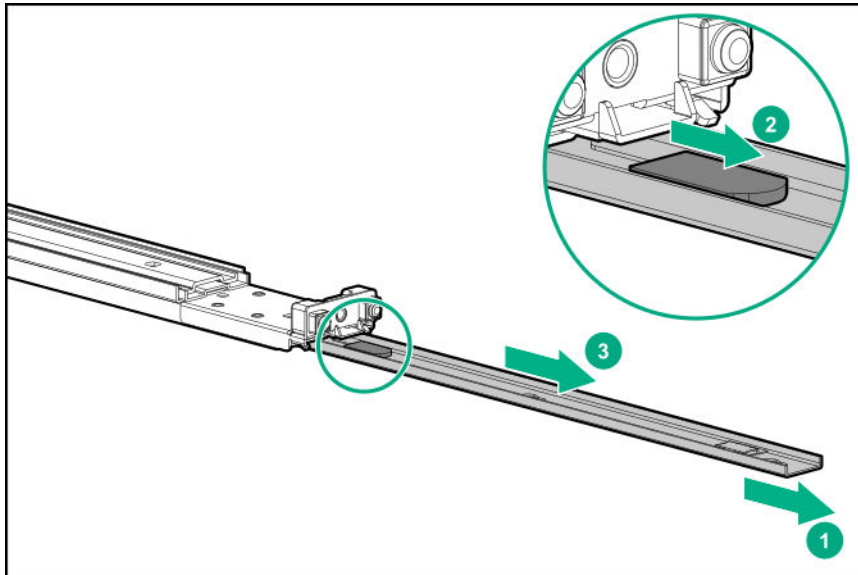

- c. Repeat steps a–b on the other rail assembly.
2. Install the sliding rails on the server tray:
 - a. Align the notches on the rail with the pins on the side.
 - b. Slide the rail towards the rear of the tray to lock it into place.

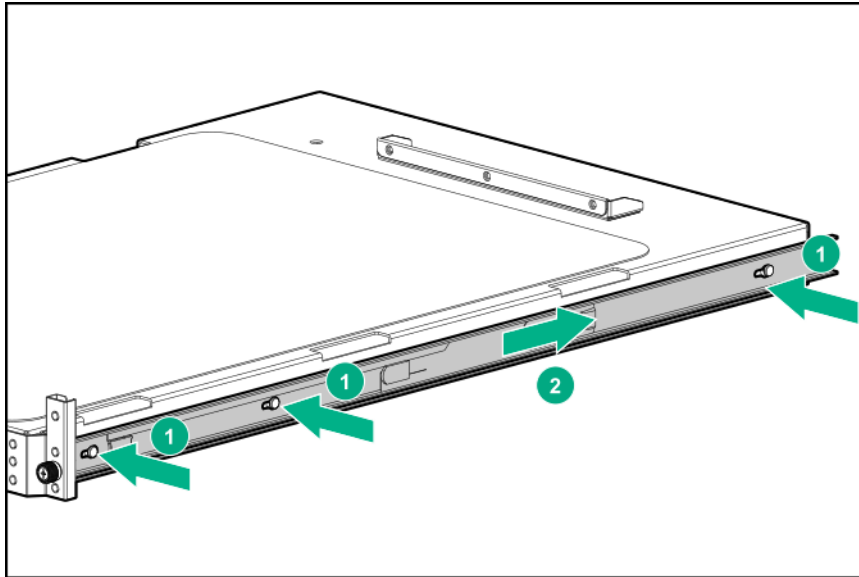

c. Repeat steps a–b on the other inner rail.

3. Locate the orientation markers on the mounting rails:

- The front end of the rails is marked **FRONT**.
- The rear end of the rails is marked with **L** for left and **R** for right.

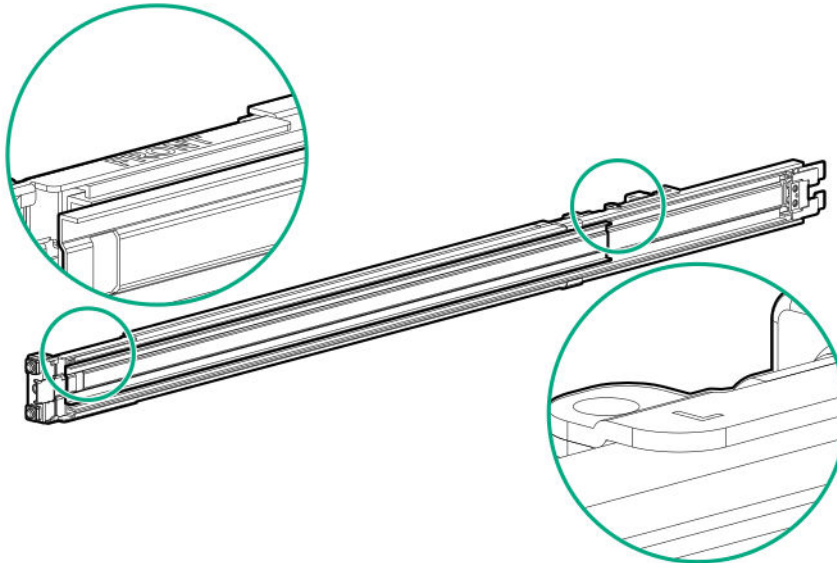

4. Fasten the mounting rails to the rack columns:

- a. Retract and hold the rear retention bracket.
- b. Insert the pegs on the mounting flange into the rack holes.
- c. Release the rear retention bracket.

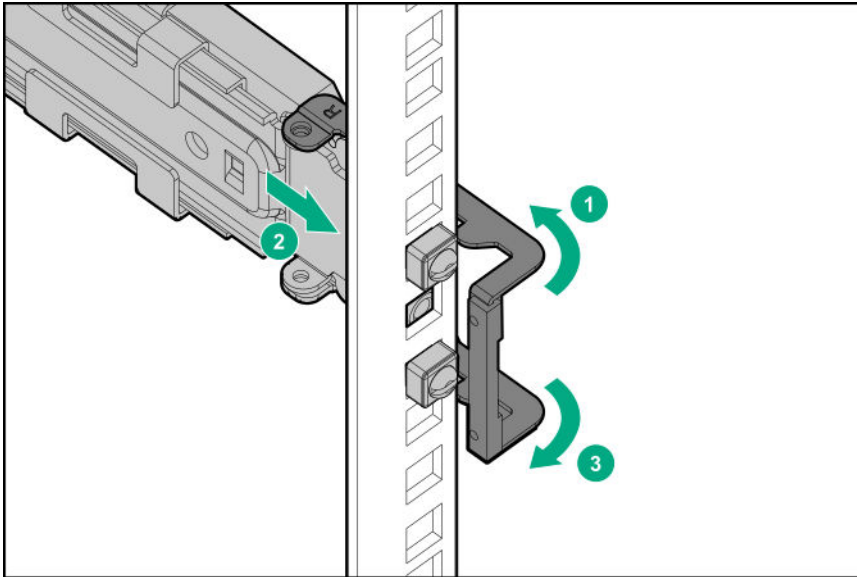

- d.** Retract and hold the front retention bracket.
- e.** Insert the pegs on the mounting flange into the rack holes.
- f.** Release the front retention bracket.

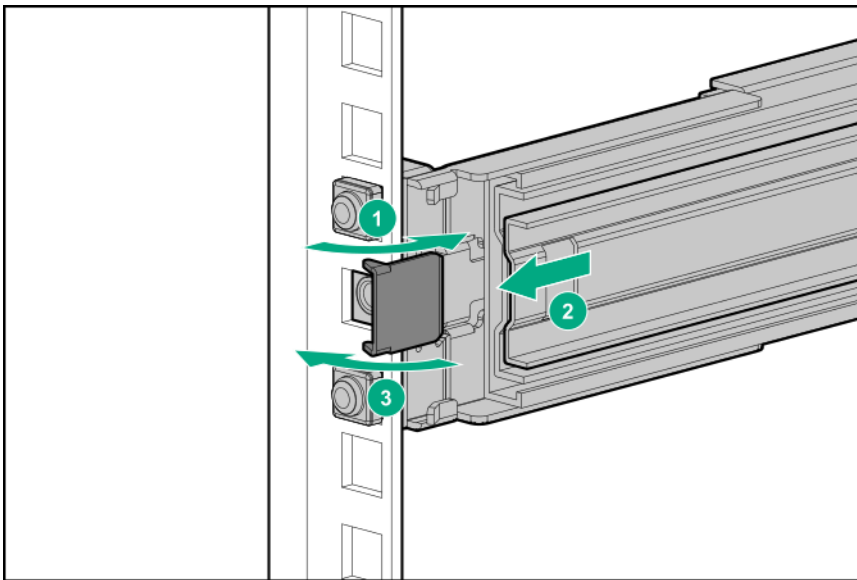

- g.** Repeat steps a-f to fasten the other mounting rail.
 - h.** Make sure that both rails are mounted at the same vertical position on both sides of the rack.
- 5.** Slide the server tray into the rack.
The rails will click and lock into place when the tray is properly engaged.

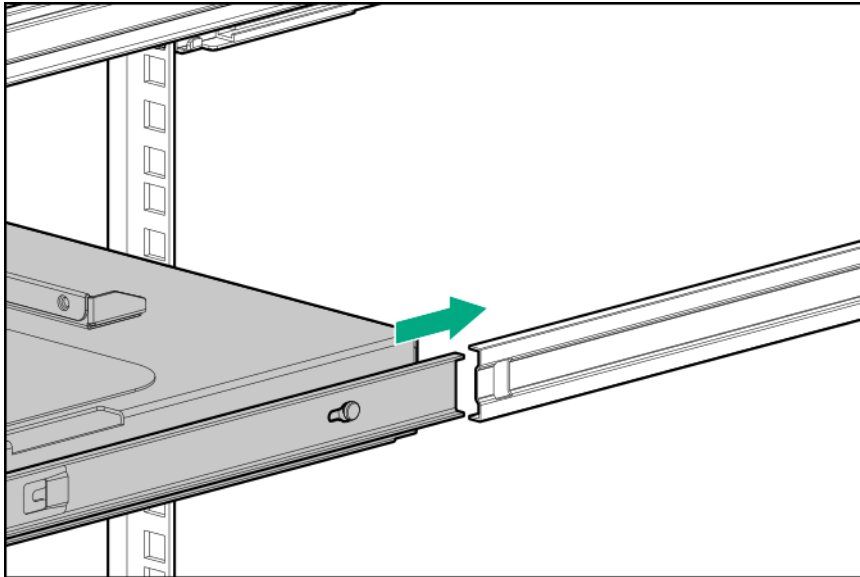

The installation is complete.

Installing the server on the tray

Procedure

1. Grasp the tray notch to slide the tray out of the rack.

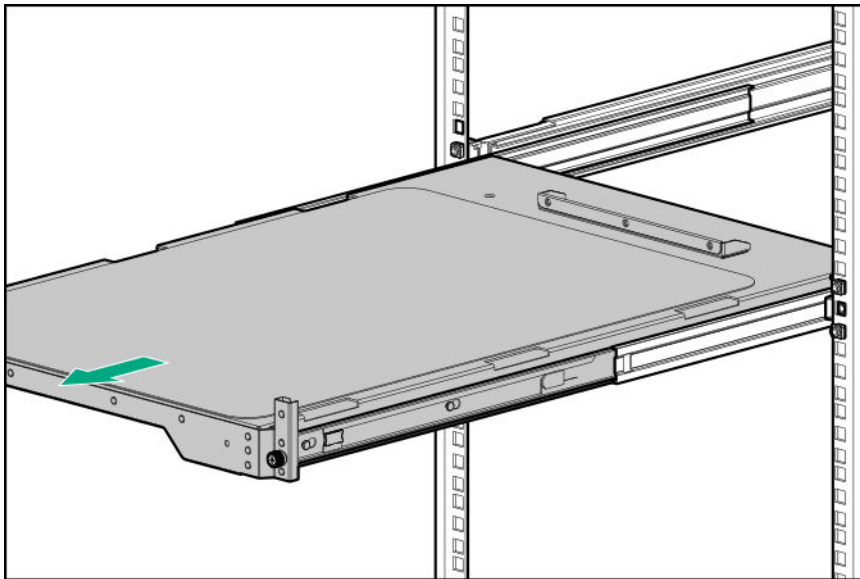

2. Place the server on the tray.

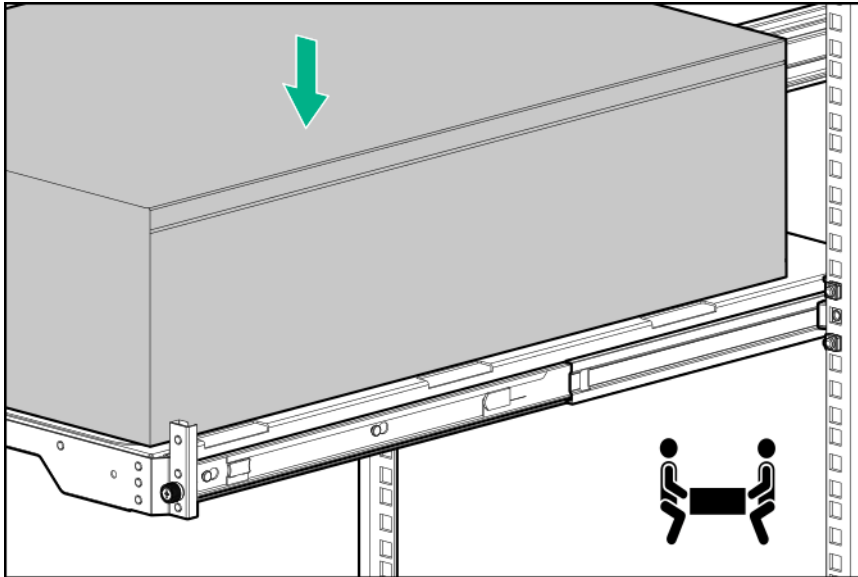

- 3. Slide the server into the rack.**
- 4.** Connect all peripheral cables to the server.
- 5.** Connect the power cords:
 - a.** Connect each power cord to the server.
 - b.** Connect each power cord to the power source.
- 6. Power up the server.**

The installation is complete.

Installing the PCI fan and air baffle options

The PCI fan option is required to meet the system thermal requirement when any of the following expansion board options are installed:

- Type-p Smart Array controllers
- High-performance NIC controllers
- 10 GB Ethernet adapters
- GPUs
- M.2 SSDs
- Third-party expansion boards

NOTE: A PCI fan is also required while the server is in rack mode.

⚠ CAUTION: For proper cooling, do not operate the server without the access panel, baffles, expansion slot covers, or blanks installed. If the server supports hot-plug components, minimize the amount of time the access panel is open.

Prerequisites

Before you perform this procedure, make sure that you have a T-15 Torx screwdriver available.

Procedure

1. **Power down the server.**
2. Remove all power:
 - a. Disconnect each power cord from the power source.
 - b. Disconnect each power cord from the server.
3. Disconnect all peripheral cables from the server.
4. Do one of the following:
 - If the server is in tower mode: **Position the tower server for hardware configuration.**
 - If the server is in rack mode: **Remove the server from the rack.**
5. **Remove the front bezel.**
6. **Remove the access panel.**
7. Install the PCI fan option:
 - a. Mount the fan on the chassis.
 - b. Verify that the guiding pins on the fan guard are inserted into the chassis opening.
 - c. Secure the fan with the screws.
 - d. Connect the fan cable.

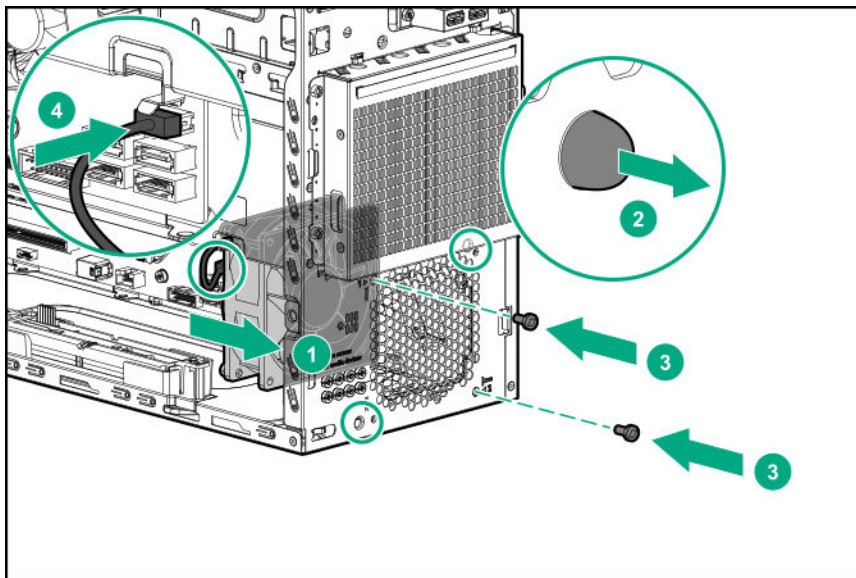

8. Install the air baffle:
 - a. Insert the tabs on the baffle into the slots on the rear chassis.
 - b. Press the front end of the baffle into the chassis.

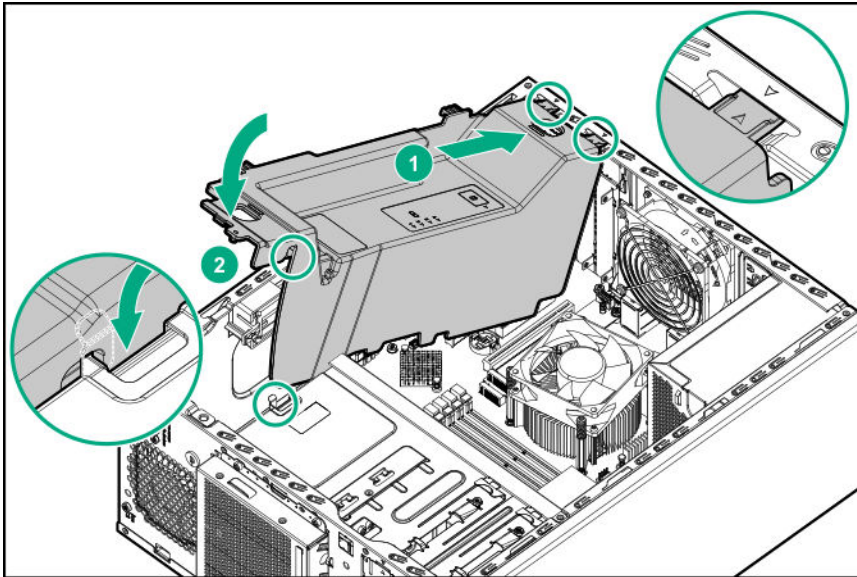

9. **Install the access panel.**
10. **Install the front bezel.**
11. Do one of the following:
 - If the server is in tower mode: **Position the tower server for operation.**
 - If the server is in rack mode: **Install the server on the tray.**
12. Connect all peripheral cables to the server.
13. Connect the power cords:
 - a. Connect each power cord to the server.
 - b. Connect each power cord to the power source.
14. **Power up the server.**

The installation is complete.

Drive options

Drive installation guidelines

Observe the following general guidelines:

- The system automatically sets all drive numbers.
- If only one drive is used, install it in the bay with the lowest drive number.

For drive numbering, see **Drive bay numbering.**

- Drives with the same capacity provide the greatest storage space efficiency when grouped into the same drive array.

Drive support information

Depending on the drive cage installed, the server supports the following drives:

- Non-hot-plug LFF SATA drives
- Hot-plug LFF SATA or SAS drives
- Hot-plug SFF SATA or SAS drives

The server supports up to eight drives in the SFF configuration and four drives in the LFF configuration.

The embedded HPE Smart Array S100i SR Gen10 Controller supports SATA drive installation. For SAS drive installation, **install a type-p standup plug-in Smart Array controller option.**

Installing an LFF non-hot-plug drive in the drive cage

Prerequisites

Before you perform this procedure, make sure that you have a T-15 Torx screwdriver available.

Procedure

- 1. Power down the server.**
- 2. Remove all power:**
 - a. Disconnect each power cord from the power source.**
 - b. Disconnect each power cord from the server.**
- 3. Disconnect all peripheral cables from the server.**
- 4. Do one of the following:**
 - If the server is in tower mode: **Position the tower server for hardware configuration.**
 - If the server is in rack mode: **Remove the server from the rack.**
- 5. Remove the front bezel.**
- 6. Remove the access panel.**
- 7. If installed, remove the air baffle.**
- 8. If there are drives already installed in the non-hot-plug drive cage, disconnect all cables from the drives.**
- 9. Remove the non-hot-plug drive cage:**
 - a. Remove the screws from the drive cage.**
 - b. Remove the non-hot-plug drive cage.**

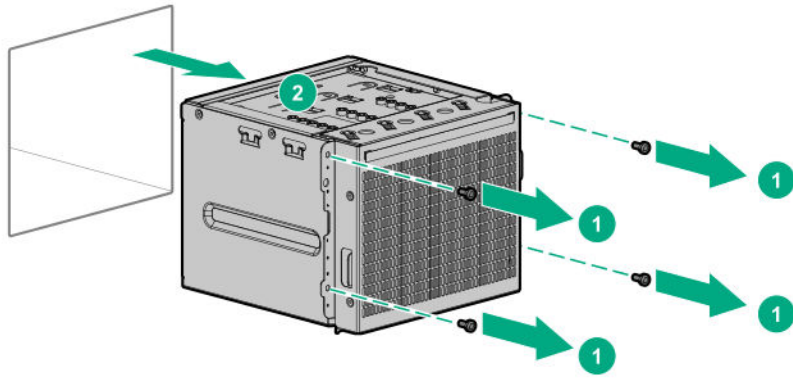

10. Install the drive.

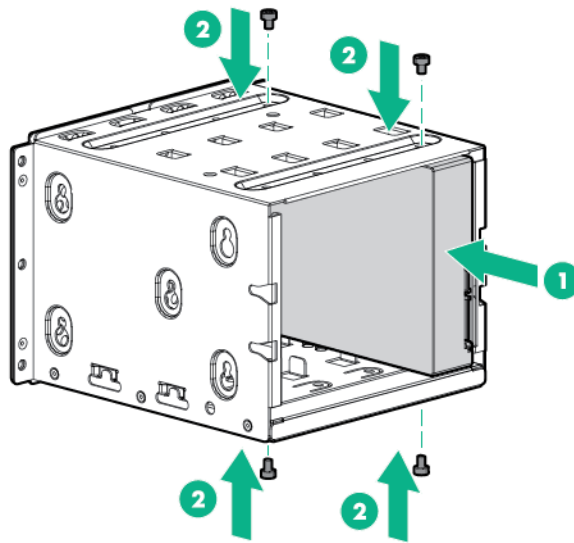

11. Install the non-hot-plug drive cage.

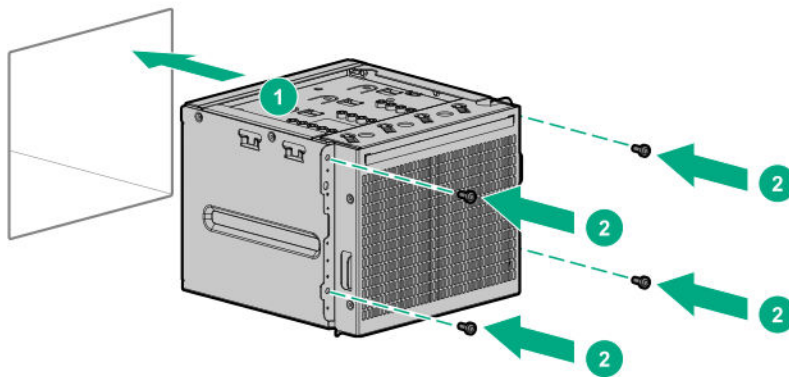

12. **Connect the drive cables.**

13. If removed, **install the air baffle.**

14. Install the access panel.

15. Install the front bezel.

16. Do one of the following:

- If the server is in tower mode: **Position the tower server for operation.**
- If the server is in rack mode: **Install the server on the tray.**

17. Connect all peripheral cables to the server.

18. Connect the power cords:

- a. Connect each power cord to the server.
- b. Connect each power cord to the power source.

19. Power up the server.

The installation is complete.

To configure arrays, see the *HPE Smart Array SR Gen10 Configuration Guide* at the **Hewlett Packard Enterprise website.**

Installing an LFF hot-plug drive

⚠ CAUTION: To prevent improper cooling and thermal damage, do not operate the server unless all bays are populated with either a component or a blank.

Procedure

1. Remove the front bezel.

2. Remove the drive blank.

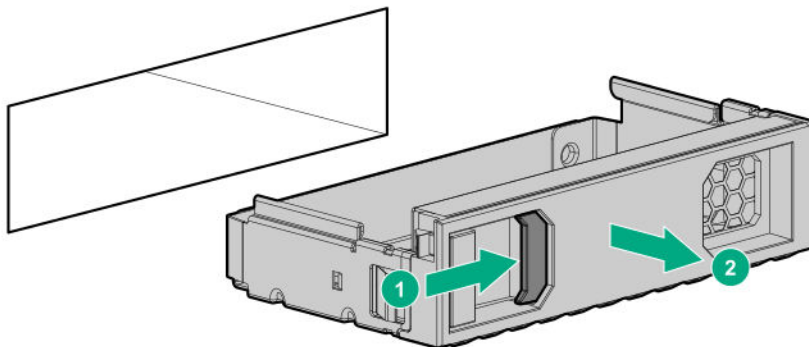

3. Prepare the drive.

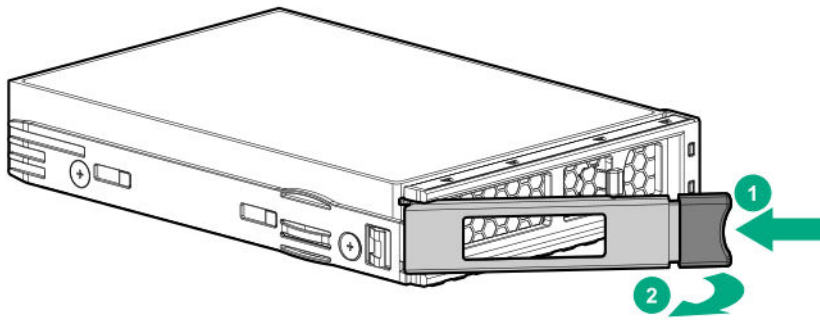

4. Install the drive.

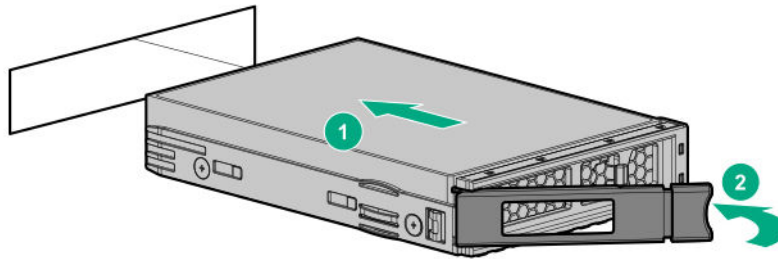

5. If the drive is installed in an empty drive cage after the initial system boot, reboot the system to maintain optimal ventilation.

6. **Determine the status of the drive from the drive LED definitions.**

7. **Install the front bezel.**

The installation is complete.

To configure arrays, see the *HPE Smart Array SR Gen10 Configuration Guide* at the **Hewlett Packard Enterprise website**.

Installing an SFF hot-plug drive

- ⚠ CAUTION:** To prevent improper cooling and thermal damage, do not operate the server unless all bays are populated with either a component or a blank.

Procedure

1. **Remove the front bezel.**

2. Remove the drive blank.

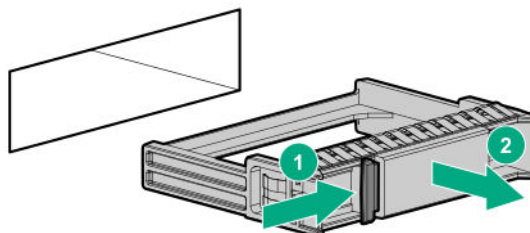

3. Prepare the drive.

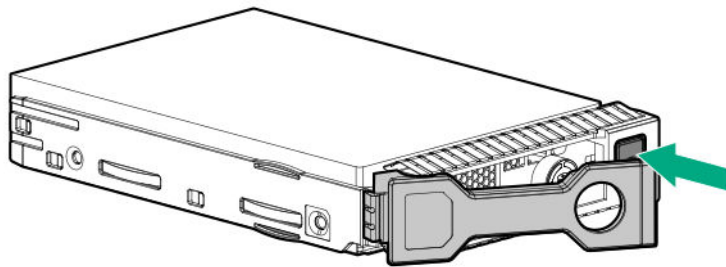

4. Install the SFF drive.

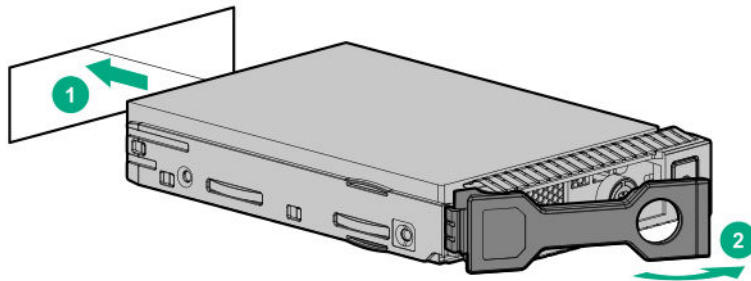

5. If the drive is installed in an empty drive cage after the initial system boot, reboot the system to maintain optimal ventilation.
6. **Determine the status of the drive from the drive LED definitions.**
7. **Install the front bezel.**

The installation is complete.

To configure arrays, see the *HPE Smart Array SR Gen10 Configuration Guide* at the **[Hewlett Packard Enterprise website](http://www.hpe.com/enterprise)**.

Power supply options

Depending on the installed options and the regional location where the server was purchased, the server can be configured with one of the following power supplies:

- **HPE 350W E-star 1.0 Non-hot-plug Power Supply**
- **HPE 500W Flex Slot Platinum Hot-plug Low Halogen Power Supply**

Hot-plug power supply calculations

For more information on the hot-plug power supply and calculators to determine server power consumption in various system configurations, see the Hewlett Packard Enterprise Power Advisor website (**<http://www.hpe.com/info/poweradvisor/online>**).

Power supply warnings and cautions



WARNING: To reduce the risk of electric shock or damage to the equipment:

- Do not disable the power cord grounding plug. The grounding plug is an important safety feature.
 - Plug the power cord into a grounded (earthed) electrical outlet that is easily accessible at all times.
 - Unplug the power cord from the power supply to disconnect power to the equipment.
 - Do not route the power cord where it can be walked on or pinched by items placed against it. Pay particular attention to the plug, electrical outlet, and the point where the cord extends from the server.
-



WARNING: To reduce the risk of injury from electric shock hazards, do not open power supplies. Refer all maintenance, upgrades, and servicing to qualified personnel



WARNING: To reduce the risk of personal injury from hot surfaces, allow the drives and the internal system components to cool before touching them.



CAUTION: To prevent damage to electrical components, properly ground the server before beginning any installation procedure. Improper grounding can cause electrostatic discharge.



CAUTION: Mixing different types of power supplies in the same server might:

- Limit or disable some power supply features including support for power redundancy.
- Cause the system to become unstable and might shut down.

To ensure access to all available features, all power supplies in the same server should have the same output and efficiency ratings. Verify that all power supplies have the same part number and label color.

Flexible Slot (Redundant) power supply enablement option

The Flexible Slot (Redundant) power supply enablement option supports the installation of two Gen10 Flexible Slot (Flex Slot) power supplies.

Adding a second power supply provides redundant power support to the server if one power supply fails. Do not power down the server before removing or installing a redundant hot-plug power supply.

Installing a Flexible Slot (Redundant) power supply enablement option

Prerequisites

- Before installing the Flexible Slot (Redundant) power supply enablement option, read the **power supply warnings and cautions**.
- Before you perform this procedure, make sure that you have the following items available:
 - Flexible Slot (Redundant) power supply enablement option
 - Hot-plug power supply
 - T-15 Torx screwdriver

Procedure

1. **Power down the server.**
2. Remove all power:
 - a. Disconnect each power cord from the power source.
 - b. Disconnect each power cord from the server.
3. Disconnect all peripheral cables from the server.
4. Do one of the following:
 - If the server is in tower mode: **Position the tower server for hardware configuration.**
 - If the server is in rack mode: **Remove the server from the rack.**
5. **Remove the front bezel.**
6. **Remove the access panel.**
7. If installed, **remove the air baffle.**
8. Disconnect all power supply cables from the system board, drive cages, and devices.
9. Remove the standard power supply.

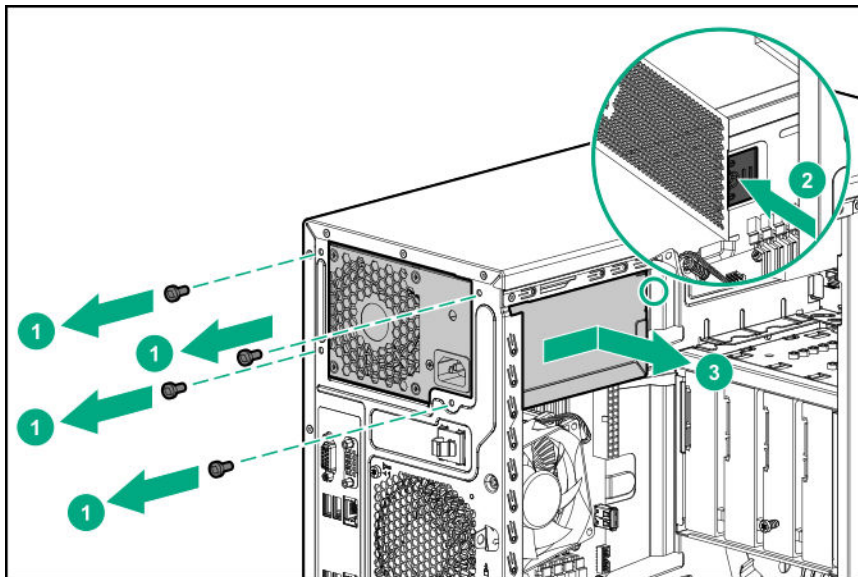

10. Install the RPS cage.

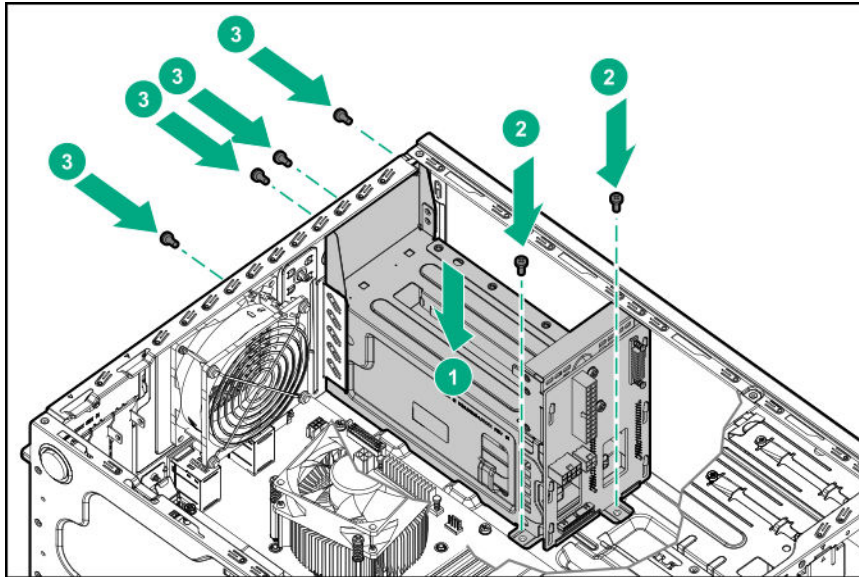

11. Connect the flexible slot power supply backplane cables.

12. Install a hot-plug power supply in the power supply bay 1.

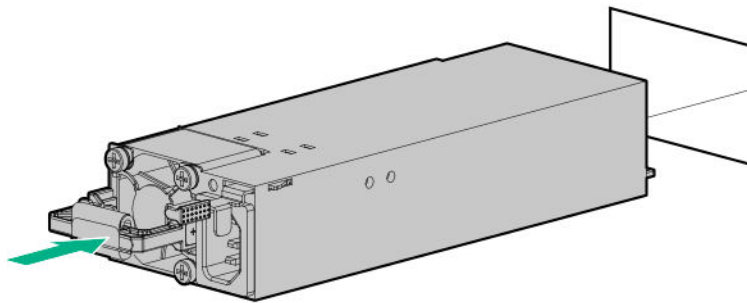

13. To enable power redundancy in the server, install a second power supply in the power supply bay 2:

- a.** Remove the power supply blank from bay 2.

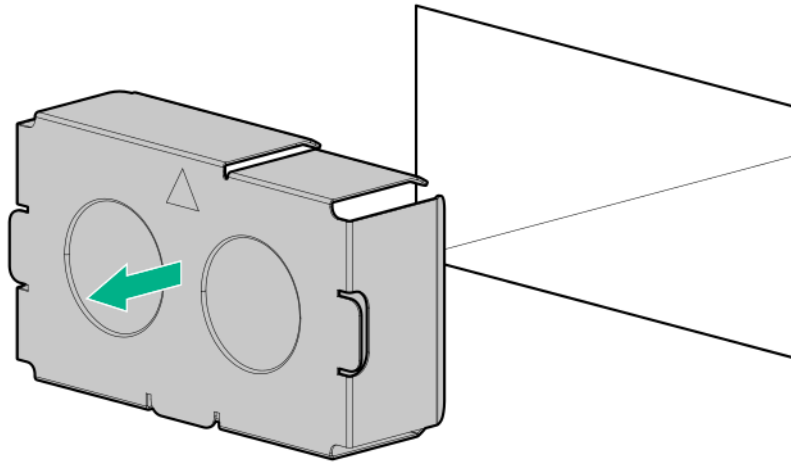

b. Repeat step **12** to install a second hot-plug power supply in power supply bay 2.

14. If removed, **install the air baffle.**

15. **Install the access panel.**

16. **Install the front bezel.**

17. Do one of the following:

- If the server is in tower mode: **Position the tower server for operation.**
- If the server is in rack mode: **Install the server on the tray.**

18. Connect all peripheral cables to the server.

19. Connect the power cords:

- a. Connect each power cord to the server.
- b. Connect each power cord to the power source.

20. **Power up the server.**

The installation is complete.

Media device options

The server supports the following media device options:

- **SAS LTO tape drive**
- **USB RDX tape drive**
- **SATA optical drive**
- **LFF non-hot-plug drive**

Installing a SAS LTO tape drive

- ⚠ CAUTION:** To prevent improper cooling and thermal damage, do not operate the server unless all bays are populated with either a component or a blank.

The media bay 1 supports the installation of a SAS LTO tape drive option.

Prerequisites

Before you perform this procedure:

- **Make sure that a Smart Array controller option is installed.**
- T-15 Torx screwdriver is available.

Procedure

1. **Power down the server.**
2. Remove all power:
 - a. Disconnect each power cord from the power source.
 - b. Disconnect each power cord from the server.
3. Disconnect all peripheral cables from the server.
4. Do one of the following:
 - If the server is in tower mode: **Position the tower server for hardware configuration.**
 - If the server is in rack mode: **Remove the server from the rack.**
5. **Remove the front bezel.**
6. **Remove the access panel.**
7. If installed, **remove the air baffle.**
8. Remove the EMI shield.

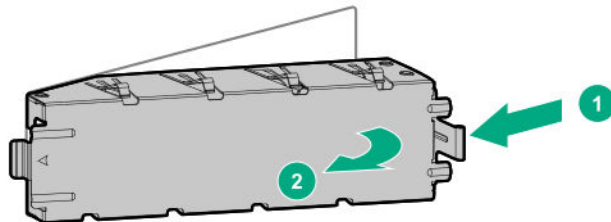

9. Secure the metal shims on the LTO tape drive.
The shims and the screws are included in the LTO tape drive option kit.

If you are installing an LTO tape drive that does not include its own mounting screws, use the **media device screws.**

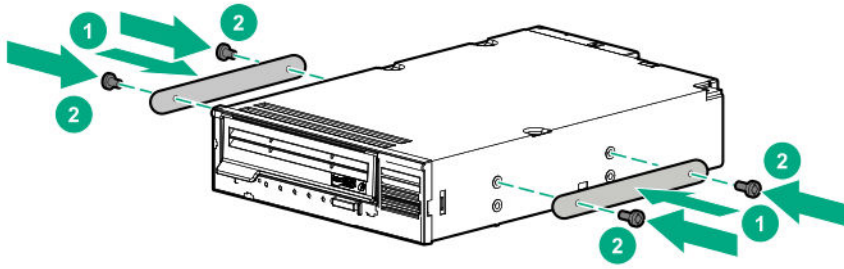

10. Slide the LTO tape drive into the media bay until it clicks into place.

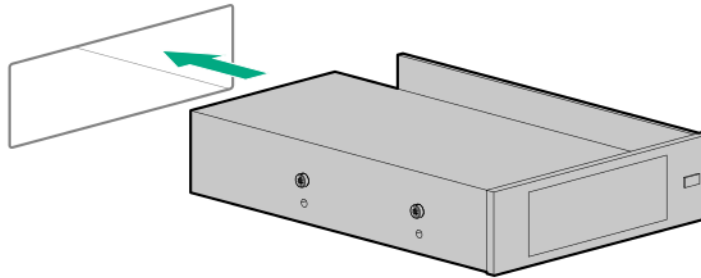

11. Connect the drive cables.

12. If removed, **install the air baffle.**

13. Install the access panel.

14. Install the front bezel.

15. Do one of the following:

- If the server is in tower mode: **Position the tower server for operation.**
- If the server is in rack mode: **Install the server on the tray.**

16. Connect all peripheral cables to the server.

17. Connect the power cords:

- a.** Connect each power cord to the server.
- b.** Connect each power cord to the power source.

18. Power up the server.

19. Perform the verification and configuration procedures required by the drive option.

For more information, see the drive user guide from the Storage section of the **Hewlett Packard Enterprise Information Library.**

The installation is complete.

Installing a USB RDX drive

CAUTION: To prevent improper cooling and thermal damage, do not operate the server unless all bays are populated with either a component or a blank.

Prerequisites

Before you perform this procedure, make sure that you have a T-15 Torx screwdriver available.

Procedure

1. **Power down the server.**
2. Remove all power:
 - a. Disconnect each power cord from the power source.
 - b. Disconnect each power cord from the server.
3. Disconnect all peripheral cables from the server.
4. Do one of the following:
 - If the server is in tower mode: **Position the tower server for hardware configuration.**
 - If the server is in rack mode: **Remove the server from the rack.**
5. **Remove the front bezel.**
6. **Remove the access panel.**
7. If installed, **remove the air baffle.**
8. Remove the EMI shield.

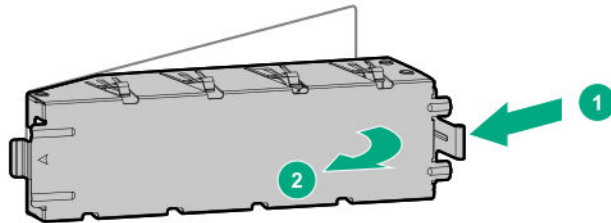

9. Secure the RDX drive screws.

These screws are included in the RDX drive option kit. If you are installing an RDX drive that does not include its own mounting screws, use the **media device screws**.

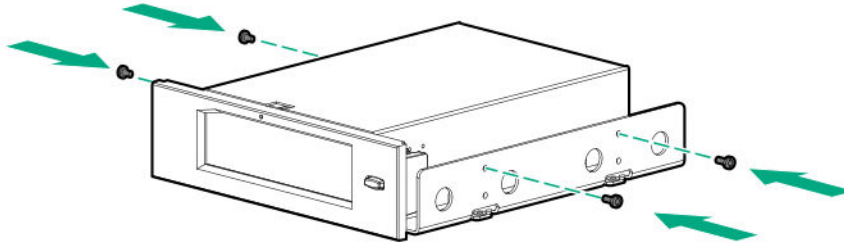

10. Slide the RDX drive into the media drive bay until it clicks into place.

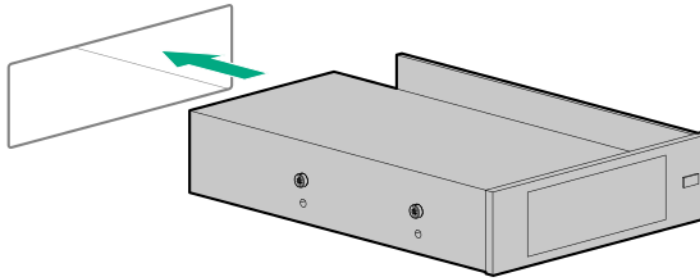

11. **Connect the drive cables.**
12. If removed, **install the air baffle.**
13. **Install the access panel.**
14. **Install the front bezel.**
15. Do one of the following:
 - If the server is in tower mode: **Position the tower server for operation.**
 - If the server is in rack mode: **Install the server on the tray.**
16. Connect all peripheral cables to the server.
17. Connect the power cords:
 - a. Connect each power cord to the server.
 - b. Connect each power cord to the power source.
18. **Power up the server.**
19. Perform the verification and configuration procedures required by the drive option.

For more information, see the drive user guide from the Storage section of the **Hewlett Packard Enterprise Information Library.**

The installation is complete.

Installing an optical drive

- ⚠ CAUTION:** To prevent improper cooling and thermal damage, do not operate the server unless all bays are populated with either a component or a blank.

Prerequisites

Before you perform this procedure, make sure that you have the following tools available:

- Phillips No. 1 screwdriver
- T-15 Torx screwdriver

Procedure

- 1. Power down the server.**
- Remove all power:
 - a. Disconnect each power cord from the power source.
 - b. Disconnect each power cord from the server.
- Disconnect all peripheral cables from the server.
- Do one of the following:
 - If the server is in tower mode: **Position the tower server for hardware configuration.**
 - If the server is in rack mode: **Remove the server from the rack.**
- Remove the front bezel.**
- Remove the access panel.**
- If installed, **remove the air baffle.**
- Remove the EMI shield.

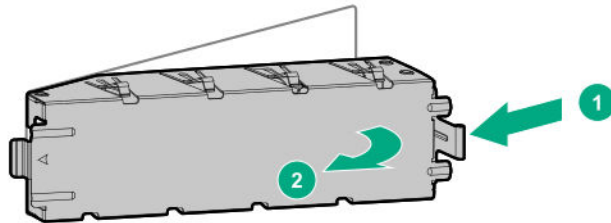

9. Install the optical drive bracket.

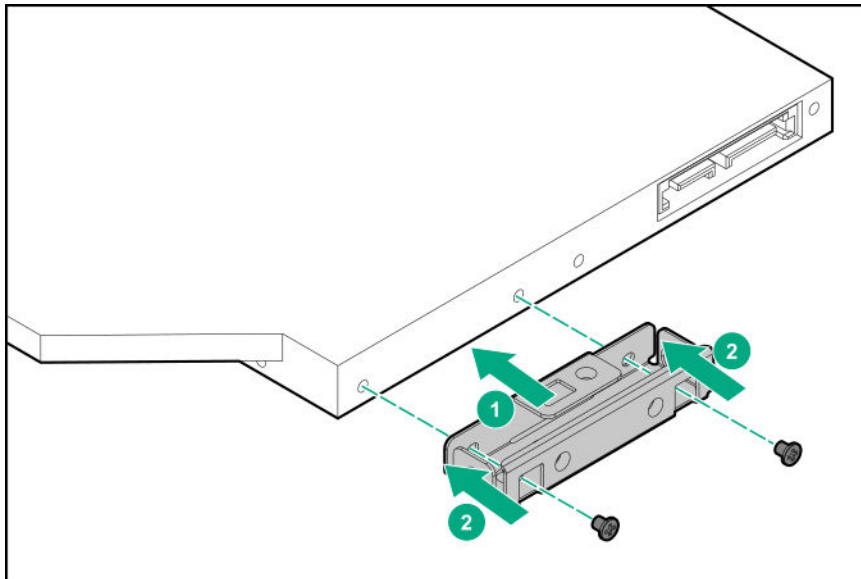

10. Remove the four media device screws from the front panel.

11. Install the optical drive in the optical drive cage:

- a. Slide the optical drive into the optical drive cage.
- b. Secure the drive to the cage with the two screws, and then with the four media device screws.

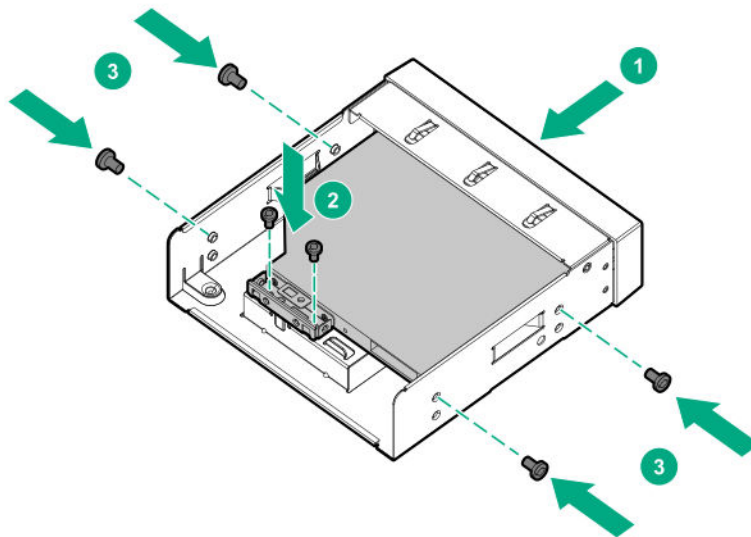

12. Connect the SATA-power Y-cable to the drive, and then route the cable through the clip on the optical drive cage.

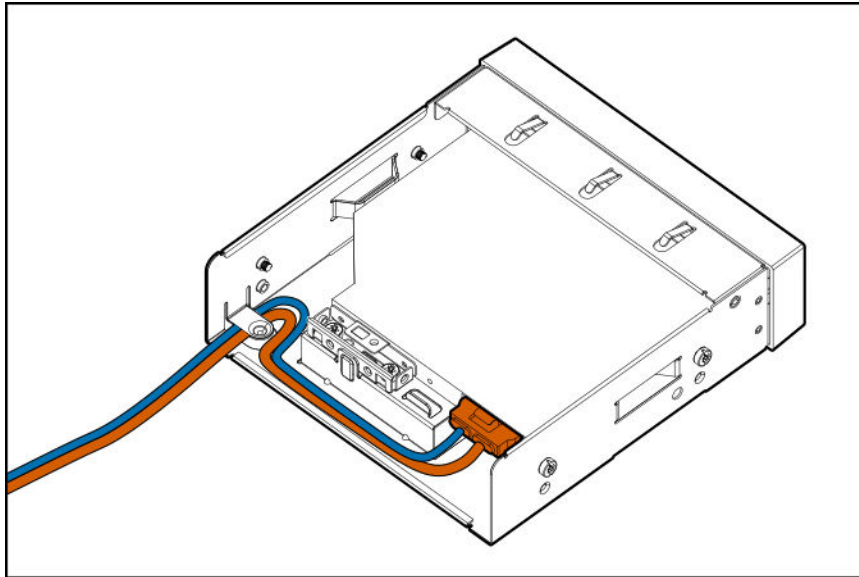

13. Slide the optical drive assembly into the media bay until it clicks into place.

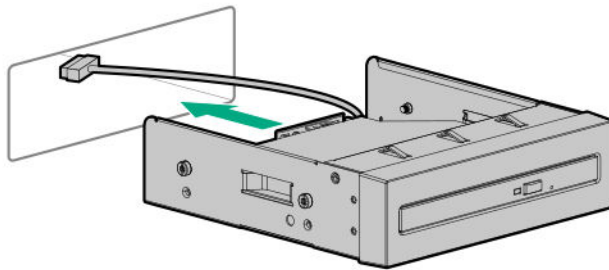

14. **Connect the optical drive SATA-power Y-cable.**
15. If removed, **install the air baffle.**
16. **Install the access panel.**
17. **Install the front bezel.**
18. Do one of the following:
 - If the server is in tower mode: **Position the tower server for operation.**
 - If the server is in rack mode: **Install the server on the tray.**
19. Connect all peripheral cables to the server.
20. Connect the power cords:
 - a. Connect each power cord to the server.
 - b. Connect each power cord to the power source.
21. **Power up the server.**

The installation is complete.

Installing an LFF non-hot-plug drive in the media drive bay

- ⚠ CAUTION:** To prevent improper cooling and thermal damage, do not operate the server unless all bays are populated with either a component or a blank.

Use the LFF drive enablement option to install non-hot-plug LFF SATA drives in the media bays.

Prerequisites

Before you perform this procedure, make sure that you have a T-15 Torx screwdriver available.

Procedure

- 1. Power down the server.**
- Remove all power:
 - Disconnect each power cord from the power source.
 - Disconnect each power cord from the server.
- Disconnect all peripheral cables from the server.
- Do one of the following:
 - If the server is in tower mode: **Position the tower server for hardware configuration.**
 - If the server is in rack mode: **Remove the server from the rack.**
- Remove the front bezel.**
- Remove the access panel.**
- If installed, **remove the air baffle.**
- Remove the EMI shield.

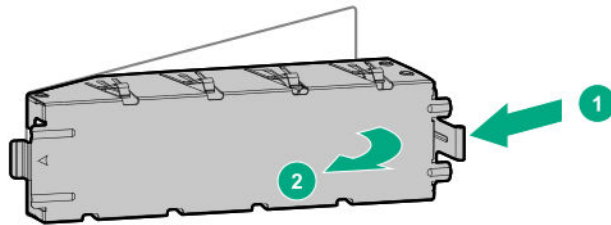

- Slide the drive into the drive cage and secure it with the screws included in the option kit.

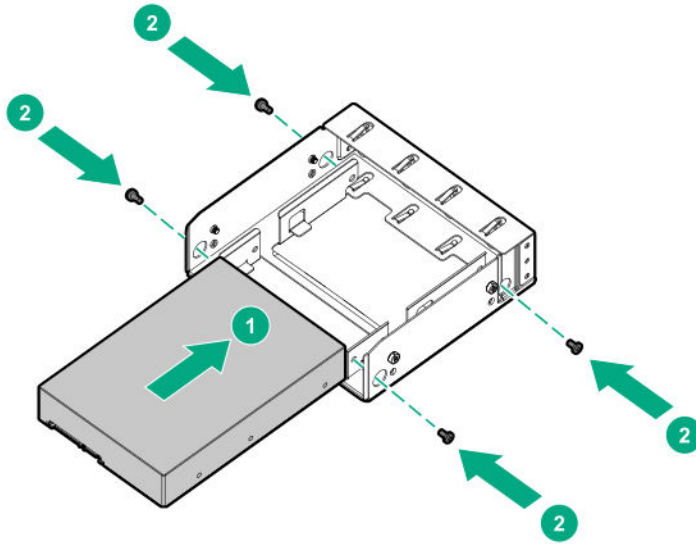

10. Remove the four media device screws from the front panel.

11. Install the media device screws in the drive cage.

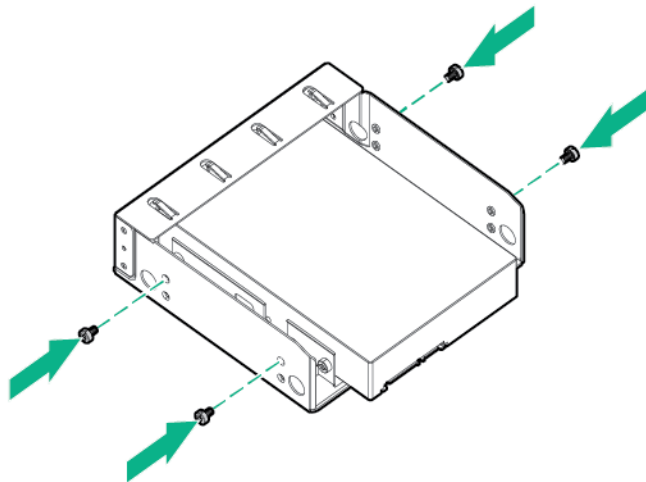

12. Slide the drive cage into the media bay until it locks into place.

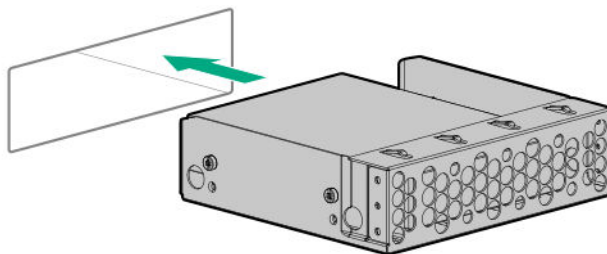

13. Connect the drive cables.

14. If removed, **install the air baffle.**
15. **Install the access panel.**
16. **Install the front bezel.**
17. Do one of the following:
 - If the server is in tower mode: **Position the tower server for operation.**
 - If the server is in rack mode: **Install the server on the tray.**
18. Connect all peripheral cables to the server.
19. Connect the power cords:
 - a. Connect each power cord to the server.
 - b. Connect each power cord to the power source.
20. **Power up the server.**

The installation is complete.

To configure arrays, see the *HPE Smart Array SR Gen10 Configuration Guide* at the **Hewlett Packard Enterprise website.**

Memory options

-  **IMPORTANT:** This server does not support mixing RDIMMs and UDIMMs. Attempting to mix any combination of these DIMMs can cause the server to halt during BIOS initialization. All memory installed in the server must be of the same type.
-

DIMM population information

For specific DIMM population information, see the DIMM population guidelines on the Hewlett Packard Enterprise website (**<http://www.hpe.com/docs/standard-population-rules>**).

Installing a DIMM

Procedure

1. **Power down the server.**
2. Remove all power:
 - a. Disconnect each power cord from the power source.
 - b. Disconnect each power cord from the server.
3. Disconnect all peripheral cables from the server.
4. Do one of the following:

- If the server is in tower mode: **Position the tower server for hardware configuration.**
- If the server is in rack mode: **Remove the server from the rack.**

5. Remove the front bezel.

6. Remove the access panel.

7. If installed, remove the air baffle.

8. Open the DIMM slot latches.

9. Align the notch on the bottom edge of the DIMM with the keyed surface of the DIMM slot, and then fully press the DIMM into the slot until the latches snap back into place.

The DIMM slots are structured to ensure proper installation. If you try to insert a DIMM but it does not fit easily into the slot, you might have positioned it incorrectly. Reverse the orientation of the DIMM and insert it again.

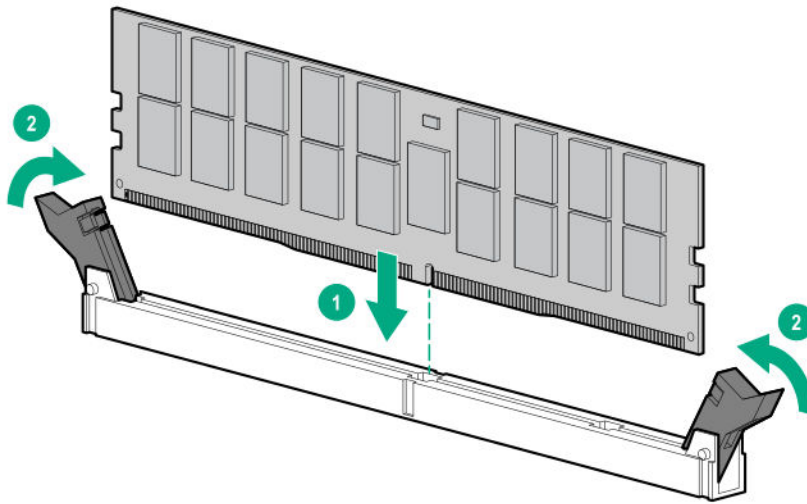

10. If removed, install the air baffle.

11. Install the access panel.

12. Install the front bezel.

13. Connect all peripheral cables to the server.

14. Connect the power cords:

- Connect each power cord to the server.
- Connect each power cord to the power source.

15. Power up the server.

The installation is complete.

After installing the DIMMs, use the **System Utilities > System Configuration > BIOS/Platform > Configuration (RBSU) > Memory Options** to configure the memory settings.

M.2 SSD/dedicated iLO/serial port enablement option

This option provides support for the following:

- M.2 NVMe SSD
- iLO Dedicated Network Port
- Serial port

M.2 SSD/dedicated iLO/serial port enablement option components

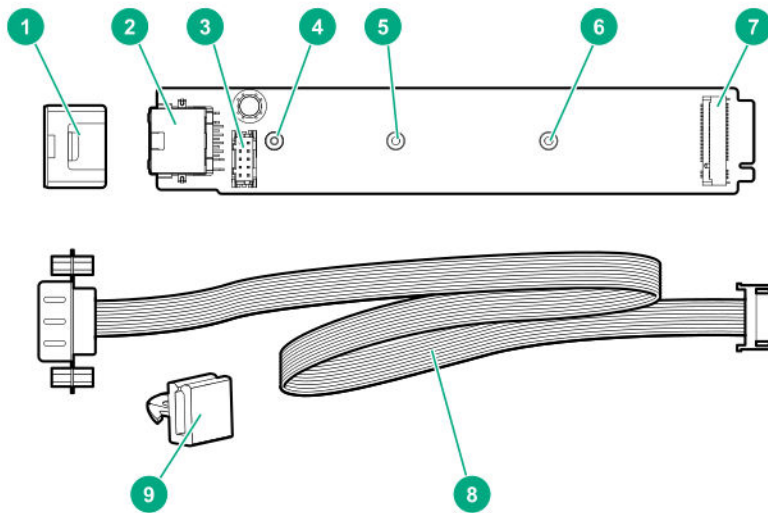

Item	Description
1	Enablement board stabilizer
2	iLO Dedicated Network Port
3	Serial port cable connector
4	M.2 22110 SSD standoff
5	M.2 2280 SSD standoff
6	M.2 2242 SSD standoff
7	M.2 SSD slot
8	Serial port cable
9	Serial port cable clip

Installing the M.2 SSD/dedicated iLO/serial port enablement board

Prerequisites

Before you perform this procedure, make sure that you have the following tools available:

- T-15 Torx screwdriver
- 4.5 mm hex nut screwdriver

Procedure

1. **Power down the server.**
2. Remove all power:
 - a. Disconnect each power cord from the power source.
 - b. Disconnect each power cord from the server.
3. Disconnect all peripheral cables from the server.
4. Do one of the following:
 - If the server is in tower mode: **Position the tower server for hardware configuration.**
 - If the server is in rack mode: **Remove the server from the rack.**
5. **Remove the front bezel.**
6. **Remove the access panel.**
7. If installed, **remove the air baffle.**
8. Remove the Phillips screw and the hex nut.

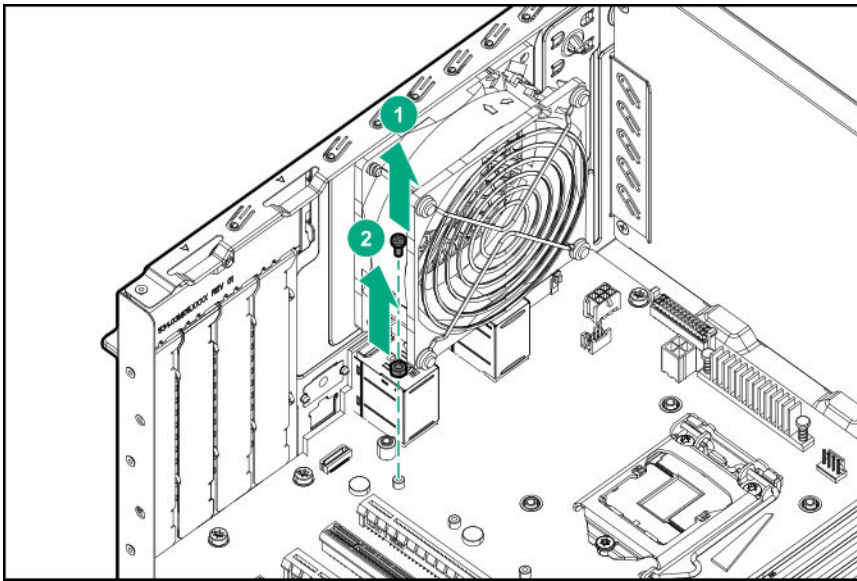

9. Remove the iLO dedicated network port blank.

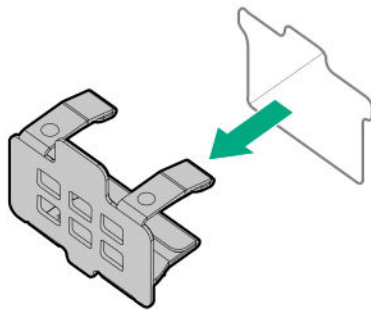

10. Remove the mylar tape.

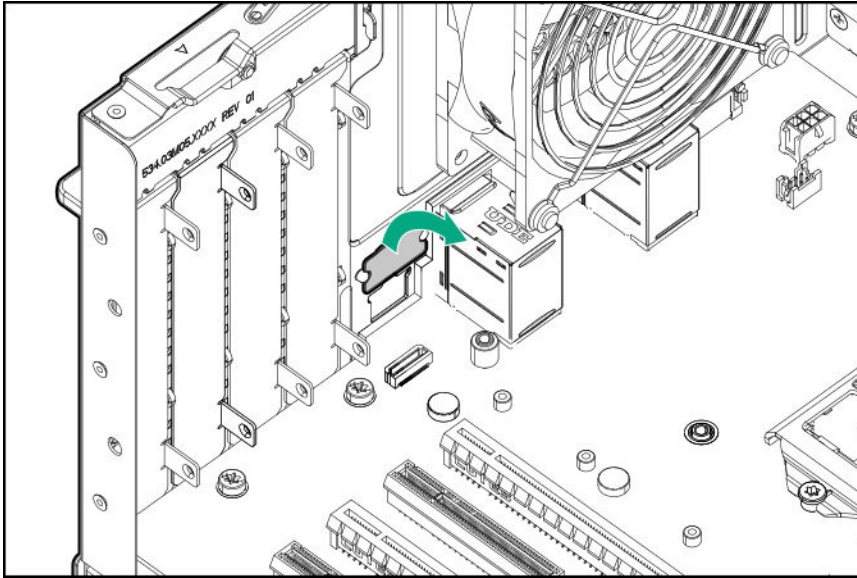

11. Install the M.2 SSD/dedicated iLO/serial port enablement board:
 - a. Insert the enablement board into the M.2 SSD slot at a 45° angle.
 - b. Carefully press the enablement board down to the horizontal position.
 - c. Install the enablement board screw.

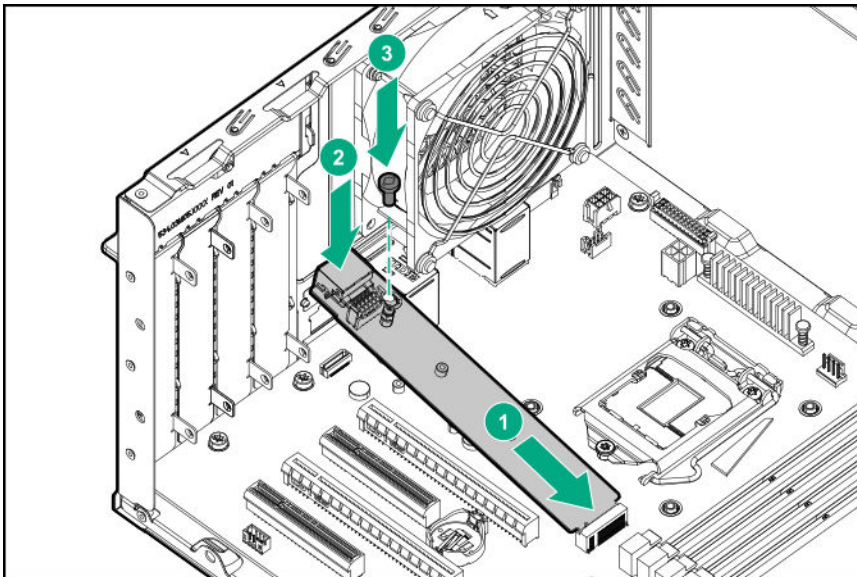

12. Install the enablement board stabilizer.

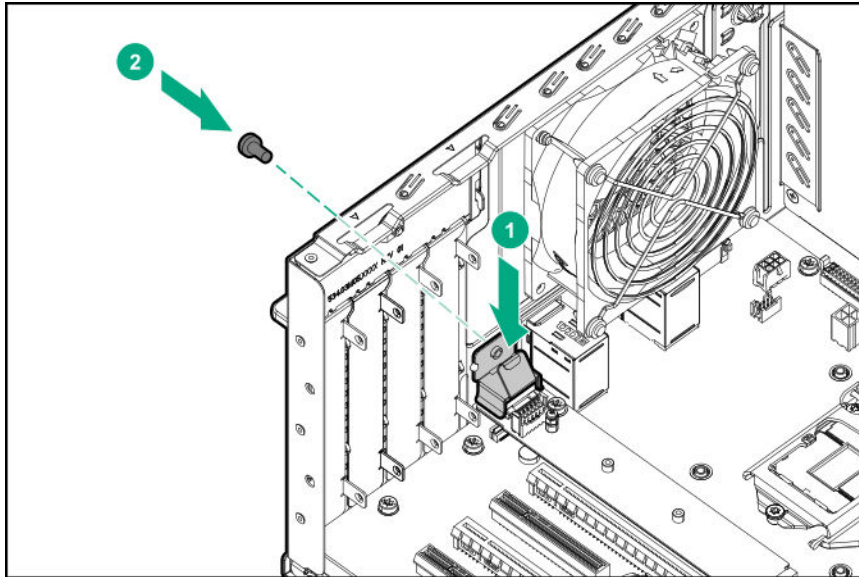

13. If you intend to install an M.2 SSD on the enablement board, **install it now**.
14. If you intend to install the serial port cable, **install it now**.
15. If removed, **install the air baffle**.
16. **Install the access panel**.
17. **Install the front bezel**.
18. Do one of the following:
 - If the server is in tower mode: **Position the tower server for operation**.
 - If the server is in rack mode: **Install the server on the tray**.
19. Connect all peripheral cables to the server.
20. Connect the power cords:
 - a. Connect each power cord to the server.
 - b. Connect each power cord to the power source.
21. **Power up the server**.
22. If you plan to use the iLO Dedicated Network Port, use the iLO web interface to enable this port.
 For more information, see the Enabling the iLO Dedicated Network Port through the iLO web interface section in the iLO user guide on the **Hewlett Packard Enterprise website**.

The installation is complete.

Installing the serial port cable

Prerequisites

Before you perform this procedure, make sure that:

- **The M.2 SSD/dedicated iLO/serial port enablement board is installed.**
- 5 mm hex nut screwdriver is available.

Procedure

1. **Power down the server.**
2. Remove all power:
 - a. Disconnect each power cord from the power source.
 - b. Disconnect each power cord from the server.
3. Disconnect all peripheral cables from the server.
4. Do one of the following:
 - If the server is in tower mode: **Position the tower server for hardware configuration.**
 - If the server is in rack mode: **Remove the server from the rack.**
5. **Remove the front bezel.**
6. **Remove the access panel.**
7. If installed, **remove the air baffle.**
8. Remove the serial port blank.

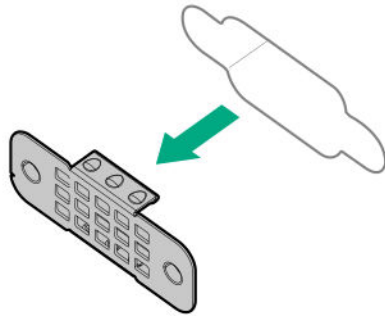

9. Install the serial port.

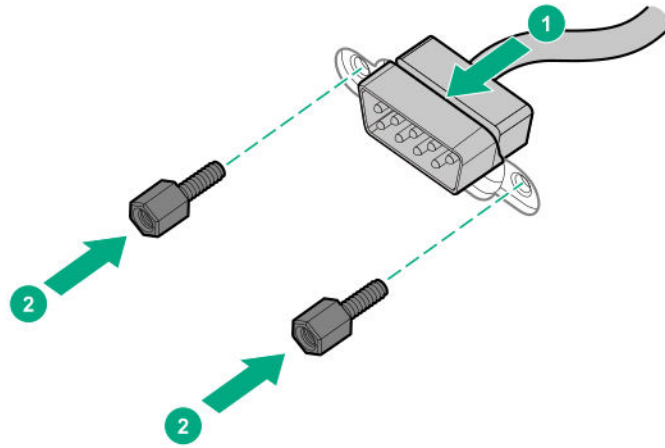

10. Remove the mylar tape.

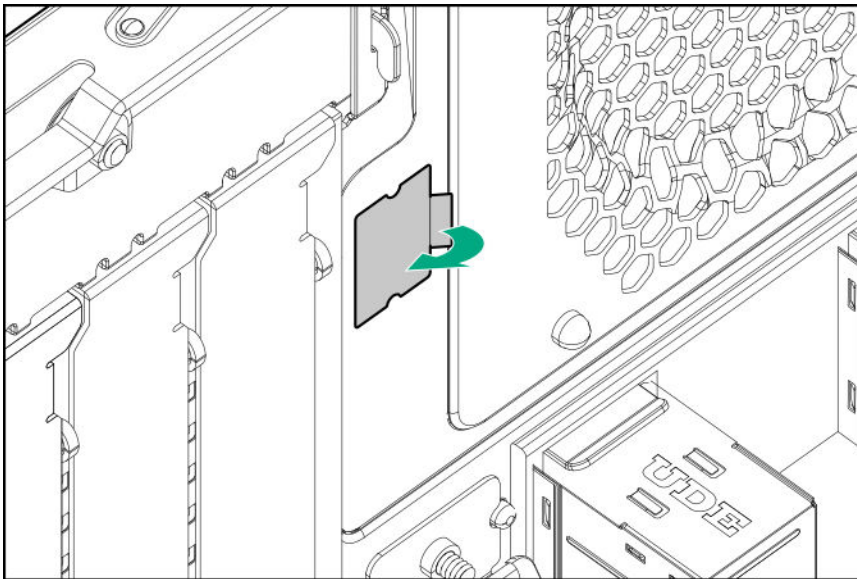

11. Attach the serial port cable clip to the chassis.

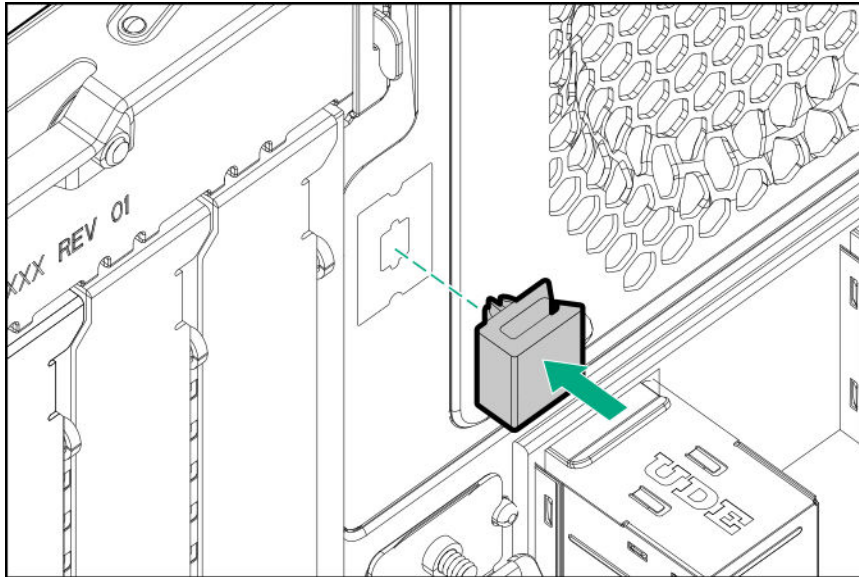

12. Connect the serial port cable to the M.2 SSD/dedicated iLO/serial port enablement board.

To prevent the serial port cable from blocking the system fan airflow, route the cable beneath the fan, and then secure the extra length of the cable in the serial port cable clip.

13. If removed, install the air baffle.

14. Install the access panel.

15. Install the front bezel.

16. Do one of the following:

- If the server is in tower mode: **Position the tower server for operation.**
- If the server is in rack mode: **Install the server on the tray.**

17. Connect all peripheral cables to the server.

18. Connect the power cords:

- a. Connect each power cord to the server.
- b. Connect each power cord to the power source.

19. Power up the server.

The installation is complete.

Enabling the dedicated iLO management module

The onboard NIC 1/shared iLO connector is set as the default system iLO connector. To enable the dedicated iLO management module, use the iLO 5 Configuration Utility accessible within the HPE UEFI System Utilities.

For more information on the UEFI System Utilities, see the UEFI documentation on the Hewlett Packard Enterprise website (<http://www.hpe.com/servers/uefi>).

! **IMPORTANT:** If the iLO configuration settings are reset to the default values, remote access to the machine will be lost. Access the physical machine and repeat the procedure described in this section to re-enable the dedicated iLO management connector.

Procedure

1. During the server startup sequence after installing the module, press **F9** in the POST screen.
The System Utilities screen appears.
2. Select System Configuration | iLO 5 Configuration Utility.
The iLO 5 Configuration Utility screen appears.
3. Select **Network Options**, and then press **Enter**.
The Network Options screen appears.
4. Set the **Network Interface Adapter** field to **ON**, and then press **Enter**.
5. Press **F10** to save your changes.
A message prompt to confirm that the iLO settings reset appears.
6. Press **Enter** to reboot the iLO settings.
7. Press **Esc** until the main menu is displayed.
8. Select **Reboot the System** to exit the utility and resume the boot process.
The IP address of the enabled dedicated iLO connector appears on the POST screen on the subsequent boot-up.
Access the Network Options screen again to view this IP address for later reference.

M.2 SSD option

Use the M.2 slot on the system board or on the optional M.2 SSD/dedicated iLO/serial port enablement board to install an M.2 SSD on the server.

The S100i SR Gen10 SW RAID support requires that the server boot mode be set to UEFI.

Installing an M.2 NVMe SSD on the system board

Prerequisites

Before you perform this procedure, make sure that you have the following tools available:

- T-15 Torx screwdriver
- 4.5 mm hex nut screwdriver
- Phillips No. 1 screwdriver

Procedure

1. **Power down the server.**
2. Remove all power:
 - a. Disconnect each power cord from the power source.
 - b. Disconnect each power cord from the server.
3. Disconnect all peripheral cables from the server.
4. Do one of the following:

- If the server is in tower mode: **Position the tower server for hardware configuration.**
- If the server is in rack mode: **Remove the server from the rack.**

5. Remove the front bezel.

6. Remove the access panel.

7. If installed, remove the air baffle.

8. Remove the alignment screws:

- If installing an M.2 2242 or 2280 SSD, remove both the hex nut and Phillips screw.

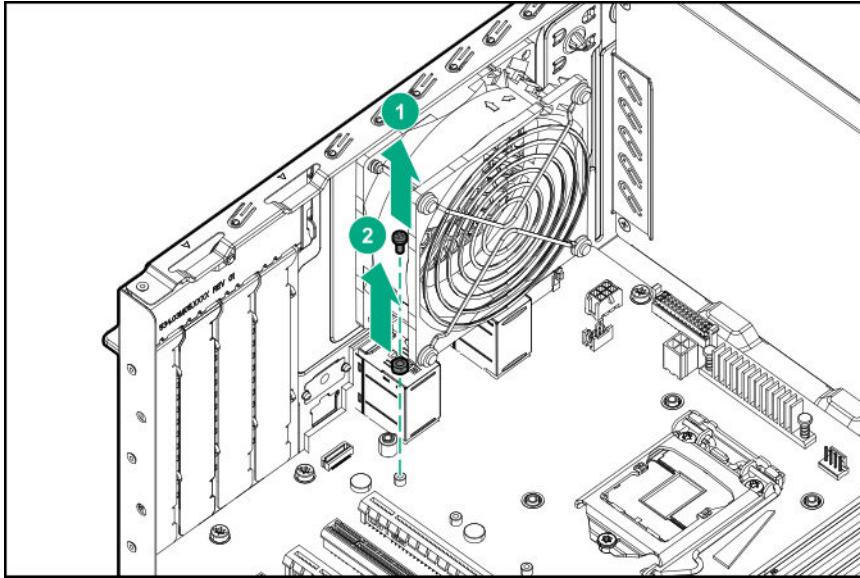

- If installing the M.2 22110, remove only the Phillips screw. Retain the hex nut.

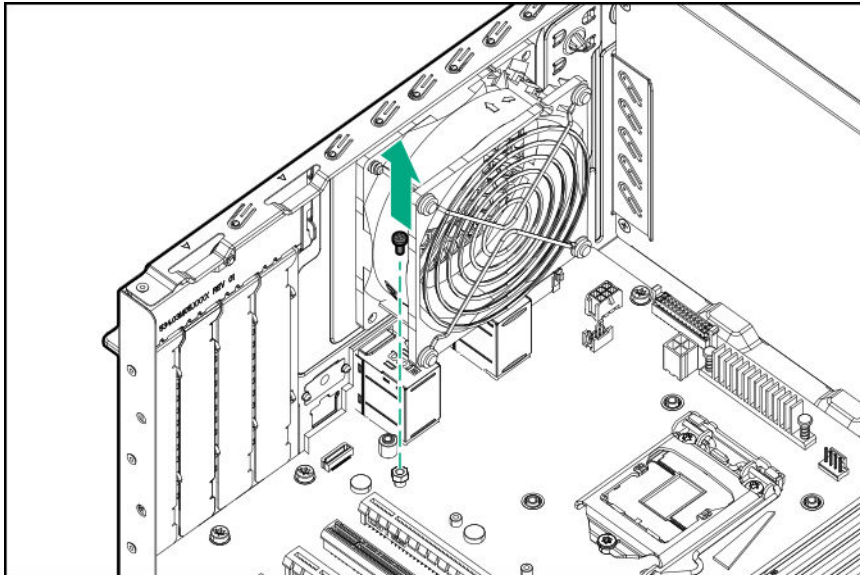

9. Install the hex nut screw on 2242 or 2280 standoff position on the system board.

10. Install the M.2 SSD:

- a. Insert the SSD into the M.2 SSD slot at a 45° angle.
- b. Carefully press the SSD down to the horizontal position.
- c. Secure the SSD to the M.2 SSD enablement board with the removed Phillips screw.

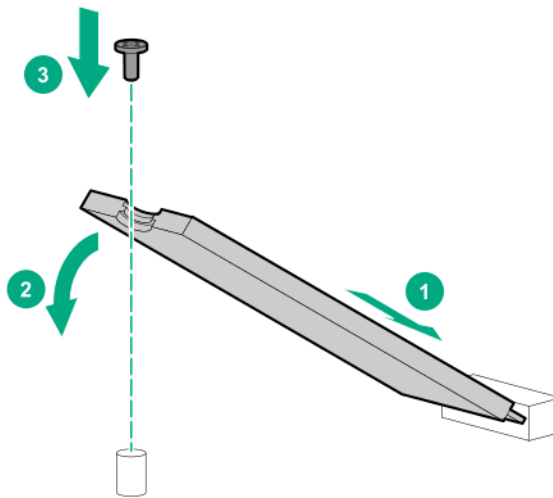

11. If removed, **install the air baffle.**
12. **Install the access panel.**
13. **Install the front bezel.**
14. Do one of the following:
 - If the server is in tower mode: **Position the tower server for operation.**
 - If the server is in rack mode: **Install the server on the tray.**
15. Connect all peripheral cables to the server.
16. Connect the power cords:
 - a. Connect each power cord to the server.
 - b. Connect each power cord to the power source.
17. **Power up the server.**

The installation is complete.

Installing an M.2 NVMe SSD on an M.2 SSD/dedicated iLO/serial port enablement board

Prerequisites

Before you perform this procedure, make sure that you have the following tools available:

- T-15 Torx screwdriver
- 4.5 mm hex nut screwdriver
- Phillips No. 1 screwdriver

Procedure

1. **Power down the server.**
2. Remove all power:
 - a. Disconnect each power cord from the power source.
 - b. Disconnect each power cord from the server.
3. Disconnect all peripheral cables from the server.
4. Do one of the following:
 - If the server is in tower mode: **Position the tower server for hardware configuration.**
 - If the server is in rack mode: **Remove the server from the rack.**
5. **Remove the front bezel.**
6. **Remove the access panel.**
7. If installed, **remove the air baffle.**
8. **Install the M.2 SSD/dedicated iLO/serial port enablement board.**
9. **Identify the appropriate standoff position** and install the hex nut.

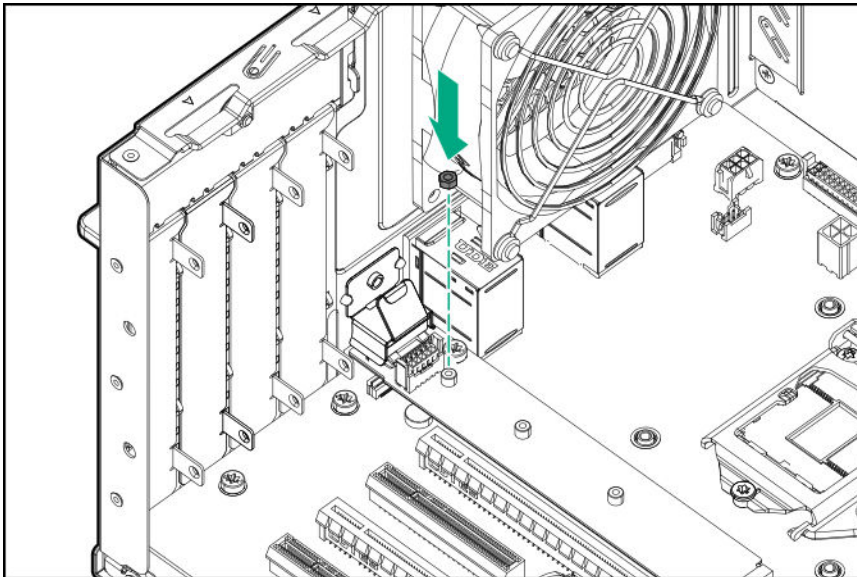

10. Install the M.2 SSD:
 - a. Insert the SSD into the M.2 slot at a 45° angle.
 - b. Carefully press the SSD down to the horizontal position.
 - c. Install the SSD mounting screw.

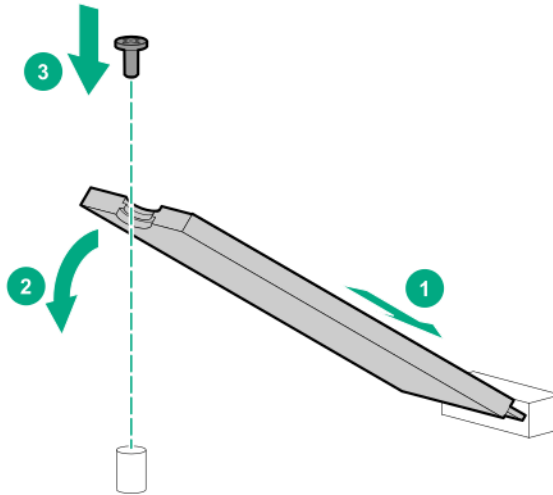

11. If removed, **install the air baffle.**
12. **Install the access panel.**
13. **Install the front bezel.**
14. Do one of the following:
 - If the server is in tower mode: **Position the tower server for operation.**
 - If the server is in rack mode: **Install the server on the tray.**
15. Connect all peripheral cables to the server.
16. Connect the power cords:
 - a. Connect each power cord to the server.
 - b. Connect each power cord to the power source.
17. **Power up the server.**

The installation is complete.

To configure the M.2 SSD, see the *HPE Smart Array SR Gen10 Configuration Guide* at the [Hewlett Packard Enterprise website](#).

Storage controller options

The server supports the following storage controllers:

- For SATA drives only – Embedded HPE Smart Array S100i SR Gen10 Controller
- For SAS and SATA drives – Type-p standup plug-in Smart Array controller

The Smart Array controller can be installed in PCI expansion slots. For more information on the PCI slot specifications, see [PCI expansion slot definitions](#).

Installing a Smart Array standup storage controller

Prerequisites

Before you perform this procedure, make sure that you have the following items available:

- Smart Array standup controller option kit

This kit includes the:

- Smart Array storage controller
 - Controller backup power cable
- If you are installing a Smart Array type-p Gen10 controller, **an energy pack option is required.**
 - T-15 Torx screwdriver

Before you perform this procedure, perform the following steps:

1. Back up data on the system.
2. Close all applications.
3. **Update the server firmware if it is not the latest revision.**
4. Do one of the following:
 - If the new Smart Array is the new boot device, install the device drivers.
 - If the new Smart Array is not the new boot device, go to the next step.
5. Ensure that users are logged off and that all tasks are completed on the server.

⚠ CAUTION: In systems that use external data storage, be sure that the server is the first unit to be powered down and the last to be powered back up. Taking this precaution ensures that the system does not erroneously mark the drives as failed when the server is powered up.

Procedure

1. **Power down the server.**
2. Remove all power:
 - a. Disconnect each power cord from the power source.
 - b. Disconnect each power cord from the server.
3. Disconnect all peripheral cables from the server.
4. Do one of the following:
 - If the server is in tower mode: **Position the tower server for hardware configuration.**
 - If the server is in rack mode: **Remove the server from the rack.**
5. **Remove the front bezel.**
6. **Remove the access panel.**

7. If installed, **remove the air baffle.**
8. **Remove the PCI slot blank retainer.**
9. **Remove the PCI slot blank.**
10. Install the controller into a PCI slot.

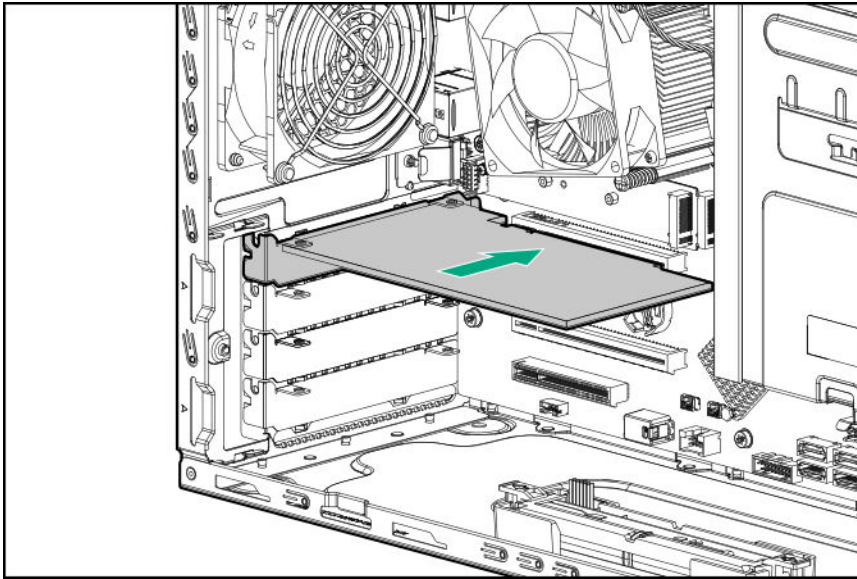

11. Install the PCI slot blank retainer.

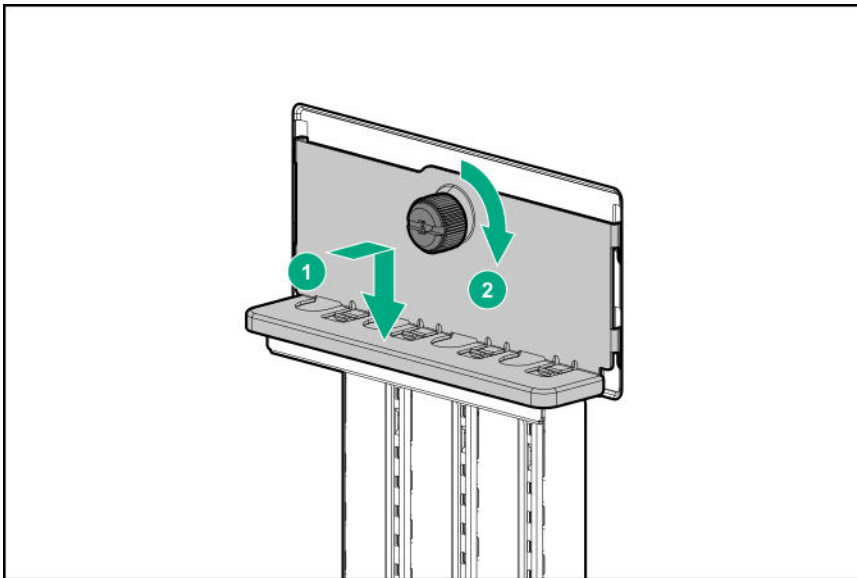

12. **Cable the controller.**
13. To enable HPE Smart Array SR SmartCache in a Smart Array P-class type-p Gen10 controller, **install an energy pack.**

SmartCache and CacheCade enable solid-state drives to be used as caching devices for hard drive media. These features accelerate access to frequently used data by caching hot data from the hard drives onto the solid-state drives.
14. If removed, **install the air baffle.**
15. **Install the access panel.**

16. Install the front bezel.

17. Do one of the following:

- If the server is in tower mode: **Position the tower server for operation.**
- If the server is in rack mode: **Install the server on the tray.**

18. Connect all peripheral cables to the server.

19. Connect the power cords:

- a. Connect each power cord to the server.
- b. Connect each power cord to the power source.

20. Configure the controller.

The installation is complete.

Configuring an HPE Smart Array Gen10 controller

Procedure

1. Power up the server.

2. If you are running the server in UEFI Boot Mode, select the boot options.

3. Update the drive firmware if it is not the latest revision.

4. (Optional) If running the server in Legacy Boot Mode, set the controller as the boot controller.

5. (Optional) If running the server in Legacy Boot Mode, change the controller boot order.

6. If the new controller is not the new boot device, install the device drivers.

7. If the controller firmware is not the latest version, use SPP to update it.

8. Use UEFI System Utilities or HPE Smart Storage Administrator (HPE SSA) to create arrays and logical drives.

See the following resources for more information:

- SPP – See the product documentation in the information library:

<http://www.hpe.com/info/spp/docs>

- UEFI System Utilities or HPE Smart Storage Administrator – See the *HPE Smart Array SR Gen10 Configuration Guide* in the information library:

<http://www.hpe.com/info/smartstorage-docs>

Energy pack options

Hewlett Packard Enterprise offers two centralized backup power source options to back up write cache content on P-class Smart Array controllers in case of an unplanned server power outage.

- **HPE Smart Storage Battery**
- **HPE Smart Storage Hybrid Capacitor**

! **IMPORTANT:** The HPE Smart Storage Hybrid Capacitor is only supported on Gen10 and later servers that support the 96W HPE Smart Storage Battery.

One energy pack option can support multiple devices. An energy pack option is required for P-class Smart Array controllers. Once installed, the status of the energy pack displays in HPE iLO. For more information, see the HPE iLO user guide on the Hewlett Packard Enterprise website (<http://www.hpe.com/support/ilo-docs>).

HPE Smart Storage Battery

The HPE Smart Storage Battery supports the following devices:

HPE Smart Array SR controllers

A single 96W battery can support up to 24 devices.

After the battery is installed, it might take up to two hours to charge. Controller features requiring backup power are not re-enabled until the battery is capable of supporting the backup power.

This server supports the 96W HPE Smart Storage Battery with the 145mm cable.

HPE Smart Storage Hybrid Capacitor

The HPE Smart Storage Hybrid Capacitor supports the following devices:

HPE Smart Array SR controllers

The capacitor pack can support up to three devices.

This server supports the HPE Smart Storage Hybrid Capacitor with the 145mm cable.

Before installing the HPE Smart Storage Hybrid Capacitor, verify that the system BIOS meets the minimum firmware requirements to support the capacitor pack.

! **IMPORTANT:** If the system BIOS or controller firmware is older than the minimum recommended firmware versions, the capacitor pack will only support one device.

The capacitor pack is fully charged after the system boots.

Minimum firmware versions

Product	Minimum firmware version
HPE ProLiant ML30 Gen10 Server system ROM	2.00
HPE Smart Array SR controllers	1.90

Installing an energy pack

Prerequisites

Before you perform this procedure:

- **Make sure that a Smart Array P-class type-p Gen10 controller is installed.**
- Make sure that you have the following items available:

- Storage controller backup power cable (ships with the storage controller)
- Energy pack option
- If you are installing the HPE Smart Storage Hybrid Capacitor, **verify that the system BIOS meets the minimum firmware requirements.**

Procedure

1. **Power down the server.**
2. Remove all power:
 - a. Disconnect each power cord from the power source.
 - b. Disconnect each power cord from the server.
3. Disconnect all peripheral cables from the server.
4. Do one of the following:
 - If the server is in tower mode: **Position the tower server for hardware configuration.**
 - If the server is in rack mode: **Remove the server from the rack.**
5. **Remove the front bezel.**
6. **Remove the access panel.**
7. If installed, **remove the air baffle.**
8. Remove the black tapes from the chassis.

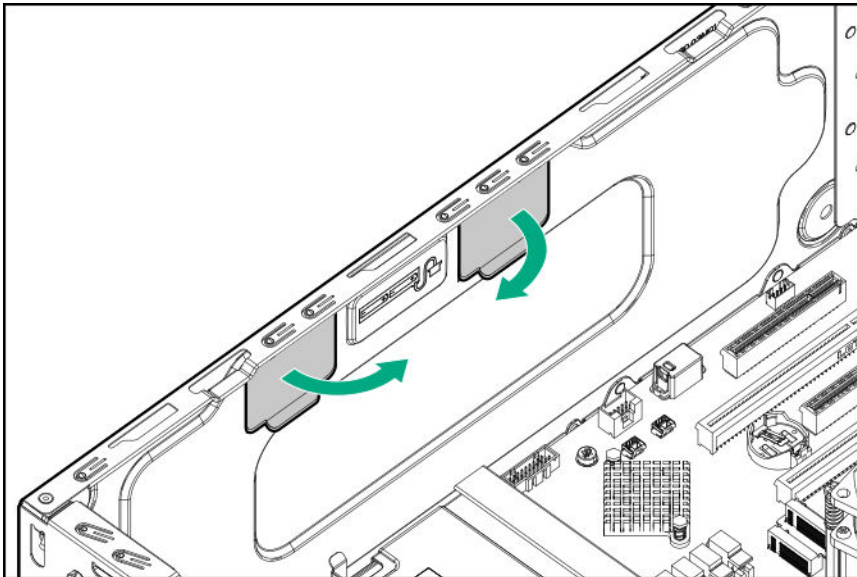

9. Install the energy pack holders.

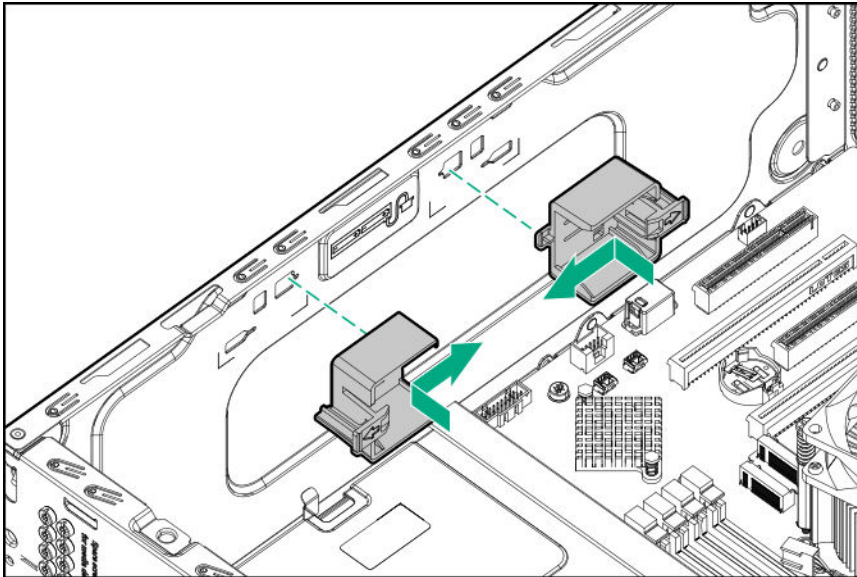

- 10.** Secure the energy pack in the holders:
 - a.** Position one end of the energy pack into the holder.
 - b.** Press and hold the release latch on the holder.
 - c.** Position the other end of the energy pack into the holder.
 - d.** Connect the energy pack cable.

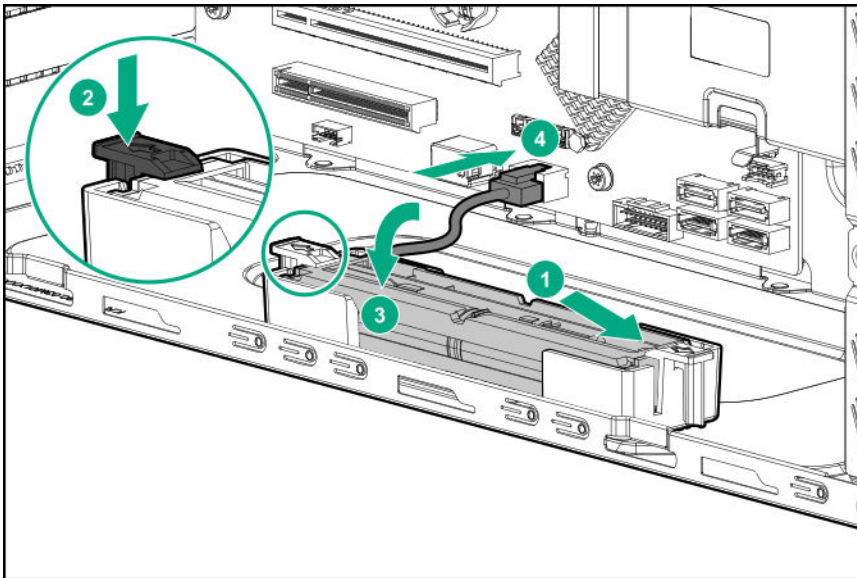

- 11.** **Connect the storage controller backup power cable.**
- 12.** If removed, **install the air baffle.**
- 13.** **Install the access panel.**
- 14.** **Install the front bezel.**
- 15.** Do one of the following:

- If the server is in tower mode: **Position the tower server for operation.**
- If the server is in rack mode: **Install the server on the tray.**

16. Connect all peripheral cables to the server.

17. Connect the power cords:

- a. Connect each power cord to the server.
- b. Connect each power cord to the power source.

18. Power up the server.

The installation is complete.

Expansion board options

The server has four PCI3 expansion slots that support different form factor expansion boards. For more information on the PCI slot specifications, see **PCI expansion slot definitions.**

Expansion board thermal requirement

The PCI fan option is required to meet the system thermal requirement when any of the following expansion board options are installed:

- Type-p Smart Array controllers
- High-performance NIC controllers
- 10 GB Ethernet adapters
- GPUs
- M.2 SSDs
- Third-party expansion boards

Installing an expansion board



CAUTION: To prevent improper cooling and thermal damage, do not operate the server unless all PCI slots have either an expansion slot cover or an expansion board installed.

Prerequisites

Before you perform this procedure:

- Check if the expansion board option requires the PCI fan option, see **Expansion board thermal requirement.**
- Make sure that you have a T-15 Torx screwdriver available.

Procedure

- 1. Power down the server.**
- 2.** Remove all power:

- a. Disconnect each power cord from the power source.
 - b. Disconnect each power cord from the server.
3. Disconnect all peripheral cables from the server.
4. Do one of the following:
 - If the server is in tower mode: **Position the tower server for hardware configuration.**
 - If the server is in rack mode: **Remove the server from the rack.**
5. **Remove the front bezel.**
6. **Remove the access panel.**
7. If installed, **remove the air baffle.**
8. **Remove the PCI slot blank retainer.**
9. **Remove the PCI slot blank.**
10. Install the expansion board. Make sure that the board is firmly seated in the slot.

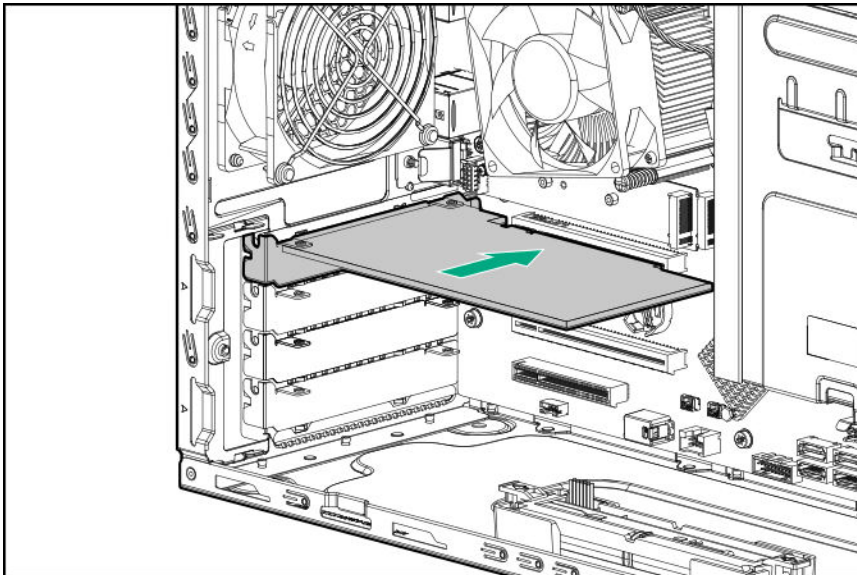

11. Connect all necessary internal cabling to the expansion board.
For more information on these cabling requirements, see the documentation that ships with the option.
12. Install the PCI slot blank retainer.

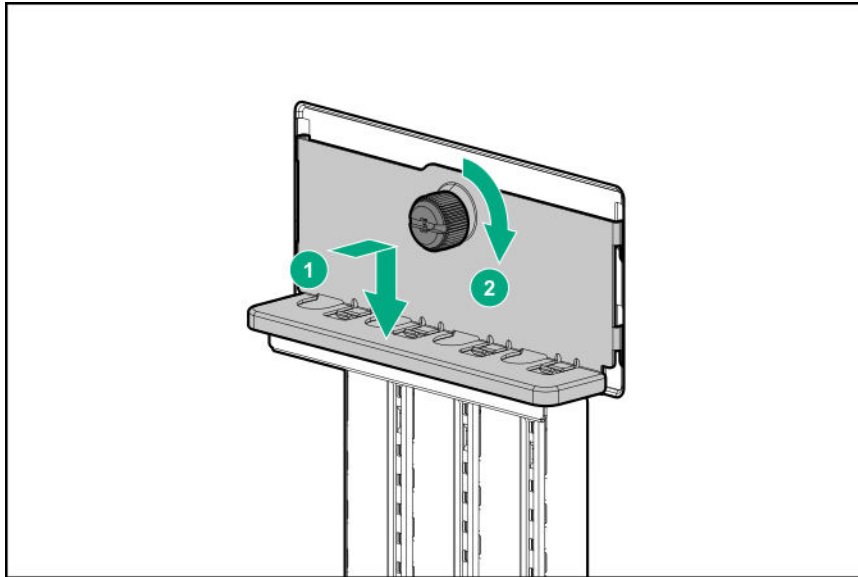

13. If removed, **install the air baffle.**
14. **Install the access panel.**
15. **Install the front bezel.**
16. Do one of the following:
 - If the server is in tower mode: **Position the tower server for operation.**
 - If the server is in rack mode: **Install the server on the tray.**
17. Connect all necessary external cabling to the expansion board.
For more information on these cabling requirements, see the documentation that ships with the option.
18. Connect all peripheral cables to the server.
19. Connect the power cords:
 - a. Connect each power cord to the server.
 - b. Connect each power cord to the power source.
20. **Power up the server.**

The installation is complete.

Internal USB device option

The server provides one internal USB 2.0 port and one USB 3.0 port. You can use these two ports to install internal USB devices such as USB flash media devices. These devices are rarely removed and are used for booting up from flash solutions or for data backup/redundancy.

Installing an internal USB device

Procedure

1. **Power down the server.**
2. Remove all power:
 - a. Disconnect each power cord from the power source.
 - b. Disconnect each power cord from the server.
3. Disconnect all peripheral cables from the server.
4. Do one of the following:
 - If the server is in tower mode: **Position the tower server for hardware configuration.**
 - If the server is in rack mode: **Remove the server from the rack.**
5. **Remove the front bezel.**
6. **Remove the access panel.**
7. If installed, **remove the air baffle.**
8. **Locate the internal USB connector.**
9. Plug in the USB device into the internal USB port.

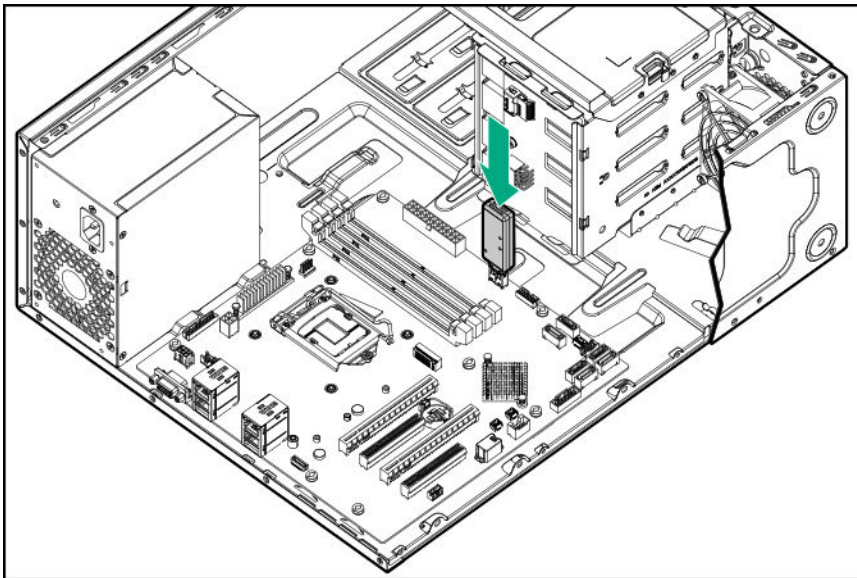

10. If removed, **install the air baffle.**
11. **Install the access panel.**
12. **Install the front bezel.**
13. Do one of the following:

- If the server is in tower mode: **Position the tower server for operation.**
- If the server is in rack mode: **Install the server on the tray.**

14. Connect all peripheral cables to the server.

15. Connect the power cords:

- a. Connect each power cord to the server.
- b. Connect each power cord to the power source.

16. Power up the server.

The installation is complete.

HPE Trusted Platform Module 2.0 Gen10 option

Overview

Use these instructions to install and enable an HPE TPM 2.0 Gen10 Kit in a supported server. This option is not supported on Gen9 and earlier servers.

This procedure includes three sections:

- 1.** Installing the Trusted Platform Module board.
- 2.** Enabling the Trusted Platform Module.
- 3.** Retaining the recovery key/password.

HPE TPM 2.0 installation is supported with specific operating system support such as Microsoft® Windows Server® 2012 R2 and later. For more information about operating system support, see the product QuickSpecs on the Hewlett Packard Enterprise website (<http://www.hpe.com/info/qs>). For more information about Microsoft® Windows® BitLocker Drive Encryption feature, see the Microsoft website (<http://www.microsoft.com>).

⚠ CAUTION: If the TPM is removed from the original server and powered up on a different server, data stored in the TPM including keys will be erased.

❗ IMPORTANT: In UEFI Boot Mode, the HPE TPM 2.0 Gen10 Kit can be configured to operate as TPM 2.0 (default) or TPM 1.2 on a supported server. In Legacy Boot Mode, the configuration can be changed between TPM 1.2 and TPM 2.0, but only TPM 1.2 operation is supported.

HPE Trusted Platform Module 2.0 Guidelines

⚠ CAUTION: Always observe the guidelines in this document. Failure to follow these guidelines can cause hardware damage or halt data access.

Hewlett Packard Enterprise SPECIAL REMINDER: Before enabling TPM functionality on this system, you must ensure that your intended use of TPM complies with relevant local laws, regulations and policies, and approvals or licenses must be obtained if applicable.

For any compliance issues arising from your operation/usage of TPM which violates the above mentioned requirement, you shall bear all the liabilities wholly and solely. Hewlett Packard Enterprise will not be responsible for any related liabilities.

慧与特别提醒：在您启用系统中的TPM功能前，请务必确认您对TPM的使用遵守当地相关法律、法规及政策，并已事先获得所需的一切批准及许可（如适用），因您未获得相应的操作/使用许可而导致的违规问题，皆由您自行承担全部责任，与慧与无涉。

When installing or replacing a TPM, observe the following guidelines:

- Do not remove an installed TPM. Once installed, the TPM becomes a permanent part of the system board.
- When installing or replacing hardware, Hewlett Packard Enterprise service providers cannot enable the TPM or the encryption technology. For security reasons, only the customer can enable these features.
- When returning a system board for service replacement, do not remove the TPM from the system board. When requested, Hewlett Packard Enterprise Service provides a TPM with the spare system board.
- Any attempt to remove the cover of an installed TPM from the system board can damage the TPM cover, the TPM, and the system board.
- If the TPM is removed from the original server and powered up on a different server, all data stored in the TPM including keys will be erased.
- When using BitLocker, always retain the recovery key/password. The recovery key/password is required to complete Recovery Mode after BitLocker detects a possible compromise of system integrity.
- Hewlett Packard Enterprise is not liable for blocked data access caused by improper TPM use. For operating instructions, see the TPM documentation or the encryption technology feature documentation provided by the operating system.

Installing and enabling the HPE TPM 2.0 Gen10 Kit

Installing the Trusted Platform Module board

Preparing the server for installation

Procedure

1. Observe the following warnings:



WARNING: The front panel Power On/Standby button does not shut off system power. Portions of the power supply and some internal circuitry remain active until AC power is removed.

To reduce the risk of personal injury, electric shock, or damage to the equipment, remove power from the server:

For rack and tower servers, remove the power cord.

For server blades and compute modules, remove the server blade or compute module from the enclosure.



WARNING: To reduce the risk of personal injury from hot surfaces, allow the drives and the internal system components to cool before touching them.

2. Update the system ROM.

Locate and download the latest ROM version from the [**Hewlett Packard Enterprise Support Center website**](#). Follow the instructions on the website to update the system ROM.

- 3. Power down the server.**
- 4.** Remove all power:
 - a.** Disconnect each power cord from the power source.
 - b.** Disconnect each power cord from the server.
- 5.** Disconnect all peripheral cables from the server.
- 6.** Do one of the following:
 - If the server is in tower mode: **Position the tower server for hardware configuration.**
 - If the server is in rack mode: **Remove the server from the rack.**
- 7. Remove the front bezel.**
- 8. Remove the access panel.**
- 9.** If installed, **remove the air baffle.**
- 10.** Remove any components or cables that may prevent access to the TPM connector.
- 11.** Proceed to **Installing the TPM board and cover.**

Installing the TPM board and cover

Procedure

- 1.** Observe the following alerts:

 **CAUTION:** If the TPM is removed from the original server and powered up on a different server, data stored in the TPM including keys will be erased.

 **CAUTION:** The TPM is keyed to install only in the orientation shown. Any attempt to install the TPM in a different orientation might result in damage to the TPM or system board.

- 2.** Align the TPM board with the key on the connector, and then install the TPM board. To seat the board, press the TPM board firmly into the connector. To locate the TPM connector on the system board, see the server label on the access panel.

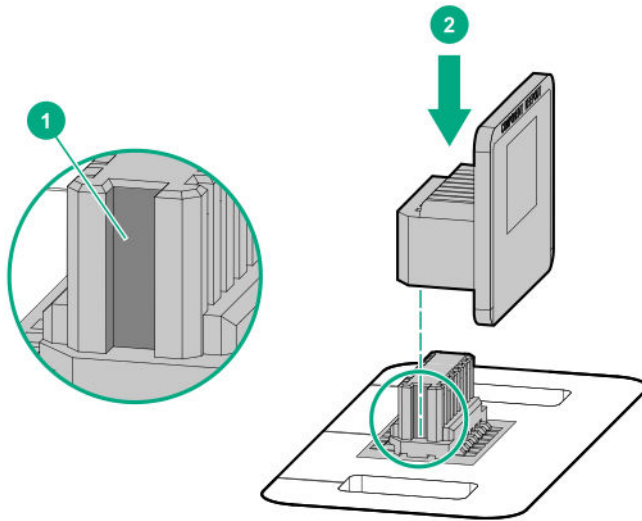

3. Install the TPM cover:

- a.** Line up the tabs on the cover with the openings on either side of the TPM connector.
- b.** To snap the cover into place, firmly press straight down on the middle of the cover.

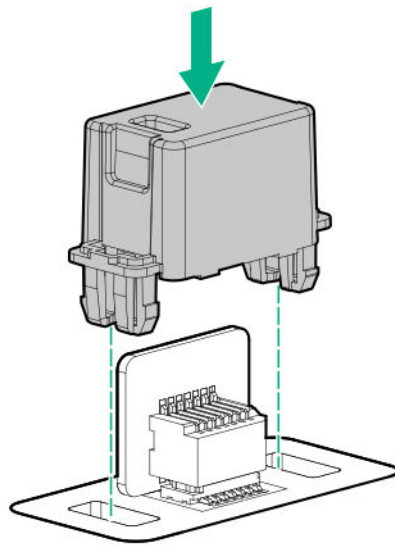

4. Proceed to **Preparing the server for operation**.

Preparing the server for operation

Procedure

- 1.** Install any options or cables previously removed to access the TPM connector.
- 2.** If removed, **install the air baffle**.
- 3.** **Install the access panel**.
- 4.** **Install the front bezel**.

5. Do one of the following:
 - If the server is in tower mode: **Position the tower server for operation.**
 - If the server is in rack mode: **Install the server on the tray.**
6. Connect all peripheral cables to the server.
7. Connect the power cords:
 - a. Connect each power cord to the server.
 - b. Connect each power cord to the power source.
8. **Power up the server.**

The installation is complete.

Enabling the Trusted Platform Module

When enabling the Trusted Platform module, observe the following guidelines:

- By default, the Trusted Platform Module is enabled as TPM 2.0 when the server is powered on after installing it.
- In UEFI Boot Mode, the Trusted Platform Module can be configured to operate as TPM 2.0 (default) or TPM 1.2.
- In Legacy Boot Mode, the Trusted Platform Module configuration can be changed between TPM 1.2 and TPM 2.0 (default), but only TPM 1.2 operation is supported.

Enabling the Trusted Platform Module as TPM 2.0

Procedure

1. During the server startup sequence, press the **F9** key to access **System Utilities**.
2. From the System Utilities screen, select **System Configuration > BIOS/Platform Configuration (RBSU) > Server Security > Trusted Platform Module options**.
3. Verify the following:
 - "Current TPM Type" is set to **TPM 2.0**.
 - "Current TPM State" is set to **Present and Enabled**.
 - "TPM Visibility" is set to **Visible**.
4. If changes were made in the previous step, press the **F10** key to save your selection.
5. If F10 was pressed in the previous step, do one of the following:
 - If in graphical mode, click **Yes**.
 - If in text mode, press the **Y** key.
6. Press the **ESC** key to exit System Utilities.
7. If changes were made and saved, the server prompts for reboot request. Press the **Enter** key to confirm reboot.

If the following actions were performed, the server reboots a second time without user input. During this reboot, the TPM setting becomes effective.

- Changing from TPM 1.2 and TPM 2.0
 - Changing TPM bus from FIFO to CRB
 - Enabling or disabling TPM
 - Clearing the TPM
8. Enable TPM functionality in the OS, such as Microsoft Windows BitLocker or measured boot.
- For more information, see the [Microsoft website](#).

Enabling the Trusted Platform Module as TPM 1.2

Procedure

1. During the server startup sequence, press the **F9** key to access **System Utilities**.
 2. From the System Utilities screen select **System Configuration > BIOS/Platform Configuration (RBSU) > Server Security > Trusted Platform Module options**.
 3. Change the "TPM Mode Switch Operation" to **TPM 1.2**.
 4. Verify "TPM Visibility" is **Visible**.
 5. Press the **F10** key to save your selection.
 6. When prompted to save the change in System Utilities, do one of the following:
 - If in graphical mode, click **Yes**.
 - If in text mode, press the **Y** key.
 7. Press the **ESC** key to exit System Utilities.

The server reboots a second time without user input. During this reboot, the TPM setting becomes effective.
 8. Enable TPM functionality in the OS, such as Microsoft Windows BitLocker or measured boot.
- For more information, see the [Microsoft website](#).

Retaining the BitLocker recovery key/password

The recovery key/password is generated during BitLocker setup, and can be saved and printed after BitLocker is enabled. When using BitLocker, always retain the recovery key/password. The recovery key/password is required to enter Recovery Mode after BitLocker detects a possible compromise of system integrity.

To help ensure maximum security, observe the following guidelines when retaining the recovery key/password:

- Always store the recovery key/password in multiple locations.
- Always store copies of the recovery key/password away from the server.
- Do not save the recovery key/password on the encrypted hard drive.

Cabling

Cabling guidelines

The cable colors in the cabling diagrams used in this chapter are for illustration purposes only. Most of the server cables are black.

Observe the following guidelines when working with server cables.

Before connecting cables

- Note the port labels on the PCA components. Not all of these components are used by all servers:
 - System board ports
 - Drive and power supply backplane ports
 - Expansion board ports (controllers, adapters, expanders, risers, and similar boards)
- Note the label near each cable connector. This label indicates the destination port for the cable connector.
- Some data cables are pre-bent. Do not unbend or manipulate the cables.
- To prevent mechanical damage or depositing oil that is present on your hands, and other contamination, do not touch the ends of the connectors.

When connecting cables

- Before connecting a cable to a port, lay the cable in place to verify the length of the cable.
- Use the internal cable management features to properly route and secure the cables.
- When routing cables, be sure that the cables are not in a position where they can be pinched or crimped.
- Avoid tight bend radii to prevent damaging the internal wires of a power cord or a server cable. Never bend power cords and server cables tight enough to cause a crease in the sheathing.
- Make sure that the excess length of cables are properly secured to avoid excess bends, interference issues, and airflow restriction.
- To prevent component damage and potential signal interference, make sure that all cables are in their appropriate routing position before installing a new component and before closing up the server after hardware installation/maintenance.

When disconnecting cables

- Grip the body of the cable connector. Do not pull on the cable itself because this action can damage the internal wires of the cable or the pins on the port.
- If a cable does not disconnect easily, check for any release latch that must be pressed to disconnect the cable.

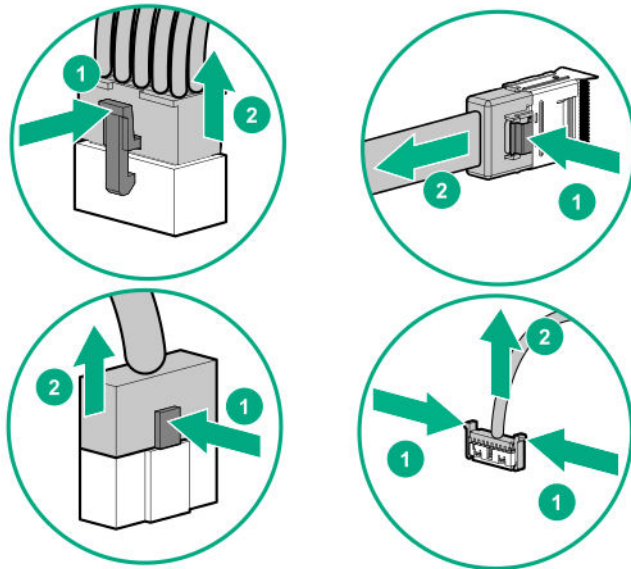

- Remove cables that are no longer being used. Retaining them inside the server can restrict airflow. If you intend to use the removed cables later, label and store them for future use.

Storage cabling

LFF non-hot-plug drive cabling from the media bay

LFF non-hot-plug drive cabling with standard power supply

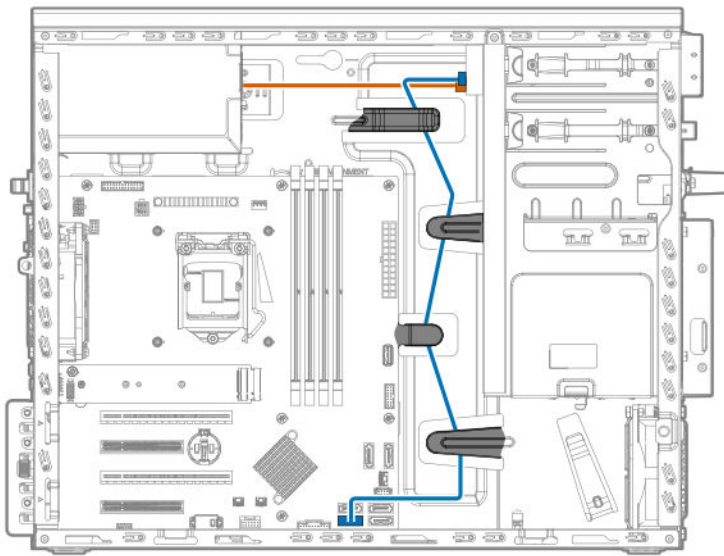

Cable color	Description
Orange	Power supply cable
Blue	SATA port 6 cable

LFF non-hot-plug drive cabling with Flexible Slot power supply

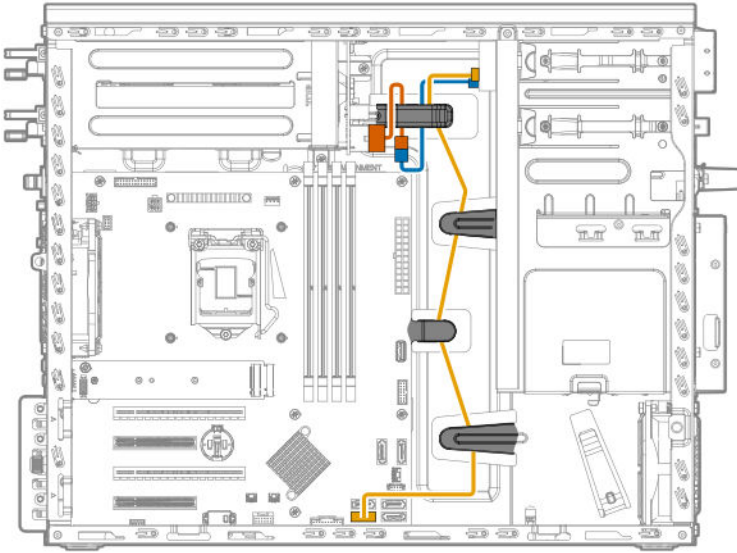

Cable color	Description
Orange	Power supply cable
Blue	Drive power cable
Gold	SATA port 6 cable

LFF non-hot-plug drive cabling from the drive cage

LFF non-hot-plug drive cabling with standard power supply

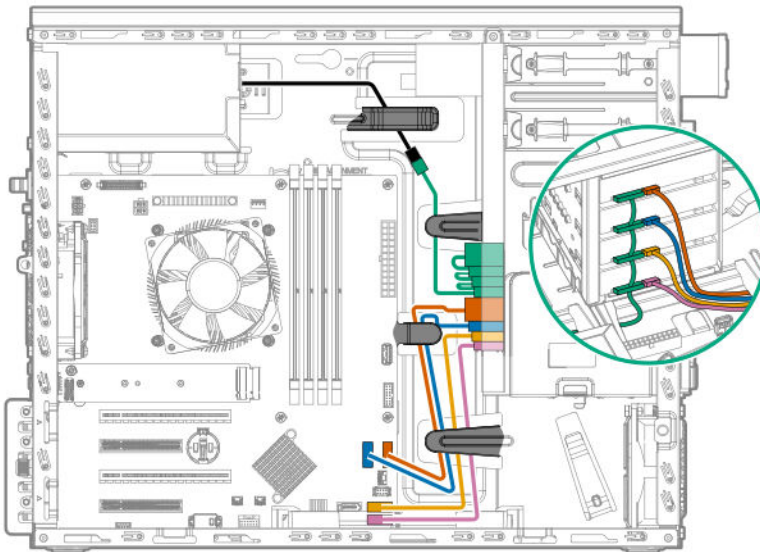

Cable color	Description
Orange	SATA port 2 cable
Blue	SATA port 1 cable

Table Continued

Cable color	Description
Gold	SATA port 3 cable
Pink	SATA port 4 cable
Green	Drive power cable
Black	Power supply cable

LFF non-hot-plug drive cabling with Flexible Slot power supply

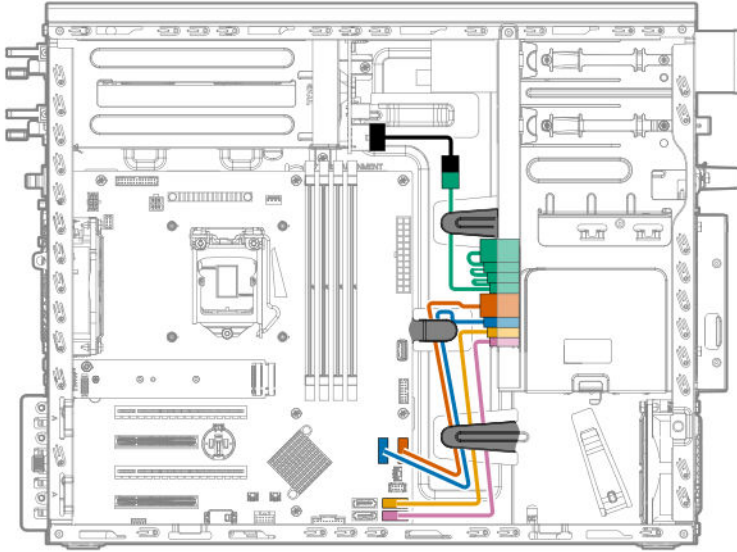

Cable color	Description
Orange	SATA port 2 cable
Blue	SATA port 1 cable
Gold	SATA port 3 cable
Pink	SATA port 4 cable
Green	Drive power cable
Black	Power supply cable

LFF hot-plug drive cabling

LFF hot-plug drive cabling with standard power supply

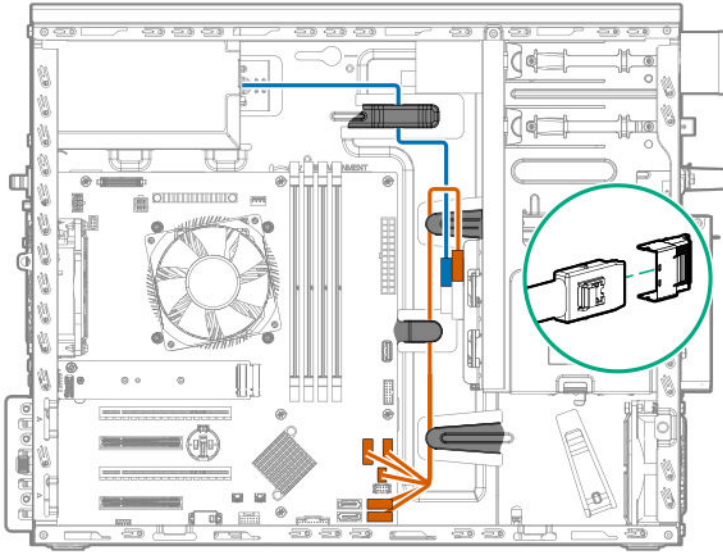

Cable color	Description
Orange	Mini-SAS cable with sideband connector
Blue	Drive power cable

LFF hot-plug drive cabling with Flexible Slot power supply

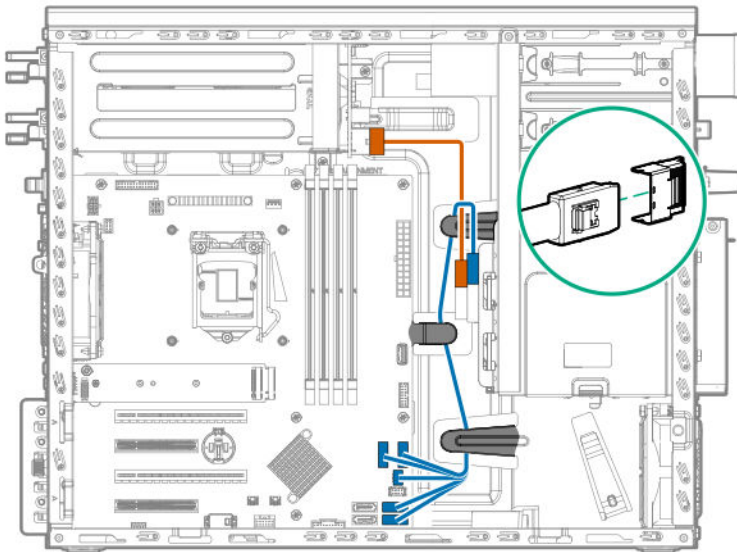

Cable color	Description
Orange	Drive power cable
Blue	Mini-SAS cable with sideband connector

LFF hot-plug drive cabling for controller with standard power supply

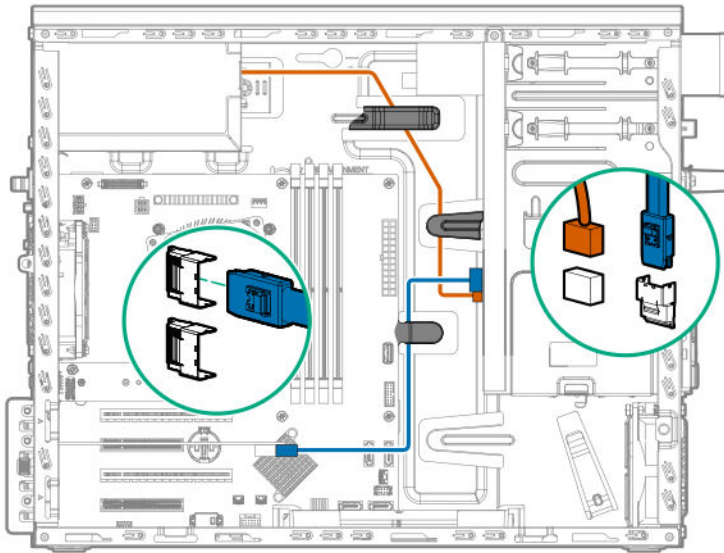

Cable color	Description
Orange	Drive power cable
Blue	Mini-SAS cable to controller port 1

LFF hot-plug drive cabling for controller with Flexible Slot power supply

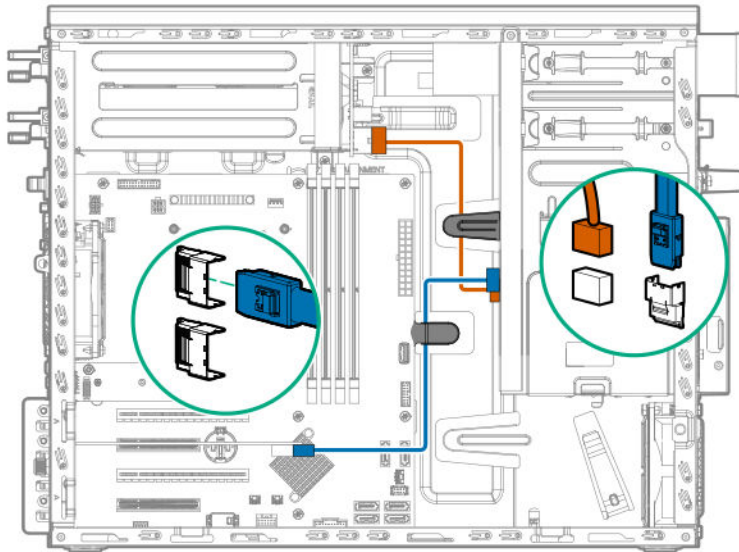

Cable color	Description
Orange	Drive power cable
Blue	Mini-SAS cable to controller port 1

SFF hot-plug drive cabling

SFF hot-plug drive cabling with standard power supply

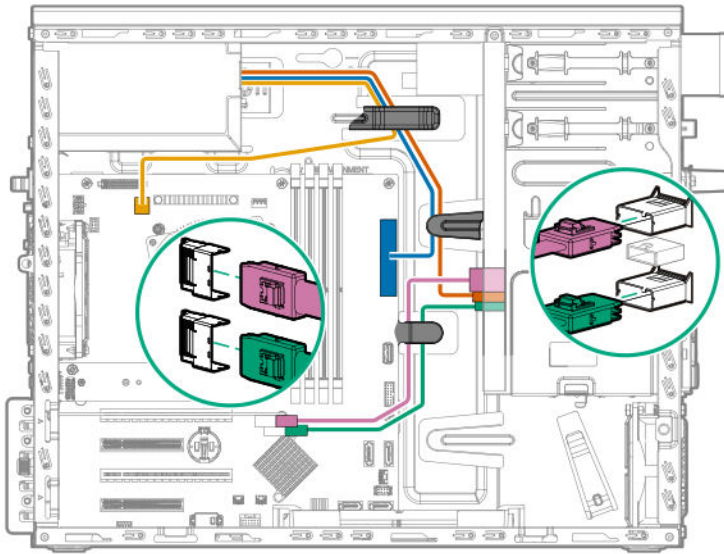

Cable color	Description
Orange	Drive power cable
Blue	24-pin power supply cable
Gold	4-pin power supply cable
Pink	Mini-SAS cable from controller port 1 to drive backplane port 1
Green	Mini-SAS cable from controller port 2 to drive backplane port 2

SFF hot-plug drive cabling with Flexible Slot power supply

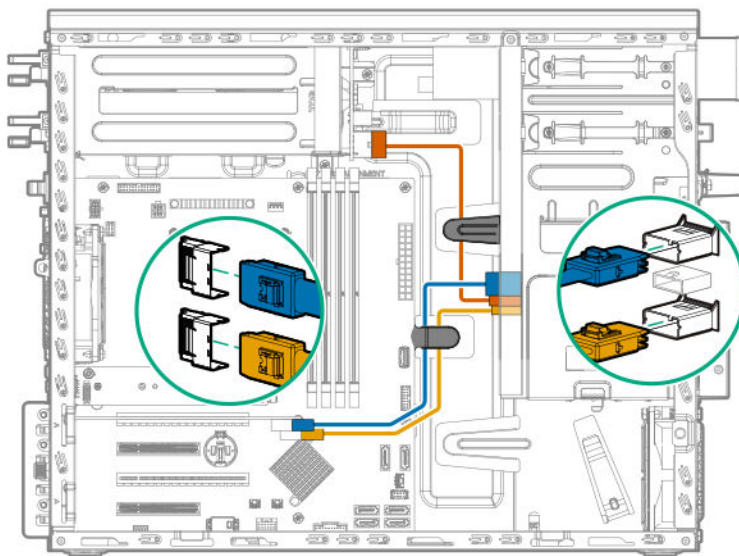

Cable color	Description
Orange	Drive power cable
Blue	Mini-SAS cable from controller port 1 to drive backplane port 1
Gold	Mini-SAS cable from controller port 2 to drive backplane port 2

SFF hot-plug drive cabling for controller with standard power supply

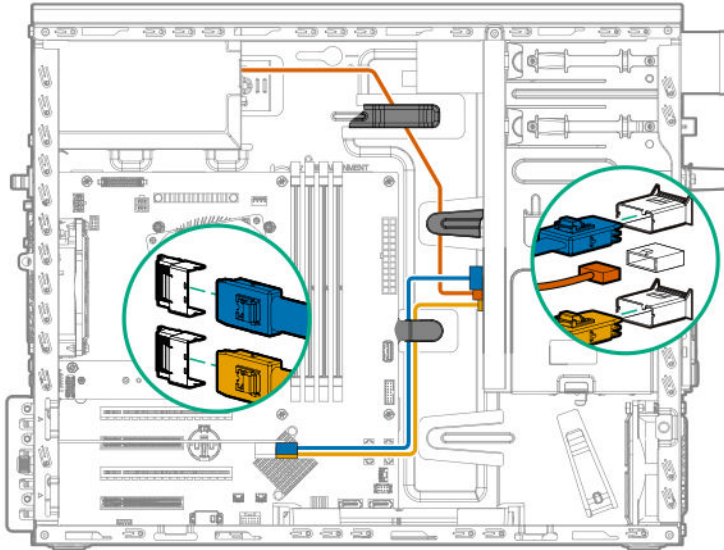

Cable color	Description
Orange	Drive power cable
Blue	Mini-SAS cable from controller port 1 to drive backplane port 1
Gold	Mini-SAS cable from controller port 2 to drive backplane port 2

SFF hot-plug drive cabling for controller with Flexible Slot power supply

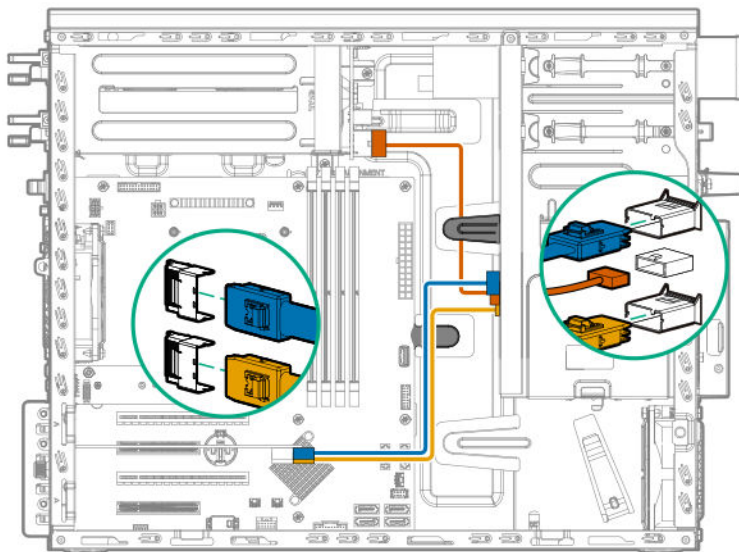

Cable color	Description
Orange	Drive power cable
Blue	Mini-SAS cable from controller port 1 to drive backplane port 1
Gold	Mini-SAS cable from controller port 2 to drive backplane port 2

Energy pack cabling

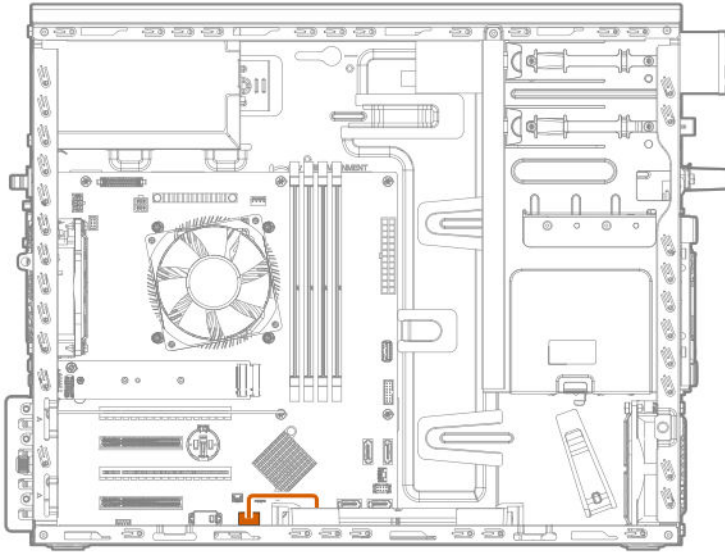

Controller backup power cabling

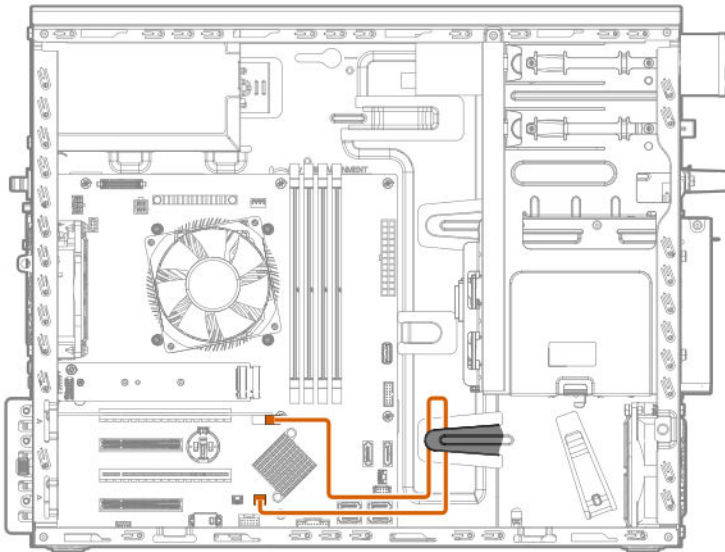

Media device cabling

SATA optical drive cabling

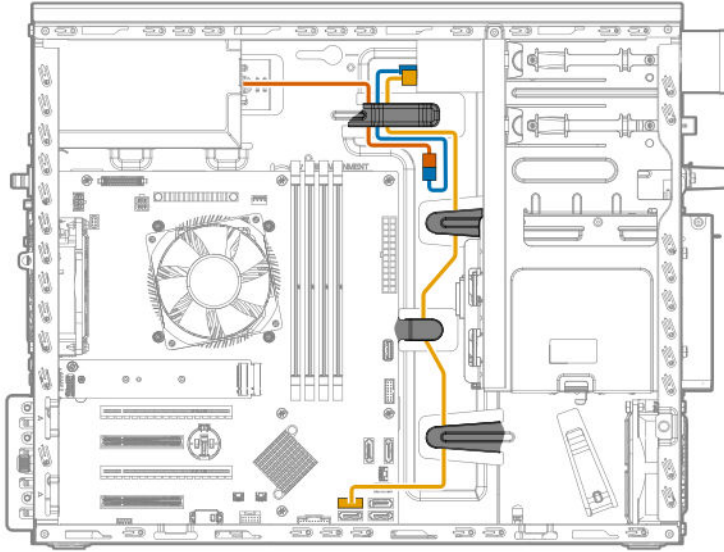

Cable color	Description
Orange	Power supply cable
Blue	Optical drive power cable
Gold	Optical drive SATA cable

SAS LTO tape drive cabling

SAS LTO tape drive with standard power supply

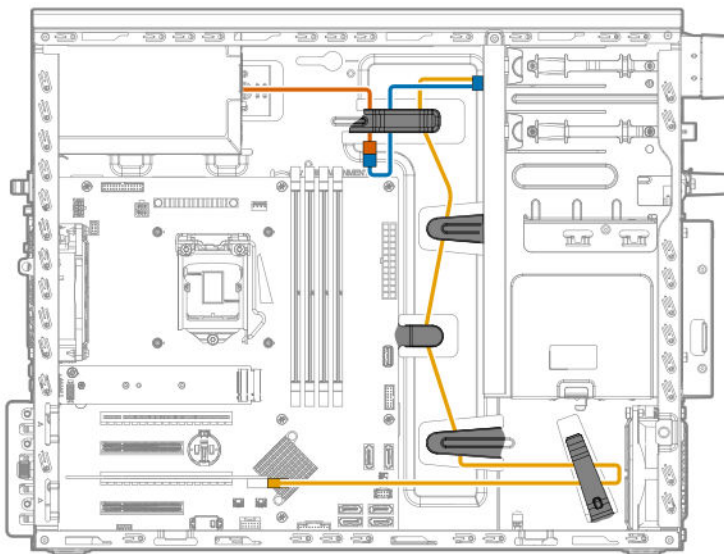

Cable color	Description
Orange	Power supply cable
Blue	SAS LTO tape drive power cable
Gold	SAS LTO tape drive cable

SAS LTO tape drive with Flexible Slot power supply

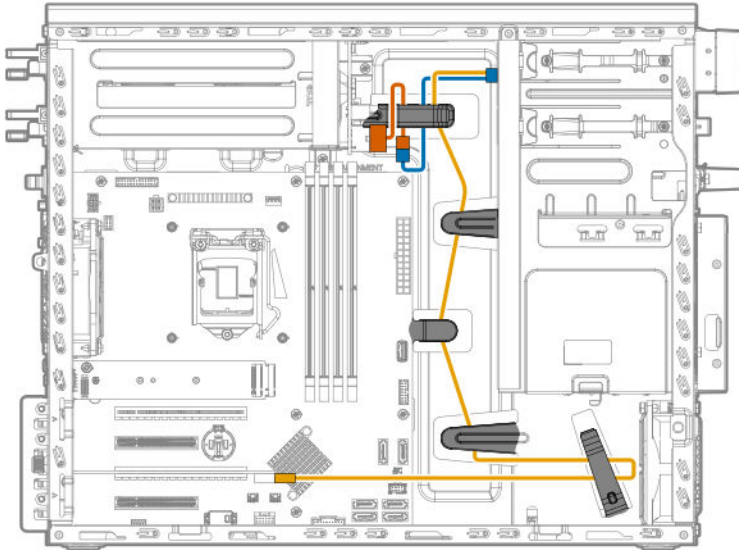

Cable color	Description
Orange	Power supply cable
Blue	SAS LTO tape drive power cable
Gold	SAS LTO tape drive cable

USB RDX drive cabling

USB RDX drive with standard power supply cabling

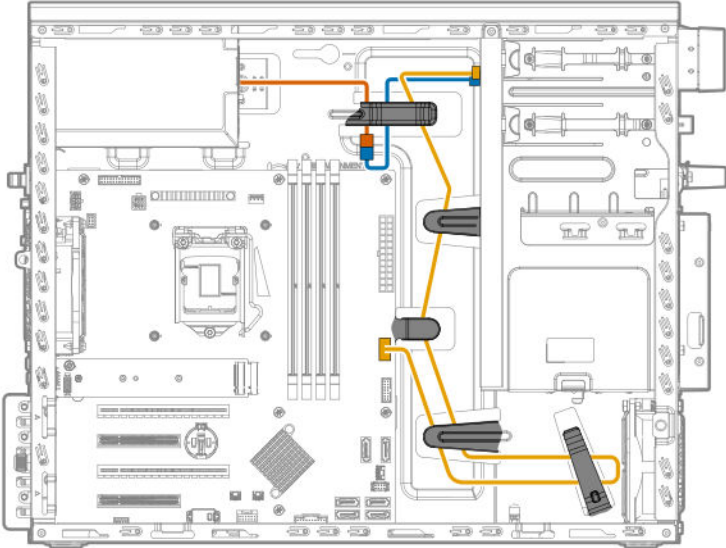

Cable color	Description
Orange	Power supply cable
Blue	USB RDX drive power cable
Gold	USB RDX drive cable

USB RDX drive with Flexible Slot power supply cabling

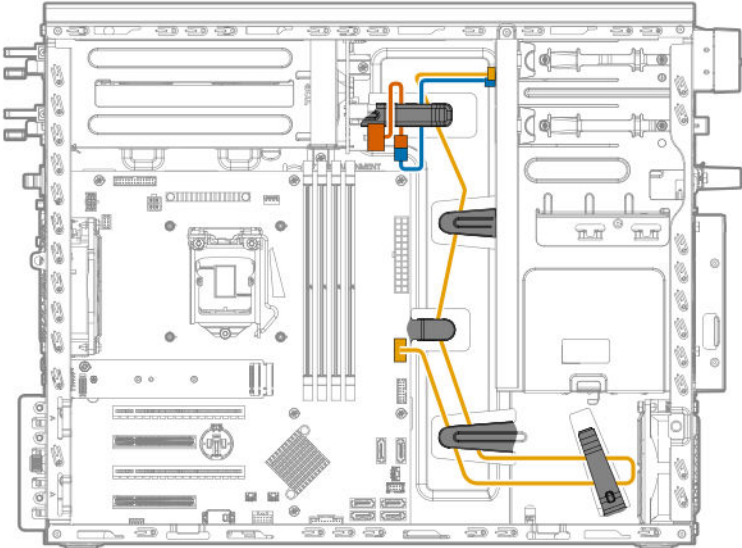

Cable color	Description
Orange	Power supply cable
Blue	USB RDX drive power cable
Gold	USB RDX drive cable

Serial port cabling

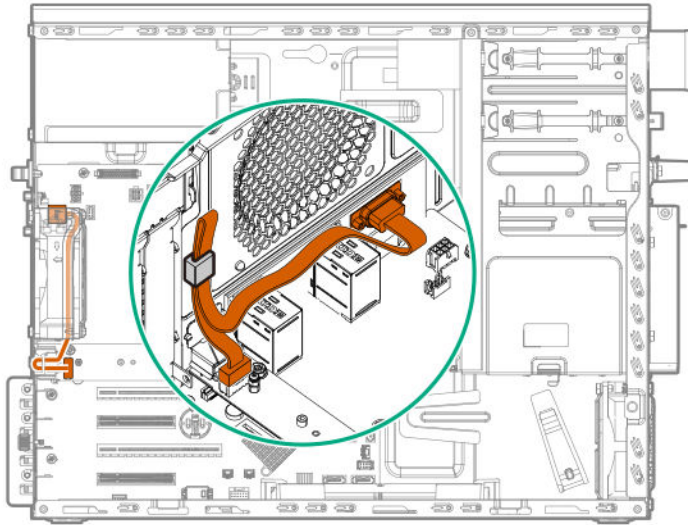

Fan cabling

System fan cabling

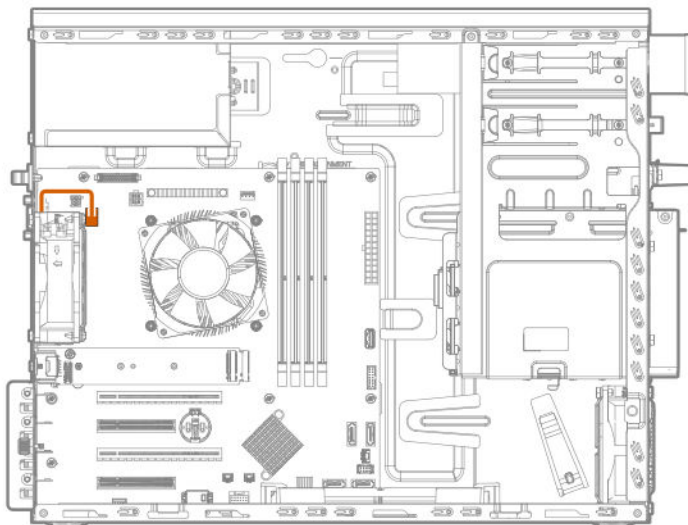

Heatsink fan cabling

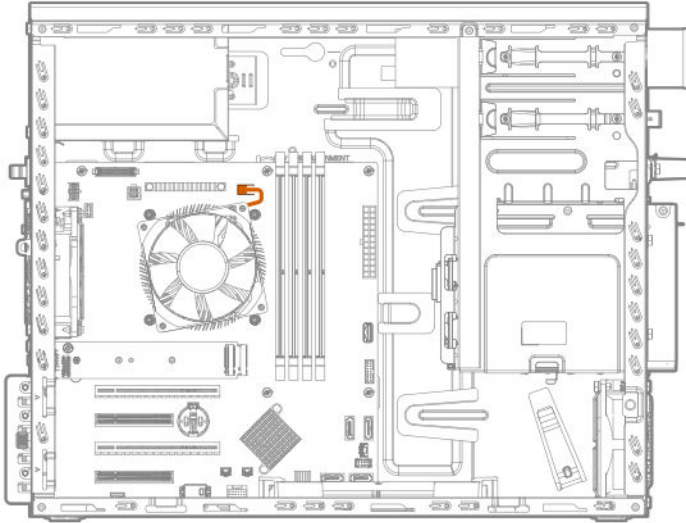

PCI fan cabling

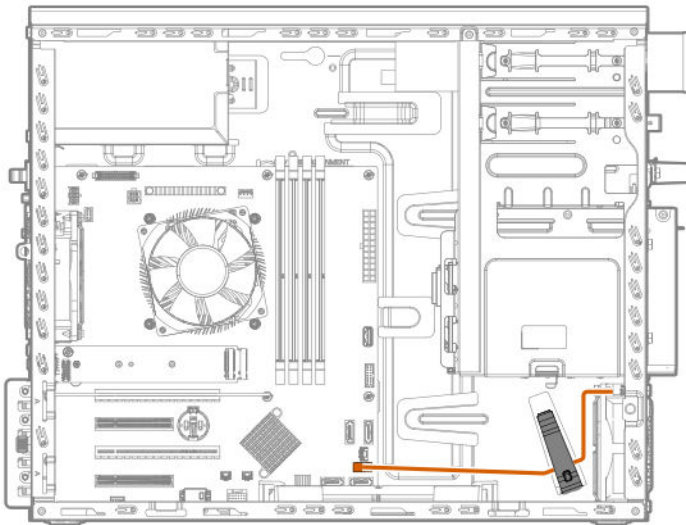

Power supply cabling

Standard power supply cabling

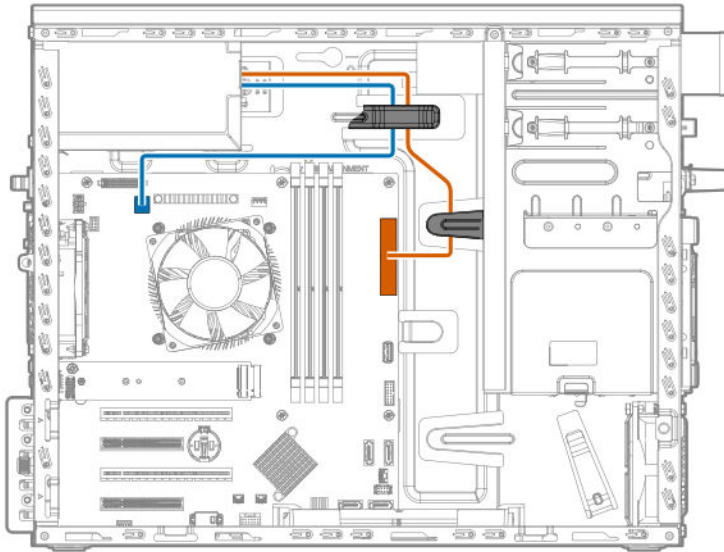

Cable color	Description
Orange	24-pin power supply cable
Blue	4-pin power supply cable

Flexible Slot power supply cabling

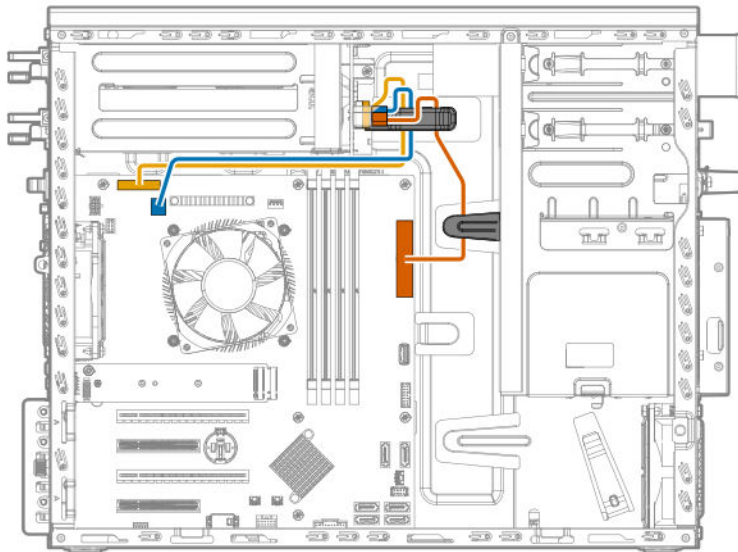

Cable color	Description
Orange	24-pin power supply cable
Blue	4-pin power supply cable
Gold	26-pin sideband power cable

Front I/O cabling

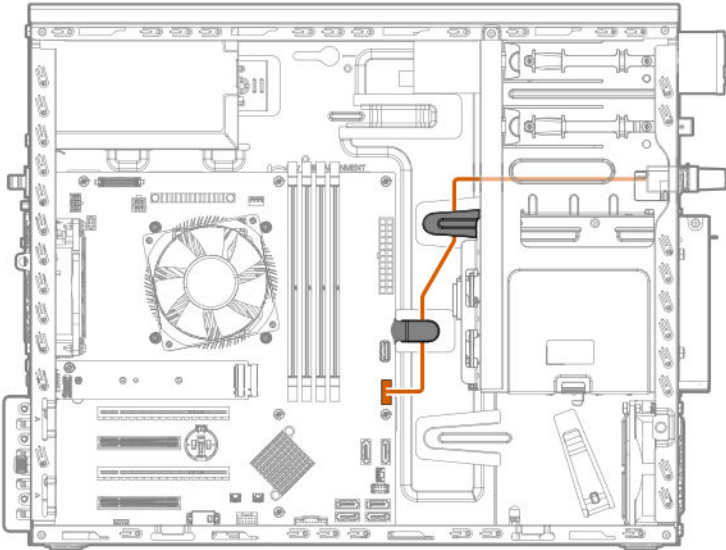

Front USB cabling

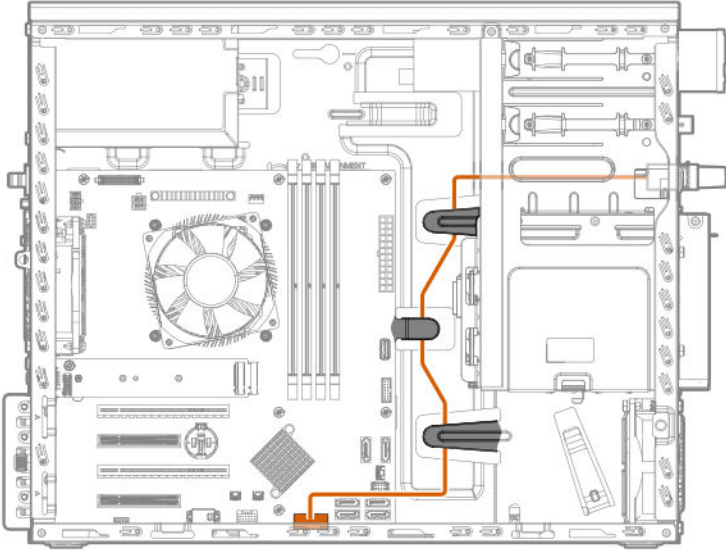

Software and configuration utilities

Server mode

The software and configuration utilities presented in this section operate in online mode, offline mode, or in both modes.

Software or configuration utility	Server mode
<u>Active Health System</u>	Online and Offline
<u>HPE iLO 5</u>	Online and Offline
<u>HPE Smart Storage Administrator</u>	Online and Offline
<u>iLO RESTful API</u>	Online and Offline
<u>Intelligent Provisioning</u>	Online and Offline
<u>Scripting Toolkit for Windows and Linux</u>	Online
<u>Service Pack for ProLiant</u>	Online and Offline
<u>Smart Update Manager</u>	Online and Offline
<u>UEFI System Utilities</u>	Offline

Product QuickSpecs

For more information about product features, specifications, options, configurations, and compatibility, see the product QuickSpecs on the Hewlett Packard Enterprise website (<http://www.hpe.com/info/qs>).

Active Health System Viewer

Active Health System Viewer (AHSV) is an online tool used to read, diagnose, and resolve server issues quickly using AHS uploaded data. AHSV provides Hewlett Packard Enterprise recommended repair actions based on experience and best practices. AHSV provides the ability to:

- Read server configuration information
- View Driver/Firmware inventory
- Review Event Logs
- Respond to Fault Detection Analytics alerts
- Open new and update existing support cases

Active Health System

The Active Health System monitors and records changes in the server hardware and system configuration.

The Active Health System provides:

- Continuous health monitoring of over 1600 system parameters
- Logging of all configuration changes
- Consolidated health and service alerts with precise time stamps
- Agentless monitoring that does not affect application performance

For more information about the Active Health System, see the iLO user guide at the following website: <http://www.hpe.com/support/ilo-docs>.

Active Health System data collection

The Active Health System does not collect information about your operations, finances, customers, employees, or partners.

Examples of information that is collected:

- Server model and serial number
- Processor model and speed
- Storage capacity and speed
- Memory capacity and speed
- Firmware/BIOS and driver versions and settings

The Active Health System does not parse or change OS data from third-party error event log activities (for example, content created or passed through the OS).

Active Health System Log

The data collected by the Active Health System is stored in the Active Health System Log. The data is logged securely, isolated from the operating system, and separate from customer data. Host resources are not consumed in the collection and logging of Active Health System data.

When the Active Health System Log is full, new data overwrites the oldest data in the log.

It takes less than 5 minutes to download the Active Health System Log and send it to a support professional to help you resolve an issue.

When you download and send Active Health System data to Hewlett Packard Enterprise, you agree to have the data used for analysis, technical resolution, and quality improvements. The data that is collected is managed according to the privacy statement, available at <http://www.hpe.com/info/privacy>.

You can also upload the log to the Active Health System Viewer. For more information, see the Active Health System Viewer documentation at the following website: <http://www.hpe.com/support/ahsv-docs>.

HPE iLO 5

iLO 5 is a remote server management processor embedded on the system boards of HPE ProLiant servers and Synergy compute modules. iLO enables the monitoring and controlling of servers from remote locations. iLO management is a powerful tool that provides multiple ways to configure, update, monitor, and repair servers remotely. iLO (Standard) comes preconfigured on Hewlett Packard Enterprise servers without an additional cost or license.

Features that enhance server administrator productivity and additional new security features are licensed. For more information, see the iLO licensing guide at the following website: <http://www.hpe.com/support/ilo-docs>.

For more information about iLO, see the iLO user guide at the following website: <http://www.hpe.com/support/ilo-docs>.

iLO Federation

iLO Federation enables you to manage multiple servers from one system using the iLO web interface.

When configured for iLO Federation, iLO uses multicast discovery and peer-to-peer communication to enable communication between the systems in iLO Federation groups.

When you navigate to one of the iLO Federation pages, a data request is sent from the iLO system running the web interface to its peers, and from those peers to other peers until all data for the selected iLO Federation group is retrieved.

iLO supports the following features:

- Group health status—View server health and model information.
- Group virtual media—Connect URL-based media for access by a group of servers.
- Group power control—Manage the power status of a group of servers.
- Group power capping—Set dynamic power caps for a group of servers.
- Group firmware update—Update the firmware of a group of servers.
- Group license installation—Enter a license key to activate iLO licensed features on a group of servers.
- Group configuration—Add iLO Federation group memberships for multiple iLO systems.

Any user can view information on iLO Federation pages, but a license is required for using the following features: Group virtual media, Group power control, Group power capping, Group configuration, and Group firmware update.

For more information about iLO Federation, see the iLO user guide at the following website: <http://www.hpe.com/support/ilo-docs>.

iLO Service Port

The Service Port is a USB port with the label **iLO** on supported servers and compute modules.

To find out if your server or compute module supports this feature, see the server specifications document at the following website: <http://www.hpe.com/info/qs>.

The Service Port is a USB port with the label **iLO** on the front of the server.

When you have physical access to a server, you can use the Service Port to do the following:

- Download the Active Health System Log to a supported USB flash drive.
When you use this feature, the connected USB flash drive is not accessible by the host operating system.
- Connect a client (such as a laptop) with a supported USB to Ethernet adapter to access the iLO web interface, remote console, CLI, iLO RESTful API, or scripts.
Hewlett Packard Enterprise recommends the HPE USB to Ethernet Adapter (part number Q7Y55A).
Some servers, such as the XL170r, require an adapter to connect a USB to Ethernet adapter to the iLO Service Port.
Hewlett Packard Enterprise recommends the HPE Micro USB to USB Adapter (part number 789904-B21).
- Connect a client (such as a laptop) with a supported USB to Ethernet adapter to access the iLO web interface, remote console, iLO RESTful API, or CLI.

When you use the iLO Service Port:

- Actions are logged in the iLO event log.
- The server UID flashes to indicate the Service Port status.
You can also retrieve the Service Port status by using a REST client and the iLO RESTful API.
- You cannot use the Service Port to boot any device within the server, or the server itself.
- You cannot access the server by connecting to the Service Port.
- You cannot access the connected device from the server.

For more information about the iLO Service Port, see the iLO user guide at the following website: <http://www.hpe.com/support/ilo-docs>.

iLO RESTful API

iLO includes the iLO RESTful API, which is Redfish API conformant. The iLO RESTful API is a management interface that server management tools can use to perform configuration, inventory, and monitoring tasks by sending basic HTTPS operations (GET, PUT, POST, DELETE, and PATCH) to the iLO web server.

To learn more about the iLO RESTful API, see the Hewlett Packard Enterprise website (<http://www.hpe.com/support/restfulinterface/docs>).

For specific information about automating tasks using the iLO RESTful API, see libraries and sample code at <http://www.hpe.com/info/redfish>.

 For more information, watch the [Redfish & How it works with HPE Server Management](#) video.

RESTful Interface Tool

The RESTful Interface Tool (iLOREST) is a scripting tool that allows you to automate HPE server management tasks. It provides a set of simplified commands that take advantage of the iLO RESTful API. You can install the tool on your computer for remote use or install it locally on a server with a Windows or Linux Operating System. The RESTful Interface Tool offers an interactive mode, a scriptable mode, and a file-based mode similar to CONREP to help decrease automation times.

For more information, see the following website: <http://www.hpe.com/info/resttool>.

iLO Amplifier Pack

The iLO Amplifier Pack is an advanced server inventory, firmware and driver update solution that enables rapid discovery, detailed inventory reporting, firmware, and driver updates by leveraging iLO advanced functionality. The iLO Amplifier Pack performs rapid server discovery and inventory for thousands of supported servers for the purpose of updating firmware and drivers at scale.

For more information about iLO Amplifier Pack, see the *iLO Amplifier Pack User Guide* at the following website: <http://www.hpe.com/support/ilo-ap-ug-en>.

Integrated Management Log

The IML records hundreds of events and stores them in an easy-to-view form. The IML timestamps each event with one-minute granularity.

You can view recorded events in the IML in several ways, including the following:

- From within HPE SIM
- From within the UEFI System Utilities

- From within the Embedded UEFI shell
- From within the iLO web interface

Intelligent Provisioning

Intelligent Provisioning is a single-server deployment tool embedded in ProLiant servers and HPE Synergy compute modules. Intelligent Provisioning simplifies server setup, providing a reliable and consistent way to deploy servers.

Intelligent Provisioning 3.30 and later includes HPE Rapid Setup Software. When you launch F10 mode from the POST screen, you are prompted to select whether you want to enter the Intelligent Provisioning or HPE Rapid Setup Software mode.

NOTE: After you have selected a mode, you must re provision the server to change the mode that launches when you boot to F10.

Intelligent Provisioning prepares the system for installing original, licensed vendor media and Hewlett Packard Enterprise-branded versions of OS software. Intelligent Provisioning also prepares the system to integrate optimized server support software from the Service Pack for ProLiant (SPP). SPP is a comprehensive systems software and firmware solution for ProLiant servers, server blades, their enclosures, and HPE Synergy compute modules. These components are preloaded with a basic set of firmware and OS components that are installed along with Intelligent Provisioning.

 **IMPORTANT:** HPE ProLiant DX/XL servers do not support operating system installation with Intelligent Provisioning, but they do support the maintenance features. For more information, see "Performing Maintenance" in the Intelligent Provisioning user guide and online help.

After the server is running, you can update the firmware to install additional components. You can also update any components that have been outdated since the server was manufactured.

To access Intelligent Provisioning:

- Press **F10** from the POST screen and enter either Intelligent Provisioning or HPE Rapid Setup Software.
- From the iLO web interface using **Always On**. **Always On** allows you to access Intelligent Provisioning without rebooting your server.

Intelligent Provisioning operation

Intelligent Provisioning includes the following components:

- Critical boot drivers
- Active Health System (AHS)
- Erase Utility
- Deployment Settings

 **IMPORTANT:**

- Although your server is preloaded with firmware and drivers, Hewlett Packard Enterprise recommends updating the firmware upon initial setup. Also, downloading and updating the latest version of Intelligent Provisioning ensures the latest supported features are available.
- For ProLiant servers, firmware is updated using the Intelligent Provisioning Firmware Update utility.
- Do not update firmware if the version you are currently running is required for compatibility.

NOTE: Intelligent Provisioning does not function within multihomed configurations. A multihomed host is one that is connected to two or more networks or has two or more IP addresses.

Intelligent Provisioning provides installation help for the following operating systems:

- Microsoft Windows Server
- Red Hat Enterprise Linux
- SUSE Linux Enterprise Server
- VMware ESXi/vSphere Custom Image
- ClearOS

Not all versions of an OS are supported. For information about specific versions of a supported operating system, see the OS Support Matrix on the Hewlett Packard Enterprise website (<http://www.hpe.com/info/ossupport>).

Management Security

HPE ProLiant Gen10 servers are built with some of the industry's most advanced security capabilities, out of the box, with a foundation of secure embedded management applications and firmware. The management security provided by HPE embedded management products enables secure support of modern workloads, protecting your components from unauthorized access and unapproved use. The range of embedded management and optional software and firmware available with the iLO Advanced license provides security features that help ensure protection, detection, and recovery from advanced cyber-attacks. For more information, see the *HPE Gen10 Server Security Reference Guide* on the Hewlett Packard Enterprise Information Library at <http://www.hpe.com/support/gen10-security-ref-en>.

Scripting Toolkit for Windows and Linux

The STK for Windows and Linux is a server deployment product that delivers an unattended automated installation for high-volume server deployments. The STK is designed to support ProLiant servers. The toolkit includes a modular set of utilities and important documentation that describes how to apply these tools to build an automated server deployment process.

The STK provides a flexible way to create standard server configuration scripts. These scripts are used to automate many of the manual steps in the server configuration process. This automated server configuration process cuts time from each deployment, making it possible to scale rapid, high-volume server deployments.

For more information or to download the STK, see the [Hewlett Packard Enterprise website](#).

UEFI System Utilities

The UEFI System Utilities is embedded in the system ROM. Its features enable you to perform a wide range of configuration activities, including:

- Configuring system devices and installed options.
- Enabling and disabling system features.
- Displaying system information.
- Selecting the primary boot controller or partition.

- Configuring memory options.
- Launching other preboot environments.

HPE servers with UEFI can provide:

- Support for boot partitions larger than 2.2 TB. Such configurations could previously only be used for boot drives when using RAID solutions.
- Secure Boot that enables the system firmware, option card firmware, operating systems, and software collaborate to enhance platform security.
- UEFI Graphical User Interface (GUI)
- An Embedded UEFI Shell that provides a preboot environment for running scripts and tools.
- Boot support for option cards that only support a UEFI option ROM.

Selecting the boot mode

This server provides two **Boot Mode** configurations: UEFI Mode and Legacy BIOS Mode. Certain boot options require that you select a specific boot mode. By default, the boot mode is set to **UEFI Mode**. The system must boot in **UEFI Mode** to use certain options, including:

- Secure Boot, UEFI Optimized Boot, Generic USB Boot, IPv6 PXE Boot, iSCSI Boot, and Boot from URL
- Fibre Channel/FCoE Scan Policy

NOTE: The boot mode you use must match the operating system installation. If not, changing the boot mode can impact the ability of the server to boot to the installed operating system.

Prerequisite

When booting to **UEFI Mode**, leave **UEFI Optimized Boot** enabled.

Procedure

1. From the **System Utilities** screen, select **System Configuration > BIOS/Platform Configuration (RBSU) > Boot Options > Boot Mode**.
2. Select a setting.
 - **UEFI Mode** (default)—Configures the system to boot to a UEFI compatible operating system.
 - **Legacy BIOS Mode**—Configures the system to boot to a traditional operating system in Legacy BIOS compatibility mode.
3. Save your setting.
4. Reboot the server.

Secure Boot

Secure Boot is a server security feature that is implemented in the BIOS and does not require special hardware. Secure Boot ensures that each component launched during the boot process is digitally signed and that the signature is validated against a set of trusted certificates embedded in the UEFI BIOS. Secure Boot validates the software identity of the following components in the boot process:

- UEFI drivers loaded from PCIe cards
- UEFI drivers loaded from mass storage devices
- Preboot UEFI Shell applications
- OS UEFI boot loaders

When Secure Boot is enabled:

- Firmware components and operating systems with boot loaders must have an appropriate digital signature to execute during the boot process.
- Operating systems must support Secure Boot and have an EFI boot loader signed with one of the authorized keys to boot. For more information about supported operating systems, see <http://www.hpe.com/servers/ossupport>.

You can customize the certificates embedded in the UEFI BIOS by adding or removing your own certificates, either from a management console directly attached to the server, or by remotely connecting to the server using the iLO Remote Console.

You can configure Secure Boot:

- Using the **System Utilities** options described in the following sections.
- Using the iLO RESTful API to clear and restore certificates. For more information, see the Hewlett Packard Enterprise website (<http://www.hpe.com/info/redfish>).
- Using the `secboot` command in the Embedded UEFI Shell to display Secure Boot databases, keys, and security reports.

Launching the Embedded UEFI Shell

Use the **Embedded UEFI Shell** option to launch the Embedded UEFI Shell. The Embedded UEFI Shell is a preboot command-line environment for scripting and running UEFI applications, including UEFI boot loaders. The Shell also provides CLI-based commands you can use to obtain system information, and to configure and update the system BIOS.

Prerequisites

Embedded UEFI Shell is set to **Enabled**.

Procedure

1. From the **System Utilities** screen, select **Embedded Applications > Embedded UEFI Shell**.

The **Embedded UEFI Shell** screen appears.

2. Press any key to acknowledge that you are physically present.

This step ensures that certain features, such as disabling **Secure Boot** or managing the **Secure Boot** certificates using third-party UEFI tools, are not restricted.

3. If an administrator password is set, enter it at the prompt and press **Enter**.

The `Shell>` prompt appears.

4. Enter the commands required to complete your task.

5. Enter the `exit` command to exit the Shell.

HPE Smart Storage Administrator

HPE SSA is the main tool for configuring arrays on HPE Smart Array SR controllers. It exists in three interface formats: the HPE SSA GUI, the HPE SSA CLI, and HPE SSA Scripting. All formats provide support for configuration tasks. Some of the advanced tasks are available in only one format.

The diagnostic features in HPE SSA are also available in the standalone software HPE Smart Storage Administrator Diagnostics Utility CLI.

During the initial provisioning of the server or compute module, an array is required to be configured before the operating system can be installed. You can configure the array using SSA.

HPE SSA is accessible both offline (either through HPE Intelligent Provisioning or as a standalone bootable ISO image) and online:

- Accessing HPE SSA in the offline environment

! **IMPORTANT:** If you are updating an existing server in an offline environment, obtain the latest version of HPE SSA through Service Pack for ProLiant before performing configuration procedures.

Using one of multiple methods, you can run HPE SSA before launching the host operating system. In offline mode, users can configure or maintain detected and supported devices, such as optional Smart Array controllers and integrated Smart Array controllers. Some HPE SSA features are only available in the offline environment, such as setting the boot controller and boot volume.

- Accessing HPE SSA in the online environment

This method requires an administrator to download the HPE SSA executables and install them. You can run HPE SSA online after launching the host operating system.

For more information, see *HPE Smart Array SR Gen10 Configuration Guide* at the [Hewlett Packard Enterprise website](#).

HPE InfoSight for servers

The HPE InfoSight portal is a secure web interface hosted by HPE that allows you to monitor supported devices through a graphical interface.

HPE InfoSight for servers:

- Combines the machine learning and predictive analytics of HPE InfoSight with the health and performance monitoring of Active Health System (AHS) and HPE iLO to optimize performance and predict and prevent problems
- Provides automatic collection and analysis of the sensor and telemetry data from AHS to derive insights from the behaviors of the install base to provide recommendations to resolve problems and improve performance

For more information on getting started and using HPE InfoSight for servers, go to: <http://www.hpe.com/info/infosight-servers-docs>.

USB support

Hewlett Packard Enterprise Gen10 servers support all USB operating speeds depending on the device that is connected to the server.

External USB functionality

Hewlett Packard Enterprise provides external USB support to enable local connection of USB devices for server administration, configuration, and diagnostic procedures.

For additional security, external USB functionality can be disabled through USB options in UEFI System Utilities.

Redundant ROM support

The server enables you to upgrade or configure the ROM safely with redundant ROM support. The server has a single ROM that acts as two separate ROM images. In the standard implementation, one side of the ROM contains the current ROM program version, while the other side of the ROM contains a backup version.

NOTE: The server ships with the same version programmed on each side of the ROM.

Safety and security benefits

When you flash the system ROM, the flashing mechanism writes over the backup ROM and saves the current ROM as a backup, enabling you to switch easily to the alternate ROM version if the new ROM becomes corrupted for any reason. This feature protects the existing ROM version, even if you experience a power failure while flashing the ROM.

Keeping the system current

Updating firmware or system ROM

To update firmware or system ROM, use one of the following methods:

- The **Firmware Update** option in the System Utilities.
- The `fwupdate` command in the **Embedded UEFI Shell**.
- Service Pack for ProLiant (SPP)
- HPE online flash components
- Moonshot Component Pack

Service Pack for ProLiant

SPP is a systems software and firmware solution delivered as a single ISO file download. This solution uses SUM as the deployment tool and is tested and supports HPE ProLiant, HPE BladeSystem, HPE Synergy, and HPE Apollo servers and infrastructure.

SPP, along with SUM and iSUT, provides Smart Update system maintenance tools that systematically update HPE ProLiant, HPE BladeSystem, HPE Synergy, and HPE Apollo servers and infrastructure.

SPP can be used in an online mode on a server running Windows, Linux, or VMware vSphere ESXi, or in an offline mode where the server is booted to an operating system included in the ISO file.

The preferred method for downloading an SPP is using the SPP Custom Download at <https://www.hpe.com/servers/spp/custom>.

The SPP is also available for download from the SPP download page at <https://www.hpe.com/servers/spp/download>.

Smart Update Manager

SUM is an innovative tool for maintaining and updating the firmware, drivers, and system software of HPE ProLiant, HPE BladeSystem, HPE Synergy, and HPE Apollo servers, infrastructure, and associated options.

SUM identifies associated nodes you can update at the same time to avoid interdependency issues.

Key features of SUM include:

- Discovery engine that finds installed versions of hardware, firmware, and software on nodes.
- SUM deploys updates in the correct order and ensures that all dependencies are met before deploying an update.
- Interdependency checking.
- Automatic and step-by-step Localhost Guided Update process.
- Web browser-based user interface.
- Ability to create custom baselines and ISOs.
- Support for iLO Repository (Gen10 iLO 5 nodes only).
- Simultaneous firmware and software deployment for multiple remote nodes.
- Local offline firmware deployments with SPP deliverables.
- Extensive logging in all modes.

NOTE: SUM does not support third-party controllers, including flashing hard drives behind the controllers.

Smart Update Tools

Smart Update Tools is a software utility used with iLO 4, HPE OneView, Service Pack for ProLiant (SPP), and Smart Update Manager (SUM) to stage, install, and activate firmware and driver updates.

NOTE: HPE OneView manages the iLO while iSUT runs on each server and deploys the updates. The same tool might not manage both applications. Create a process that notifies the administrators when updates are available.

- **Smart Update Tools:** Polls iLO to check for requests from HPE OneView for updates through the management network and orchestrates staging, deploying, and activating updates. You can adjust the polling interval by issuing the appropriate command-line option provided by iSUT. Performs inventory on target servers, stages deployment, deploys updates, and then reboots the servers.
- **HPE OneView:** Displays available updates for servers. Communicates with iSUT (or SUT 1.x) to initiate updates, reports the status on the **Firmware** section of the **Server Profile** page of HPE OneView. HPE OneView provides automated compliance reporting in the dashboard.
- **SPP:** A comprehensive systems software and firmware update solution, which is delivered as a single ISO image.
- **SUM:** A tool for firmware and driver maintenance for HPE ProLiant servers and associated options.

NOTE: Do not manage the same nodes with SUM and HPE OneView at the same time.

Updating firmware from the System Utilities

Use the **Firmware Updates** option to update firmware components in the system, including the system BIOS, NICs, and storage cards.

Procedure

1. Access the System ROM Flash Binary component for your server from the Hewlett Packard Enterprise Support Center.
2. Copy the binary file to a USB media or iLO virtual media.
3. Attach the media to the server.
4. Launch the **System Utilities**, and select **Embedded Applications > Firmware Update**.

5. Select a device.

The **Firmware Updates** screen lists details about your selected device, including the current firmware version in use.

6. Select **Select Firmware File**.

7. Select the flash file in the **File Explorer** list.

The firmware file is loaded and the **Firmware Updates** screen lists details of the file in the **Selected firmware file** field.

8. Select **Image Description**, and then select a firmware image.

A device can have multiple firmware images.

9. Select **Start firmware update**.

Updating the firmware from the UEFI Embedded Shell

Procedure

1. Access the System ROM Flash Binary component for your server from the Hewlett Packard Enterprise Support Center (<http://www.hpe.com/support/hpesc>).
2. Copy the binary file to a USB media or iLO virtual media.
3. Attach the media to the server.
4. Boot to the UEFI Embedded Shell.
5. To obtain the assigned file system volume for the USB key, enter `map -r`.
6. Change to the file system that contains the System ROM Flash Binary component for your server. Enter one of the `fsx` file systems available, such as `fs0:` or `fs1:`, and press **Enter**.
7. Use the `cd` command to change from the current directory to the directory that contains the binary file.
8. Flash the system ROM by entering `fwupdate -d BIOS -f filename`.
9. Reboot the server. A reboot is required after the firmware update in order for the updates to take effect and for hardware stability to be maintained.

Online Flash components

This component provides updated system firmware that can be installed directly on supported operating systems. Additionally, when used in conjunction with SUM, this Smart Component allows the user to update firmware on remote servers from a central location. This remote deployment capability eliminates the need for the user to be physically present at the server to perform a firmware update.

Drivers

 **IMPORTANT:** Always perform a backup before installing or updating device drivers.

Update drivers using any of the following **Smart Update Solutions**:

- Download the latest Service Pack for ProLiant (includes Smart Update Manager)
- Create a custom SPP download

- Download Smart Update Manager for Linux
- Download specific drivers

To locate the drivers for a server, go to the **Hewlett Packard Enterprise Support Center website**, and then search for the product name/number.

Software and firmware

Update software and firmware before using the server for the first time, unless any installed software or components require an older version.

For system software and firmware updates, use one of the following sources:

- Download the SPP from the Hewlett Packard Enterprise website (<http://www.hpe.com/servers/spp/download>).
- Download individual drivers, firmware, or other system software components from the server product page in the Hewlett Packard Enterprise Support Center website (<http://www.hpe.com/support/hpesc>).

Operating system version support

For information about specific versions of a supported operating system, refer to the **operating system support matrix**.

HPE Pointnext Portfolio

HPE Pointnext delivers confidence, reduces risk, and helps customers realize agility and stability. Hewlett Packard Enterprise helps customers succeed through Hybrid IT by simplifying and enriching the on-premise experience, informed by public cloud qualities and attributes.

Operational Support Services enable you to choose the right service level, length of coverage, and response time to fit your business needs. For more information, see the Hewlett Packard Enterprise website:

<https://www.hpe.com/us/en/services/operational.html>

Utilize the Advisory and Transformation Services in the following areas:

- Private or hybrid cloud computing
- Big data and mobility requirements
- Improving data center infrastructure
- Better use of server, storage, and networking technology

For more information, see the Hewlett Packard Enterprise website:

<http://www.hpe.com/services/consulting>

Proactive notifications

30 to 60 days in advance, Hewlett Packard Enterprise sends notifications to subscribed customers on upcoming:

- Hardware, firmware, and software changes
- Bulletins
- Patches
- Security alerts

You can subscribe to proactive notifications on the **Hewlett Packard Enterprise website**.

Troubleshooting

NMI functionality

An NMI crash dump enables administrators to create crash dump files when a system is hung and not responding to traditional debugging methods.

An analysis of the crash dump log is an essential part of diagnosing reliability problems, such as hanging operating systems, device drivers, and applications. Many crashes freeze a system, and the only available action for administrators is to cycle the system power. Resetting the system erases any information that could support problem analysis, but the NMI feature preserves that information by performing a memory dump before a hard reset.

To force the OS to invoke the NMI handler and generate a crash dump log, the administrator can use the iLO Virtual NMI feature.

Troubleshooting resources

Troubleshooting resources are available for HPE Gen10 server products in the following documents:

- *Troubleshooting Guide for HPE ProLiant Gen10 servers* provides procedures for resolving common problems and comprehensive courses of action for fault isolation and identification, issue resolution, and software maintenance.
- *Error Message Guide for HPE ProLiant Gen10 servers and HPE Synergy* provides a list of error messages and information to assist with interpreting and resolving error messages.
- *Integrated Management Log Messages and Troubleshooting Guide for HPE ProLiant Gen10 and HPE Synergy* provides IML messages and associated troubleshooting information to resolve critical and cautionary IML events.

To access the troubleshooting resources, see the Hewlett Packard Enterprise Information Library (<http://www.hpe.com/info/gen10-troubleshooting>).

System battery replacement

System battery information

The server contains an internal lithium manganese dioxide, a vanadium pentoxide, or an alkaline battery that provides power to the real-time clock. If this battery is not properly handled, a risk of the fire and burns exists. To reduce the risk of personal injury:

- Do not attempt to recharge the battery.
- Do not expose the battery to temperatures higher than 60°C (140°F).
- Do not expose the battery to extremely low air pressure as it might lead to explosion or leakage of flammable liquid or gas.
- Do not disassemble, crush, puncture, short external contacts, or dispose the battery in fire or water.
- If the server no longer automatically displays the correct date and time, then replace the battery that provides power to the real-time clock. Under normal use, battery life is 5 to 10 years.

Removing and replacing the system battery

Procedure

1. **Power down the server.**
2. Remove all power:
 - a. Disconnect each power cord from the power source.
 - b. Disconnect each power cord from the server.
3. Disconnect all peripheral cables from the server.
4. Do one of the following:
 - If the server is in tower mode: **Position the tower server for hardware configuration.**
 - If the server is in rack mode: **Remove the server from the rack.**
5. **Remove the front bezel.**
6. **Remove the access panel.**
7. If installed, **remove the air baffle.**
8. **Locate the battery on the system board.**
9. Remove the system battery:
 - a. Use a small flat-bladed, nonconductive tool to press the battery latch. (callout 1).
 - b. Remove the system battery from the socket (callout 2).

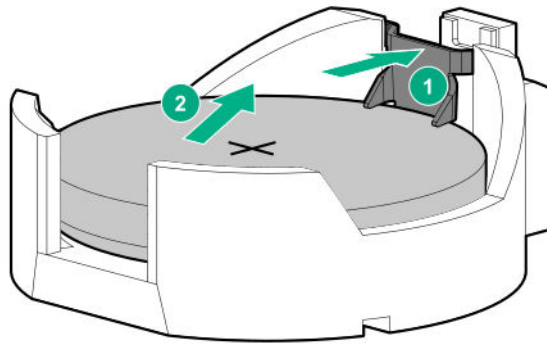

10. Install the system battery:

- a. With the side of the battery showing the "+" sign facing up, insert the battery into the socket (callout 1).
- b. Press the system battery down until it clicks into place (callout 2).

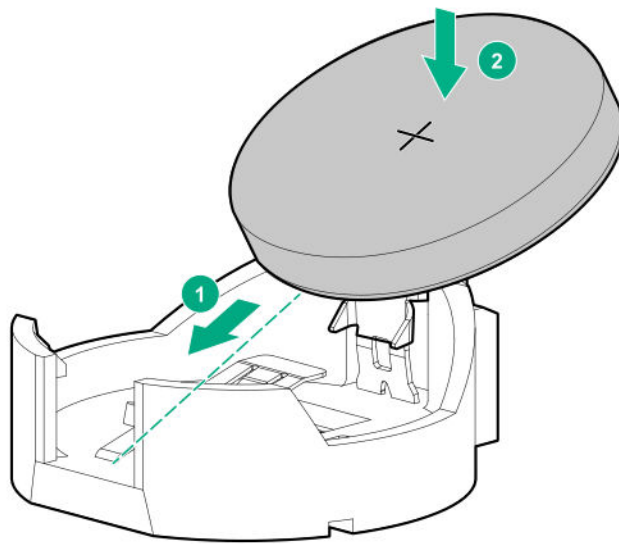

11. Install the access panel.

12. Install the front bezel.

13. Do one of the following:

If the server is in tower mode: **Position the tower server for operation.**

If the server is in rack mode: **Install the server on the tray.**

14. Connect all peripheral cables to the server.

15. Connect the power cords:

- a. Connect each power cord to the server.
- b. Connect each power cord to the power source.

16. Power up the server.

- 17.** Properly dispose of the old battery.

For more information about battery replacement or proper disposal, contact an authorized reseller or an authorized service provider.

Safety, warranty, and regulatory information

Regulatory information

To view the regulatory information for your product, view the *Safety and Compliance Information for Server, Storage, Power, Networking, and Rack Products*, available at the Hewlett Packard Enterprise Support Center:

<https://www.hpe.com/support/Safety-Compliance-EnterpriseProducts>

Additional regulatory information

Hewlett Packard Enterprise is committed to providing our customers with information about the chemical substances in our products as needed to comply with legal requirements such as REACH (Regulation EC No 1907/2006 of the European Parliament and the Council). A chemical information report for this product can be found at:

<https://www.hpe.com/info/reach>

For Hewlett Packard Enterprise product environmental and safety information and compliance data, including RoHS and REACH, see:

<https://www.hpe.com/info/ecodata>

For Hewlett Packard Enterprise environmental information, including company programs, product recycling, and energy efficiency, see:

<https://www.hpe.com/info/environment>

Notices for Eurasian Economic Union



Manufacturer and Local Representative Information

Manufacturer information:

Hewlett Packard Enterprise, 6280 America Center Drive, San Jose, CA 95002 U.S.

Local representative information Russian:

- **Russia**

ООО "Хьюлетт Паккард Энтерпрайз", Российская Федерация, 125171, г. Москва, Ленинградское шоссе, 16А, стр.3, Телефон: +7 499 403 4248 Факс: +7 499 403 4677

- **Kazakhstan**

ТОО «Хьюлетт-Паккард (К)», Республика Казахстан, 050040, г. Алматы, Бостандыкский район, проспект Аль-Фараби, 77/7, Телефон/факс: + 7 727 355 35 50

Local representative information Kazakh:

- **Russia**

ЖШС "Хьюлетт Паккард Энтерпрайз", Ресей Федерациясы, 125171, Мәскеу, Ленинград тас жолы, 16А блок 3, Телефон: +7 499 403 4248 Факс: +7 499 403 4677

- **Kazakhstan**

ЖШС «Хьюлетт-Паккард (К)», Қазақстан Республикасы, 050040, Алматы қ., Бостандық ауданы,
Әл-Фараби даңғылы, 77/7, Телефон/факс: +7 727 355 35 50

Manufacturing date:

The manufacturing date is defined by the serial number.

CCSYWWZZZZ (product serial number format)

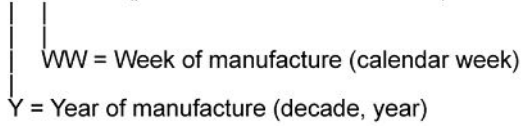

If you need help identifying the manufacturing date, contact tre@hpe.com.

Turkey RoHS material content declaration

Türkiye Cumhuriyeti: AEEE Yönetmeliğine Uygundur

Ukraine RoHS material content declaration

Обладнання відповідає вимогам Технічного регламенту щодо обмеження використання деяких небезпечних речовин в електричному та електронному обладнанні, затвердженого постановою Кабінету Міністрів України від 3 грудня 2008 № 1057

GS Gloss declaration

The product is not suitable for use at visual display workplaces according to §2 of the German Ordinance for Work with Visual Display Units.

Das Produkt ist nicht für den Einsatz an Bildschirmarbeitsplätzen im Sinne § 2 der Bildschirmarbeitsverordnung geeignet.

Specifications

Environmental specifications

Specification	Value
Temperature range¹	—
Operating	10°C to 35°C (50°F to 95°F)
Nonoperating	-30°C to 60°C (-22°F to 140°F)
Relative humidity (noncondensing)	—
Operating	10% to 90% 28°C (82.4°F) maximum web bulb temperature
Nonoperating	5% to 95% 38.7°C (101.7°F), maximum wet bulb temperature

¹ All temperature ratings shown are for sea level. An altitude derating of 1.0° per 304.8 m (1.8°F per 1000 ft) to 3048 m (10,000 ft) is applicable. No direct sunlight allowed.

For certain approved hardware configurations, the supported system inlet temperature range is extended:

- 5°C to 10°C (41°F to 50°F) and 35°C to 40°C (95°F to 104°F) at sea level with an altitude derating of 1.0°C per every 175 m (1.8°F per every 574 ft) above 900 m (2953 ft) to a maximum of 3050 m (10,000 ft).
- 40°C to 45°C (104°F to 113°F) at sea level with an altitude derating of 1.0°C per every 125 m (1.8°F per every 410 ft) above 900 m (2953 ft) to a maximum of 3048 m (10,000 ft).

Server specifications

Specification	Value
Height	36.83 cm (14.50 in)
Depth	47.50 cm (18.70 in)
Width	17.50 cm (6.89 in)
Weight (maximum load, approximate values)	—
Four-bay LFF non-hot-plug drive model	15.24 kg (33.59 lb)
Four-bay LFF hot-plug drive model	17.60 kg (38.80 lb)
Eight-bay SFF hot-plug drive model	15.50 kg (34.17 lb)

Power supply specifications

Depending on the installed options and the regional location where the server was purchased, the server can be configured with one of the following power supplies:

- **HPE 350W E-star 1.0 Non-hot-plug Power Supply**
- **HPE 500W Flex Slot Platinum Hot-plug Low Halogen Power Supply**

For detailed power supply specifications, see the QuickSpecs on the **Hewlett Packard Enterprise website**.

HPE 350W E-star 1.0 Non-hot-plug Power Supply

Specification	Value
Input requirements	—
Rated input voltage	100 VAC to 240 VAC
Rated input frequency	50 Hz to 60 Hz
Rated input current	5A
Rated input power	427 W at 115 VAC 427 W at 240 VAC
Efficiency	No less than 82% at 100% load No less than 85% at 50% load No less than 82% at 20% load
Power supply output	—
Rated steady-state power	350 W at 115 VAC 350 W at 230 VAC
Maximum peak power	350 W at 115 VAC 350 W at 230 VAC
Rated output power	350 W

HPE 500W Flex Slot Platinum Hot-plug Low Halogen Power Supply

Specification	Value
Input requirements	—
Rated input voltage	100 VAC to 240 VAC 240 VDC for China only
Rated input frequency	50 Hz to 60 Hz Not applicable to 240 VDC

Table Continued

Specification	Value
Rated input current	5.8 A at 100 VAC
	2.8 A at 200 VAC
	2.4 A at 240 VDC for China only
Maximum rated input power	557 W at 100 VAC
	539 W at 200 VAC
	537 W at 240 VDC for China only
BTUs per hour	1902 at 100 VAC
	1840 at 200 VAC
	1832 at 240 VDC for China only
Power supply output	—
Rated steady-state power	500 W at 100 VAC to 127 VAC input
	500 W at 100 VAC to 240 VAC input
	500 W at 240 VDC input for China only
Maximum peak power	500 W at 100 VAC to 127 VAC input
	500 W at 100 VAC to 240 VAC input
	500 W at 240 VDC input for China only

Websites

General websites

Hewlett Packard Enterprise Information Library

www.hpe.com/info/EIL

Single Point of Connectivity Knowledge (SPOCK) Storage compatibility matrix

www.hpe.com/storage/spock

Storage white papers and analyst reports

www.hpe.com/storage/whitepapers

For additional general support websites, see [**Support and other resources**](#).

Product websites

Product QuickSpecs

<http://www.hpe.com/servers/ml30-gen10>

HPE ProLiant ML30 Gen10 support page

<http://www.hpe.com/support/ml30gen10>

HPE ProLiant ML30 Gen10 user documents

<http://www.hpe.com/info/ML30Gen10-docs>

Support and other resources

Accessing Hewlett Packard Enterprise Support

- For live assistance, go to the Contact Hewlett Packard Enterprise Worldwide website:
<https://www.hpe.com/info/assistance>
- To access documentation and support services, go to the Hewlett Packard Enterprise Support Center website:
<https://www.hpe.com/support/hpesc>

Information to collect

- Technical support registration number (if applicable)
- Product name, model or version, and serial number
- Operating system name and version
- Firmware version
- Error messages
- Product-specific reports and logs
- Add-on products or components
- Third-party products or components

ClearCARE technical support

Support for ClearOS and ClearVM is not provided by Hewlett Packard Enterprise. Support for ClearOS and ClearVM is purchased and delivered by ClearCenter. You can purchase single support incidents by submitting a support ticket to ClearCenter, or you can purchase a Bronze, Silver, Gold, or Platinum ClearCARE subscription. For more information, go to the ClearOS website:

<https://www.clearos.com/>

Several levels of professional technical support are available to licensed users. For more information, go to the ClearCARE support website:

<https://www.clearos.com/products/support/clearcare-overview>

Accessing updates

- Some software products provide a mechanism for accessing software updates through the product interface. Review your product documentation to identify the recommended software update method.
- To download product updates:

Hewlett Packard Enterprise Support Center

<https://www.hpe.com/support/hpesc>

Hewlett Packard Enterprise Support Center: Software downloads

<https://www.hpe.com/support/downloads>

Software Depot

<https://www.hpe.com/support/softwaredepot>

- To subscribe to eNewsletters and alerts:

<https://www.hpe.com/support/e-updates>

- To view and update your entitlements, and to link your contracts and warranties with your profile, go to the Hewlett Packard Enterprise Support Center **More Information on Access to Support Materials** page:

<https://www.hpe.com/support/AccessToSupportMaterials>

-
-  **IMPORTANT:** Access to some updates might require product entitlement when accessed through the Hewlett Packard Enterprise Support Center. You must have an HPE Passport set up with relevant entitlements.
-

Customer self repair

Hewlett Packard Enterprise customer self repair (CSR) programs allow you to repair your product. If a CSR part needs to be replaced, it will be shipped directly to you so that you can install it at your convenience. Some parts do not qualify for CSR. Your Hewlett Packard Enterprise authorized service provider will determine whether a repair can be accomplished by CSR.

For more information about CSR, contact your local service provider or go to the CSR website:

<http://www.hpe.com/support/selfrepair>

Remote support

Remote support is available with supported devices as part of your warranty or contractual support agreement. It provides intelligent event diagnosis, and automatic, secure submission of hardware event notifications to Hewlett Packard Enterprise, which will initiate a fast and accurate resolution based on your product's service level. Hewlett Packard Enterprise strongly recommends that you register your device for remote support.

If your product includes additional remote support details, use search to locate that information.

Remote support and Proactive Care information

HPE Get Connected

<https://www.hpe.com/services/getconnected>

HPE Proactive Care services

<https://www.hpe.com/services/proactivecare>

HPE Datacenter Care services

<https://www.hpe.com/services/datacentercare>

HPE Proactive Care service: Supported products list

<https://www.hpe.com/services/proactivecaresupportedproducts>

HPE Proactive Care advanced service: Supported products list

<https://www.hpe.com/services/proactivecareadvancedsupportedproducts>

Proactive Care customer information

Proactive Care central

<https://www.hpe.com/services/proactivecarecentral>

Proactive Care service activation

<https://www.hpe.com/services/proactivecarecentralgetstarted>

Documentation feedback

Hewlett Packard Enterprise is committed to providing documentation that meets your needs. To help us improve the documentation, send any errors, suggestions, or comments to Documentation Feedback (docsfeedback@hpe.com). When submitting your feedback, include the document title, part number, edition, and publication date located on the front cover of the document. For online help content, include the product name, product version, help edition, and publication date located on the legal notices page.

Acronyms and abbreviations

3DS TSV

three-dimensional stacked through-silicon via (integrated circuit packaging technology)

AHCI

advanced host controller interface

AHS

Active Health System

AHSV

Active Health System Viewer

API

application program interface

CAS

column address strobe

CSA

Canadian Standards Association

CSR

customer self repair

DDR4

double data rate-4

EMI shield

Electromagnetic shield

FC

Fibre Channel

FCoE

Fibre Channel over Ethernet

GPU

graphics processing unit

HBA

Host Bus Adapter

HPE SSA

HPE Smart Storage Administrator

IEC

International Electrotechnical Commission

iLO

Integrated Lights-Out

IML

Integrated Management Log

ISO

International Organization for Standardization

iSUT

Integrated Smart Update Tools

LFF

large form factor

LRDIMM

load reduced dual in-line memory module

LTO

linear tape-open

NMI

nonmaskable interrupt

NCSI

network controller sideband interface

PCA

printed circuit assembly

PCIe

Peripheral Component Interconnect Express

PCI

Peripheral Component Interconnect

PDU

power distribution unit

POST

Power-On Self-Test

PXE

Preboot eXecution Environment

RBSU

ROM-Based Setup Utility

RDIMM

registered dual in-line memory module

RPS

Redundant Power Supply

REACH

Registration, Evaluation, Authorization, Restriction of Chemicals (European Union chemical regulatory framework)

REST

representational state transfer

RoHS

Restriction of Hazardous Substances

SAS

serial attached SCSI

SATA

serial ATA

SFF

small form factor

STK

scripting toolkit

SPP

Service Pack for ProLiant

SSD

solid state device

SUM

Smart Update Manager

TMRA

recommended ambient operating temperature

TPM

Trusted Platform Module

UDIMM

unbuffered dual in-line memory module

UEFI

Unified Extensible Firmware Interface

UID

unit identification

UPS

uninterruptible power supply

VGA

Video graphics array