

INSTALLATION INSTRUCTIONS

FAN TRAY SYSTEM

FTA-3/FTA-6

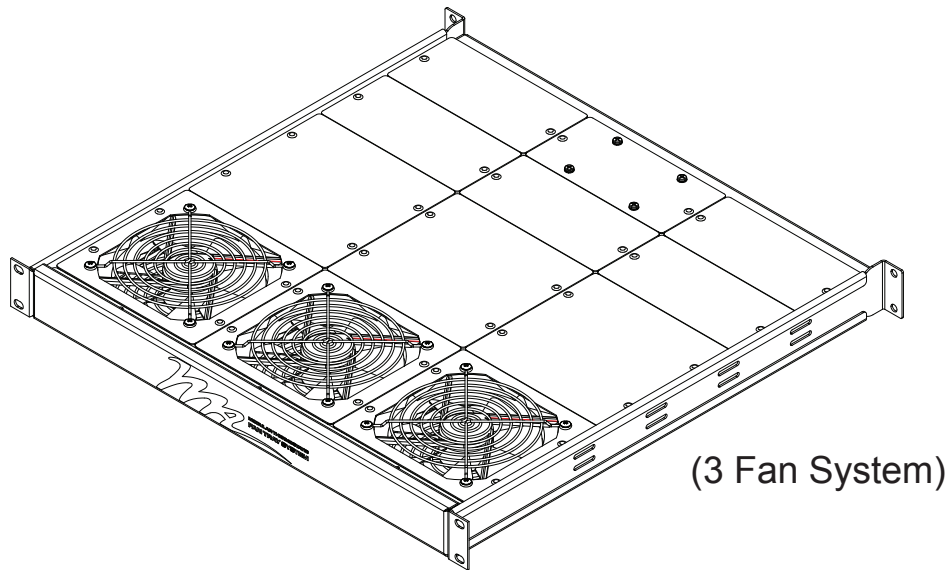

(3 Fan System)

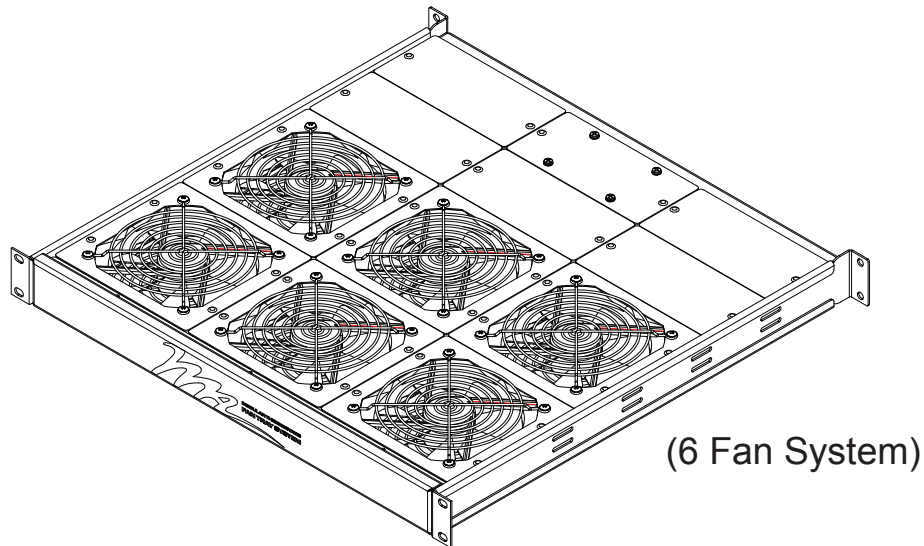

(6 Fan System)

THANK YOU

Thank you for purchasing the Fan Tray System. Please read these instructions thoroughly before installing this product

This Fan Tray is designed to work in conjunction with your overall thermal management system by moving hot air away from hot spots.

PRODUCT FEATURES

- Occupies one rackspace
- Fans can be placed anywhere on tray body, adjustable in half or full fan-width increments
- Adjustable depth allows fan tray to be adjusted from front to rear, 18" to 32" depth
- Energy-saving thermostatic control for automatic on/off when needed

FAN TRAY OPERATION

Versatile chassis allows fans to be located exactly where the heat is by mounting the chassis in the front or rear, and/or by moving fans within the grid provided.

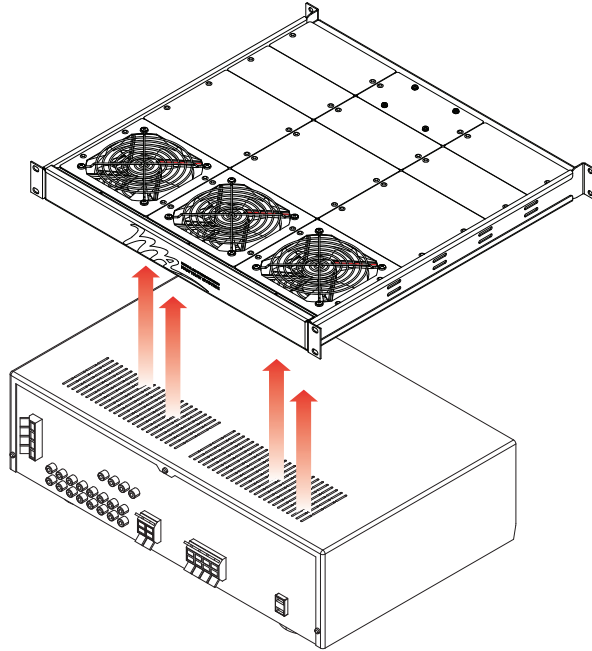

RELOCATION OF FANS AND CONTROL MODULE

After determining desired fan locations, adjust the positions of fans and panels as needed. Fans and panels are removable by pushing rivets out from bottom as shown. **(FIGURE A)**

NOTE: If a fan is needed in the same location as the fan controller, it can be relocated as needed. All spaces **MUST** be occupied by fans or filler panels to achieve proper thermal management

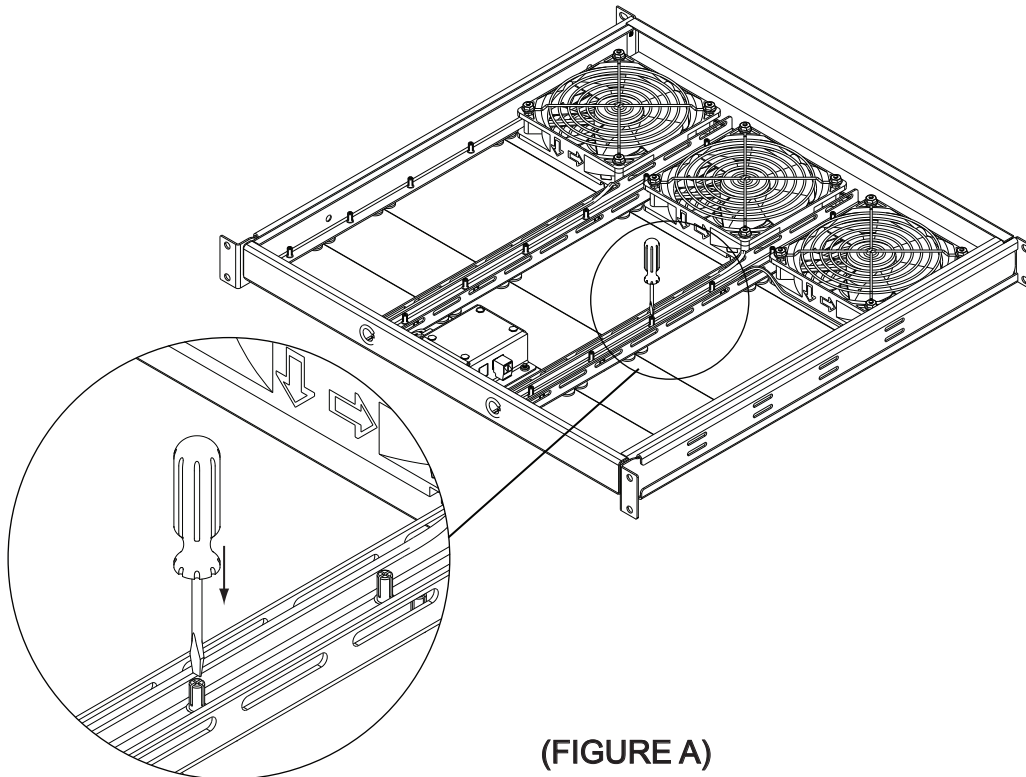

(FIGURE A)

FAN TRAY INSTALLATION

The Fan Tray can be installed in one of 2 orientations depending on heat source. **(FIGURE B)**

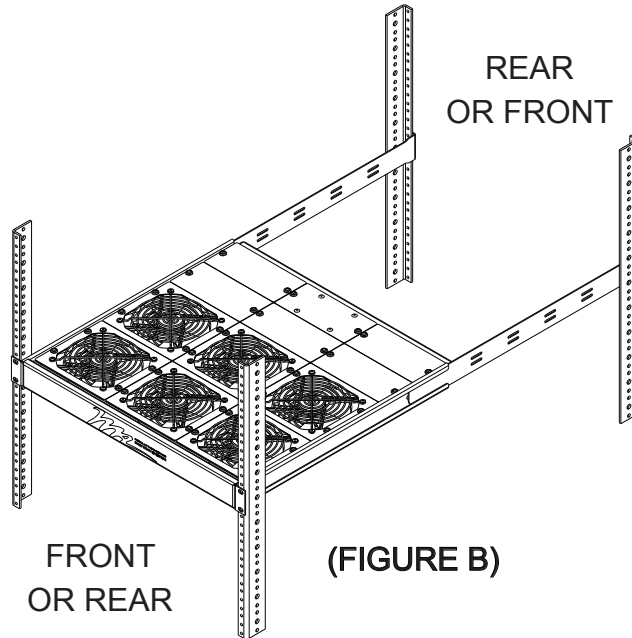

1) After determining the rackspace and direction in which you are mounting the fan tray, mount the support ears first using four 10-32 rack screws (four places). **(FIGURE C)**

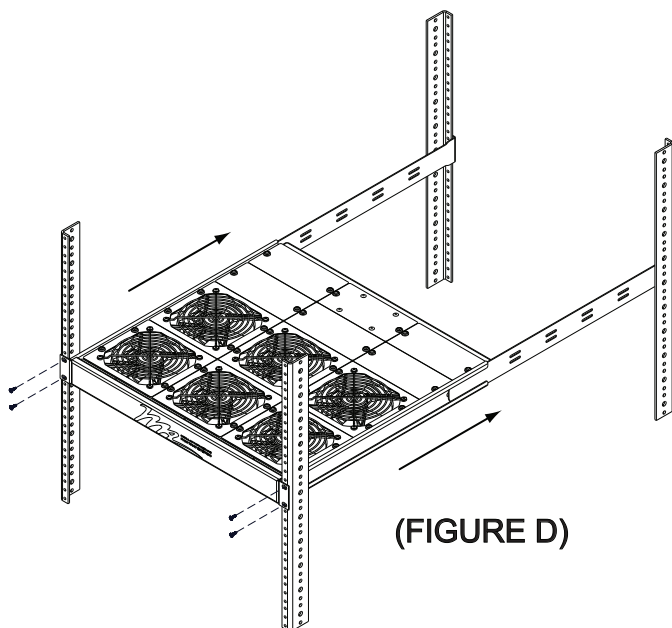
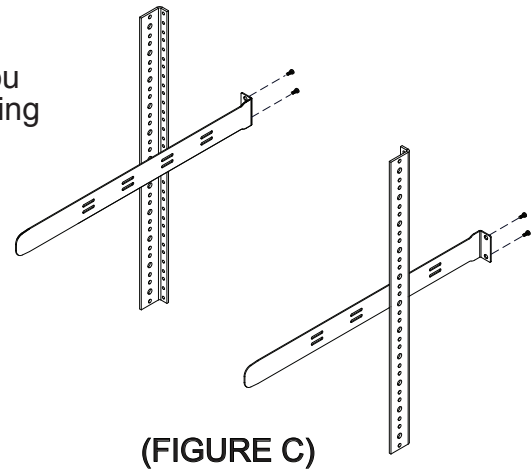

2) Slide the Fan Tray onto the ears from the other side, then add four 10-32 rack screws, securing the unit in place. **(FIGURE D)**

FAN CONTROL MODULE

Fans are pre-wired to Control Module as shown, labeled directly on top of Module. (FIGURE E)

NOTE: Location of wires to Control Module are specific to polarity which is shown on the top of the Module

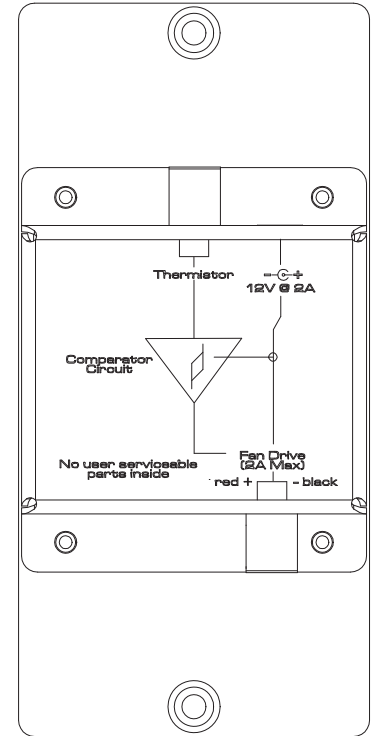
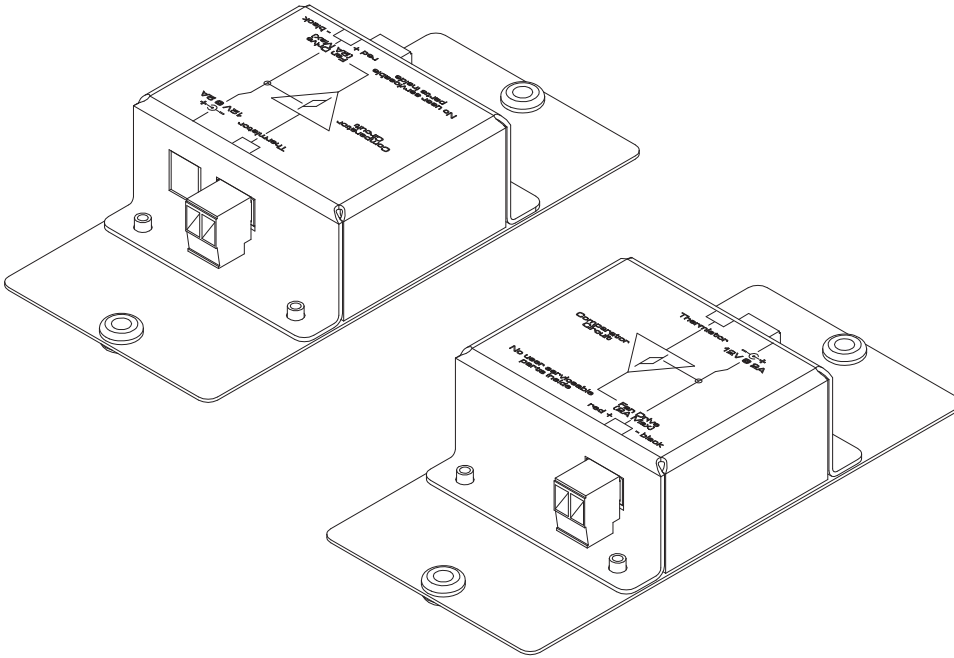

Top View

(FIGURE E)

“ALWAYS ON” FAN OPTION

To have your fan tray power run at all times (regardless of the temperature), remove the temperature probe/thermistor, and replace it with a bypass loop as shown. The unit will then run whenever it is connected to a power supply. Save temperature probe/thermistor for later use. (FIGURE F)

NOTE: If the tray is used in the rear of the rack to reduce static pressure, the temperature probe/thermistor should be placed near the top of the rack where the heat rises

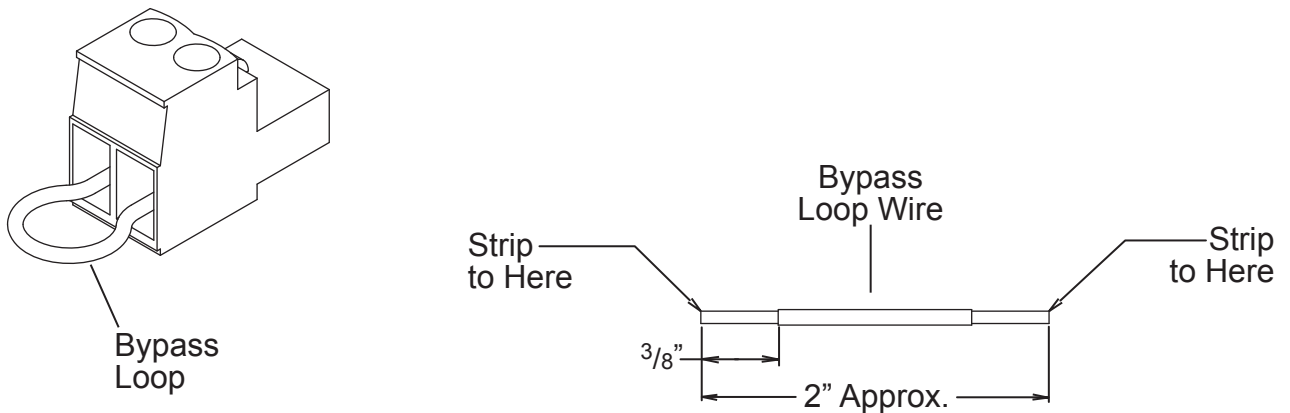

(FIGURE F)

OPTIONAL FAN KIT

Additional fans may be added to have a total of 8 fans in tray. Part Number: FT-FAN

NOTES

WARRANTY

Middle Atlantic Products, Inc. (the "Company") warrants the Fan Tray System to be free from defects in material or workmanship under normal use and conditions for three (3) years from the date of shipment from the company.

The Company's entire liability to the purchaser, and the purchaser's (or any other party's) sole and exclusive remedy, under this warranty shall be limited, at the Company's option, to either (a) return of and refund of the price paid for, or (b) repair or replacement at the Company's factory of the products purchased, or any part or parts thereof, which the Company has determined to be defective after inspection thereof at the Company's factory. This warranty does not cover damage due to acts of God, accident, misuse, abuse or negligence by parties other than the Company, or any modification or alteration of the products. In addition, this warranty does not cover damage due to improper handling, assembly, installation or maintenance.

THIS WARRANTY IS IN LIEU OF ALL OTHER WARRANTIES OF ANY KIND, EITHER EXPRESSED OR IMPLIED, INCLUDING, BUT NOT LIMITED TO, IMPLIED WARRANTIES OF MERCHANTABILITY AND FITNESS FOR A PARTICULAR PURPOSE.

TO THE MAXIMUM EXTENT PERMITTED BY APPLICABLE LAW, IN NO EVENT SHALL THE COMPANY BE LIABLE FOR ANY SPECIAL, INCIDENTAL, INDIRECT, OR CONSEQUENTIAL DAMAGES WHATSOEVER (INCLUDING, WITHOUT LIMITATION, DAMAGES FOR LOSS OF BUSINESS PROFITS, BUSINESS INTERRUPTION OR ANY OTHER PECUNIARY LOSS) ARISING OUT OF THE USE OF THE PRODUCTS PURCHASED, EVEN IF THE COMPANY HAS BEEN ADVISED OF THE POSSIBILITY OF SUCH DAMAGES. THE COMPANY'S LIABILITY TO THE PURCHASER (OR ANY OTHER PARTY) HEREUNDER, IF ANY, SHALL IN NO EVENT EXCEED THE PURCHASE PRICE OF THE PRODUCTS PAID TO THE COMPANY.

Corporate Headquarters

Corporate Voice 973-839-1011 - Fax 973-839-1976 / International Voice +1 973-839-8821 - Fax +1 973-839-4982
middleatlantic.com - info@middleatlantic.com

Middle Atlantic Canada

Voice 613-836-2501 - Fax 613-836-2690 / middleatlantic.ca - customerservicecanada@middleatlantic.ca

Factory Distribution

USA: NJ - CA - IL Canada: ON - BC

At Middle Atlantic Products we are always listening. Your comments are welcome.

Middle Atlantic Products is an ISO 9001 and ISO 14001 Registered Company.



30% Recycled Paper

