

# INSTALLATION INSTRUCTIONS

## SNE SERIES

### SNE-TCB-XX

- 1) Disconnect the bonding wire connected from the top to the enclosure.
- 2) Remove the top using a #2 Phillips drives. Each top section is secured with four screws. **(FIGURE A)**

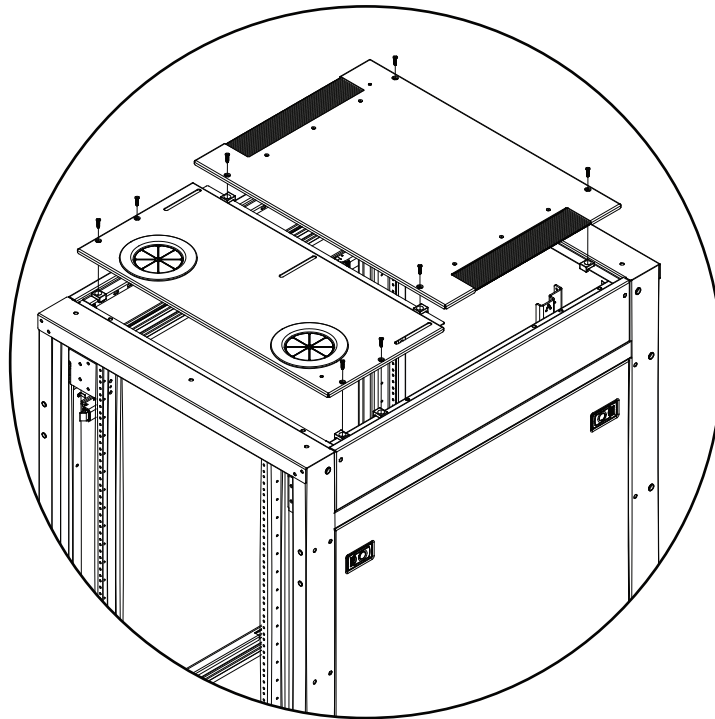

**FIGURE A**

- 3) Remove the desired quantity of the top side covers by removing the bolts (two per side) using a 5/16" wrench. **(FIGURE B)**

**NOTE:** You can remove one or both sides.

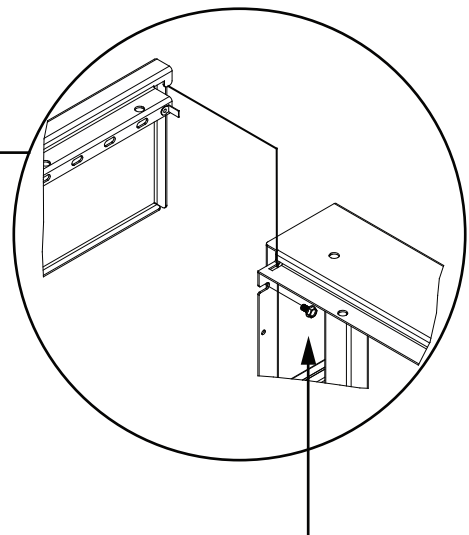
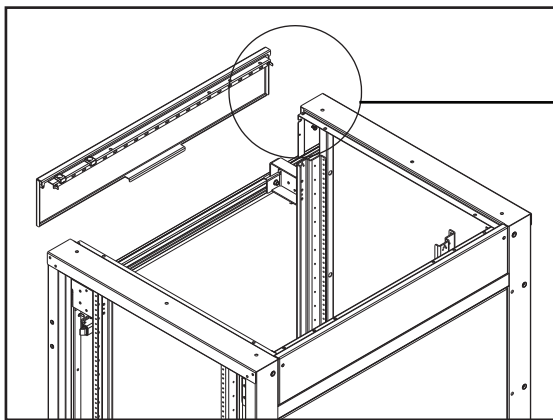

**BOLT**

**FIGURE B**

1) Install the cable pass-through sides as applicable using the previously removed bolts. **(FIGURE A)**

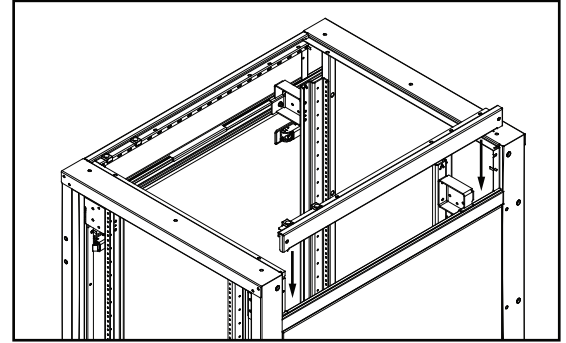

**NOTE:** There is multiple cable tie-points across the bottom flange on the bracket.

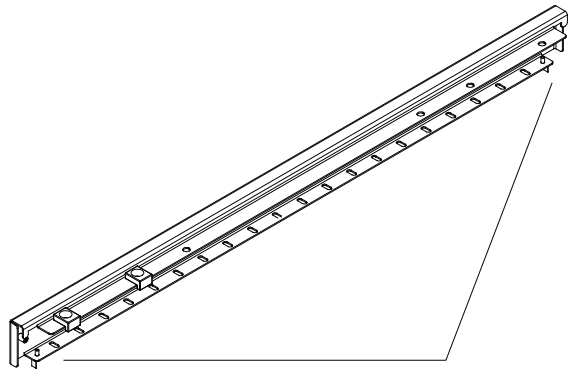

TIE-POINTS

#### **WARRANTY**

Middle Atlantic Products, Inc. (the "Company") warrants the SNE Series Top Options to be free from defects in material or workmanship under normal use and conditions for the lifetime of the product.

The Company's entire liability to the purchaser, and the purchaser's (or any other party's) sole and exclusive remedy, under this warranty shall be limited, at the Company's option, to either (a) return of and refund of the price paid for, or (b) repair or replacement at the Company's factory of the products purchased, or any part or parts thereof, which the Company has determined to be defective after inspection thereof at the Company's factory. This warranty does not cover damage due to acts of God, accident, misuse, abuse or negligence by parties other than the Company, or any modification or alteration of the products. In addition, this warranty does not cover damage due to improper handling, assembly, installation or maintenance.

THIS WARRANTY IS IN LIEU OF ALL OTHER WARRANTIES OF ANY KIND, EITHER EXPRESSED OR IMPLIED, INCLUDING, BUT NOT LIMITED TO, IMPLIED WARRANTIES OF MERCHANTABILITY AND FITNESS FOR A PARTICULAR PURPOSE.

TO THE MAXIMUM EXTENT PERMITTED BY APPLICABLE LAW, IN NO EVENT SHALL THE COMPANY BE LIABLE FOR ANY SPECIAL, INCIDENTAL, INDIRECT, OR CONSEQUENTIAL DAMAGES WHATSOEVER (INCLUDING, WITHOUT LIMITATION, DAMAGES FOR LOSS OF BUSINESS PROFITS, BUSINESS INTERRUPTION OR ANY OTHER PECUNIARY LOSS) ARISING OUT OF THE USE OF THE PRODUCTS PURCHASED, EVEN IF THE COMPANY HAS BEEN ADVISED OF THE POSSIBILITY OF SUCH DAMAGES. THE COMPANY'S LIABILITY TO THE PURCHASER (OR ANY OTHER PARTY) HEREUNDER, IF ANY, SHALL IN NO EVENT EXCEED THE PURCHASE PRICE OF THE PRODUCTS PAID TO THE COMPANY.

#### **Corporate Headquarters**

Corporate Voice 973-839-1011 - Fax 973-839-1976 / International Voice +1 973-839-8821 - Fax +1 973-839-4982  
middleatlantic.com - info@middleatlantic.com

#### **Middle Atlantic Canada**

Voice 613-836-2501 - Fax 613-836-2690 / middleatlantic.ca - customerservicecanada@middleatlantic.ca

#### **Factory Distribution**

USA: NJ - CA - IL Canada: ON - BC

**At Middle Atlantic Products we are always listening. Your comments are welcome.**

**Middle Atlantic Products is an ISO 9001 and ISO 14001 Registered Company.**