

INSTRUCTION SHEET

PET-K-FANTOP

BONDING KIT

THANK YOU

Thank you for purchasing the PET-K-FANTOP Bonding Kit. Please read these instructions thoroughly before installing this product.

HARDWARE/ITEMS SUPPLIED

ITEM	QTY
• Bonding Wire 12 Gauge (MMR)	(1)
• Bonding Wire 12 Gauge (QAR)	(1)
• Locking Nut 10-32	(1)
• Screw, 6-32 x 3/8"	(1)

INSTALLATION

Protective Earth Terminals (PET) are located in backpan of the wall rack. These terminals are marked with the symbol  Wall rack parts, center section and door, contain or are provided with bonding points for connection to the backpan / PET. Protective earth and bonding connections shall be in accordance with Article 250 of the National Electric Code.

1) **MMR:** Attach **bonding wire** (MMR) from bonding stud (10-32) on base to fan bonding point using hardware provided. **(FIGURE A, B)**

QAR: Attach **bonding wire** (QAR) to rackrail using one 6-32 x 3/8" screw. Attach other end to fan bonding point using hardware provided. **(FIGURE A)**

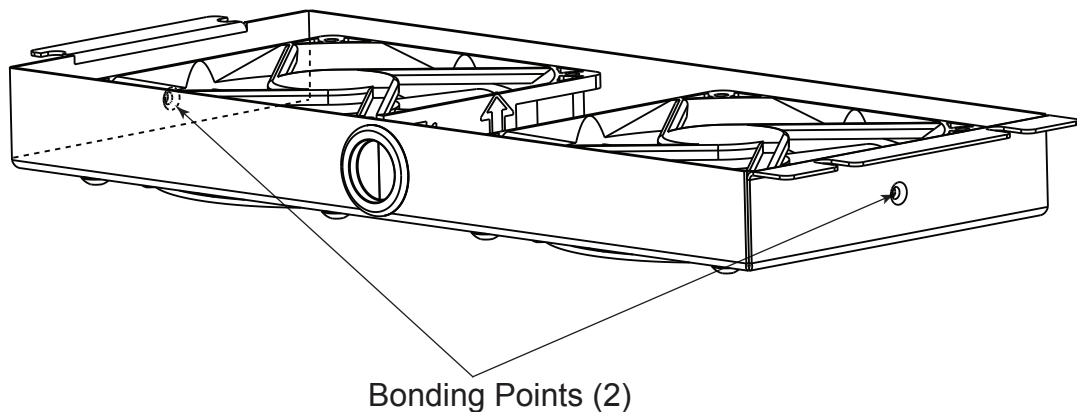
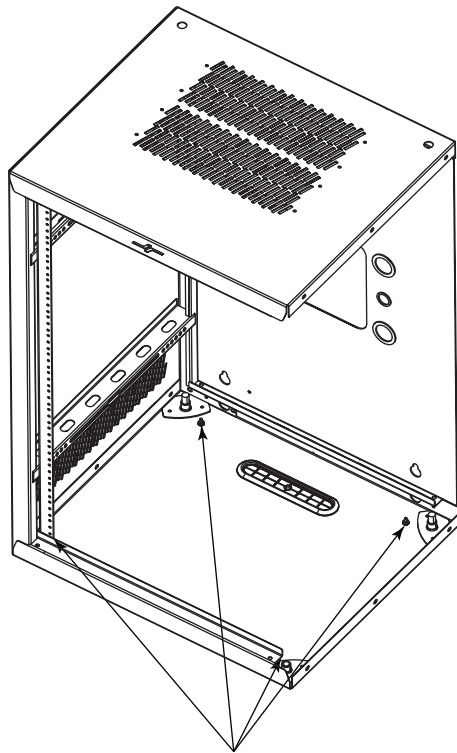

FIGURE A

INSTALLATION (Continued)



Bonding Studs (4) 10-32

Protective Earth
Terminal
(PET) 10-32

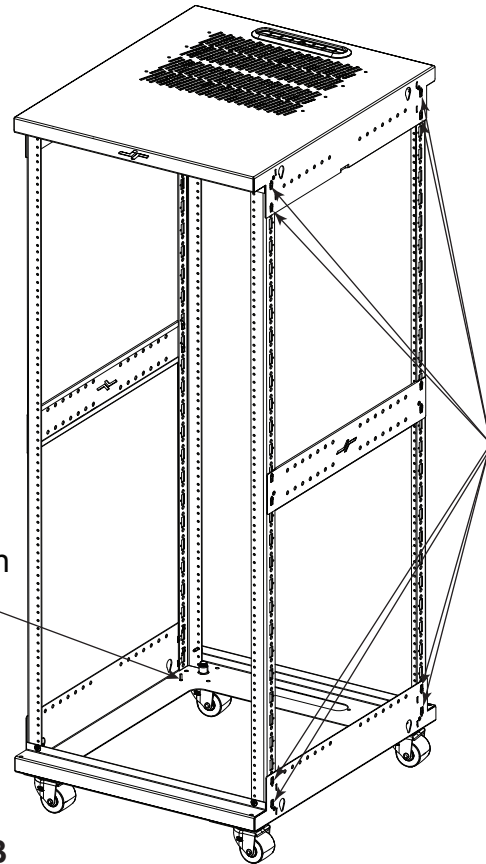

Rackrail
Bonding
Points
(4) 10-32

FIGURE B

WARRANTY

Middle Atlantic Products (the "Company") warrants the PET-K-FANTOP to be free from defects in material or workmanship under normal use and conditions for the lifetime of the product.

The Company's entire liability to the purchaser, and the purchaser's (or any other party's) sole and exclusive remedy, under this warranty shall be limited, at the Company's option, to either (a) return of and refund of the price paid for, or (b) repair or replacement at the Company's factory of the products purchased, or any part or parts thereof, which the Company has determined to be defective after inspection thereof at the Company's factory.

This warranty does not cover damage due to acts of God, accident, misuse, abuse or negligence by parties other than the Company, or any modification or alteration of the products. In addition, this warranty does not cover damage due to improper handling, assembly, installation or maintenance.

THIS WARRANTY IS IN LIEU OF ALL OTHER WARRANTIES OF ANY KIND, EITHER EXPRESSED OR IMPLIED, INCLUDING, BUT NOT LIMITED TO, IMPLIED WARRANTIES OF MERCHANTABILITY AND FITNESS FOR A PARTICULAR PURPOSE.

TO THE MAXIMUM EXTENT PERMITTED BY APPLICABLE LAW, IN NO EVENT SHALL THE COMPANY BE LIABLE FOR ANY SPECIAL, INCIDENTAL, INDIRECT, OR CONSEQUENTIAL DAMAGES WHATSOEVER (INCLUDING, WITHOUT LIMITATION, DAMAGES FOR LOSS OF BUSINESS PROFITS, BUSINESS INTERRUPTION OR ANY OTHER PECUNIARY LOSS) ARISING OUT OF THE USE OF THE PRODUCTS PURCHASED, EVEN IF THE COMPANY HAS BEEN ADVISED OF THE POSSIBILITY OF SUCH DAMAGES. THE COMPANY'S LIABILITY TO THE PURCHASER (OR ANY OTHER PARTY) HEREUNDER, IF ANY, SHALL IN NO EVENT EXCEED THE PURCHASE PRICE OF THE PRODUCTS PAID TO THE COMPANY.

Corporate Headquarters

Corporate Voice 973-839-1011 - Fax 973-839-1976 / International Voice +1 973-839-8821 - Fax +1 973-839-4982
middleatlantic.com - info@middleatlantic.com

Middle Atlantic Canada

Voice 613-836-2501 - Fax 613-836-2690 / middleatlantic.ca - customerservicecanada@middleatlantic.ca

Factory Distribution

USA: NJ - CA - IL Canada: ON - BC

At Middle Atlantic Products we are always listening. Your comments are welcome.

Middle Atlantic Products is an ISO 9001 and ISO 14001 Registered Company.