



Cisco NCS 4206 Hardware Installation Guide

First Published: 2016-08-01

Last Modified: 2024-04-07

Americas Headquarters

Cisco Systems, Inc.
170 West Tasman Drive
San Jose, CA 95134-1706
USA
<http://www.cisco.com>
Tel: 408 526-4000
800 553-NETS (6387)
Fax: 408 527-0883



CONTENTS

CHAPTER 1

Cisco NCS 4206 Overview 1

Cisco NCS 4206 Features 1

Power Supply Features 3

Redundancy 3

Status LEDs 3

DC Power Specifications 3

Fan Tray 4

Fan Tray (A903-FAN-H) 4

Plenum 5

RSP Modules 6

Supported RSPs 6

Supported Interface Modules 7

Supported RSP Features 9

RSP Redundancy 9

Network Timing Interfaces 9

RSP Interfaces 9

Power Supply Features 11

Interface Modules 11

8-port 10 Gigabit Ethernet Interface Module (8X10GE) 11

1-port 100 Gigabit Ethernet Interface Module (1X100GE) 11

2-Port 100 Gigabit Ethernet Interface Module (2X100GE) 12

8x1 Gigabit Ethernet SFP + 1x10 Gigabit Ethernet SFP+ Combination Interface Module 13

2-port 40 Gigabit Ethernet QSFP Interface Module (2X40GE) 13

1-port OC-192 or 8-port Low Rate CEM Interface Module (10G HO / 10G LO) 13

NCS 4200 1-Port OC-192 or 8-Port Low Rate CEM 20G Bandwidth Interface Module (NCS4200-1T8S-20CS)	15
8/16-Port 1 Gigabit Ethernet (SFP / SFP) + 1-port 10 Gigabit Ethernet (SFP+) / 2-port 1 Gigabit Ethernet (CSFP) Interface Module	17
1-Port OC48/ STM-16 or 4-port OC-12/OC-3 / STM-1/STM-4 + 12-port T1/E1 + 4-Port T3/E3 CEM Interface Module	18
48-port T1/E1 CEM Interface Module	19
48-port T3/E3 CEM Interface Module	20
8-port T1/E1 Interface Module (A900-IMA8D)	20
Temperature Sensor	21
Temperature Sensors on the RSP modules	21
Patch Panels	21
Interface Numbering	24
Regulatory Compliance	25

CHAPTER 2
Preparing for Installation 27

Safety Guidelines	27
Standard Warning Statements	27
Safety Guidelines for Personal Safety and Equipment Protection	30
Safety Precautions for Module Installation and Removal	30
Safety with Electricity	31
Power Supply Considerations	36
Preventing ESD Damage	36
Site Planning	37
General Precautions	37
Site Planning Checklist	37
Site Selection Guidelines	37
Environmental Requirements	38
Physical Characteristics	38
Air Flow Guidelines	38
Air Flow Guidelines for Enclosed Rack Installation	40
Floor Loading Considerations	40
Site Power Guidelines	40
Electrical Circuit Requirements	42

Site Cabling Guidelines	42
Asynchronous Terminal Connections	43
Interference Considerations	43
Rack-Mounting Guidelines	43
Precautions for Rack-Mounting	44
Rack Selection Guidelines	44
Equipment Rack Guidelines	44
Installation Checklist	45
Creating a Site Log	46
Receiving the Cisco NCS 4206	46
Chassis-Lifting Guidelines	47
Tools and Equipment	48
Unpacking and Verifying the Shipped Contents	49

CHAPTER 3**Installing the Cisco NCS 4206 51**

Prerequisites	51
Installing the Chassis in a Rack	51
Installing the Chassis Brackets	51
Installing the Chassis in the Rack	53
Installing the Chassis with Plenum in Rack	55
Installing the Chassis in the Air Plenum	59
Installing the Chassis Ground Connection	60
Installing the Fan Tray	62
Installing the Dust Filter	63
Removing the Dust Filter	64
Dust Filter Maintenance	64
Removing and Replacing the Fan Tray	64
RSP Installation	67
Installing an RSP Module	67
Removing an RSP Module	69
Installing the Wire Wrap Adapter	70
Hot-Swapping an RSP Module	70
Interface Module Installation	71
Installing an Interface Module	71

Removing an Interface Module	72
Hot-Swapping an Interface Module	73
Installing the Power Supply	74
Preventing Power Loss	75
Power Connection Guidelines	75
Guidelines for DC-Powered Systems	75
Installing the DC Power Supply	76
Installing the DC Power Supply Module	76
Connecting DC Power Supply Unit (A900-PWR900-D2)	77
Activating the DC Power Supply	79
Removing and Replacing the DC Power Supply	79
Installing the AC power Supply	80
Installing the AC Power Supply Module for A900-PWR550-A (550 W) and A900-PWR1200-A (1200 W)	80
Recommended Power Cables	81
Activating the AC Power Supply	83
Power Cable Bracket (A9XX-PWR-CBL-MGMT)	83
Top Cable Management Bracket (A9XX-TOP-CBL-MGMT)	85
Connecting the Cisco NCS 4206 to the Network	87
Connecting Console Cables	87
Connecting to the Serial Port using Microsoft Windows	87
Connecting to the Console Port using Mac OS X	88
Connecting to the Console Port using Linux	89
Installing the Cisco Microsoft Windows USB Device Driver	89
Uninstalling the Cisco Microsoft Windows USB Driver	91
Connecting to the Auxiliary Port	92
Connecting a Management Ethernet Cable	94
Installing and Removing SFP Modules	94
Connecting a USB Flash Device	94
Removing a USB Flash Device	95
Connecting Timing Cables	95
Connecting Cables to the BITS Port using the Wire Wrap Interface	95
Connecting Cables to a GNSS Interface	96
Connecting Ethernet Cables	97

Connecting Cables to SFP Modules	98
Connecting T1/E1 Cables	98
Installing the Cable Connectors	99
Patch Panel Cables	99
Connecting Cables to the Patch Panel	100
Patch Panel Connectors	101
Patch Panel Cabling for Redundancy	101
RJ45 Cable Pinouts	103
Installing Patch Panel	103
Ground Connection for Patch Panel	112
Install 3G Patch Panel	113
Install Rack Brackets	113
Set up 3G Patch Panel on Rack	121
Wall Mount 3G Patch Panel	133
Patch Panel Dimensions	135
Patch Panel Pinout	139
Panel and Bracket	140
Connecting the Fan Tray Alarm Port	140
Connector and Cable Specifications	141
<hr/>	
CHAPTER 4	Cisco NCS 4206 Initial Configuration 143
	Checking Conditions Prior to System Startup 143
	Powering Up the Cisco NCS 4206 144
	Verifying the Front Panel LEDs 144
	Verifying the Hardware Configuration 144
	Checking Hardware and Software Compatibility 145
	Configuring the Cisco NCS 4206 at Startup 145
	Using the Console Interface 145
	Configuring Global Parameters 146
	Checking the Running Configuration Settings 147
	Saving the Running Configuration to NVRAM 147
	Safely Powering Off the Cisco NCS 4206 148
<hr/>	
CHAPTER 5	Troubleshooting 149

Pinouts	149
BITS Port Pinout	149
Wire Wrap Adapter Pinouts	150
GPS Port Pinout	150
Time of Day Port Pinout	150
Alarm Port Pinout	151
Console/Aux RJ45 RS232 Serial Port Pinout	152
8 T1/E1 Interface Module RJ48C Port Pinnouts	152
T1/E1 Port Pinout	153
RJ48 T1/E1 Port Pinouts	153
AMP64 Pinouts	154
Management Ethernet Port Pinout	159
USB Console Port Pinout	160
USB Flash/MEM Port Pinout	160
Fiber-Optic Specifications	161
Cabling Guidelines	161
LED Summary	162
RSP LEDs	162
NCS420X-RSP LED	162
NCS420X-RSP LED Fault Condition	163
Interface Module LEDs	164
OC-192 Interface Module + 8-Port Low Rate Interface Module LEDs	164
48 T1/E1 and 48 T3/E3 Interface Module LEDs	165
8-port 10 Gigabit Ethernet Interface Module LEDs	166
1-port 100 Gigabit Ethernet Interface Module LEDs	166
2-port 40 Gigabit Ethernet Interface Module LEDs	167
Power Supply LEDs	168
Fan Tray LEDs	168
Alarm Conditions	169
APPENDIX A	
Site Log and Manufactures	171
Manufactures	172



CHAPTER 1

Cisco NCS 4206 Overview

The Cisco NCS 4206 is a fully-featured aggregation platform designed for the cost-effective delivery of converged mobile and business services. With shallow depth, low power consumption, and an extended temperature range, this compact 3-rack-unit (RU) chassis provides high service scale, full redundancy, and flexible hardware configuration.

The Cisco NCS 4206 expands the Cisco service provider product portfolio by providing a rich and scalable feature set of Layer 2 VPN (L2VPN) and Layer 3 VPN (L3VPN) services in a compact package. It also supports a variety of software features, including Carrier Ethernet features, Timing over Packet, and pseudowire.

The Cisco NCS 4206 is positioned as a pre-aggregation chassis in IP RAN (GSM, UMTS, iMAX, CDMA, and LTE) networks or an aggregation chassis in Carrier Ethernet networks.

- [Cisco NCS 4206 Features, on page 1](#)
- [Interface Numbering, on page 24](#)
- [Regulatory Compliance, on page 25](#)

Cisco NCS 4206 Features

The Cisco NCS 4206 has the following hardware features:

- 3-RU modular chassis designed for installation in a 23-inch EIA rack
- Dedicated slots in the chassis that support the following:
 - Up to six interface modules
 - Up to two Route Switch Processors (RSP)
 - Up to two DC power supply units
 - One fan tray
- Network frequency, phase, and time inputs and outputs for network interfaces (SyncE and TDM), BITS, 1 PPS or 10 MHz and Timing over Packet (IEEE 1588-2008)
- Adjustable front and rear rail mounting locations
- Front panel access to power supplies, fan tray, RSPs, and interface modules
- Online insertion and removal (OIR) of RSP, interface modules, power supplies, and fan tray
- Discrete status LEDs on power supply, interface module, RSP, and fan tray units
- Four alarm dry contact inputs (either normally open or normally closed)
- Environmental monitoring and reporting functions
- LED indicators for critical, major, and minor alarms

- Side-to-side forced air cooling

Figure 1: Cisco NCS 4206 Chassis with Door

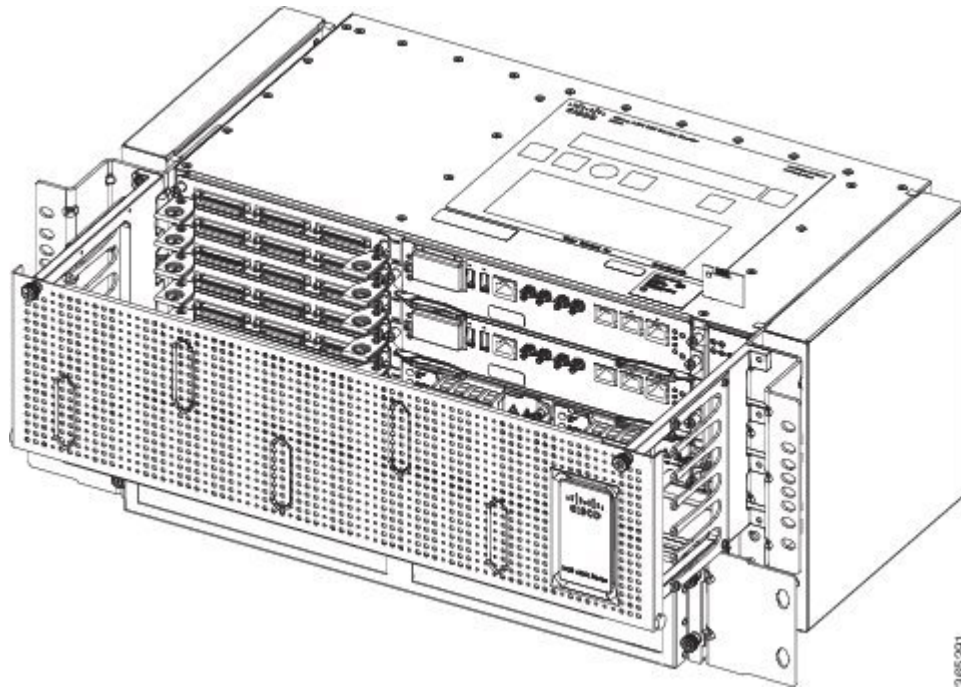

The figure below illustrates the Cisco NCS 4206 chassis design.

Figure 2: Cisco NCS 4206 Chassis Design

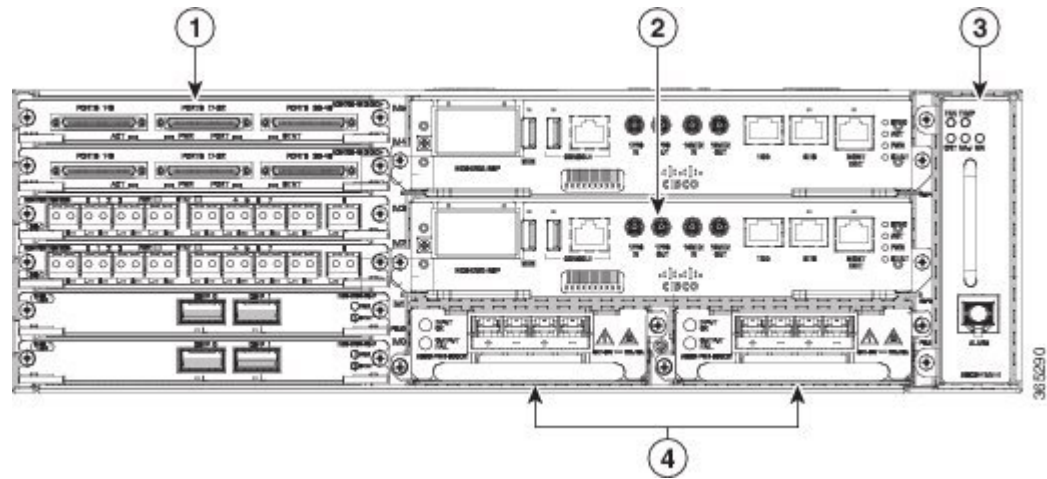

1	Interface modules
2	RSP unit
3	Fan tray
4	Redundant power units (two DC power units are shown)

Power Supply Features

The Cisco NCS 4206 support DC power supplies. For more information about installing the Cisco NCS 4206 power supplies, see [Installing the Power Supply](#).

To estimate the required power supply, use the [Cisco Power Calculator](#).

The power sections provide more information about the power supply.

Redundancy

The Cisco NCS 4206 chassis includes a slot for an optional redundant power supply. The redundant power supply option provides a second power supply to ensure that power to the chassis continues uninterrupted if one power supply fails or input power on one line fails. Redundancy is supported either with identical power supplies or a combination of DC power supply. The Cisco NCS 4206 supports current sharing between the power supplies.

If you install a redundant power supply on the Cisco NCS 4206, we recommend that you connect each power supply to a separate input power source in order to ensure that the chassis maintains power in the event of a power interruption caused by an electrical failure, a wiring fault, or a tripped circuit breaker.

Status LEDs

LEDs are also provided on each power supply to indicate the status of the input power and the health of the power supply. For more information about the LEDs on the Cisco NCS 4206, see [Pinouts](#).

DC Power Specifications

The power supply contains a front panel with mounting screws, a handle for insertion and removal, and two status LEDs. No ON/OFF switch is provided. The power supply is field replaceable and hot-swappable.

The DC power supply model supported on the chassis is:

- A900-PWR900-D2—Provides 900 W output power for system. See the figure below.

Figure 3: A900-PWR900-D2 DC Power Supply

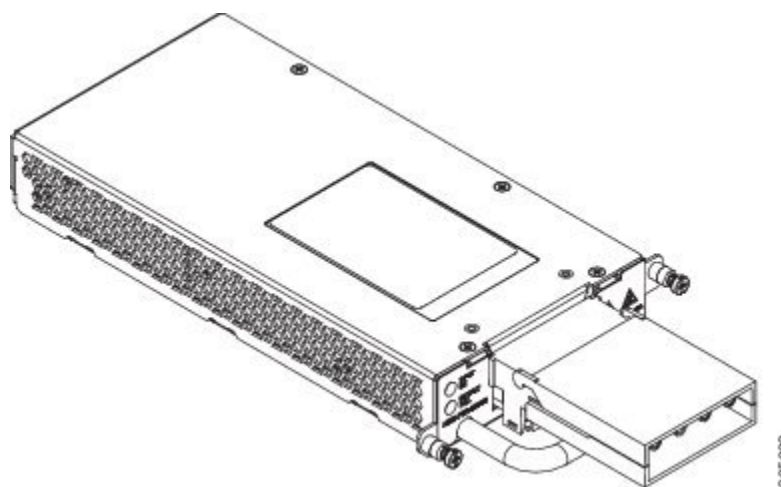

The A900-PWR900-D2 DC power supply module comes with a protective front cover.

Table 1: DC Power Supply Specifications (A900-PWR900-D2)

Part numbers	A900-PWR900-D2
Input power specification	48V, GND, -48V
Minimum input voltage	-40.0 V
Maximum input voltage	-72 VDC
Input current specification	22A @-48VDC 18A @-60VDC
Output voltage	+12 VDC
Wire gauge for DC input power connections	6 or 8 or 10 AWG for -48/-60 VDC
Maximum power output	900 W

For more information on installing the power supply, see [Connecting DC Power Supply Unit \(A900-PWR900-D2\)](#).

Fan Tray

The fan tray has the following hardware features:

- It provides side-to-side forced air cooling
- It is field replaceable
- It contains status LEDs
- It contains an alarm port with four external alarm inputs

The fan tray module supported on the chassis is:

- A903-FAN-H

For more information about air flow guidelines, see [Air Flow Guidelines](#). For instructions on how to install the fan tray, see [Installing the Fan Tray](#). For a summary of the LEDs on the fan tray, see [LED Summary](#).

Fan Tray (A903-FAN-H)

The Cisco NCS 4206 uses a modular fan tray that is separate from the power supply. The fan tray contains twelve fans and provides sufficient capacity to maintain operation indefinitely in the event of an individual fan failure.

Figure 4: Cisco NCS 4206 Fan Tray (A903FANH)

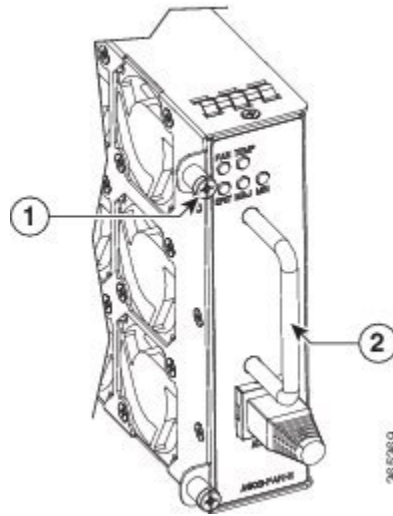

1	Fan tray screw	2	Handle
---	----------------	---	--------

Plenum

Plenum or air baffle assembly (see the figure below) is used to change the air flow pattern of the unit. When the chassis is installed with the plenum, the air flow pattern is changed from side-side to front-back. The air flow front-back pattern provides a rack installation bay with a cool front zone and hot rear zone. For installing the plenum, see [Installing the Chassis in the Air Plenum](#).

Figure 5: Chassis in Plenum

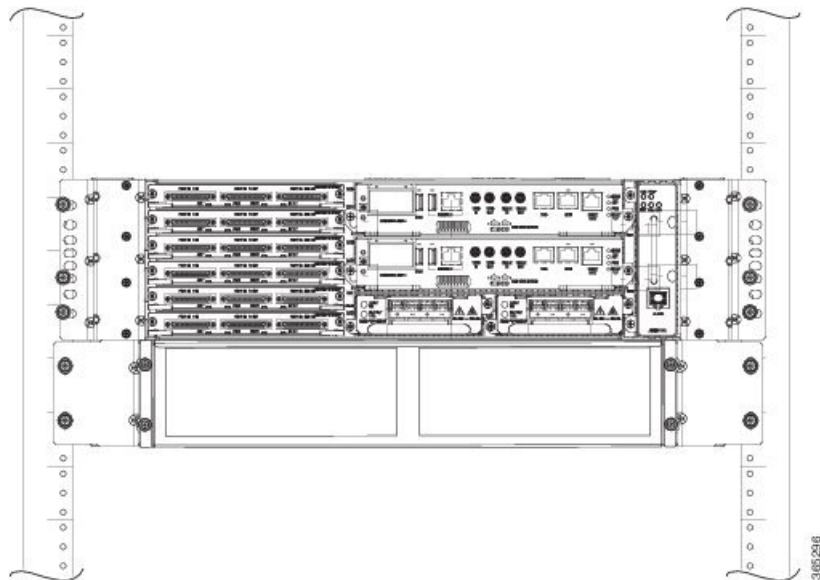



Note When the plenum and air filter are installed in the chassis, the system operating temperature is 55 degrees Celsius.

The air filter must be removed for cleaning or for a replacement.

Air Filter Maintenance

A periodic health check of the filter, every 3 months based on the level of dust in the environment helps in avoiding over clogging of the filters and provide better life. The filter may be used as a single use or reused depending upon the local deployment needs. If reuse of the filter is prohibited, it may be replaced every six months.

If reused, this filter media may be cleaned with slightly compressed air, vacuumed, and/or rinsed with clean water. If a degreaser is required, use only a mild detergent, such as, dish washing liquid.



Caution Avoid using harsh solvents or cleaning agents.

If filter is cleaned with water, the filter should be completely dry before reinstalling. Even though this type of filter may be cleaned, replacement is recommended every two to three years to ensure media durability and eliminate residual dust build-up and subsequent air flow resistance.

RSP Modules

The Cisco NCS 4206 is designed to use up to two RSP modules to handle the data plane, network timing, and control plane functionalities for the chassis. The RSP configuration allows you to use Cisco IOS software to control chassis management, redundancy, external management, and system status indications on the chassis.

RSP features include:

- Loading software onto processor-based interface modules
- Redundant RSP management—The RSP manages detection of RSPs, exchange of health and status information, role negotiation, function for detection, health and status exchange, role negotiation
- Packet processing
- Traffic management, including buffering, queuing, and scheduling, Ethernet MAC functions
- Network clocking functions including phase and time-of-day for BITS, 1 PPS, 10 MHz, and 1588 PTP clock references
- Storage of software images, system configuration, OBFL, SysLog
- PTP packet processing including IEEE 1588-2008 for recovering network timing (frequency, phase, and time) from upstream PTP clocks, for generating PTP frequency and phase references as inputs to the SETS, and for distributing them to downstream PTP clocks
- External management interfaces (RS232 console, management ENET, USB console, USB storage) and system status LED indicators

Supported RSPs

The Cisco NCS 4206 supports the following RSP module:

- NCS420X-RSP—Provides 8 GB DDR3 memory, 64MB flash memory, 20 Mb of TCAM memory, 400 Gbps throughput, and a USB port for mass storage on the faceplate.

- NCS4206-RSP—Provides 4 GB double data rate type three (DDR3) memory, 128 Gbps aggregate throughput.

The RSP modules do not provide external network interfaces for user traffic. All network interfaces are provided via separate interface modules.

Figure 6: NCS420X-RSP RSP Module

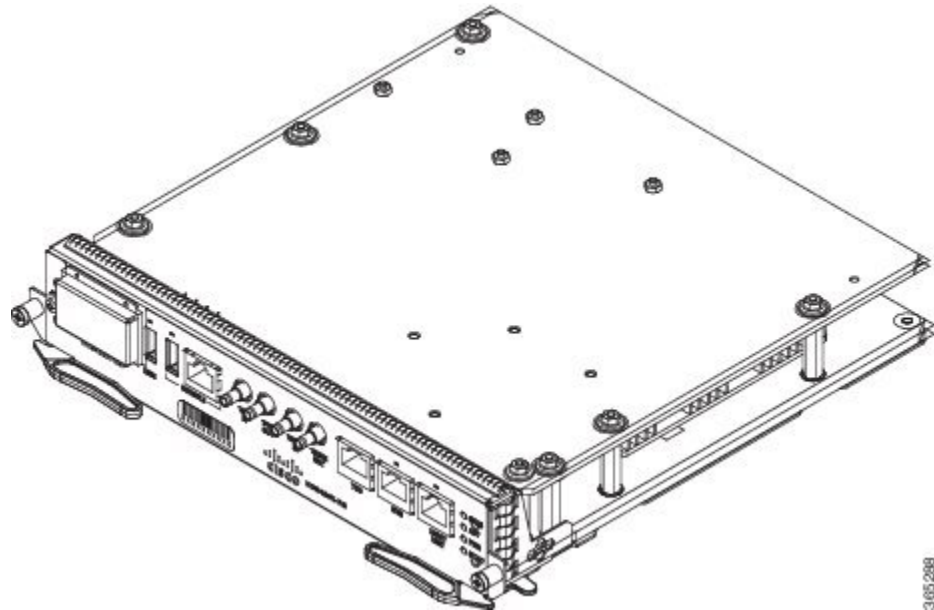

Note If there is any silicon oil leakage from the thermal pad of the NCS420X-RSP card, use a lint-free cloth moistened with IsoPropyl Alcohol (IPA) to thoroughly clean the affected area. Silicon oil leakage is an expected behaviour due to the material's properties. It is non-conductive, non-electrical, and poses no hazard to human health. The presence of silicon oil on the card is harmless and will not impact the card's functionality or system performance.

Supported Interface Modules



Note If the **license feature service-offload enable** command is configured, then the NCS4200-1T8LR-PS IM is not supported in the router for RSP3.



Note There are certain restrictions in using the interface modules on different slots in the chassis. Contact Cisco Sales/Support for the valid combinations.



Note FAN OIR is applicable every time the IM based fan speed profile is switched to NCS4200-1H-PK= and NCS4200-2Q-P interface modules. Even though the IMs remain in the Out-of-Service state, they are still considered as present in the chassis.

Table 2: NCS420X-RSP Supported Interface Modules and Part Numbers

RSP Module	Supported Interface Modules	Part Numbers	Slot
NCS420X-RSP	8-port 10 Gigabit Ethernet Interface Module (8X10GE)	NCS4200-8T-PS	All
	1-port 100 Gigabit Ethernet Interface Module (1X100GE)	NCS4200-1H-PK=	4 and 5
	2-port 40 Gigabit Ethernet QSFP Interface Module (2X40GE)	NCS4200-2Q-P	4 and 5
	8/16-port 1 Gigabit Ethernet (SFP/SFP) + 1-port 10 Gigabit Ethernet (SFP+) / 2-port 1 Gigabit Ethernet (CSFP) Interface Module	NCS4200-1T16G-PS	0,3,4, and 5
	1-port OC-192 Interface module or 8-port Low Rate Interface Module	NCS4200-1T8S-10CS	2,3,4, and 5
	NCS 4200 1-Port OC-192 or 8-Port Low Rate CEM 20G Bandwidth Interface Module	NCS4200-1T8S-20CS	2,3,4, and 5 ¹
	48-port T1/E1 CEM Interface Module	NCS4200-48T1E1-CE	All
	48-port T3/E3 CEM Interface Module	NCS4200-48T3E3-CE	All
	2-port 100 Gigabit Ethernet (QSFP) Interface Module (2X100GE) ²	NCS4200-2H-PQ	4,5
	1-port OC48 ³ / STM-16 or 4-port OC-12/OC-3 / STM-1/STM-4 + 12-port T1/E1 + 4-Port T3/E3 CEM Interface Module	NCS4200-3GMS	2,3,4, and 5

¹ These slots are supported on 10G or 20G mode.

² IM supports only one port of 100G with RSP3 as QSFP28 on Port 0 in both slots 4 and 5.

³ If OC48 is enabled, then the remaining 3 ports are disabled.

Table 3: NCS420X-RSP-128 Supported Interface Modules and Part Numbers

RSP Module	Supported Interface Modules	Part Numbers	Slot
NCS420X-RSP	SFP Combo IM—8-port Gigabit Ethernet (8X1GE) + 1-port 10 Gigabit Ethernet Interface Module (1X10GE)	NCS4200-1T8LR-PS	All
	8-port T1/E1 CEM Interface Module	NCS4200-8E1T1-CE	All
	1-port OC48 ⁴ / STM-16 or 4-port OC-12/OC-3 / STM-1/STM-4 + 12-port T1/E1 + 4-Port T3/E3 CEM Interface Module	NCS4200-3GMS	2,3,4, and 5

⁴ If OC48 is enabled, then the remaining 3 ports are disabled.

Supported RSP Features

The RSP provides the following features:

- Centralized data plane, timing, and control plane functions for the system.
- High-level control of interface modules.
- Management functionalities for the chassis.
- Control plane (host) CPU and associated memory in which IOS-XE and platform control software runs.
- Nonvolatile memory for storage of software images, configurations, and system files.
- Enabling and monitoring the health and presence of fan trays, interface modules, and power supplies.
- Field replacement and hot-swap capabilities.

RSP Redundancy

The Cisco NCS 4206 chassis includes two RSP slots to allow for redundant RSPs. When the chassis uses redundant RSPs, one RSP operates in the active mode and the other operates in the hot standby mode. Removal or failure of the active RSP results in an automatic switchover to the standby RSP.

Network Timing Interfaces

The RSP supports the following network timing interfaces:

- BITS input/output port—RJ48 jack
- 1 PPS input and output—Mini coax connectors
- 2.048 or 10 MHz input and output—Mini coax connectors
- Time of Day (ToD) or input/output port and 1 PPS input port—Shielded RJ45 jack

Network timing interfaces support redundancy in a redundant RSP configuration. Network timing interfaces on a redundant RSP remain in operation while the RSP is in hot standby mode.

RSP Interfaces

The figure below summarizes the interfaces on the RSP module.

Figure 7: RSP Interface Summary

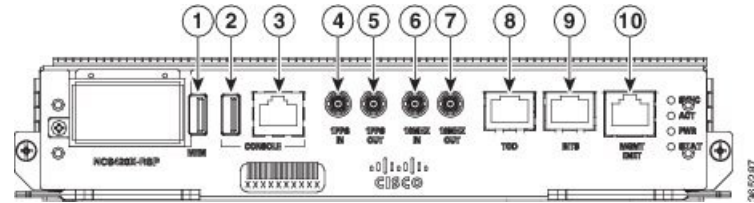
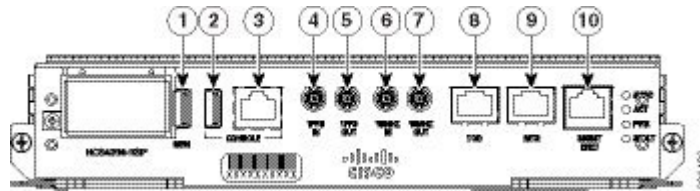

Figure 8: NCS4206-RSP Interface Summary



Label	Interface
1	USB memory port
2	USB console port
3	Console port
4	1 PPS input timing port
5	1 PPS output timing port
6	10 MHz input timing port
7	10 MHz output timing port
8	Time of Day (ToD) timing port
9	BITS timing port
10	Ethernet management port

The Cisco NCS420X-RSP module has the following front panel interfaces. For information on cable pinout, see [Pinouts](#).

- 1 USB Type-A Connector for USB-flash (Label = “MEM”)
- 1 USB Type-A Connector for alternate console port (Label = “CONSOLE”)
- RJ45 Connector for Con/Aux (Label = “CONSOLE”)
- RJ48 Jack for BITS interface. (Label = “BITS”)
- RJ48 Jack for Time-of-Day interface. (Label= “TOD”)
- RJ45 Connector for Con/Aux (Label = “MGMT ENET”)
- 4 Mini-Coax connectors (Label = “1PPS IN”, “1PPS OUT”, “10MHZ IN”, “10MHZ OUT”)

For more information about installing the RSP, see [RSP Installation](#). For more information about the RSP LEDs, see [RSP LEDs](#).

Power Supply Features

The Cisco NCS 4206 support DC power supplies. For more information about installing the Cisco NCS 4206 power supplies, see [Installing the Power Supply](#).

To estimate the required power supply, use the [Cisco Power Calculator](#).

The power sections provide more information about the power supply.

Interface Modules

The Cisco NCS 4206 Router interface modules are a field-replaceable unit. In addition to the ports provided on an RSP, the Cisco NCS 4206 Router supports the following interface modules:

8-port 10 Gigabit Ethernet Interface Module (8X10GE)

Figure 9: 8x10 Gigabit Ethernet Interface Module

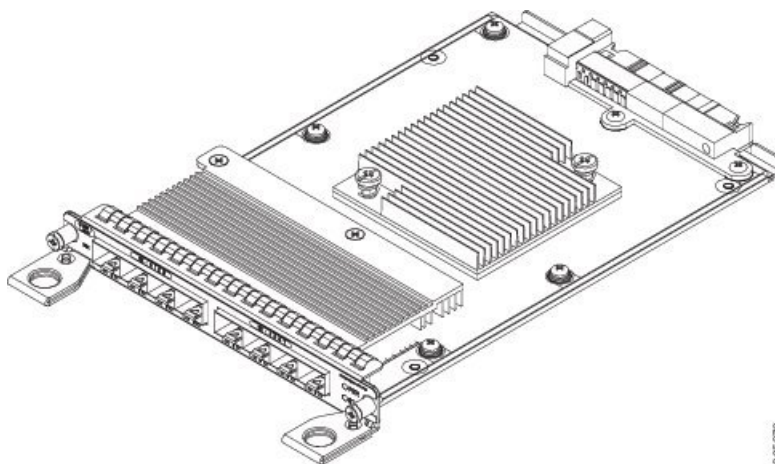
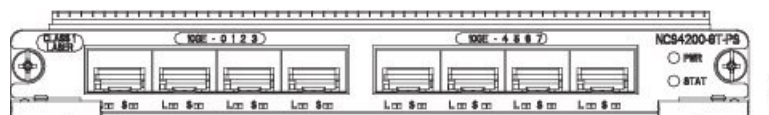

Figure 10: NCS4200-8T-PS Faceplate



The high density 8x10 Gigabit Ethernet interface module supports eight 10 Gigabit Ethernet ports using SFP+ transceivers cages on the faceplate.



Note 8x10 Gigabit Ethernet interface module does not support XFP transceivers on the ports.

For more information about installing a 8X10GE module, see [Interface Module Installation](#).

1-port 100 Gigabit Ethernet Interface Module (1X100GE)

The single port 100 Gigabit Ethernet interface module supports 100 Gigabit Ethernet port.

Figure 11: 1x100 Gigabit Ethernet Interface Module

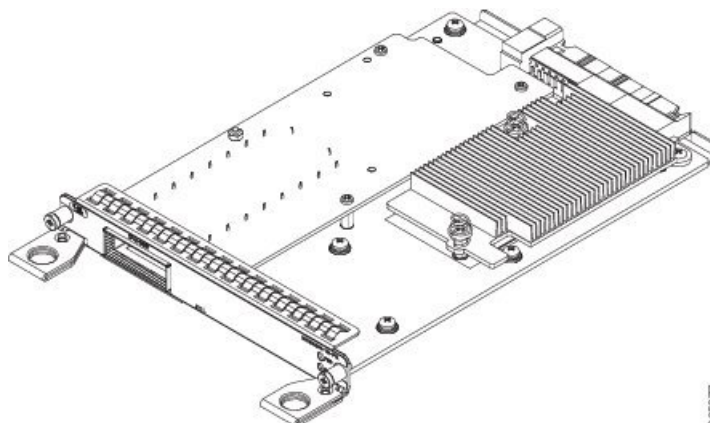
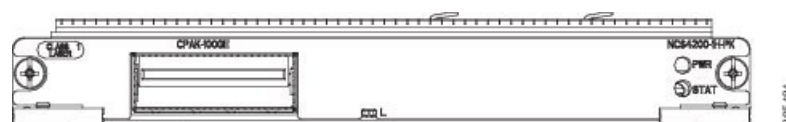

Figure 12: NCS4200-1H-PK Faceplate



For more information about installing a 1X100GE module, see [Interface Module Installation](#).

2-Port 100 Gigabit Ethernet Interface Module (2X100GE)

The 2-port 100 Gigabit Ethernet Interface Module (NCS4200-2H-PQ) design supports only one 100G QSFP28 optics on Port 0. Port 1 is disabled with RSP3. It currently supports only one mode of operation with 100Gbps of traffic with RSP3.

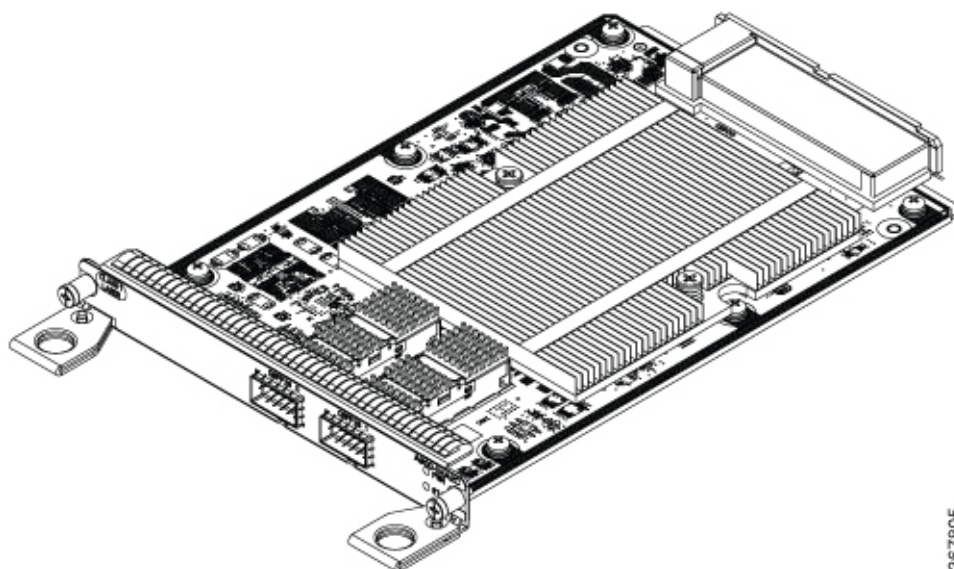

Limitations of 2X100 GE IM

After any QSFP28 100G optics is inserted, it takes approximately 10 seconds for the optics to be detected and the link to come up. We recommend this time delay for complete initialization and operation.

After inserting the cable or after unshutting the 100G interface, the 100G link may take approximately about 2 seconds to come up.



Note QSFP-100G-SR4-S and QSFP-100G-LR4-S are the supported optics for 2X100GE IM for the release 16.10.1.

8x1 Gigabit Ethernet SFP + 1x10 Gigabit Ethernet SFP+ Combination Interface Module

The 8-port 1 Gigabit Ethernet SFP interface module with the 1-port 10 Gigabit Ethernet interface module is a high density combination interface module. This module supports 8 Gigabit Ethernet SFP ports and 1 10 Gigabit Ethernet SFP+ port.

Figure 13: 2x40 Gigabit Ethernet Interface Module

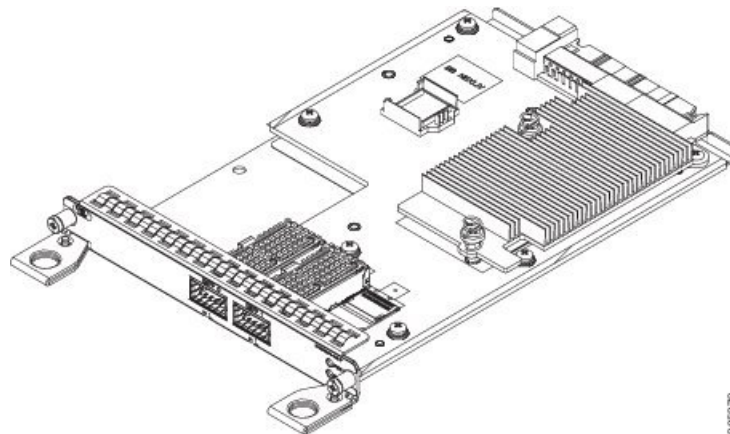
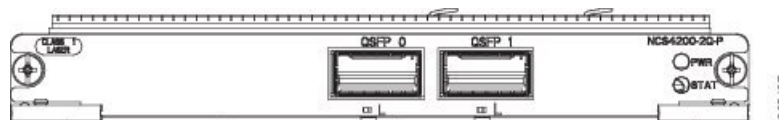

Figure 14: NCS4200-200-P Faceplate



For more information about installing the 8X1 GE SFP + 1X10 SFP Gigabit Ethernet module, see [Interface Module Installation](#).

2-port 40 Gigabit Ethernet QSFP Interface Module (2X40GE)

The dual port 40 Gigabit Ethernet interface module supports the 40 Gigabit Ethernet port. The 40G interface is supported using QSFP+ optics.

For more information about installing a 2X40 GE module, see [Installing an Interface Module](#).

1-port OC-192 or 8-port Low Rate CEM Interface Module (10G HO / 10G LO)

The OC-192 interface module with 8-port low rate CEM interface module is a high density combination interface module. This module supports 1-port OC-192 port or 8 low rate CEM or 1 Gigabit Ethernet port.

Figure 15: OC-192 Interface Module

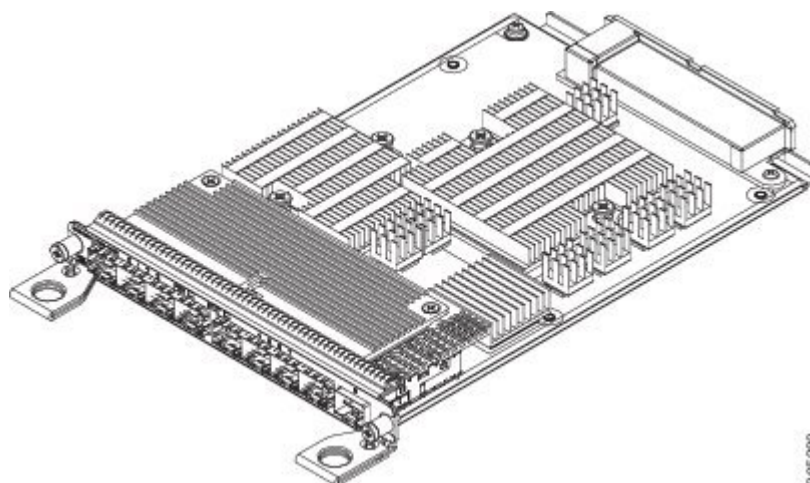
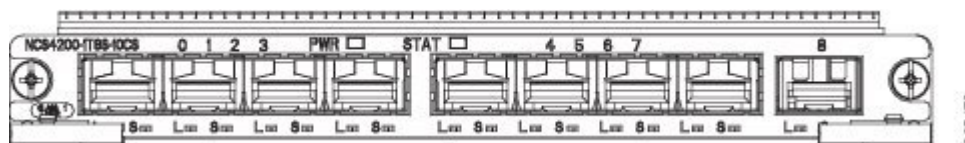

Figure 16: NCS4200-1T8S-10CS Faceplate



The OC-192 interface modules are supported on slots 2, 3, 4 and 5 on the chassis.

Ports on the OC-192 are numbered from 1 to 8.

- Ports 0 to 7 are multi-rate ports, that support OC-3, OC-12, OC-48, Fast Ethernet interfaces, and the 1 Gigabit Ethernet interfaces.
- Port 8 is the 10 Gigabit Ethernet port that supports the OC-192 interfaces.

Port Restrictions

- The SFP+ port configuration is supported only on OC-192 interfaces port. If this port is enabled, other SFP ports cannot be used (see the table below).
- Each SFP port can be configured for SONET or Ethernet.
- SFP ports configuration parameter, (see the table below):
 - Maximum of 4 x OC-48 interfaces are supported per interface module
 - For each OC-48 port enabled, neighboring SFP ports cannot be configured
 - OC-3 and OC-12 port configuration is supported on all ports simultaneously
 - 1 Gigabit Ethernet port configuration is supported on all ports simultaneously



Note 1 Gigabit Ethernet port configuration is not supported in Cisco IOS XE Release 3.18S.

- Seamless migration from SONET to 1 Gigabit Ethernet interfaces is supported on all SFP ports.

Port Combinations Usage Guidelines

SFP+ Port	SFP+ Port	OC-192	Or	SFP+ Port	SFP+ Port	—	Or	SFP+ Port	SFP+ Port	—	Or	SFP+ Port	SFP+ Port	—
	8				8				8				8	
SPF Port	7	—		SPF Port	7	OC-48		SPF Port	7	OC-3		SPF Port	7	1 GE
	6	—			6	—			6	OC-12			6	1 GE
	5	—			5	OC-48			5	OC-12			5	1 GE
	4	—			4	—			4	OC-3			4	1 GE
	3	—			3	OC-48			3	OC-3			3	1 GE
	2	—			2	—			2	OC-12			2	1 GE
	1	—			1	OC-48			1	OC-12			1	1 GE
	0	—			0	—			0	OC-3			0	1 GE

For more information about installing the OC-192 interface module, see [Interface Module Installation](#).

NCS 4200 1-Port OC-192 or 8-Port Low Rate CEM 20G Bandwidth Interface Module (NCS4200-1T8S-20CS)

The NCS 4200 1-Port OC-192 or 8-Port Low Rate CEM 20G Bandwidth Interface Module, iMSG is a cost-effective interface module (IM) that supports CEM and Multiservice Gateway features on the OCn interfaces.



Note The Multiservice Gateway features are not supported on this IM on Cisco IOS XE Release 16.12.1.

Figure 17: CEM and iMSG Interface Module

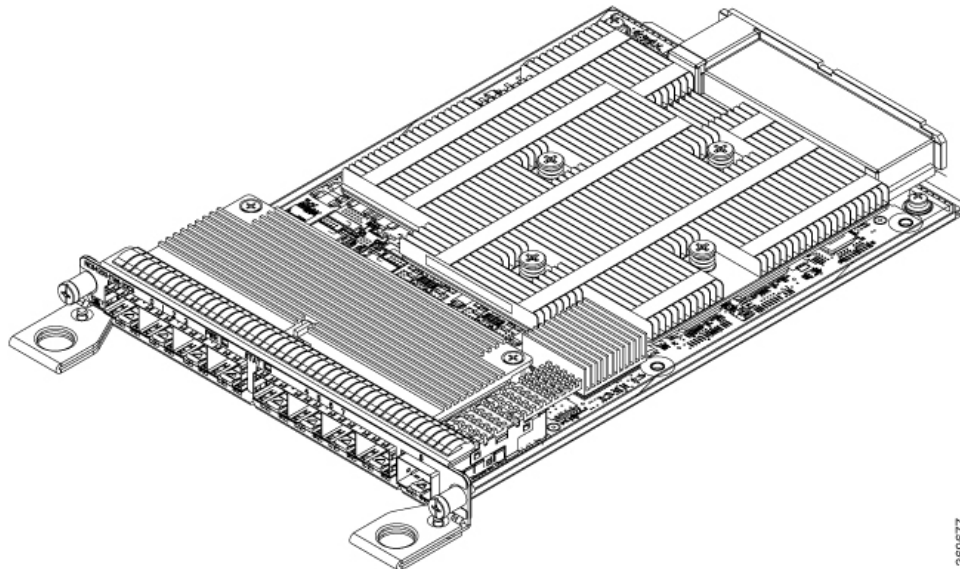

The NCS 4200 1-Port OC-192 or 8-Port Low Rate CEM 20G Bandwidth Interface Module, iMSG IM supports eight SFP optical interfaces supporting at OC-3/OC-12/OC-48/1G rates and a single SFP+ optical interface supporting at OC-192/10G.

This IM operates in two modes:

- 20G mode; uses two XFI lanes towards the system
- 10G mode; uses single XFI lane towards the system

The benefits of this IM are:

- Improves backplane efficiency
- Increases system capacity
- Increases client flexibility

The most important feature of the NCS 4200 1x10G MR + 8x20G LR CEM, iMSG IM is it provides more flexibility from the interface, which allows you to configure any interface speed on the OCn port irrespective of the IM bandwidth. The bandwidth restriction comes into effect only when the circuit is configured.

For example, you can configure the SFP+ port as an OC-192 and the other eight optical ports as OC-48 to have the total interface speed of 30G. However, if you configure only one STS-1 HO CEP on each port that will take only 9xSTS-1, which is equivalent to 500 Mbps (9 x 52Mbps x1.06) of the backplane traffic.

Restrictions

- On the port capable of OC-192 speed, lower speed such as, OC-3, OC-12, or OC-48 are not supported.
- No license is required to enable the Ethernet, OTN and Sonet/SDH functionalities.
- The SFP port supports OC-3, OC-12, and OC-48. SFP+ port supports OC-192.

Support Information

Table 4: Supported RSP and Slots

Router	RSP Module	Recommended Slots	Supported Mode
NCS 4206	A900-RSP3-400	2, 3, 4, 5	10G or 20G
NCS 4216 ⁵	A900-RSP3-400	3, 7, 11	10G or 20G Note To enable this IM on slot 0 or slot 1, do the following: Router# configure t Router(config)# license feature service-offload enable Reload the router.
		5, 9, 13, 15	10G
NCS 4216 F2B	A900-RSP3-400	0, 1, 2, 5, 6, 9, 10, 13, 14, 15	10G
	A900-RSP3-400	3, 4, 7, 8, 11, 12	20G

⁵ If this IM is inserted in any of the even-numbered slots, the corresponding odd-numbered slot must be unused and filled with a blank.

8/16-Port 1 Gigabit Ethernet (SFP / SFP) + 1-port 10 Gigabit Ethernet (SFP+) / 2-port 1 Gigabit Ethernet (CSFP) Interface Module

The NCS4200-1T16G-PS interface module has the flexibility to support SFP+/SFP/CSFP on the modules as mentioned below:

- The 8-port 1 Gigabit Ethernet ports can also be used as 16-port 1 Gigabit Ethernet ports Small Form-Factor Pluggable (SFP) .
- The 1-port 10 Gigabit Ethernet port can also be used as 2-port 1 Gigabit Ethernet ports with Small Form-Factor Pluggable (SFP+).

Figure 18: NCS4200-1T16G-PS Gigabit Ethernet Interface Module

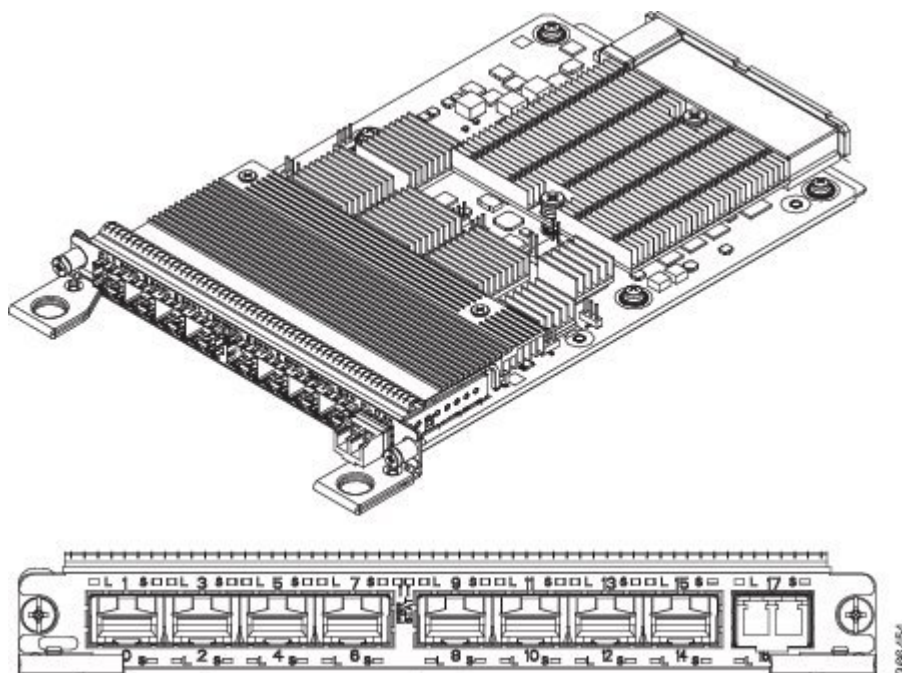

The following modes are supported for the Interface Module, based on slot capacity:

- 8 x 1GigE (SFP) Fully subscribed mode (FS)
- 8 x 1GigE (SFP) + 1 x 10GigE (SFP+) Fully subscribed mode (FS)
- 16 x 1GigE (C-SFP) + 1 x 10GigE (SFP+) Fully subscribed mode (FS)
- 16 or 18 x 1GigE (C-SFP) Oversubscribed mode (OS)
- 16 x 1GigE (C-SFP) + 1 x 10GigE (SFP+) Oversubscribed mode (OS)
- 8 or 9 x 1GigE (SFP) Fully subscribed mode (FS)
- 1 x 10GigE (SFP+) Fully subscribed mode (FS)

For more information about installing a 1xSFP or CSFP and 8xSFP or CSFP, see [Installing an Interface Module](#).

For more information on port numbering, see Configuring 8/16-port 1 Gigabit Ethernet (SFP/SFP) + 1-port 10 Gigabit Ethernet (SFP+) / 2-port 1 Gigabit Ethernet (CSFP) Interface Module chapter of the [Cisco NCS 4200 Series Software Configuration Guide, Cisco IOS XE Fuji 16.7.x](#).

1-Port OC48/ STM-16 or 4-port OC-12/OC-3 / STM-1/STM-4 + 12-port T1/E1 + 4-Port T3/E3 CEM Interface Module

The NCS4200-3GMS interface module supports:

- 12xDS1/E1 + 4xDS3/E3/STS-1e interface over the high-density port.
- 1xOC48/12/3 or 1GE interface and 3xOC12/3 or 1GE interface.



Note If OC48 is enabled, then the remaining 3 ports are disabled.

Figure 19: NCS4200-3GMS Gigabit Ethernet Interface Module

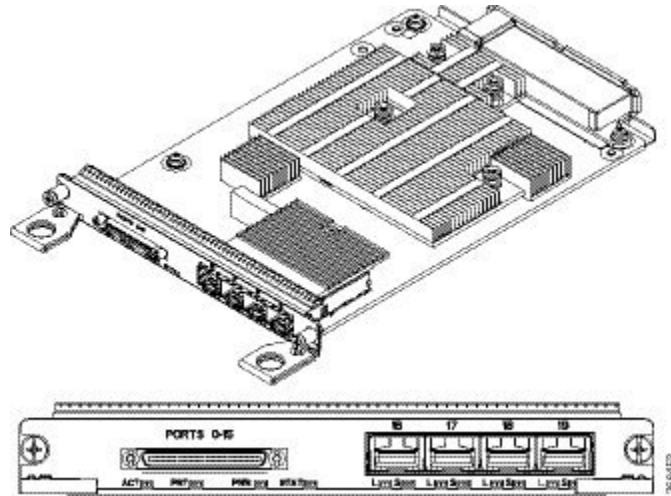

For more information on the supported SFP modules, see the [Cisco NCS 4200 Series Network Convergence System Interface Modules Data Sheet](#).

48-port T1/E1 CEM Interface Module

The 48-port T1/E1 interface module provides connectivity for up to 48-port T1/E1 ports through 3 high-density connectors on the front panel (see the figure below). Each port supports 16 TX and RX ports. For information on LEDs, see [Troubleshooting](#).

Figure 20: 48-port T1/E1 Interface Module

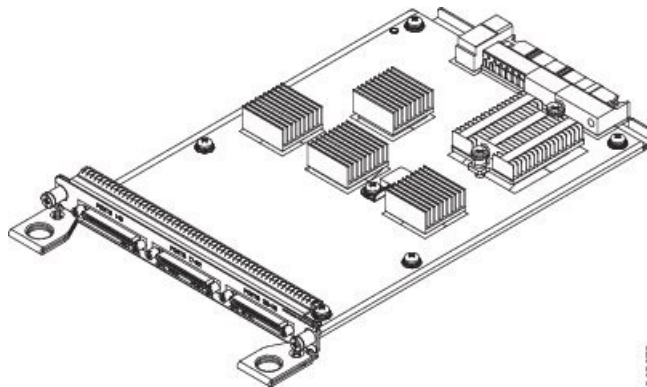
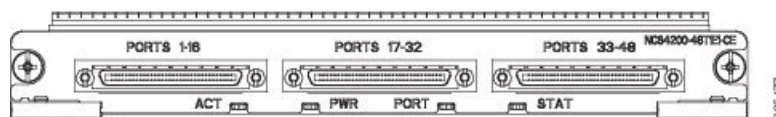

Figure 21: NCS4200-48T1E1-CE Faceplate



For more information about installing the 48-port T1/E1 interface module, see [Interface Module Installation](#).

48-port T3/E3 CEM Interface Module

The 48-port T3/E3 interface module provides connectivity for up to 48-port T3/E3 ports through 3 high-density connectors on the front panel (see the figure below). Each port supports 16 TX and RX ports. For information on LEDs, see [Troubleshooting](#).

Figure 22: 48-port T3/E3 Interface Module

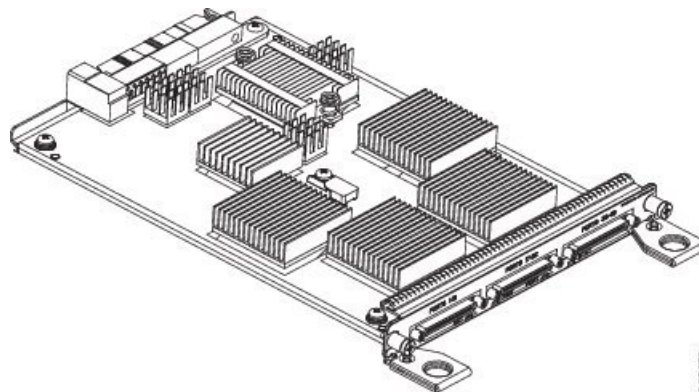
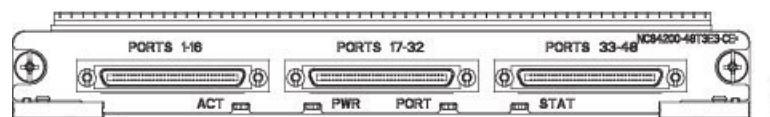

Figure 23: NCS4200-T3E3-CE Faceplate



For more information about installing the 48-port T3/E3 interface module, see [Interface Module Installation](#).

8-port T1/E1 Interface Module (A900-IMA8D)

The 8-port T1/E1 interface module provides connectivity for up to 8 T1/E1 ports through RJ48C port connectors on the front panel. The figure below shows the interface module. For information on supported slots, see *Supported RSPs*.

Figure 24: 8-port T1/E1 Interface Module

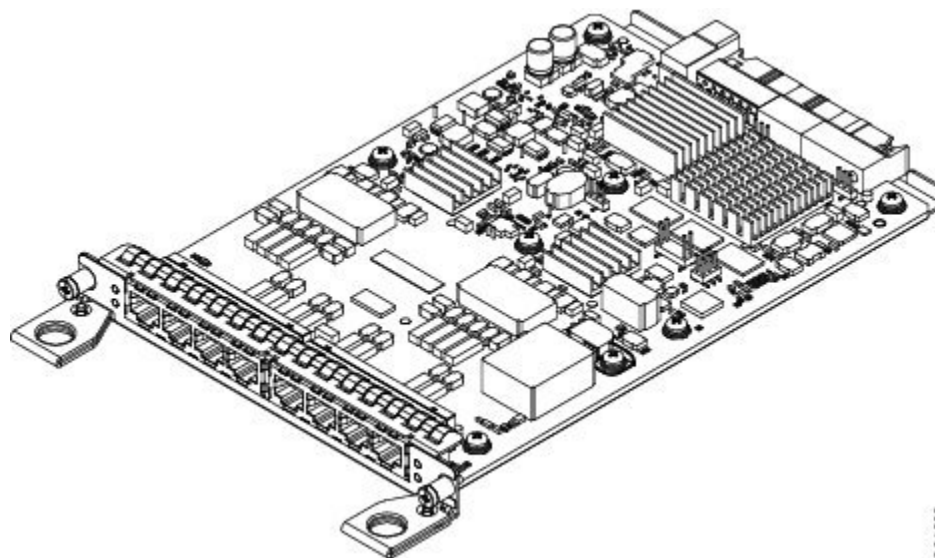

364-202

Temperature Sensor

The Cisco NCS 4206 has a temperature sensor to detect overtemperature conditions inside the chassis.

Temperature Sensors on the RSP modules

The maximum operating temperature of NCS420X-RSP module and the interface modules is less than the maximum operating temperature of the Cisco NCS 4206.

The IOS XE software decides the appropriate temperature thresholds to generate warnings, and shuts down the system when abnormally high temperature is detected.

Patch Panels

The Cisco router has patch panels modules that provide interconnections with the interface modules.

The following table shows different types of patch panel:

Table 5: T1/E1 Patch Panel

Patch Panel	Description
PANEL-48-1-DIN	48X75 ohm E1/DS1 termination, through DIN 1.0/2.3 connectors
PANEL-48-1-RJ48	48X120 ohm E1/110 ohm DS1 termination, through RJ 48C connector
PANEL-48-1-AMP64	48X120 ohm E1/110 ohm DS1 termination, through 4xAMP 64-pin
PANEL-144-1-AMP64	144X120 ohm E1/110 ohm DS1 termination, through 12XAMP64-pin

Table 6: T3/E3 Patch Panel

Patch Panel	Description
PANEL-48-3-DIN	48X75 ohm E3/DS3 termination, through DIN 1.0/2.3 connectors
PANEL-48-3-HDBNC	48X75 ohm E3/DS3 termination, through HDBNC connectors

The 48 X T1/E1 TDM interface modules and 48 X T3/E3 TDM interface modules supports a maximum of 48 TDM ports. These ports are available on the interface modules through three Very-High-Density Cable Interconnect (VHDCI) 16-port connectors. The patch panels listed above make these 48 ports available to the user via different port densities (48- or 144-port patch panels) with standard Telco connectors (DIN, RJ48, and AMP64 for T1/E1 and DIN, HDBNC for T3/E3).

Figure 25: VHDCI 16-port Connectors Interface View

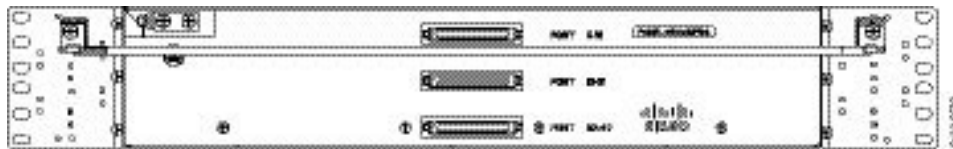

Figure 26: PANEL-48-1-RJ48 Interface View

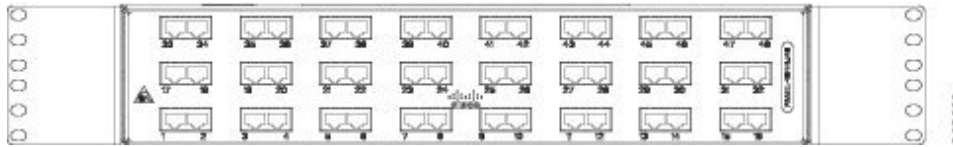

Figure 27: PANEL-48-1-AMP64 Interface View



Figure 28: PANEL-48-1-DIN or PANEL-48-3-DIN Interface View

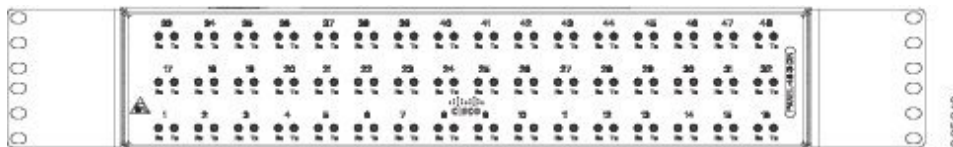

Figure 29: PANEL-144-1-AMP64 Interface View

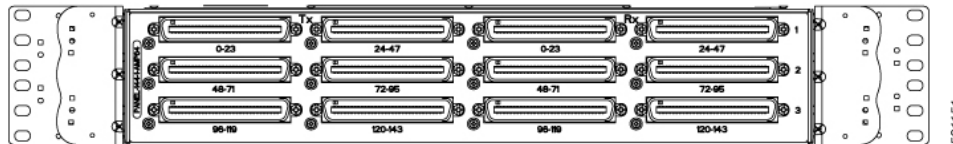

Figure 30: PANEL-48-3-HDBNC InterfaceView

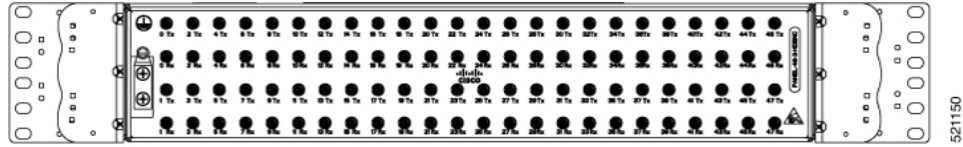

Figure 31: Patch Panel System Interface View

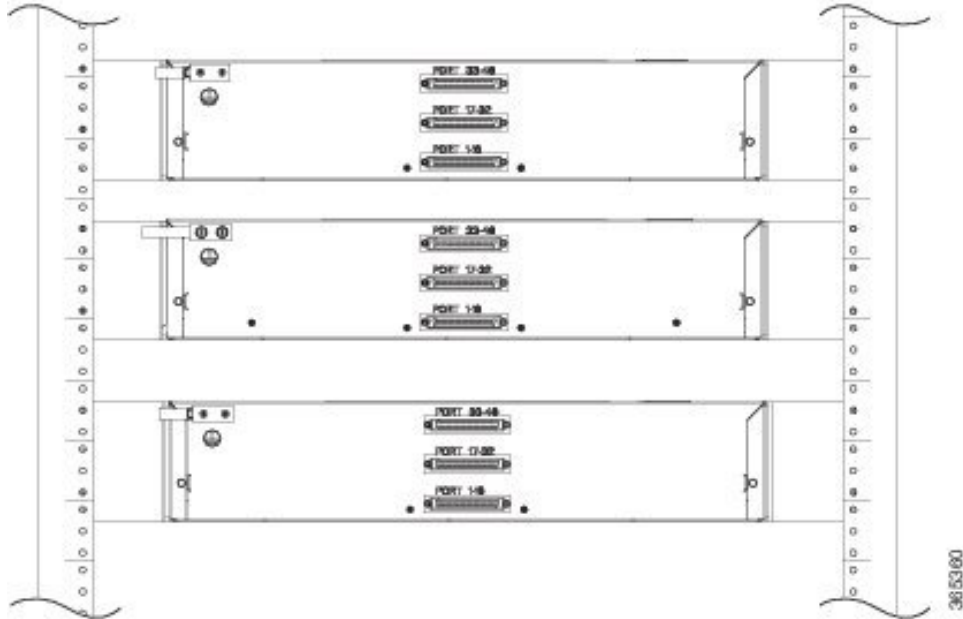
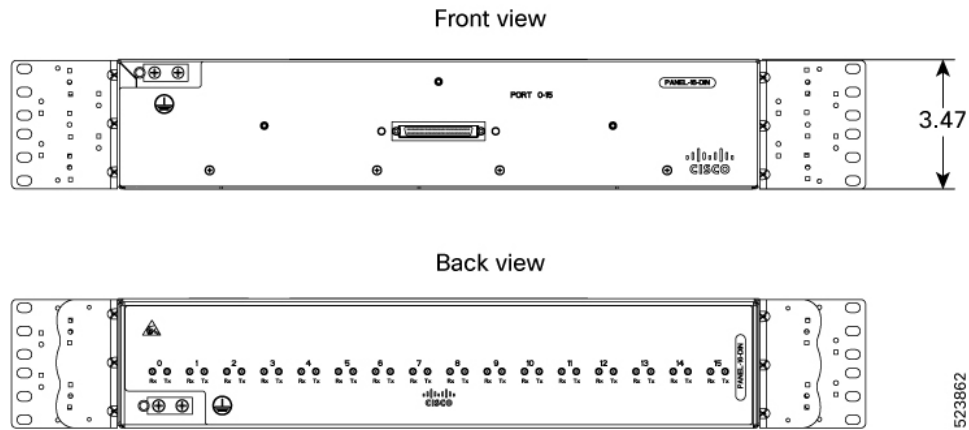

Table 7: PANEL-16-DIN

Patch Panel	Description
PANEL-16-DIN	16X75 ohm E1 termination, through DIN 1.0/2.3 connectors

The 48 X T1/E1 TDM interface modules and the 48 X T3/E3 TDM interface modules support a maximum of 48 TDM ports. These ports are available on the interface modules through three Very-High-Density Cable Interconnect (VHDCI) 16-port connectors. The patch panels listed above make these 48 ports available to the user via different port densities (48- or 144-port patch panels) with standard Telco connectors (DIN, RJ48, and AMP64 for T1/E1 and DIN, HDBNC for T3/E3).

Figure 32: PANEL-16-DIN Interface View



Interface Numbering

The Cisco NCS 4206 chassis includes:

- Six interface module slots
- Two RSP module slots
- Two power supply slots
- One fan tray slot

Each network interface on a Cisco NCS 4206 is identified by a slot number and a port number.

The figure below shows interface numbering in a Cisco NCS 4206.

Figure 33: Cisco NCS 4206 Slot Numbers

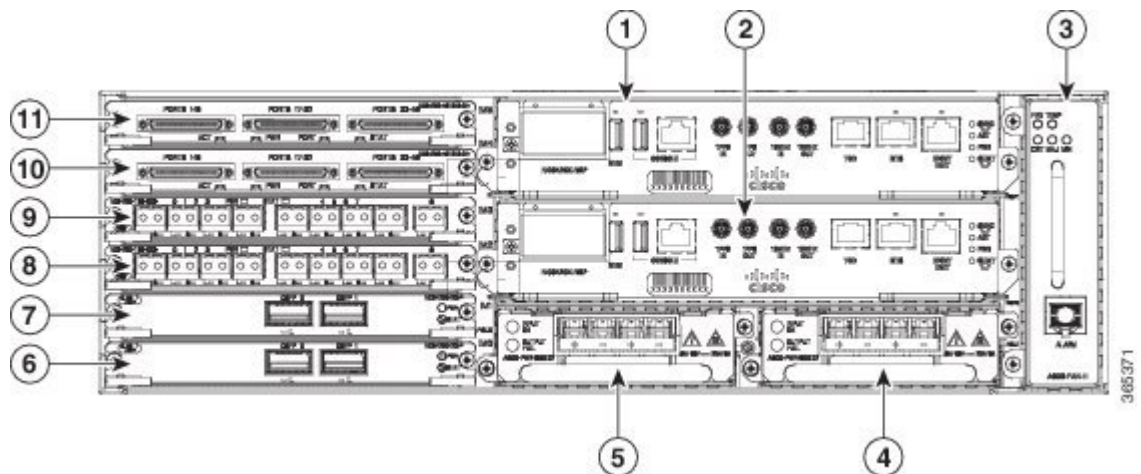

1	RSP slot 1
2	RSP slot 0
3	Fan tray slot

4	Power supply slot 1
5	Power supply slot 0
6	Interface module slot 0
7	Interface module slot 1
8	Interface module slot 2
9	Interface module slot 3
10	Interface module slot 4
11	Interface module slot 5

Following is an explanation of the slot or port numbering:

- The numbering format is **Interface type slot or interface number**. Interface (port) numbers begin at logical 0 for each interface type.
- Interface module slots are numbered from bottom to top, with logical interfaces on each module numbered from left to right. Interfaces are hard-wired. Therefore, port 0 is always logical interface 0/0, port 1 is always logical interface 0/1, and so on.

The input parameter for the following commands changes based on the active RSP slot number. The active RSP in slot 0 is referred to as “0/ slot_num”, else if the active RSP is slot 1, it is referred to as 1/“slot_num”. The output for the command is displayed accordingly:

- **show diag all eeprom detail**
- **show platform software trace message iomd**
- **show platform software agent iomd**
- **show platform software peer shell-manager brief**
- **show platform software peer chassis-manager**
- **show platform software memory iomd**
- **set platform software trace iomd**

Regulatory Compliance

For regulatory compliance and safety information, see the *Regulatory Compliance and Safety Information for the Cisco NCS 4206* document.



CHAPTER 2

Preparing for Installation

This chapter describes how to prepare for the installation of the Cisco NCS 4206 at your site.

- [Safety Guidelines, on page 27](#)
- [Site Planning, on page 37](#)
- [Receiving the Cisco NCS 4206, on page 46](#)

Safety Guidelines

Before you begin the installation of the Cisco NCS 4206, review the safety guidelines in this chapter to avoid injuring yourself or damaging the equipment.

In addition, before replacing, configuring, or maintaining the Cisco NCS 4206, review the safety warnings listed in Regulatory Compliance and Safety Information for the Cisco NCS 4206.

Standard Warning Statements

To see translations of the warnings that appear in this publication, refer to the Regulatory Compliance and Safety Information document that accompanied this device.



Warning The appliance must be connected to a grounded outlet. Statement 0414



Warning To avoid or reduce the risk of personal injury, do not use the product if the product has been exposed to irregular environmental conditions, if the product has been misused or if parts of the product have been damaged. Consult qualified service personnel. Never try to service the product yourself. Statement 0416



Warning To reduce the risk of electric shock, fire or personal injury, do not place power cables in areas where they may be walked on or damaged by items placed upon or against it. Statement 0417



Warning This product is intended for use in a normal environment based on the standard IEC 60950-1. Do not use the product in vehicles, on board ships, in aircrafts or in medical applications with physical connection to the patient, nor in environments with exposure to moisture, dust, vibration or ingress of water. Statement 0418



Warning Do not work on the system or connect or disconnect cables during periods of lightning activity. Statement 1001



Warning Read the installation instructions before connecting the system to the power source. Statement 1004



Warning To prevent bodily injury when mounting or servicing this unit in a rack, you must take special precautions to ensure that the system remains stable. The following guidelines are provided to ensure your safety: This unit should be mounted at the bottom of the rack if it is the only unit in the rack. When mounting this unit in a partially filled rack, load the rack from the bottom to the top with the heaviest component at the bottom of the rack. If the rack is provided with stabilizing devices, install the stabilizers before mounting or servicing the unit in the rack. Statement 1006



Warning This unit is intended for installation in restricted access areas. A restricted access area can be accessed only through the use of a special tool, lock and key, or other means of security. Statement 1017



Warning To reduce the risk of fire, use only No. 26 AWG or larger telecommunication line cord. Statement 1023



Warning If the symbol of suitability with an overlaid cross appears above a port, you must not connect the port to a public network that follows the European Union standards. Connecting the port to this type of public network can cause severe injury or damage your . Statement 1031



Warning Do not use this product near water; for example, near a bath tub, wash bowl, kitchen sink or laundry tub, in a wet basement, or near a swimming pool. Statement 1035



Warning Never install telephone jacks in wet locations unless the jack is specifically designed for wet locations. Statement 1036



Warning Never touch uninsulated telephone wires or terminals unless the telephone line has been disconnected at the network interface. Statement 1037



Warning Avoid using a telephone (other than a cordless type) during an electrical storm. There may be a remote risk of electric shock from lightning. Statement 1038



Warning To report a gas leak, do not use a telephone in the vicinity of the leak. Statement 1039



Warning Ultimate disposal of this product should be handled according to all national laws and regulations. Statement 1040



Warning Before opening the unit, disconnect the telephone-network cables to avoid contact with telephone-network voltages. Statement 1041



Warning To prevent the system from overheating, do not operate it in an area that exceeds the maximum recommended ambient temperature of 149°F (65°C). Statement 1047



Warning The chassis should be mounted on a rack that is permanently affixed to the building. Statement 1049



Warning IMPORTANT SAFETY INSTRUCTIONS: This warning symbol means danger. You are in a situation that could cause bodily injury. Before you work on any equipment, be aware of the hazards involved with electrical circuitry and be familiar with standard practices for preventing accidents. Use the statement number provided at the end of each warning to locate its translation in the translated safety warnings that accompanied this device. Statement 1071



Warning No user-serviceable parts inside. Do not open. Statement 1073



Warning This is a Class A Device and is registered for EMC requirements for industrial use. The seller or buyer should be aware of this. If this type was sold or purchased by mistake, it should be replaced with a residential-use type. Statement 294

**Warning**

This is a class A product. In a domestic environment this product may cause radio interference in which case the user may be required to take adequate measures. Statement 340

**Warning**

This equipment is in compliance with the essential requirements and other relevant provisions of Directive 1999/5/EC.

Safety Guidelines for Personal Safety and Equipment Protection

The following guidelines help ensure your safety and protect the equipment. This list does not include all the potentially hazardous situations. Therefore, you should be on alert.

- Before moving the system, always disconnect all the power cords and interface cables.
- Never assume that power is disconnected from a circuit; always check.
- Before and after installation, keep the chassis area clear and dust-free.
- Keep tools and assembly components away from walk areas where you or others could trip over them.
- Do not work alone if potentially hazardous conditions exist.
- Do not perform any action that creates a potential hazard to people or makes the equipment unsafe.
- Do not wear loose clothing that may get caught in the chassis.
- When working under conditions that may be hazardous to your eyes, wear safety glasses.

Safety Precautions for Module Installation and Removal

Be sure to observe the following safety precautions when you work on the .

To see translations of the warnings that appear in this publication, refer to the Regulatory Compliance and Safety Information document that accompanied this device.

**Warning**

For connections outside the building where the equipment is installed, the following ports must be connected through an approved network termination unit with integral circuit protection . Statement 1044

**Warning**

Invisible laser radiation may be emitted from disconnected fibers or connectors. Do not stare into beams or view directly with optical instruments. Statement 1051

**Warning**

Class 1M laser radiation when open. Do not view directly with optical instruments. Statement 1053

**Warning**

Class 1 CDRH) and Class 1M (IEC) laser products. Statement 1055



Warning Invisible laser radiation may be emitted from the end of the unterminated fiber cable or connector. Do not view directly with optical instruments. Viewing the laser output with certain optical instruments (for example, eye loupes, magnifiers, and microscopes) within a distance of 100 mm may pose an eye hazard. Statement 1056



Warning Do not stare into the beam or view it directly with optical instruments. Statement 1011



Warning Invisible laser radiation present. Statement 1016



Warning Hazardous network voltages are present in WAN ports regardless of whether power to the unit is OFF or ON. To avoid electric shock, use caution when working near WAN ports. When detaching cables, detach the end away from the unit first. Statement 1026



Warning Blank faceplates and cover panels serve three important functions: they prevent exposure to hazardous voltages and currents inside the chassis; they contain electromagnetic interference (EMI) that might disrupt other equipment; and they direct the flow of cooling air through the chassis. Do not operate the system unless all cards, faceplates, front covers, and rear covers are in place. Statement 1029



Warning Hazardous voltage or energy is present on the backplane when the system is operating. Use caution when servicing. Statement 1034



Warning Invisible laser radiation may be emitted from disconnected fibers or connectors. Do not stare into beams or view directly with optical instruments. Statement 1051

Safety with Electricity



Warning Before working on a chassis or working near power supplies, unplug the power cord on AC units; disconnect the power at the circuit breaker on DC units. Statement 12



Warning Before working on equipment that is connected to power lines, remove jewelry (including rings, necklaces, and watches). Metal objects will heat up when connected to power and ground and can cause serious burns or weld the metal object to the terminals. Statement 43

**Warning**

To prevent accidental discharge in the event of a power line cross, route on-premise wiring away from power cables and off-premise wiring, or use a grounded shield to separate the on-premise wiring from the power cables and off-premise wiring. A power line cross is an event, such as a lightning strike, that causes a power surge. Off-premise wiring is designed to withstand power line crosses. On-premise wiring is protected from power line crosses by a device that provides overcurrent and overvoltage protection. Nevertheless, if the on-premise wiring is in close proximity to or not shielded from, the off-premise wiring or power cable during a lightning strike or power surge, the on-premise wiring can carry a dangerous discharge to the attached interface, equipment, or nearby personnel. Statement 338

**Warning**

High leakage current – earth connection essential before connection to system power supply. Statement 342

**Warning**

Do not work on the system or connect or disconnect cables during periods of lightning activity. Statement 1001

**Warning**

Before performing any of the following procedures, ensure that power is removed from the DC circuit. Statement 1003

**Warning**

Read the installation instructions before connecting the system to the power source. Statement 1004

**Warning**

This product relies on the building's installation for short-circuit (overcurrent) protection. Ensure that the protective device is rated for 900W DC Power Supply (PID A900-PWR900-D2): For a –48/–60 VDC installation, the wire shall be 8 AWG minimum with a 30 A circuit breaker. Statement 1005

**Warning**

This product relies on the building's installation for short-circuit (overcurrent) protection. For an AC installation, ensure that the branch circuit breaker is rated a maximum 20A.

**Warning**

There is the danger of explosion if the battery is replaced incorrectly. Replace the battery only with the same or equivalent type recommended by the manufacturer. Dispose of used batteries according to the manufacturer's instructions. Statement 1015

**Warning**

This unit is intended for installation in restricted access areas. A restricted access area can be accessed only through the use of a special tool, lock and key, or other means of security. Statement 1017



Warning Take care when connecting units to the supply circuit so that wiring is not overloaded. Statement 1018



Warning The plug-socket combination must be accessible at all times, because it serves as the main disconnecting device. Statement 1019



Warning To avoid electric shock, do not connect safety extra-low voltage (SELV) circuits to telephone-network voltage (TNV) circuits. LAN ports contain SELV circuits, and WAN ports contain TNV circuits. Some LAN and WAN ports both use RJ45 connectors. Use caution when connecting cables. Statement 1021



Warning A readily accessible two-poled disconnect device must be incorporated in the fixed wiring. Statement 1022



Warning To reduce the risk of fire, use only 26 AWG or larger telecommunication line cord. Statement 1023



Warning This equipment must be grounded. Never defeat the ground conductor or operate the equipment in the absence of a suitably installed ground conductor. Contact the appropriate electrical inspection authority or an electrician if you are uncertain that suitable grounding is available. Statement 1024



Warning Use copper conductors only. Statement 1025



Warning Hazardous network voltages are present in WAN ports regardless of whether power to the unit is OFF or ON. To avoid electric shock, use caution when working near WAN ports. When detaching cables, detach the end away from the unit first. Statement 1026



Warning This unit might have more than one power supply connection. All connections must be removed to de-energize the unit. Statement 1028



Warning To prevent personal injury or damage to the chassis, never attempt to lift or tilt the chassis using the handles on modules (such as power supplies, fans, or cards); these types of handles are not designed to support the weight of the unit. Statement 1032



Warning Connect the unit only to DC power source that complies with the safety extra-low voltage (SELV) requirements in IEC 60950 based safety standards. Statement 1033



Warning Do not use this product near water; for example, near a bath tub, wash bowl, kitchen sink or laundry tub, in a wet basement, or near a swimming pool. Statement 1035



Warning Never install telephone jacks in wet locations unless the jack is specifically designed for wet locations. Statement 1036



Warning Before opening the unit, disconnect the telephone-network cables to avoid contact with telephone-network voltages. Statement 1041



Warning This equipment must be installed and maintained by service personnel as defined by AS/NZS 3260. Incorrectly connecting this equipment to a general-purpose outlet could be hazardous. The telecommunications lines must be disconnected 1) before unplugging the main power connector or 2) while the housing is open, or both. Statement 1043



Warning This product requires short-circuit (overturned) protection, to be provided as part of the building installation. Install only in accordance with national and local wiring regulations. Statement 1045



Warning When installing or replacing the unit, the ground connection must always be made first and disconnected last. Statement 1046



Warning When you connect or disconnect the power and relay connector with power applied, an electrical arc can occur. This could cause an explosion in hazardous area installations. Be sure that power is removed from the switch and alarm circuit. Be sure that power cannot be accidentally turned on or verify that the area is nonhazardous before proceeding. Failure to securely tighten the power and relay connector captive screws can result in an electrical arc if the connector is accidentally removed. Statement 1058



Warning Failure to securely tighten the power and relay connector captive screws can result in an electrical arc if the connector is accidentally removed. Statement 397



Warning This equipment is intended to be grounded. Ensure that the host is connected to earth ground during normal use.



Warning If you connect or disconnect the console cable with power applied to the switch or any device on the network, an electrical arc can occur. This could cause an explosion in hazardous location installations. Be sure that power is removed or the area is nonhazardous before proceeding. To verify switch operation, perform POST on the switch in a nonhazardous location before installation. Statement 1065



Warning Installation of the equipment must comply with local and national electrical codes. Statement 1074



Warning Hazardous voltage or energy may be present on DC power terminals. Always replace cover when terminals are not in service. Be sure uninsulated conductors are not accessible when cover is in place. Statement 1075

When working on equipment powered by electricity, follow these guidelines:

- Locate the room's emergency power-off switch. If an electrical accident occurs, you will be able to quickly turn off the power.
- Before working on the system, turn off the DC main circuit breaker and disconnect the power terminal block cable.
- Before doing the following, disconnect all power:
 - Working on or near power supplies
 - Installing or removing a chassis or network processor module
 - Performing most hardware upgrades
- Never install equipment that appears damaged.
- Carefully examine your work area for possible hazards, such as moist floors, ungrounded power extension cables, and missing safety grounds.
- Never assume that power is disconnected from a circuit; always check.
- Never perform any action that creates a potential hazard to people or makes the equipment unsafe.
- If an electrical accident occurs, proceed as follows:
 - Use caution, and do not become a victim yourself.
 - Turn off power to the .
 - If possible, send another person to get medical aid. Otherwise, determine the condition of the victim, and then call for help.
 - Determine whether the person needs rescue breathing or external cardiac compressions; then take appropriate action.

In addition, use the following guidelines when working with any equipment that is disconnected from a power source, but still connected to telephone wiring or network cabling:

- Never install telephone wiring during a lightning storm.
- Never install telephone jacks in wet locations unless the jack is specifically designed for it.

- Never touch uninsulated telephone wires or terminals unless the telephone line is disconnected at the network interface.
- When installing or modifying telephone lines, use caution.

Power Supply Considerations

Check the power at your site to ensure that you are receiving clean power (free of spikes and noise). Install a power conditioner if necessary.



Warning This equipment is designed for connection to TN and IT power systems. Statement 16

Preventing ESD Damage



Warning This equipment needs to be grounded. Use a green and yellow 6 AWG ground wire to connect the host to earth ground during normal use. Statement 383

Electrostatic discharge (ESD) can damage equipment and impair electrical circuitry. ESD can occur when electronic printed circuit cards are improperly handled and can cause complete or intermittent failures. When removing and replacing modules, always follow ESD prevention procedures:

- Ensure that the chassis is electrically connected to earth ground.
- Wear an ESD-preventive wrist strap, ensuring that it makes good skin contact. To channel unwanted ESD voltages safely to ground, connect the clip to an unpainted surface of the chassis frame. To guard against ESD damage and shocks, the wrist strap and cord must operate effectively.
- If no wrist strap is available, ground yourself by touching a metal part of the chassis.
- When installing a component, use any available ejector levers or captive installation screws to properly seat the bus connectors in the backplane or midplane. These devices prevent accidental removal, provide proper grounding for the system, and help to ensure that bus connectors are properly seated.
- When removing a component, use available ejector levers or captive installation screws, if any, to release the bus connectors from the backplane or midplane.
- Handle components by their handles or edges only; do not touch the printed circuit boards or connectors.
- Place a removed component board side up on an antistatic surface or in a static-shielding container. If you plan to return the component to the factory, immediately place it in a static-shielding container.
- Avoid contact between the printed circuit boards and clothing. The wrist strap only protects components from ESD voltages on the body; ESD voltages on clothing can still cause damage.
- Never attempt to remove the printed circuit board from the metal carrier.



Note For the safety of your equipment, periodically check the resistance value of the antistatic wrist strap. It should be between 1 and 10 Mohm.

Site Planning

The following sections describe how to plan for the installation of the Cisco NCS 4206.

General Precautions

Observe the following general precautions when using and working with your Cisco NCS 4206 system:

- Keep your system components away from radiators and heat sources and do not block cooling vents.
- Do not spill food or liquids on your system components and never operate the product in a wet environment.
- Do not push any objects into the openings of your system components. Doing so can cause fire or electric shock by shorting out interior components.
- Position system cables and power supply cables carefully. Route system cables and the power supply cable and plug so that they cannot be stepped on or tripped over. Be sure that nothing else rests on your system component cables or power cable.
- Do not modify power cables or plugs. Consult a licensed electrician or your power company for site modifications. Always follow your local and national wiring rules.
- If you turn off your system, wait at least 30 seconds before turning it on again to avoid system component damage.

Site Planning Checklist

Use the following checklist to perform and account for all the site planning tasks described in this chapter:

- The site meets the environmental requirements.
- The site's air conditioning system can compensate for the heat dissipation of the Cisco NCS 4206.
- The floor space that the Cisco NCS 4206 occupies can support the weight of the system.
- Electrical service to the site complies with the requirements.
- The electrical circuit servicing the Cisco NCS 4206 complies with the requirements.
- Consideration has been given to the console port wiring and limitations of the cabling involved, according to TIA/EIA-232F.
- The Cisco NCS 4206 Ethernet cabling distances are within limitations.
- The equipment rack in which you plan to install the Cisco NCS 4206 complies with requirements.
- In selecting the location of the rack, careful consideration has been given to safety, ease of maintenance, and proper airflow.

Site Selection Guidelines

The Cisco NCS 4206 requires specific environmental operating conditions. Temperature, humidity, altitude, and vibration can affect the performance and reliability of the . The following sections provide specific information to help you plan for the proper operating environment.

The Cisco NCS 4206 is designed to meet the industry EMC, safety, and environmental standards described in the Regulatory, Safety, and Compliance Information for the Cisco NCS 4206.

Environmental Requirements

The Cisco NCS 4206 is Telcordia GR-3108-CORE Class-1 or GR-63-Core Indoor compliant.

Environmental monitoring in the Cisco NCS 4206 protects the system and components from damage caused by excessive voltage and temperature conditions. To ensure normal operation and avoid unnecessary maintenance, plan and prepare your site configuration *before* installation. After installation, make sure that the site maintains the environmental characteristics described in [Cisco Network Convergence System 4200 Series Data Sheet](#).

For an outside plant installation (cell site cabinet, hut etc.), it is required that the chassis be protected against airborne contaminants, dust, moisture, insects, pests, corrosive gases, polluted air or other reactive elements present in the outside air. To achieve this level of protection, we recommend that the unit be installed in a fully sealed enclosure or cabinet. Examples of such cabinets include IP65 cabinets with heat exchanger complying with Telcordia GR487. Temperature must be maintained within -40°C to 65°C .

Physical Characteristics

Be familiar with the physical characteristics of the Cisco NCS 4206 to assist you in placing the system in the proper location.

Air Flow Guidelines

Cool air is circulated through the Cisco NCS 4206 by a fan tray located along the right side of the chassis. Air flow is side-to-side, right to left, as shown in the figure below.

Figure 34: Cisco NCS 4206 Chassis Air Flow

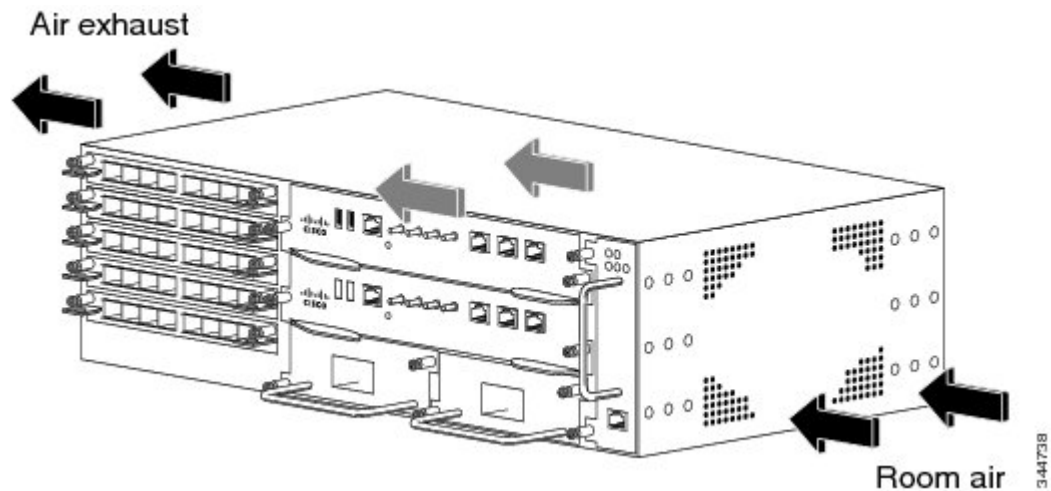

To ensure adequate airflow, it is recommended that you maintain a minimum clearance distance always, as mentioned in the following figure.

Figure 35: Front View of Cisco A903-F2B-AIR Clearance

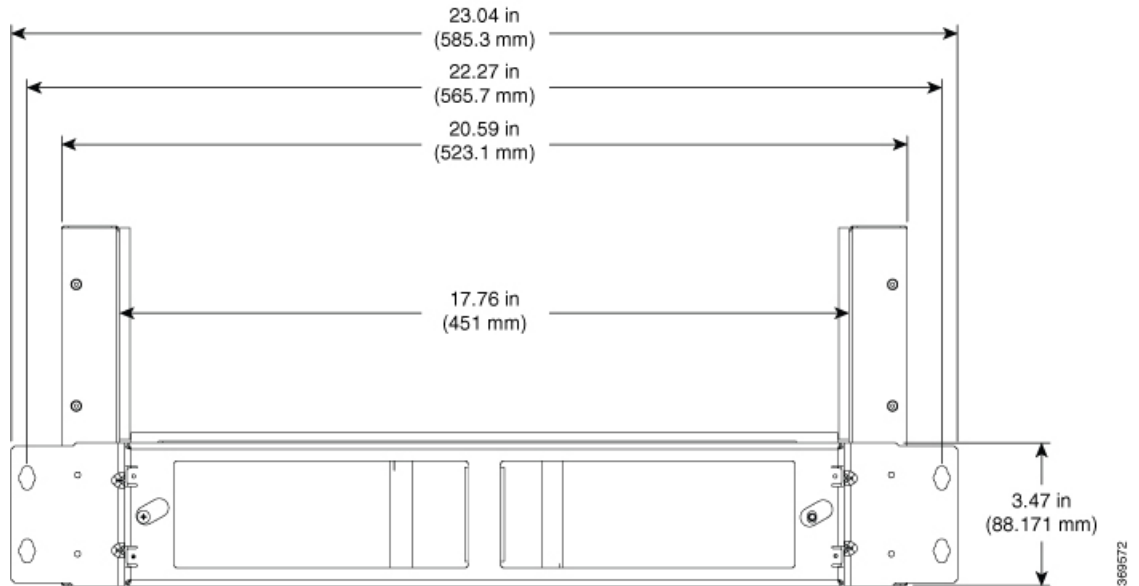
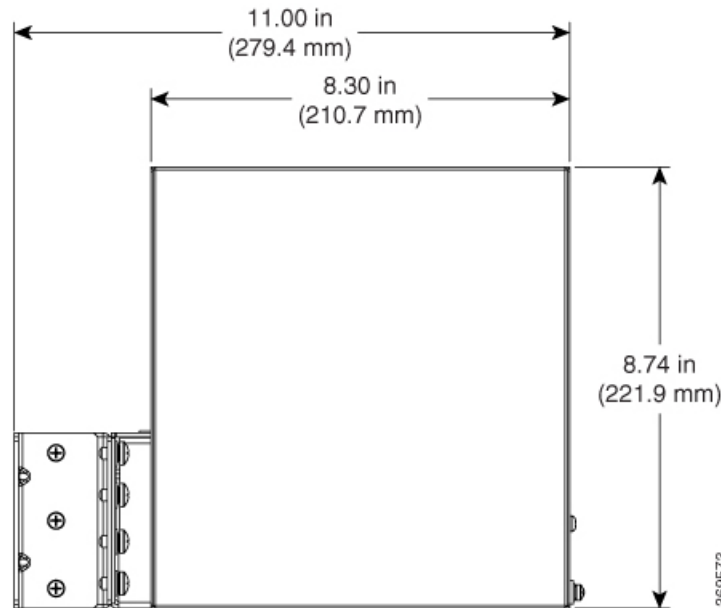

Figure 36: Side View of Cisco A903-F2B-AIR Clearance



The fan trays maintain acceptable operating temperatures for the internal components by drawing in cool air through the vents, and circulating the air through the chassis.

The following guidelines will help you plan your equipment rack configuration:

- To ensure adequate air flow through the equipment rack, we recommend that you maintain a clearance of at least 80 mm on each side of the rack at all times.
- If airflow through the equipment rack and the s that occupy it is blocked or restricted, or if the ambient air being drawn into the rack is too warm, an overtemperature condition can occur within the rack and the equipments that occupy it.

- The site should also be as dust-free as possible. Dust tends to clog the chassis fans, reducing the flow of cooling air through the equipment rack and the chassis that occupy it, thus increasing the risk of an overtemperature condition.
- Enclosed racks must have adequate ventilation. Ensure that the rack is not congested, because each equipment generates heat. An enclosed rack should have louvered sides and a fan to provide cooling air. Heat that is generated by the equipment near the bottom of the rack can be drawn upward into the intake ports of the equipment above.
- When mounting a chassis in an open rack, ensure that the rack frame does not block the side intakes and the exhaust fans.
- When rack-installed equipment fails, especially equipment in an enclosed rack, try operating the equipment by itself, if possible. Power off all other equipments in the rack (and in adjacent racks) to give the maximum cooling air and clean power.
- Avoid locating the Cisco NCS 4206 in a location in which the chassis air intake vents may draw in the exhaust air from adjacent equipment. Consider how the air flows through the chassis; the airflow direction is side to side, with ambient air drawn in from the vents located on the front right of the chassis.
- Ensure that cables do not obstruct the air-inlet and air-exhaust grid of the chassis as it may lead to improper ventilation, overheating of the equipment, and dust accumulation.

Air Flow Guidelines for Enclosed Rack Installation

To install a Cisco NCS 4206 in a 4-post enclosed cabinet, the front and rear doors of the cabinet must be removed or be perforated with a minimum of 65% open area.

If you are mounting the chassis in a 4-post enclosed cabinet, ensure that you have a minimum of 6 inches (15.24 cm) of clearance on each side of the chassis.

Floor Loading Considerations

Ensure that the floor under the rack supporting the Cisco NCS 4206s is capable of supporting the combined weight of the rack and all the other installed equipment.

To assess the weight of a fully configured Cisco NCS 4206, see [Cisco Network Convergence System 4200 Series Data Sheet](#).

For additional information about floor loading requirements, consult *GR-63-CORE, Network Equipment Building System (NEBS) Requirements: Physical Protection*.

Site Power Guidelines

The Cisco NCS 4206 has specific power and electrical wiring requirements. Adhering to these requirements ensures reliable operation of the system. Follow these precautions and recommendations when planning your site power for the Cisco NCS 4206:

- The redundant power option provides a second, identical power supply to ensure that power to the chassis continues uninterrupted if one power supply fails or input power on one line fails.
- In systems configured with the redundant power option, connect each of the two power supplies to a separate input power source. If you fail to do this, your system might be susceptible to total power failure due to a fault in the external wiring or a tripped circuit breaker.
- To prevent a loss of input power, be sure that the total maximum load on each circuit supplying the power supplies is within the current ratings of the wiring and the breakers.

- Check the power at your site before installation and periodically after installation to ensure that you are receiving clean power. Install a power conditioner if necessary.
- Provide proper grounding to avoid personal injury and damage to the equipment due to lightning striking power lines or due to power surges. The chassis ground must be attached to a central office or other interior ground system.



Caution This product requires short-circuit (overcurrent) protection, to be provided as part of the building installation. Install only in accordance with national and local wiring regulations.



Note The Cisco NCS 4206 installation must comply with all the applicable codes and is approved for use with copper conductors only. The ground bond fastening hardware should be of compatible material and preclude loosening, deterioration, and electrochemical corrosion of hardware and joined material. Attachment of the chassis ground to a central office or other interior ground system must be made with a 6 AWG gauge wire, copper ground conductor at a minimum.

The maximum power draw of the Cisco NCS 4206 chassis and its configurable hardware components are listed in the following table. The maximum power draw values are not affected by whether the chassis contains 1 or 2 power supplies.

Hardware component(s)	Maximum power draw value
Chassis (2 power supplies, 1 fan tray, and 2 NCS420X-RSP RSP modules)	650W
NCS420X-RSP (active)	240 W
NCS420X-RSP (standby)	240 W
NCS4200-1T8LR-PS (8-port 1GE SFP + 1-port 10 GE interface module)	29 W
NCS4200-8T-PS (8-port 10 Gigabit Ethernet Interface Module)	57 W
NCS4200-1H-PK (1-port 100 Gigabit Ethernet Interface Module)	62 W
NCS4100-Q-P (2-port 40 Gigabit Ethernet QSFP Interface Module)	53 W
NCS4200-1T8S-10C (OC-192 Interface Module + 8-port low rate Interface Module)	92 W
NCS4200-8E1T1-CE (8-port T1/E1 Interface Module)	14.5 W
NCS4200-48T1E1-CE (48-port T1/E1 Interface Module)	35 W
NCS4200-48T3E3-CE (48-port T3/E3 Interface Module)	52 W
NCS4200-1T16G-PS (8/16-port 1 Gigabit Ethernet (SFP/SFP) + 1-port 10 Gigabit Ethernet (SFP+) / 2-port 1 Gigabit Ethernet (CSFP) Interface Module)	54 W
NCS4200-3GMS (1-Port OC48/ STM-16 or 4-port OC-12/OC-3 / STM-1/STM-4 + 12-port T1/E1 + 4-Port T3/E3 CEM Interface Module)	55 W

Hardware component(s)	Maximum power draw value
NCS4200-2H-PQ (1-port 100 GE QSFP interface module)	61 W

Electrical Circuit Requirements

Each Cisco NCS 4206 requires a dedicated electrical circuit. If you equip it with dual power feeds, provide a separate circuit for each power supply to avoid compromising the power redundancy feature.

The Cisco NCS 4206s can be powered by a DC source. Ensure that equipment grounding is present and observe the power strip ratings. Make sure that the total ampere rating of all products plugged into the power strip does not exceed 80% of the rating.

For more information about the Cisco NCS 4206 power supply, see the *Power Supply Features*.

Site Cabling Guidelines

This section contains guidelines for wiring and cabling at your site. When preparing your site for network connections to the Cisco NCS 4206, consider the type of cable required for each component, and the cable limitations. Consider the distance limitations for signaling, electromagnetic interference (EMI), and connector compatibility. Possible cable types are fiber, thick or thin coaxial, foil twisted-pair, or unshielded twisted-pair cabling.

Also consider any additional interface equipment you need, such as transceivers, hubs, switches, modems, channel service units (CSU), or data service units (DSU).

Before you begin, read these important notes about cabling:

- The T1/E1 and T3/E3 interface modules for the Cisco NCS 4206 uses a high-density connector that requires the use of a interface cable and a patch panel. For more information, see *Connecting T1/E1 Cables*.

Before you install the Cisco NCS 4206, have all the additional external equipment and cables on hand. For information about ordering, contact a Cisco customer service representative.

The extent of your network and the distances between the network interface connections depend in part on the following factors:

- Signal type
- Signal speed
- Transmission medium

The distance and rate limits referenced in the following sections are the IEEE-recommended maximum speeds and distances for signaling purposes. Use this information as a guideline in planning your network connections *prior to* installing the Cisco NCS 4206.

If wires exceed the recommended distances, or if wires pass between buildings, give special consideration to the effect of a lightning strike in your vicinity. The electromagnetic pulse caused by lightning or other high-energy phenomena can easily couple enough energy into unshielded conductors to destroy electronic devices. If you have had problems of this sort in the past, you may want to consult experts in electrical surge suppression and shielding.

Asynchronous Terminal Connections

The RSP provides a console port to connect a terminal or computer for local console access. The port has an RJ45 connector and supports RS-232 asynchronous data with distance recommendations specified in the IEEE RS-232 standard.

Interference Considerations

When wires are run for any significant distance, there is a risk that stray signals will be induced on the wires as interference. If interference signals are strong, they can cause data errors or damage to the equipment.

The following sections describe sources of interference and how to minimize its effects on the Cisco NCS 4206 system.

Electromagnetic Interference

All equipment powered by AC current can propagate electrical energy that can cause EMI and possibly affect the operation of other equipment. The typical sources of EMI are equipment power cords and power service cables from electric utility companies.

Strong EMI can destroy the signal drivers and receivers in the Cisco NCS 4206 and even create an electrical hazard by causing power surges through the power lines into installed equipment. These problems are rare but could be catastrophic.

To resolve these problems, you need specialized knowledge and equipment that could consume substantial time and money. However, you can ensure that you have a properly grounded and shielded electrical environment, paying special attention to the need for electrical surge suppression.

For information about the electrode magnetic compliance standards supported on the Cisco NCS 4206, see *Regulatory Compliance and Safety Information for the Cisco NCS 4206*.

Radio Frequency Interference

When electromagnetic fields act over a long distance, radio frequency interference (RFI) may be propagated. Building wiring can often act as an antenna, receiving the RFI signals and creating more EMI on the wiring.

If you use twisted-pair cable in your plant wiring with a good distribution of grounding conductors, the plant wiring is unlikely to emit radio interference. If you exceed the recommended distances, use a high-quality twisted-pair cable with one ground conductor for each data signal.

Lightning and AC Power Fault Interference

If signal wires exceed the recommended cabling distances, or if signal wires pass between buildings, you should consider the effect that a lightning strike in your vicinity might have on the Cisco NCS 4206.

The electromagnetic pulse (EMP) generated by lightning or other high-energy phenomena can couple enough energy into unshielded conductors to damage or destroy electronic equipment. If you have previously experienced such problems, you should consult with RFI and EMI experts to ensure that you have adequate electrical surge suppression and shielding of signal cables in your Cisco NCS 4206 operating environment.

Rack-Mounting Guidelines

The following sections provide guidelines for rack-mounting the Cisco NCS 4206:

Precautions for Rack-Mounting

The following rack-mount guidelines are provided to ensure your safety:

- Do not move large racks by yourself. Due to the height and weight of a rack, a minimum of two people are required to accomplish this task.
- Ensure that the rack is level and stable before extending a component from the rack.
- Ensure that proper airflow is provided to the components in the rack.
- Do not step on or stand on any component or system when servicing other systems or components in a rack.
- When mounting the Cisco NCS 4206 in a partially filled rack, load the rack from the bottom to the top, with the heaviest component at the bottom of the rack.
- If the rack is provided with stabilizing devices, install the stabilizers before mounting or servicing the unit in the rack.

Rack Selection Guidelines

The Cisco NCS 4206 can be mounted in most two-post or four-post, 23-inch equipment racks that comply with the Electronic Industries Association (EIA) standard for equipment racks (EIA-310-D 23-inch). The rack must have at least two posts with mounting flanges to mount the chassis.



Caution When mounting a chassis in any type of rack equipment, ensure that the inlet air to the chassis with plenum does not exceed 55 degrees C.

The distance between the center lines of the mounting holes on the two mounting posts must be 18.31 inches \pm 0.06 inch (46.50 cm \pm 0.15 cm). The rack-mounting hardware included with the chassis is suitable for most 19-inch equipment racks.

Consider installing the Cisco NCS 4206 in a rack with the following features:

- Network Equipment Building System (NEBS) compliant, 19-inch (48.3 cm) wide rack.
- EIA or European Telecommunications Standards Institute (ETSI) hole patterns in the mounting rails. The required mounting hardware is shipped with the Cisco NCS 4206. If the rack that you plan to install the system in has metric-threaded rails, you must provide your own metric-mounting hardware.
- Perforated top and open bottom for ventilation to prevent overheating.
- Leveling feet for stability.



Note The Cisco NCS 4206 should *not* be installed in an enclosed rack because the chassis requires an unobstructed flow of cooling air to maintain acceptable operating temperatures for its internal components. Installing the chassis in any type of enclosed rack—even with the side doors removed—could disrupt the air flow, trap heat next to the chassis, and cause an overtemperature condition inside the chassis. If you use an enclosed rack, ensure that there are air vents on all sides of the rack and there is proper ventilation.

Equipment Rack Guidelines

Choose a proper location for the Cisco NCS 4206 by following the below guidelines.

Locating for Safety

If the Cisco NCS 4206 is the heaviest or the only piece of equipment in the rack, consider installing it at or near the bottom to ensure that the rack's center of gravity is as low as possible.

For additional information about the proper placement of electronic equipment, consult the document *GR-63-CORE, Network Equipment Building System (NEBS) Requirements: Physical Protection*.

Locating for Easy Maintenance

Keep at least 3 feet of clear space at the front and back of the rack. This space ensures that you can remove the Cisco NCS 4206 components and perform routine maintenance and upgrades easily.

Avoid installing the Cisco NCS 4206 in a congested rack and consider how routing of cables from other pieces of equipment in the same rack could affect access to the chassis cards.

The sides of the chassis must remain unobstructed to ensure adequate airflow and prevent overheating inside the chassis.

Allow the following clearances for normal system maintenance:

- At the top of the chassis—At least 3 inches (7.6 cm)
- Sides of the chassis—3 to 4 ft (91.44 cm to 121.92 cm)

To avoid problems during installation and ongoing operations, follow these general precautions when you plan equipment locations and connections:

- Use the **show environment all** command regularly to check the internal system status. The environmental monitor continually checks the interior chassis environment; it provides warnings about high temperature and creates reports on other potentially dangerous occurrences. If warning messages are displayed, take immediate action to identify the cause, and correct the problem.
- Keep the Cisco NCS 4206 off the floor and out of areas that collect dust.
- Follow ESD-prevention procedures to avoid damage to equipment. Damage from static discharge can cause immediate or intermittent equipment failure.

Locating for Proper Airflow

Ensure that the Cisco NCS 4206 location has enough airflow to keep the system operating within the environmental characteristics and the air temperature is sufficient to compensate for the heat dissipated by the system. For more information, see [Air Flow Guidelines](#).

Installation Checklist

To assist you with your installation and to provide a record of what was done by whom and when, photocopy the Cisco NCS 4206 Installation Checklist shown in the table below. Use this to record the completion and verification of each procedure. After the checklist is completed, place it in your Site Log along with the other records pertaining to your new Cisco router.

Table 8: Cisco NCS 4206 Installation Checklist

Task	Verified By	Date
Date on which chassis received		
Chassis and all accessories unpacked		

Task	Verified By	Date
Types and numbers of interfaces verified		
Safety recommendations and guidelines reviewed		
Installation Checklist copied		
Site Log established and background information entered		
Site power voltages verified		
Site environmental specifications verified		
Required passwords, IP addresses, device names, and so on, available		
Required tools available		
Network connection equipment available		
Cable-management brackets installed (optional, but recommended)		
AC power cables connected to AC sources and		
DC power cables connected to DC sources and		
Network interface cables and devices connected		
System power turned on		
System boot complete (STATUS LED is on)		
Shared port adapters are operational		
Correct software configuration displayed after system banner appears		

Creating a Site Log

The Site Log provides a record of all the actions related to installing and maintaining the . Keep it in an accessible place near the chassis so that anyone who performs tasks has access to it.

Create the Site Log prior to the installation. See [Site Log and Manufactures](#) for more information on the Site Log as well as a sample Site Log that can be used to make copies.

Receiving the Cisco NCS 4206

Each Cisco NCS 4206 chassis is shipped in a container. See the figure below.

Figure 37: Cisco NCS 4206 Packaged for Shipping

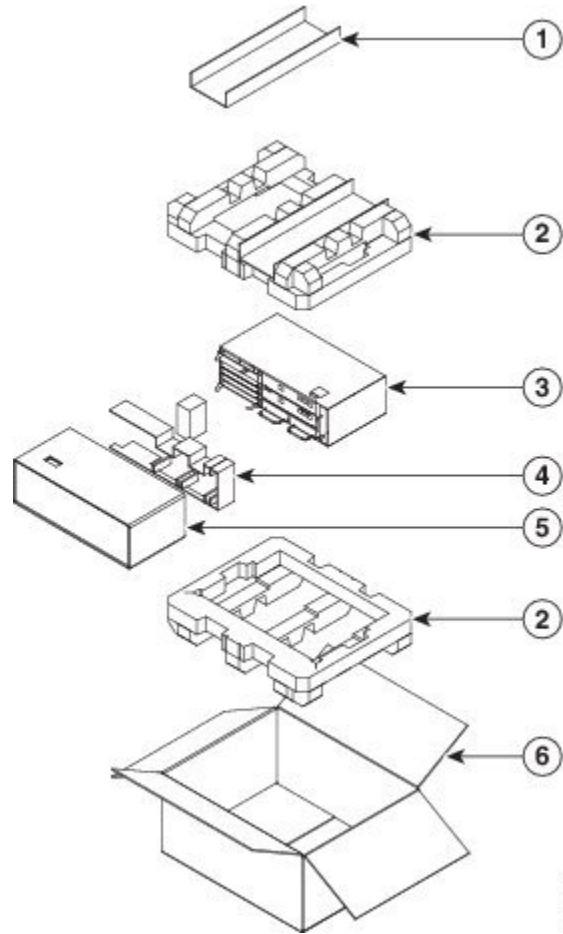

1	Cap of Accessories tray	4	Cisco NCS 4200
2	Accessories tray	5	Packaging Material
3	Packaging Material	6	Packaging Container

391887

Chassis-Lifting Guidelines

The chassis is not intended to be moved frequently. Before you install the system, ensure that your site is properly prepared so that you can avoid having to move the chassis later to accommodate power sources and network connections.

Each time you lift the chassis, follow these guidelines:

- Ensure that your footing is solid, and balance the weight of the chassis between your feet.
- Lift the chassis slowly; never move suddenly or twist your body as you lift.
- Keep your back straight and lift with your legs, not your back. If you must bend down to lift the chassis, bend at the knees, not at the waist, to reduce the strain on your back muscles.
- Do not remove installed components from the chassis.

- Always disconnect all external cables before lifting or moving the chassis.
- Do not carry the chassis in any other packaging except as provided by Cisco packaging. Usage of other inferior packaging for equipment movement may cause severe damage to the product.
- If the equipment is opened for testing purposes, and has to be re-packaged for movement, package it exactly the same way (orientation) as it was previously packaged at the time of product delivery by including all the packaging counter parts. Wrong orientation may cause damage to the product during transportation.
- Always use ESD cover to wrap the hardware before packing it into packaging carton.
- If faulty hardware has to be shipped to RMA depot, use same Cisco packaging which was provided at the time of product delivery.

**Warning**

To prevent personal injury or damage to the chassis, never attempt to lift or tilt the chassis using the handles on modules (such as power supplies, fans, or cards); these types of handles are not designed to support the weight of the unit. Lift the unit only by using handles that are an integral part of the chassis, or by grasping the chassis underneath its lower edge. Statement 163

Tools and Equipment

You need the following tools and equipment to install and upgrade the chassis and its components:

- ESD-preventive cord and wrist strap
- Antistatic mat or antistatic foam
- Number 1 and Number 2 Phillips-head screwdrivers
- Flat-blade screwdrivers: Small 3/16-inch (0.476 cm) and medium 1/4-inch (0.625 cm):
 - To install or remove modules
 - To remove the cover if you are upgrading the memory or other components
- #12-24 pan-head screws to secure the chassis to the equipment rack
- Cables for connecting to the WAN and LAN ports (depending on the configuration)

**Note**

For more information on cable specifications, see [Troubleshooting](#).

- Ethernet hub or switch or PC with a network interface card for connecting to the Ethernet ports
- Console terminal (an ASCII terminal or a PC running terminal emulation software) that is configured for 9600 baud, 8 data bits, no parity, and 2 stop bits
- Console cable for connecting to the console port
- (Optional) Modem for connecting to the auxiliary port for remote administrative access
- Auxiliary cable for connecting to the auxiliary port (you can supply this cable or order one)
- Ratcheting torque screwdriver with a Phillips head that exerts up to 30 pound-force per square inch (in-lb) of pressure
- Crimping tool as specified by the ground lug manufacturer
- 18 AWG copper wire for the power cord
- Wire-stripping tools for stripping both 6 AWG and 18 AWG wire
- Tape measure and level



Warning Only trained and qualified personnel should be allowed to install or replace this equipment. Statement 49

Unpacking and Verifying the Shipped Contents

When you receive your chassis, perform the following steps and use the Shipping Contents Checklist:

Procedure

- Step 1** Inspect the box for any shipping damage. If there is obvious physical damage, contact your Cisco service representative.
- Step 2** Unpack the Cisco NCS 4206.
- Step 3** Perform a visual inspection of the chassis.
- Step 4** Use the table below to check the contents of the Cisco NCS 4206 shipping container. Do not discard the shipping container. You will need the container if you move or ship the Cisco NCS 4206 in the future.

What to do next

Table 9: Cisco NCS 4206 Shipping Container Contents

Component	Description
Chassis	Cisco NCS 4206 chassis (PN: NCS4206-SA)
	Fan tray (PID: A903-FAN-H)
	Power supplies (PID: A900-PWR1200-D)
	RSP (PID: NCS420X-RSP)
	Interface modules (see Table 1-1)
NCS 4206 DC Starter Kit (PID: NCS4206D-STRT-KIT)	Cisco NCS 4206 chassis (PN: NCS4206-SA) Door (PID: NCS4206-DOOR) Fan tray (PID: A903-FAN-H) Power supplies (PID: A900-PWR1200-D) RSP (PID: NCS420X-RSP) Chassis rack-mount brackets (23-inch EIA) (PID: A903-RCKMNT-23IN)

Component	Description
Accessories kit	Chassis rack-mount brackets (23-inch EIA) (PID: A903-RCKMNT-23IN)
	Three sets of screws: <ul style="list-style-type: none"> • Front and rear rack-mount bracket screws (2 sets) • Cable-management bracket screws
	Six cable-management brackets (one per bracket)
	One earth lug with two 10-32 screws.
	1 RJ45 to RJ45 crossover cable 1 RJ45 to DB-9 (female) adapter
ESD, wrist strap (disposable)	One disposable wrist strap (optional)
Documentation	<i>Regulatory Compliance and Safety Information for the</i> Cisco NCS 4206
Optional equipment	Check the container for the following optional equipment: <ul style="list-style-type: none"> • There are no cords for the DC power supply units. • T1/E1 or T3/E3 cable connector (required only for T1/E1 or T3/E3 interface modules)



Note Most Cisco documentation is available online. Documentation that is shipped with your Cisco NCS 4206 includes the *Regulatory Compliance and Safety Information for the* Cisco NCS 4206 document, and the Cisco NCS 4206 Documentation Roadmap that contains information about the various documents that are available online and the links to them.



CHAPTER 3

Installing the Cisco NCS 4206

This chapter describes how to install the Cisco NCS 4206 and includes the following sections:

- [Prerequisites, on page 51](#)
- [Installing the Chassis in a Rack, on page 51](#)
- [Installing the Chassis Ground Connection, on page 60](#)
- [Installing the Fan Tray, on page 62](#)
- [RSP Installation, on page 67](#)
- [Interface Module Installation, on page 71](#)
- [Installing the Power Supply, on page 74](#)
- [Installing the AC power Supply, on page 80](#)
- [Power Cable Bracket \(A9XX-PWR-CBL-MGMT\), on page 83](#)
- [Top Cable Management Bracket \(A9XX-TOP-CBL-MGMT\), on page 85](#)
- [Connecting the Cisco NCS 4206 to the Network, on page 87](#)

Prerequisites

Before installing the Cisco NCS 4206, it is important to prepare for the installation by:

- Preparing the site (site planning) and reviewing the installation plans or method of procedures (MOP)
- Unpacking and inspecting the Cisco NCS 4206
- Gathering the tools and test equipment required to properly install the Cisco NCS 4206

For more instructions on how to prepare for the installation of the Cisco NCS 4206, see [Preparing for Installation](#).

Installing the Chassis in a Rack

The following sections describe how to install the Cisco NCS 4206 in a rack.

Installing the Chassis Brackets

The chassis is shipped with mounting brackets that can be installed on the front or rear of the chassis. To install the brackets on the front of the chassis, perform these steps:

Procedure

Step 1 Remove the rack-mount brackets from the accessory kit and position them beside the chassis.

Figure 38: Attaching Mounting Brackets for a 19-inch Rack (A903-RCKMNT-19IN3)

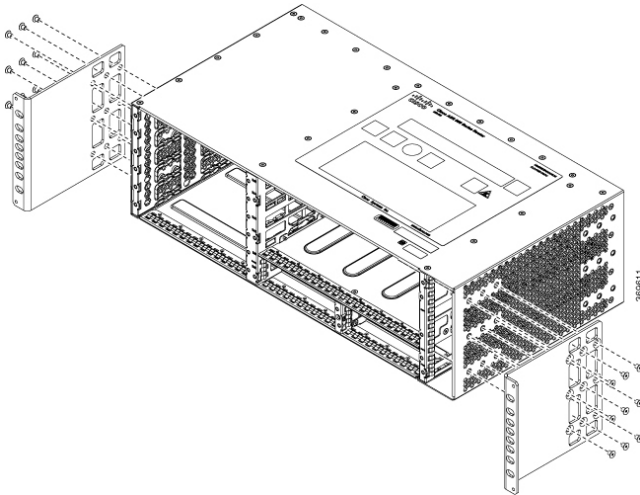
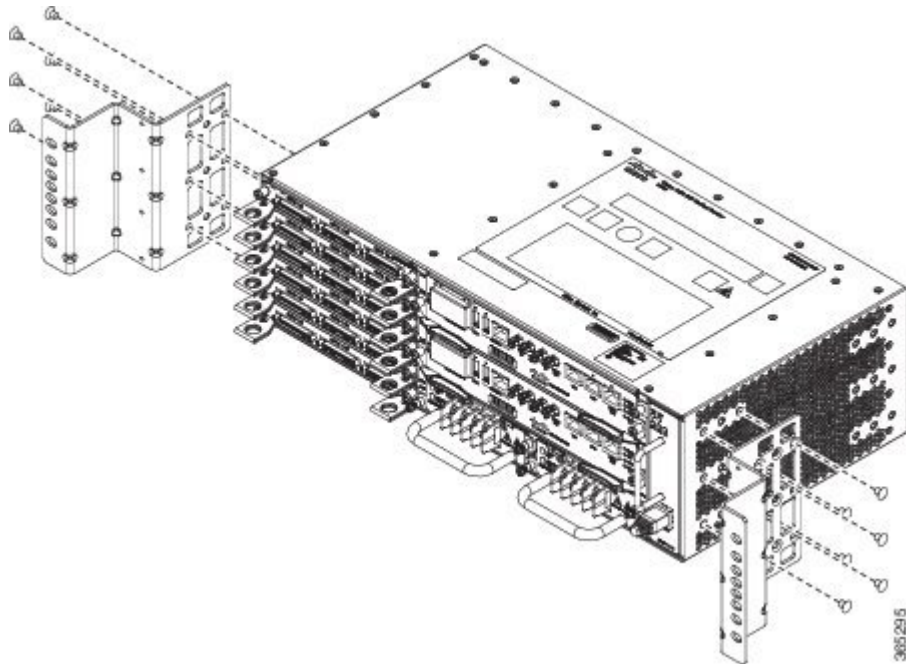

Figure 39: Attaching Mounting Brackets for a 23-inch EIA Rack



Step 2 Position one of the brackets against the chassis side, and align the screw holes.

Step 3 Secure the bracket to the chassis with the screws removed when performing Step 1. The recommended maximum torque is 28 in.-lb (3.16 N-m).

Step 4 Repeat Step 2 and Step 3 for the other bracket.

Installing the Chassis in the Rack

The procedures in this section apply to both horizontal and vertical mounting of the in a rack.

To install the chassis in the equipment rack, perform these steps:

Procedure

Step 1 Position the chassis in the rack as follows:

- If the front of the chassis (front panel) is at the front of the rack, insert the rear of the chassis between the mounting posts.
- If the rear of the chassis is at the front of the rack, insert the front of the chassis between the mounting posts.

Step 2 Guide the chassis carefully into the plenum assembly. See the figure below.

Figure 40: Installing the Chassis on a 19-inch Rack (A903-RCKMNT-19IN3)

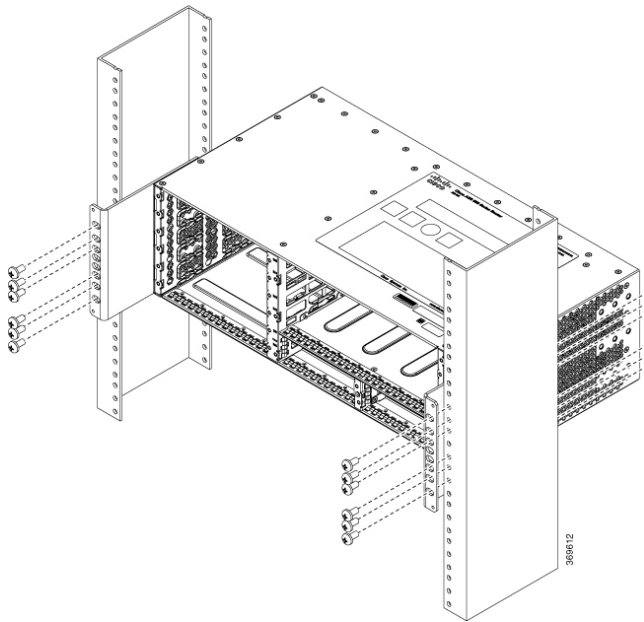
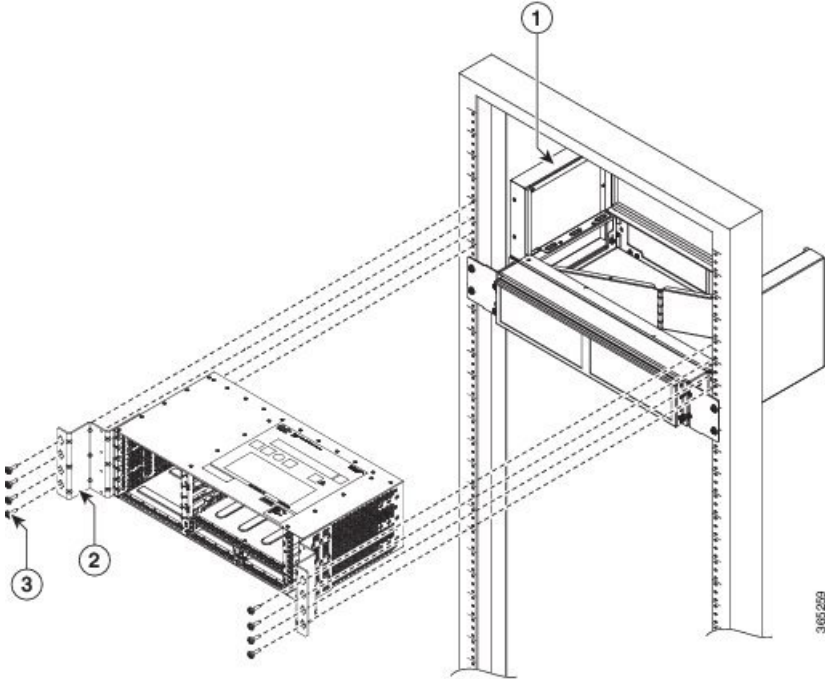

Figure 41: Installing the Chassis on the Plenum in Rack



1	Plenum	3	Securing screws to chassis onto rack
2	Cable guides on chassis	—	

Step 3 Position the door onto the chassis and slide it into the rack. Secure the screws with a torque of n.-lb (N-m). See the figure below.

Figure 42: Installing Door onto Chassis in Rack

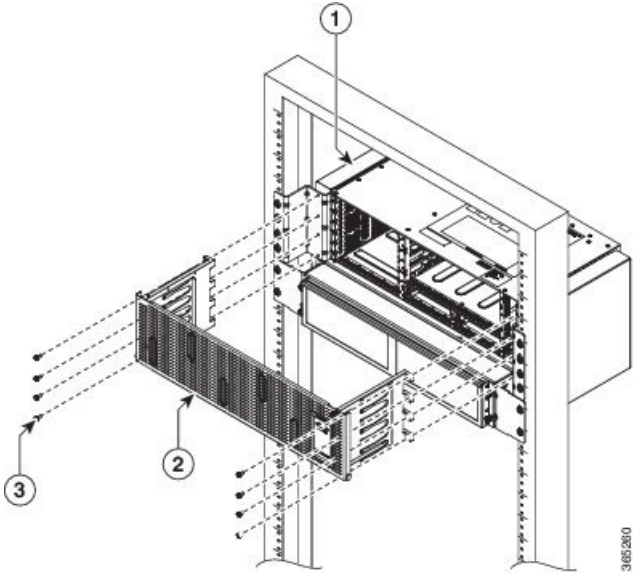

1	Chassis in plenum	3	Securing door to the chassis onto rack
2	Door	—	

Step 4 Align the mounting holes in the bracket (and optional cable guide) with the mounting holes in the equipment rack.

Caution Do not use interface module and power supply ejector handles to lift the chassis; using the handles to lift the chassis can deform or damage the handles.

Figure 43: Installing the Chassis in a 23-inch EIA Rack

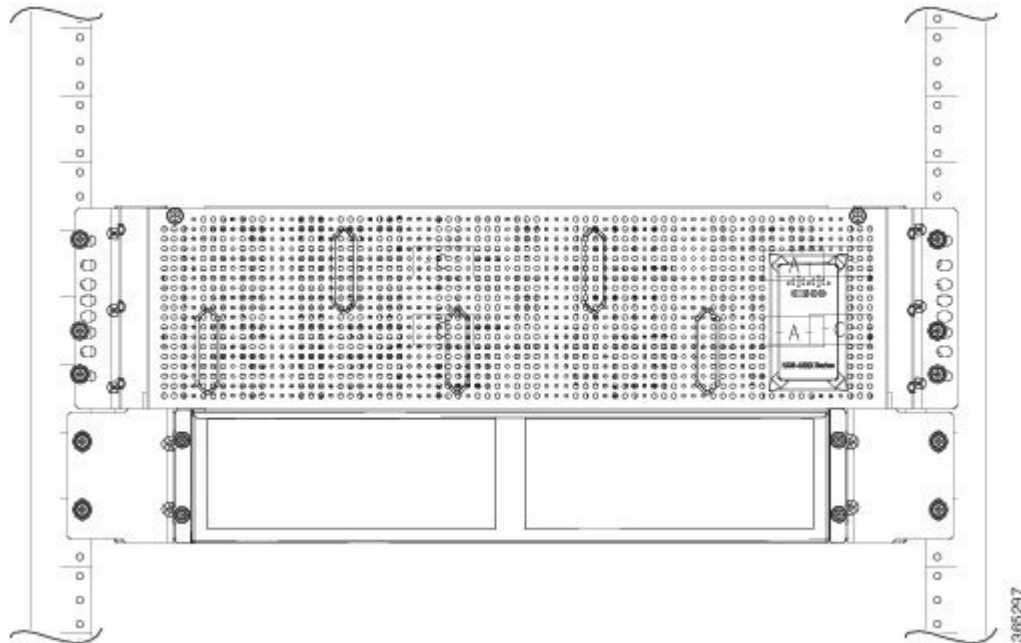

Step 5 Install the 8 or 12 (4 or 6 per side) 12-24 x 3/4-inch or 10-32 x 3/4-inch screws through the holes in the bracket and into the threaded holes in the equipment rack posts.

Step 6 Use a tape measure and level to verify that the chassis is installed straight and level.

Installing the Chassis with Plenum in Rack

Procedure

Step 1 Position the air baffle and the side plate to the plenum. See figure below.

Figure 44: Securing the Air Baffle Tray

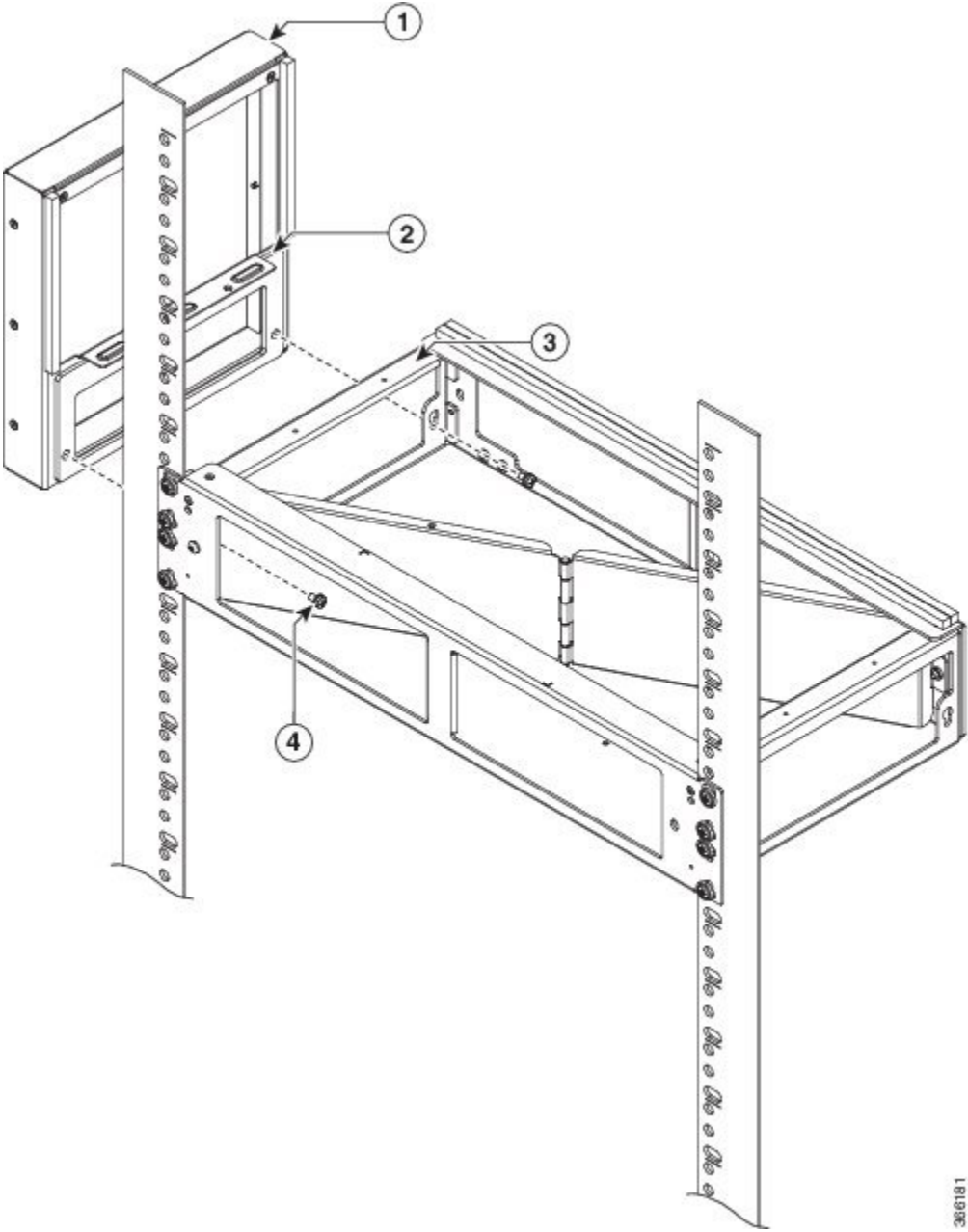

1	Air baffle	3	Plenum base
2	Side plate	4	Secure screw to Plenum base

Step 2 Secure the air baffle and the side plate using a maximum torque of 11.5 in.-lb (1.3 N-m). See figure below.

Figure 45: Securing the Side Plate

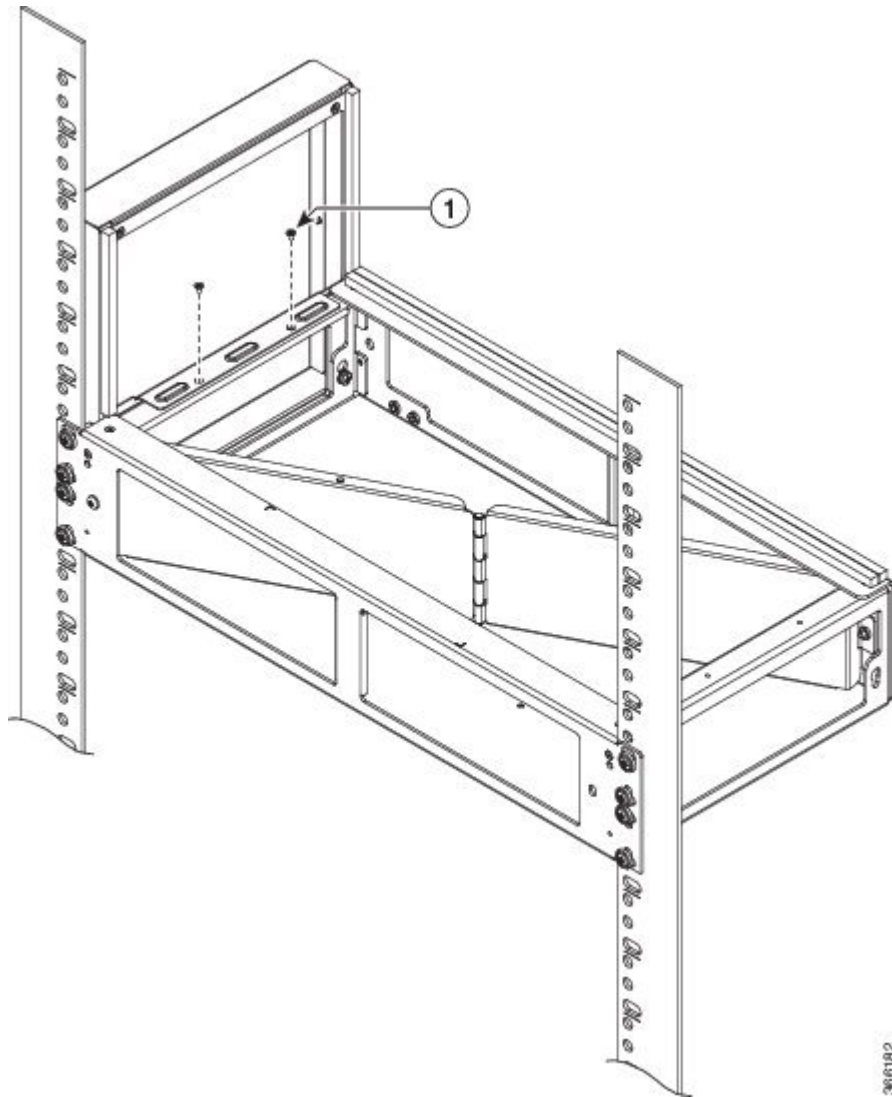

1	Securing side plate to plenum base	—	—
---	------------------------------------	---	---

Step 3 Repeat Step-1 and Step-2 to complete the plenum assembly on the other side of the plenum base.

Step 4 Position the air filter (A903-F2B-AIR-F) assembly on the plenum deflector. Secure the front cover using a recommended torque of 11.5 in.-lb (1.3 N-m). See figure below.

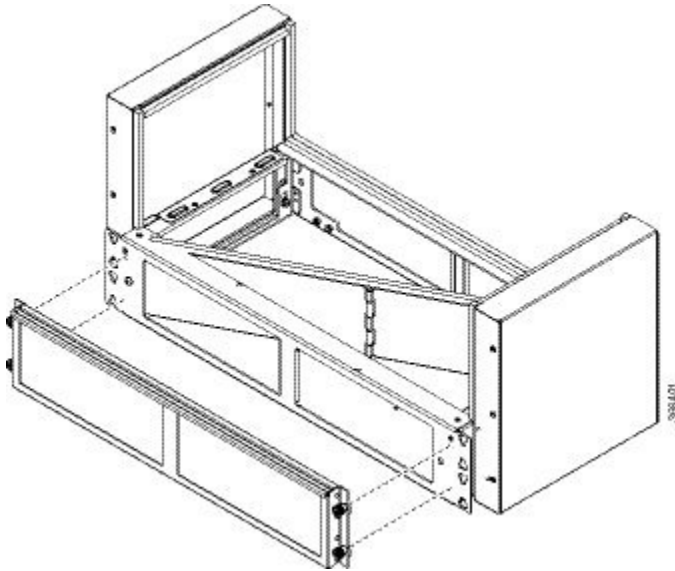
Figure 46: Air Filter

Note The filter is applicable when fan A903-FAN-H is used.

Step 5 Using a crimping tool (as specified by the ground lug manufacturer), crimp the ground lug to the ground wire and connect the other end of the ground wire to a suitable grounding point at your site. See figure below.

Figure 47: Attaching the Ground Lug and Wire Assembly

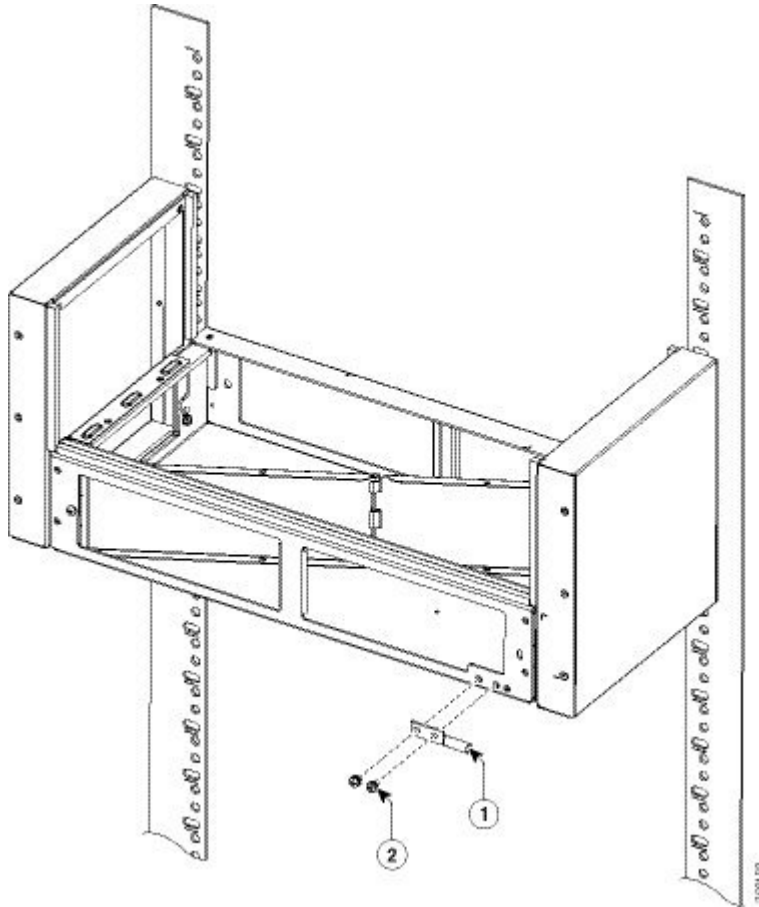

1	Dual-hole ground adapter and dual-hole lug	2	Dual ground screws
---	--	---	--------------------

Step 6 Position the plenum assembly to the rack and secure the cable brackets to the rack using a torque of 11.5 in.-lb (1.3 N-m). See figure below.

Installing the Chassis in the Air Plenum



Note Ensure that the chassis is not installed in the air plenum while mounting it on the rack.

For instructions on mounting the plenum on the rack:

Procedure

Step 1 Position the chassis so that the rear of the chassis is at the front of the plenum.

Step 2 Slide the chassis into the plenum so that the front of the chassis is in flush with the mounting rails and brackets. See the figure below.

Figure 48: Cisco NCS 4206 Chassis with Plenum

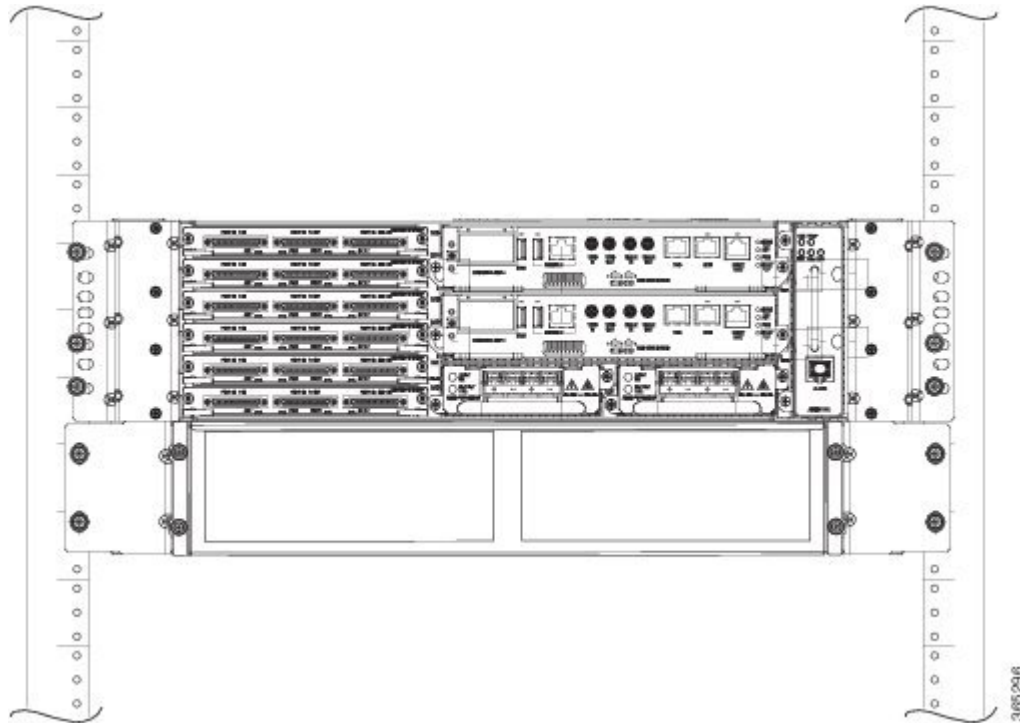

Installing the Chassis Ground Connection

Before you connect the power or turn on the power to the Cisco NCS 4206, you must provide an adequate chassis ground (earth) connection to your chassis.

This section describes how to ground the Cisco NCS 4206 chassis on a rack. The chassis provides two locations for attaching a 2-hole grounding lug according to the rack-mounting brackets you use to install the chassis. The Cisco NCS 4206 supports the following rack-mounting types:

- EIA 23-inch rack—Attach the grounding lug to the rack, as shown in the figure below

Figure 49: Attaching a Grounding Lug

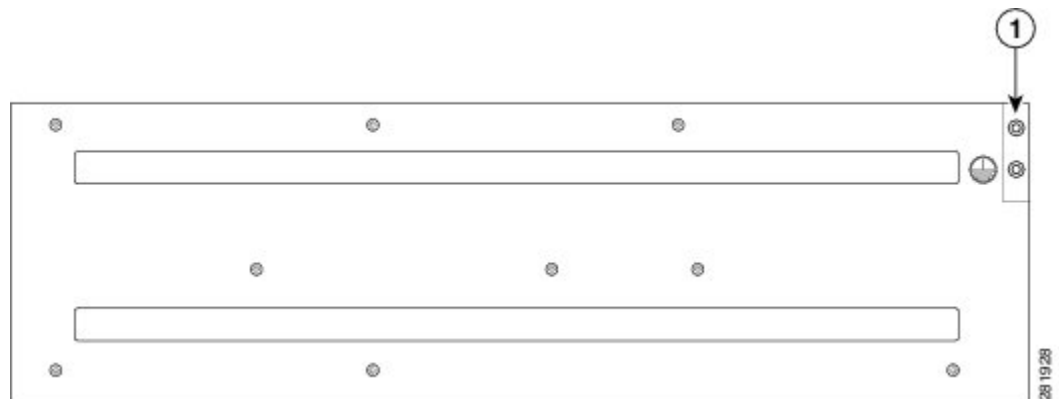

1	Grounding lug
---	---------------

To ensure that the chassis ground connection that you provide is adequate, you need the following parts and tools:

- Ratcheting torque screwdriver with Phillips head that exerts up to 15 in.-lb (1.69 N-m) of pressure for attaching the ground wire to the router
- Crimping tool as specified by the ground lug manufacturer
- 18 AWG copper wire for the power cord
- 6 AWG or larger copper wire for the ground wire
- Wire-stripping tools appropriate to the wire you are using



Caution Before making connections to the Cisco NCS 4206, ensure that you disconnect the power at the circuit breaker. Otherwise, severe injury to you or damage to the chassis may occur.



Warning This equipment must be grounded. Never defeat the ground conductor or operate the equipment in the absence of a suitably installed ground conductor. Contact the appropriate electrical inspection authority or an electrician if you are uncertain that suitable grounding is available. Statement 1024



Warning Use copper conductors only. Statement 1025



Warning When installing the unit, the ground connection must always be made first and disconnected last. Statement 42

This unit is to be installed in a restrictive access location and must be permanently grounded to minimum 6 AWG copper ground wire.

Perform the following procedure to ground the Cisco NCS 4206 using a 2-hole lug and the corresponding mounting point. Most carriers require a minimum 6 AWG ground connection. Verify your carrier's requirements for the ground connection.

Procedure

- Step 1** If your ground wire is insulated, use a wire-stripping tool to strip the ground wire to 0.5 inch \pm 0.02 inch (12.7 mm \pm 0.5 mm) (as shown in the figure below).

Figure 50: Stripping a Ground Wire

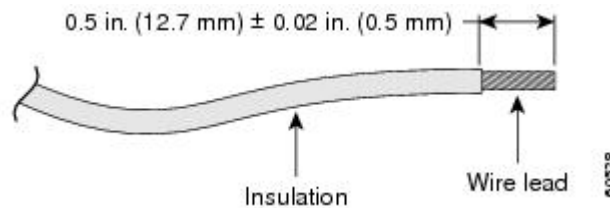

- Step 2** Slide the open end of your 2-hole ground lug over the exposed area of the ground wire.
- Step 3** Using a crimping tool (as specified by the ground lug manufacturer), crimp the ground lug to the ground wire as shown in the figure below.

Figure 51: Crimping a Ground Lug onto the Ground Wire

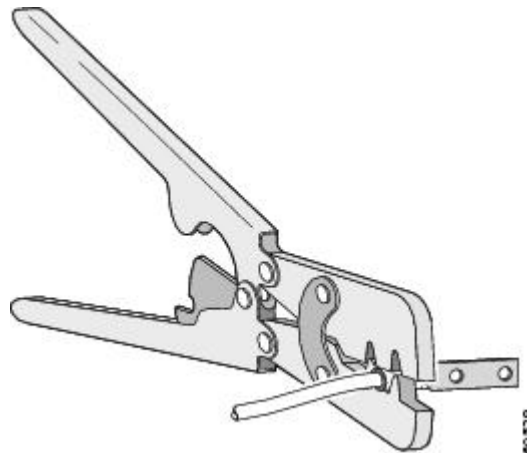

- Step 4** Use a Phillips head screwdriver to attach the 2-hole ground lug and wire assembly to the chassis with the 2 pan-head Phillips head screws. For a 19-inch EIA rack, attach the 2-hole ground lug to the rear of the router.
- Step 5** Connect the other end of the ground wire to a suitable grounding point at your site.

Installing the Fan Tray

The fan tray is a modular unit that provides cooling to the Cisco NCS 4206. Follow these steps to install the fan tray in the chassis:

Procedure

- Step 1** Orient the fan tray so that the captive screws are on the left side of the fan tray's front panel. The figure below shows how to orient the fan tray.

Figure 52: Installing the Fan Tray

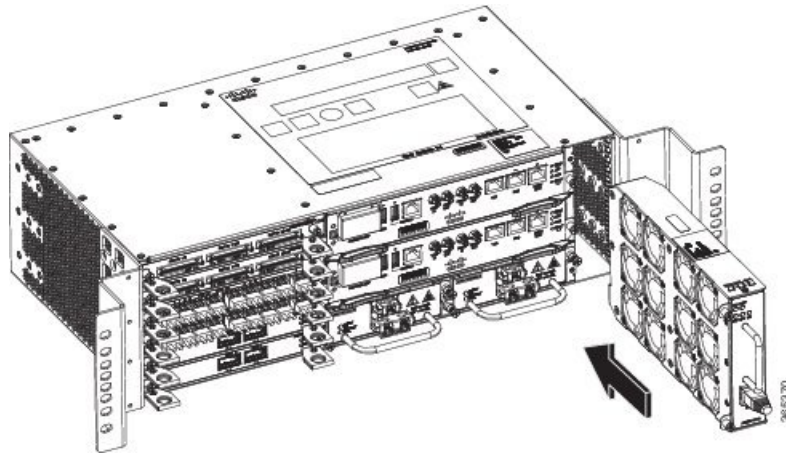

- Step 2** Guide the fan tray into the chassis until it is fully seated.

Caution The fans are exposed on the left side of the fan tray. Keep your fingers, clothing, and jewelry away from the fans. Always handle the fan tray by the handle.

Note When installing the cabling to the RSPs, we recommend that you leave a service loop of extra cabling sufficient to allow for fan tray removal.

- Step 3** Secure the fan tray to the chassis using the attached captive installation screws. The recommended maximum torque is 5.5 in.-lb (.62 N-m).

This completes the procedure for installing or replacing the fan tray in a Cisco NCS 4206.

For information about connecting cables to the fan tray alarm port, see [Connecting the Fan Tray Alarm Port](#).

For a summary of the LEDs on the fan tray, see [LED Summary](#).

For more information about air flow guidelines, see [Air Flow Guidelines](#).

Installing the Dust Filter

Procedure

- Step 1** Follow the steps for removing the fan tray (if installed) from the chassis.
- Step 2** Remove the dummy cover from the fan tray.

- Step 3** Slide the dust filter onto the fan tray.
- Step 4** Insert the dummy cover on the fan tray to secure the filter within the chassis.
- Step 5** Follow the steps to install the fan tray in the chassis.
-

Removing the Dust Filter

Remove the dust filter for a replacement.



Note

- The dust filter is a single-use component.
 - Use the dust filter (A903-FAN-F) within 6 months of buying as the shelf or storage life is less than 6 months. The ideal storage condition for a filter is a cool, dry, and dark environment. Surroundings that adversely affect the dust filter are high heat, humidity at high temperatures, and ultraviolet light.
-

Dust Filter Maintenance

A periodic health check of the filter, every three months based on the level of dust in the environment, helps in avoiding over clogging of the filters and provide a better life. This product's filter is used as a single-use component. If the product is installed in a controlled environment, check and replace the filter every three months, otherwise replace the filter every month.

Procedure

- Step 1** Remove the dummy cover from the fan tray.
- Step 2** Remove the dust filter from the fan.
- Note** The filter can be accessed by pulling the pull tab by using fingers or pliers.
- Step 3** Slide the replacement dust filter onto the fan tray
- Step 4** Insert the dummy cover onto the fan tray to secure the filter within the chassis.
-

Removing and Replacing the Fan Tray

The fan tray supports online insertion and removal (OIR). There is no need to power down the Cisco NCS 4206 to remove or replace the fan tray. However, there is a finite time to replace the fan tray. This time depends upon the specific RSP and fan tray combination and also the ambient temperature. The following table provides the time interval for replacing the fan tray. At higher ambient temperatures, the replacement time is lower.



Note If a fan tray is removed and not replaced within the stipulated time the system will automatically power-off. If the system is powered with PSUs other than 900W DC or 1200W AC and if the system is powered off, then the system should be completely powered off for 30 seconds with all the PSU in the system simultaneously, and then turned on for the system to power on.

Table 10: Fan Tray OIR

Temperature °C at 1800 m	OIR Interval
-40 to 15	2 minutes 10 seconds
16 to 20	100 seconds
21 to 30	90 seconds
31 to 40	40 seconds
>41	Not Applicable



Note If the fan tray is removed and *not* replaced within the stipulated time, then the system will automatically power off. If the system is powered off, the AC or the DC input should be turned off for at least 30 seconds for all the PSU in the system simultaneously, and then turned on for the router to power on.



Caution To avoid erroneous failure messages, allow at least 2 minutes for the system to reinitialize after the fan tray has been replaced.

Follow these steps to remove and replace the fan tray on the Cisco NCS 4206:

Procedure

Step 1 Using a No. 2 Phillips screwdriver or your fingers, loosen the captive installation screw that secures the fan tray to the chassis. The figure below shows the front of the fan tray, including the captive installation screws.

Figure 53: Detaching the Fan Tray

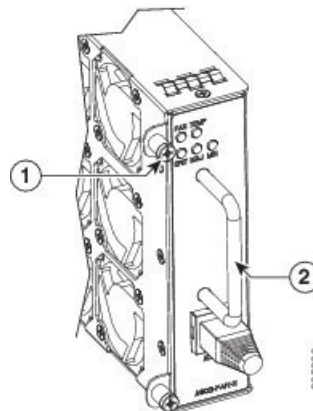

1	Captive installation screw	2	Handle
---	----------------------------	---	--------

Step 2 Grasp the fan tray handle with one hand and the outside of the chassis with the other hand. The figure below shows the front of the fan tray, including the handle.

Caution The fans are exposed on the left side of the fan tray. Keep your fingers, clothing, and jewelry away from the fans. Always handle the fan tray by the handle.

Step 3 Pull the fan tray backward toward you no more than 1 inch to disengage it from the power receptacle on the midplane, as shown in the figure below.

When removing the fan tray, keep your hands and fingers away from the spinning fan blades. Let the fan blades completely stop before you remove the fan tray. Statement 258

Figure 54: Fan Tray Removal

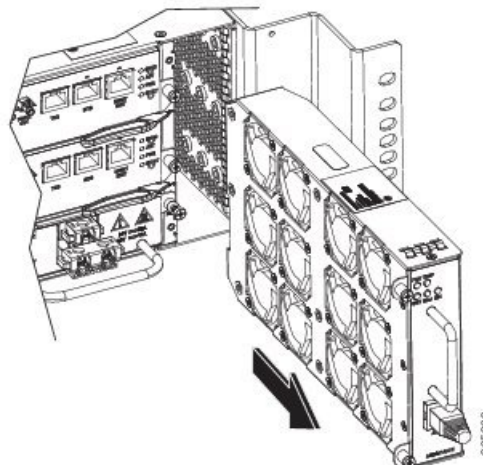

Step 4 Wait at least 5 seconds to allow the fans to stop spinning. Then, pull the fan tray backward toward you and out of the chassis.

Note As the fan tray slides out of the chassis, support the bottom of the fan tray with one hand and keep your other hand on the fan tray handle.

This completes the steps for removing the fan tray from the chassis.

To install the new fan tray, follow the steps in [Installing the Fan Tray](#).

RSP Installation

Follow these steps on handling an RSP module in the Cisco NCS 4206:

Installing an RSP Module

To install an RSP module in the chassis, perform the following steps:

Procedure

Step 1 Choose a slot for the module. Ensure that there is enough clearance to accommodate any equipment that will be connected to the ports on the module. If a blank module filler plate is installed in the slot in which you plan to install the module, remove the plate by removing its 2 Phillips pan-head screws.

Step 2 Fully open both the ejector levers on the new module, as shown in the figure below.

Caution To prevent ESD damage, handle modules by carrier edges only.

Step 3 Position the module in the slot. Make sure that you align the sides of the module with the guides on each side of the slot, as shown in the figure below.

Figure 55: Cisco NCS 4206 RSP Installation

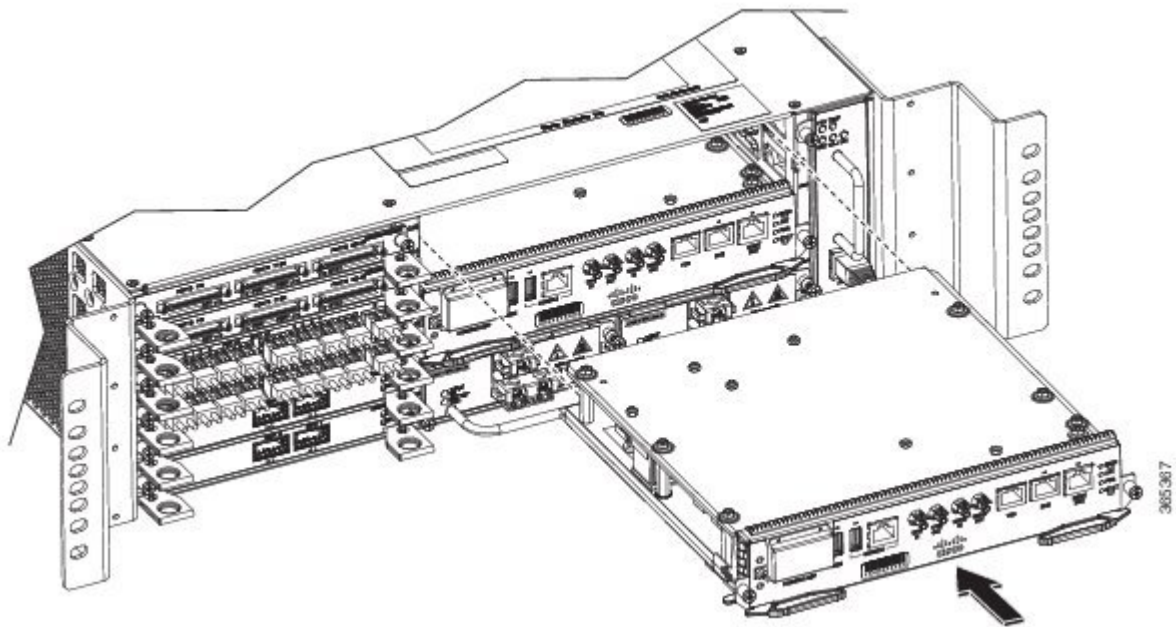

Step 4 Carefully slide the module into the slot until the EMI gasket on the module makes contact with the module in the adjacent slot and both the ejector levers have closed to approximately 45 degrees with respect to the module faceplate.

Caution If the top slot already has an RSP module installed, and you install a second RSP module in the slot below it, be careful not to damage the EMI gasket of the bottom RSP module against the ejector levers of the top RSP during insertion.

Step 5 While pressing down, simultaneously close both the ejector levers to fully seat the module in the backplane connector. The ejector levers are fully closed when they are flush with the module faceplate.

Step 6 Tighten the two captive installation screws on the module. The recommended maximum torque is 5.5 in.-lb (.62 N-m).

Note Make sure that the ejector levers are fully closed before tightening the captive installation screws.

Step 7 Verify that the captive installation screws are tightened on all of the modules installed in the chassis. This step ensures that the EMI gaskets on all the modules are fully compressed in order to maximize the opening space for the new or replacement module.

Note If the captive installation screws are loose, the EMI gaskets on the installed modules will push adjacent modules toward the open slot, which reduces the size of the opening and makes it difficult to install the new module.

Note Blank module filler plates (Cisco part number A900-RSPA-BLANK) should be installed in any empty chassis slots to keep dust out of the chassis and to maintain consistent airflow through the chassis.

Note When installing the cabling to an RSP, we recommend that you leave a service loop of extra cabling sufficient to allow for fan tray removal.

Removing an RSP Module

Before you remove an RSP from the chassis, you should save the current configuration using the **write {host file | network | terminal}** command. This saves you time when bringing the module back online.

If the module is running Cisco IOS software, save the current running configuration by entering the **copy running-config startup-config** command.



Warning Hazardous voltage or energy is present on the backplane when the system is operating. Use caution when servicing. Statement 1034



Warning Invisible laser radiation may be emitted from disconnected fibers or connectors. Do not stare into beams or view directly with optical instruments. Statement 1051

To remove an RSP module, perform the following steps:

Procedure

Step 1 Disconnect any cables attached to the ports on the module.

Step 2 Verify that the captive installation screws on all the modules in the chassis are tight. This step ensures that the space created by the removed module is maintained.

Note If the captive installation screws are loose, the EMI gaskets on the installed modules will push the modules toward the open slot, which in turn reduces the size of the opening and makes it difficult to remove the module.

Step 3 Loosen the two captive installation screws on the module you plan to remove from the chassis.

Step 4 Place your thumbs on the ejector levers and simultaneously rotate the ejector levers outward to unseat the module from the backplane connector.

Step 5 Grasp the front edge of the module and slide the module straight out of the slot. If the chassis has horizontal slots, place your hand under the module to support its weight as you slide it out from the slot. Do not touch the module circuitry.

Caution To prevent ESD damage, handle modules by the carrier edges only.

Step 6 Place the module on an antistatic mat or antistatic foam, or immediately reinstall the module in another slot.

Step 7 Install blank module filler plates (Cisco part number A900-RSPA-BLANK) in empty slots, if any.

Warning Blank faceplates and cover panels serve three important functions: they prevent exposure to hazardous voltages and currents inside the chassis; they contain electromagnetic interference (EMI) that might disrupt other equipment; and they direct the flow of cooling air through the chassis. Do not operate the system unless all cards, faceplates, front covers, and rear covers are in place. Statement 1029

Installing the Wire Wrap Adapter

The wire wrap adapter is used to support the wire wrap interface for the BITS port on the RSP3 module. This adapter is plugged into the existing RJ-45 connector on the RSP3 module.

Figure 56: Wire Wrap Adapter

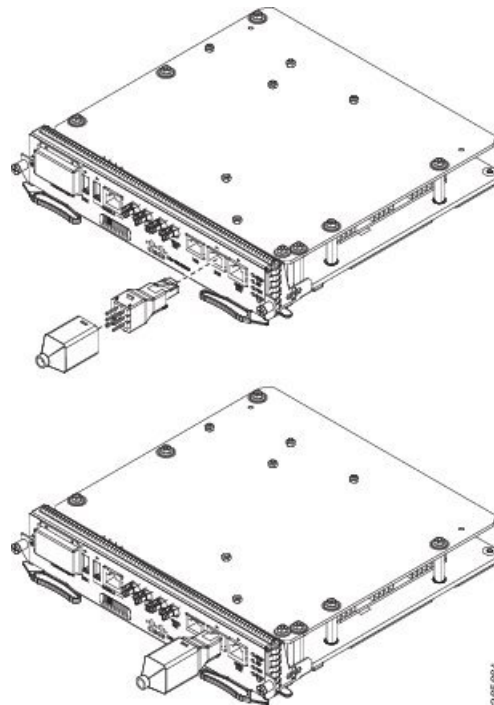

For information on pinouts, see [Wire Wrap Adapter Pinouts](#).

Hot-Swapping an RSP Module

The Cisco NCS 4206 provides a feature that allows you to remove and replace a redundant RSP module without powering down the chassis. This feature, called hot-swapping or OIR, allows you to remove and replace a redundant module without disrupting chassis operation.

When two redundant modules are installed in the chassis, only one of the modules is active. The other one runs in standby mode, ready to take over processing if the active module fails.

When you remove or insert a redundant module while the chassis is powered on and running, the chassis does the following:

1. Determines if there is sufficient power for the module.
2. Scans the backplane for configuration changes.
3. Initializes the newly inserted module. In addition, the system notes any removed modules and places those modules in the administratively shutdown state.
4. Places any previously configured interfaces on the module back to the state they were in when they were removed. Any newly inserted interfaces are put in the administratively shutdown state as if they were present (but unconfigured) at boot time. If you insert the same type of module into a slot, its ports are configured and brought online up to the port count of the original module.

The chassis runs diagnostic tests on any new interfaces and the test results indicate the following:

- If the tests pass, the chassis is operating normally.
- If the new module is faulty, the chassis resumes normal operation but leaves the new interfaces disabled.
- If the diagnostic tests fail, the chassis stops operating, which usually indicates that the new module has a problem in the bus and should be removed.

Interface Module Installation

The following sections describe the various tasks of associated with interface module installation on the Cisco NCS 4206.

Installing an Interface Module

Procedure

-
- Step 1** Before inserting an interface module, make sure that the chassis is grounded.
- Step 2** To insert the interface module, carefully align the edges of the interface module between the upper and lower edges of the chassis slot.
- Step 3** Carefully slide the interface module into the chassis slot until the interface module makes contact with the backplane. The figure below shows how to install the interface module.

Figure 57: Inserting an Interface Module

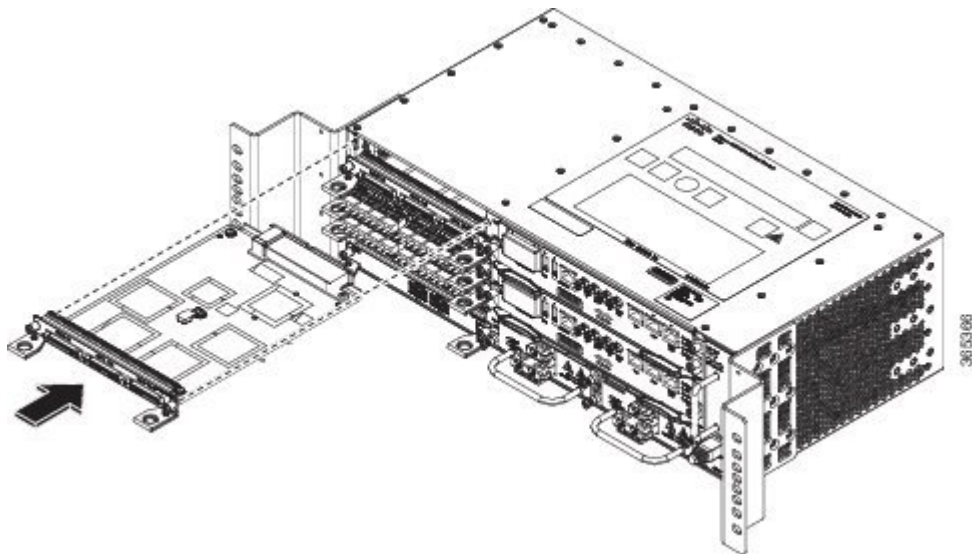

- Caution** Use the pull tab on the interface module only to insert and pull the card out straightly. Don't use the pull tab to turn on its axis or bend it up or down, which can deform or damage the pull tab.

Figure 58: Using the Pull Tab

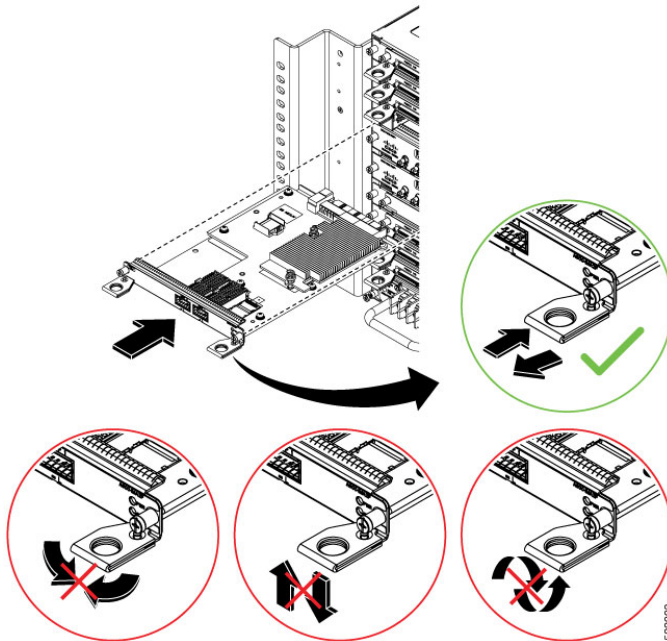

- Step 4** Tighten the locking thumbscrews on both sides of the interface module. The recommended maximum torque is 5.5 in.-lb (.62 N-m).
- Step 5** Connect all the cables to each interface module.

What to do next



Caution Do not use interface module and power supply ejector handles to lift the chassis; using the handles to lift the chassis can deform or damage the handles.

Removing an Interface Module

Procedure

- Step 1** To remove an interface module, disconnect all the cables from each interface module.
- Step 2** Loosen the locking thumbscrews on both sides of the interface module.
- Step 3** Slide the interface module out of the slot by pulling on the handles. If you are removing a blank filler plate, pull the blank filler plate completely out of the slot using the captive screws.

Hot-Swapping an Interface Module

The Cisco NCS 4206 router provides a feature that allows you to remove and replace an interface module without powering down the router. This feature, called hot-swapping or OIR, allows you to remove and replace a redundant module without disrupting chassis operation.

Use the following guidelines when performing an OIR on an IM:

- Avoid inserting a new IM during bootup until the active and standby RSPs have reached an OK state.
- When inserting multiple IMs into the chassis, wait until each IM reaches an OK state before inserting the next IM.

When you remove or insert a redundant module while the chassis is powered on and running, the chassis does the following:

1. Determines if there is sufficient power for the module.
2. Scans the backplane for configuration changes.
3. Initializes the newly inserted module. In addition, the system notes any removed modules and places those modules in the administratively shutdown state.
4. Places any previously configured interfaces on the module back to the state they were in when they were removed.

The runs diagnostic tests on any new interfaces and the test results indicate the following:

- If the tests pass, the is operating normally.
- If the new module is faulty, the resumes normal operation but leaves the new interfaces disabled.
- If the diagnostic tests fail, the stops operating, which usually indicates that the new module has a problem in the bus and should be removed.



Caution

To avoid erroneous failure messages, note the current configuration of all interfaces before you remove or replace an interface module, and allow at least 2 minutes for the system to reinitialize after a module has been removed or replaced. This time is recommended in order to allow for synchronization between components within the interface module and for synchronization with the standby RSP.



Note

Always refer to Interface Module compatibility matrix tables in the Data Sheet before you swap any IM.

Table 11: Supported Hot Swapping Combinations

Interface Modules	NCS420X-RSP
	Cisco IOS Release 3.18

Interface Modules	NCS420X-RSP
SFP Combo IM—8-port Gigabit Ethernet (8X1GE) + 1-port 10 Gigabit Ethernet (1X10GE)	Swapping allowed on all Ethernet interface modules
8-port 10 Gigabit Ethernet Interface Module (8X10GE)	
1-port 100 Gigabit Ethernet Interface Module (1X100GE)	
2-port 100 Gigabit Ethernet Interface Module (2X100 GE)	
2-port 40 Gigabit Ethernet Interface Module (2X40GE)	
1-port OC48 ⁶ / STM-16 or 4-port OC-12/OC-3 / STM-1/STM-4 + 12-port T1/E1 + 4-Port T3/E3 CEM Interface Module	
8/16-port 1 Gigabit Ethernet (SFP/SFP) + 1-port 10 Gigabit Ethernet (SFP+) / 2-port 1 Gigabit Ethernet (CSFP) Interface Module	
48-port T1/E1 Interface Module	No support
48-port T3/E3 Interface Module	No support
1-port OC-192 Interface Module + 8-port Low Rate Interface Module	No support

⁶ Any of the 4 ports can be used as an OC48, but if a port is configured as OC48, then the remaining 3 ports are disabled.

Installing the Power Supply

The Cisco NCS 4206 provides the choice of two different power supplies:

- DC power
 - 900 W DC power: –40VDC to –72VDC

The DC power supply provides option to connect with two different sources (dual feed); positive (+) and negative (-) are marked on the PSU terminals.

Each power supply provides a dual primary input power connection.



Caution The power supply must be wired before plugging the power supply in the chassis. Ensure the branch circuit breaker is turned off. Only after installing the power supply in the chassis, should the branch circuit breaker be turned on. The branch circuit breaker must be turned off before unplugging the power supply. Read the installation instructions before connecting the system to the power source. Statement 10



Caution Do not use interface module and power supply ejector handles to lift the chassis; using the handles to lift the chassis can deform or damage the handles.

Preventing Power Loss

Use the following guidelines to prevent power loss to the chassis.

- To prevent loss of input power, ensure that the total maximum load on each circuit supplying the power supplies is within the current ratings of the wiring and breakers.
- In some systems, you can use an UPS to protect against power failures at your site. Avoid UPS types that use ferroresonant technology. These UPS types can become unstable with systems like the Cisco NCS 4206, which can have substantial current draw fluctuations due to bursty data traffic patterns.

Use the information in the [DC Power Specifications](#) section to estimate the power requirements and heat dissipation of a Cisco NCS 4206 based on a given configuration. Determining power requirements is useful for planning the power distribution system.

Power Connection Guidelines

This section provides guidelines for connecting the Cisco NCS 4206 power supplies to the site power source.

**Warning**

Never defeat the ground conductor or operate the equipment in the absence of a suitably installed ground conductor. Contact the appropriate electrical inspection authority or an electrician if you are uncertain that suitable grounding is available. Statement 213

**Warning**

The plug-socket combination must be accessible at all times because it serves as the main disconnecting device. Statement 1019

**Warning**

This product requires short-circuit (overcurrent) protection, to be provided as part of the building installation. Install only in accordance with national and local wiring regulations. Statement 1045

Guidelines for DC-Powered Systems

Basic guidelines for DC-powered systems include the following:

- Each chassis power supply should have its own dedicated input power source. The source must comply with the safety extra-low voltage (SELV) requirements in the UL 60950, CSA 60950, EN 60950, and IEC 60950 standards.
- The circuit must be protected by a dedicated two-pole circuit breaker. The circuit breaker should be sized according to the power supply input rating and local or national code requirements.
- The circuit breaker is considered the disconnect device and should be easily accessible.
- The system ground is the power supply and chassis ground.
- Do not connect the DC return wire to the system frame or to the system grounding equipment.
- Use the grounding lug to attach a wrist strap for ESD protection during servicing.

Installing the DC Power Supply



Note This equipment is suitable for installation in Network Telecommunications Facilities and locations where the NEC applies.



Note This equipment is suitable for installations utilizing the Common Bonding Network (CBN).



Note The grounding architecture of this product is DC-Isolated (DC-I) for DC-powered products. DC-powered products have a nominal operating DC voltage of 48 VDC.

Installing the DC Power Supply Module

Perform the following procedure to install the power supply module:

Procedure

-
- Step 1** Ensure that the system (earth) ground connection has been made. For ground connection installation instructions, see the [Installing the Chassis Ground Connection](#).
 - Step 2** If necessary, remove the blank power supply filler plate from the chassis power supply bay opening by loosening the captive installation screws.
 - Step 3** Verify that power to the DC circuit connected to the power supply you are installing is off. To ensure that power has been removed from the DC circuits, locate the circuit breakers for the DC circuits, switch the circuit breakers to the OFF position, and tape the circuit-breaker switches in the OFF position.
 - Step 4** Grasp the power supply handle with one hand. Place your other hand underneath the power supply, as shown in the figure below. Slide the power supply into the power supply bay. Make sure that the power supply is fully seated in the bay.

Figure 59: Installing the DC Power Supply

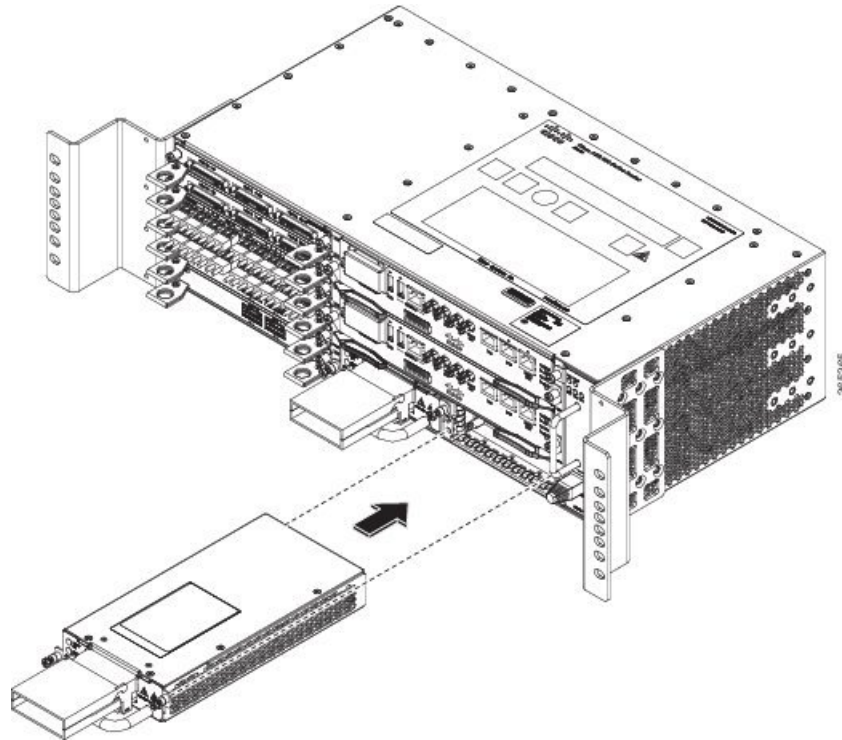

- Step 5** Tighten the captive installation screws of the power supply. The recommended maximum torque is 25 in.-lb (2.82 N-m). If you are installing a redundant DC power supply, repeat these steps for the second power source.

Connecting DC Power Supply Unit (A900-PWR900-D2)

A900-PWR900-D2 is a dual feed 900W DC PSU. The DC power supply accepts a dual-hole type lug. The lug must be a UL listed, CSA certified and rated to accept the 8 AWG cable. The lug is assembled on the unit with two nuts.



Warning Before performing any of the following procedures, ensure that power is removed from the DC circuit.

Tools and Equipment

- Dual-hole lugs
- Double barrel with inspection hole
- Hole spacing is 5/8 in.
- Lug tab width max 0.46 in.
- Nuts
- PSU can accommodate 10 – 6 AWG

- Number 2 Phillips Screwdriver
- 7 mm nut driver or 7 mm socket on a torque wrench

Procedure

- Step 1** Locate the terminal block on the power supply unit.
- Step 2** Flap open the front protective cover on the power supply unit.
- Step 3** Use a wire-stripping tool to strip the ends of each of the two wires coming from the DC-input power source as recommended by the lug manufacturer.
- Note** Stripping more than the recommended amount of wire can leave behind exposed wire from the terminal block after installation.
- Step 4** Identify the positive and negative feed positions for the terminal block. The recommended wiring sequence is as in the figure below.
- Step 5** Attach the lugs on the terminal block, see the figure below.

Figure 60: Power Supply with Lead Wires

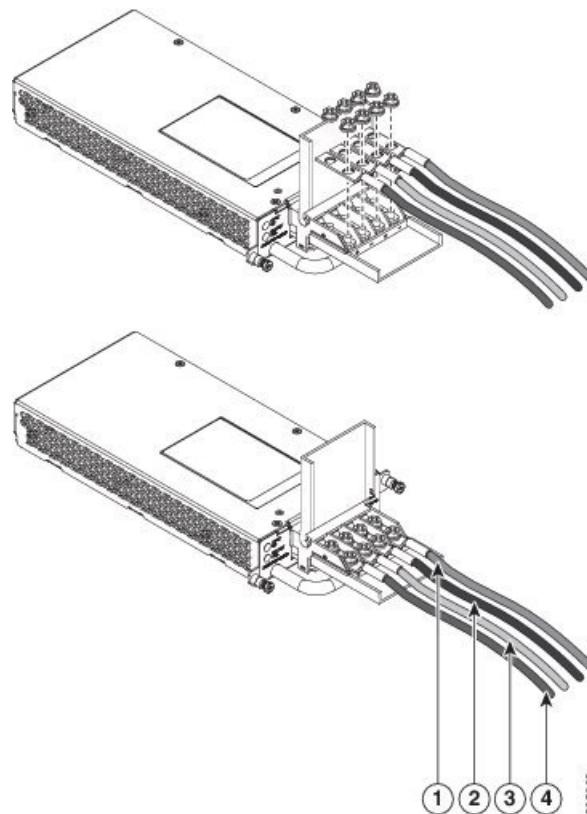

1, 3	Negative (-) lead wire	2, 4	Positive (+) lead wire
---------	------------------------	---------	------------------------

Caution Do not overtorque the fasteners of the terminal block. The recommended maximum torque is from 25 in.-lb (2.82 N-m).

Step 6 Use a tie wrap to secure the wires to the rack, so that the wires are not pulled from the terminal block by casual contact. Make sure the tie wrap allows for some slack in the wire.

Activating the DC Power Supply

Perform the following procedure to activate the DC power supply:

Procedure

Step 1 Remove the tape from the circuit-breaker switch handle, and restore power by moving the circuit-breaker switch handle to the On (I) position.

Step 2 Verify power supply operation by checking if the power supply front panel LEDs are in the following states:

- INPUT OK LED is green
- OUTPUT FAIL LED is green

If the LEDs indicate a power problem, see [Troubleshooting](#).

If you are installing a redundant DC power supply, ensure that each power supply is connected to a separate power source in order to prevent power loss in the event of a power failure.

If you are installing a redundant DC power supply, repeat these steps for the second power source.

Removing and Replacing the DC Power Supply

This section provides information about removing and replacing the DC power supply in the Cisco NCS 4206.



Note The Cisco NCS 4206 power supplies are hot-swappable. If you have installed redundant power supply modules, you can replace a single power supply without interrupting power to the router.



Caution To avoid erroneous failure messages, allow at least 2 minutes for the system to reinitialize after a power supply has been removed or replaced.

Procedure

Step 1 Verify the circuit breaker connected to the power supply that has to be replaced.

- Step 2** Before servicing the power supply, switch off the circuit breaker in your equipment area. As an additional precaution, tape the circuit-breaker switch in the Off position.
- Step 3** Slip on the ESD-preventive wrist strap that was included in the accessory kit.
- Note** The power supplies are not fed by both power units. Shutting off the incorrect power supply may cause a traffic outage.
- Step 4** Measure the DC voltage on the failed power supply input, thus ensuring that the correct unit has been powered off.
- Step 5** Loosen the captive screws on the DC power supply.
- Step 6** Grasping the power supply handle with one hand, pull the power supply out from the chassis while supporting it with the other hand.
- Step 7** Remove the lugs from the PSU.
- Step 8** Replace the new DC PSU and connect the DC leads to the power supply as before
- Step 9** Turn on the circuit breaker or the reinstall the fuse.
- Step 10** Verify the power supply by checking if the front panel LEDs are as below:
- Input OK LED is green
 - Output FAIL LED is green
- Note** Replace the DC power supply within 5 minutes. If the power supply bay is to remain empty, install a blank filler plate (Cisco part number A900-PWR-BLANK) over the opening, and secure it with the captive installation screws.

Installing the AC power Supply



Warning This product requires short-circuit (over current) protection, to be provided as part of the building installation. Install only in accordance with national and local wiring regulations.

Installing the AC Power Supply Module for A900-PWR550-A (550 W) and A900-PWR1200-A (1200 W)

Follow these steps to install the power supply module:

Procedure

- Step 1** Ensure that the system (earth) ground connection has been made. For ground connection installation instructions, see the [Installing the Chassis Ground Connection](#).
- Step 2** If necessary, remove the blank power supply filler plate from the chassis power supply bay opening by loosening the captive installation screws.
- Step 3** Grasp the power supply handle with one hand. Place your other hand underneath the power supply, as shown in the figure below. Slide the power supply into the power supply bay. Make sure that the power supply is fully seated in the bay.

Figure 61: Installing the A900-PWR550-A AC Power Supply

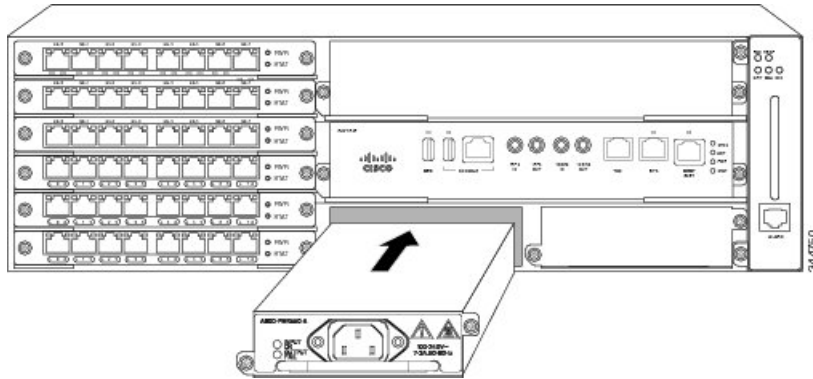
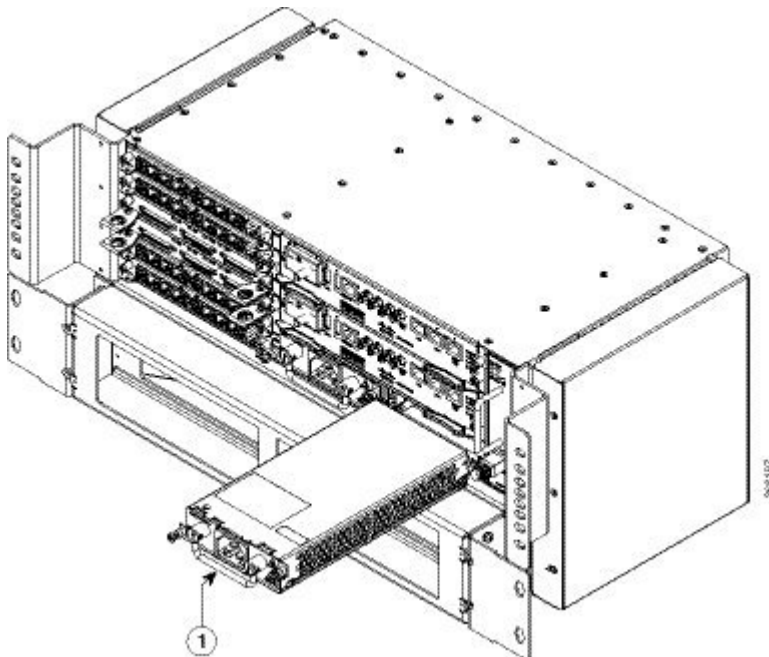

Figure 62: Installing the A900-PWR1200-A AC Power Supply



1	AC Power Supply
---	-----------------

Step 4 Tighten the captive installation screws of the power supply. The recommended maximum torque is 25 in.-lb (2.82 N-m).

Warning Power supply captive installation screws must be tight to ensure protective grounding continuity.

Recommended Power Cables

We recommend the following power cables for Cisco NCS 4206 routers:

Table 12: Power Cable PIDs for A900-PWR550-A (550 W)

PID	Description
CAB-AC	AC POWER CORD, UNITED STATES, 125V, 10A, 2.5m, C13,NEMA, 5-15P
CAB-AC-RA	AC POWER CORD, UNITED STATES, 125V, 10A, 2.5m, RA-C13, NEMA, 5-15P
CAB-ACA	AC Power Cord (Australia), C13, AS 3112, 2.5m
CAB-ACA-RA	AC Power Cord, Australian, 10A, Right Angle
CAB-ACC	AC Power Cord (China), C13, GB15934, CCC, 2.5m
CAB-ACC-RA	AC Power Cord China, Right Angle
CAB-ACE	AC Power Cord (Europe), C13, CEE 7, 1.5M
CAB-ACE-RA	AC Power Cord Europe, Right Angle
CAB-ACI	AC Power Cord (Italy), C13, CEI 23-16, 2.5m
CAB-ACI-RA	AC Power Cord, Italian, Right Angle
CAB-ACR	AC Power Cord (Argentina), C13, EL 219 (IRAM 2073), 2.5m
CAB-ACR-RA	AC POWER CORD ARGENTINA, Right Angle
CAB-ACS	AC Power Cord (Switzerland), C13, IEC 60884-1, 2.5m
CAB-ACS-RA	AC Power Cord, Switzerland, Right Angle
CAB-ACU	AC Power Cord (UK), C13, BS 1363, 2.5m
CAB-ACU-RA	AC Power Cord UK, Right Angle
CAB-IND	AC Power Cord (India), C13
CAB-IND-RA	AC Power Cord (India), RA-C13
CAB-JPN	AC Power Cord (Japan), C13, JIS C 8303, 2.5m
CAB-JPN-RA	AC Power Cord (Japan), RA-C13, JIS C 8303, 2.5m

Table 13: Power Cable PIDs for A900-PWR1200-A (1200 W)

PID	Description
PWR-CAB-AC-USA520	US AC Power Cord for Cisco ASR 900, NEMA 5-20
PWR-CAB-AC-USA	Power Cord for AC V2 Power Module (USA), NEMA L6-20P
PWR-CAB-AC-AUS	Power Cord for AC V2 Power Module (Australia), AS 3112

PID	Description
PWR-CAB-AC-EU	Power Cord for AC V2 Power Module (Europe), CEE 7/7
PWR-CAB-AC-ITA	Power Cord for AC V2 Power Module (Italy), CEI-23-50
PWR-CAB-AC-SA	Power Cord for AC V2 Power Module (South Africa), SABS 164
PWR-CAB-AC-UK	Power Cord for AC V2 Power Module (UK), EN 60309-2
PWR-CAB-AC-ISRL	Power Cord for AC V2 Power Module (Israel), SI 32
PWR-CAB-AC-CHN	Power Cord for AC V2 Power Module (China), GB2099.1/GB1002
PWR-CAB-AC-BRA	Power Cord for AC V2 Power Module (Brazil), NBR 14136
PWR-CAB-AC-SUI	Power Cord for AC V2 Power Module (Swiss), SEV 1011
PWR-CAB-AC-JPN	Power Cord for AC V2 Power Module (Japan), JIS C8303
PWR-CAB-AC-IND	India AC Power Cord for Cisco ASR 900, IS:1293
PWR-CAB-AC-ARG	AC POWER CORD, WIRE HARNESS, Argentina, IRAM 2073, IEC60320 C21, ST, 4M, 30 AWG, STRANDED, 250.0 V, 16.0 A

Activating the AC Power Supply

Follow these steps to activate the AC power supply:

Procedure

Step 1 Plug the power cord into the power supply.

Step 2 Connect the other end of the power cord to an AC-input power source.

Step 3 Verify power supply operation by checking that the power supply LEDs are in the following states:

- INPUT OK LED is green
- OUTPUT FAIL LED is green

Step 4 If the LEDs indicate a power problem, see the Troubleshooting section for more information.

Step 5 If you are installing a redundant power supply, repeat these steps for the second power source.

Note If you are installing a redundant AC power supply, ensure that each power supply is connected to a separate power source in order to prevent power loss in the event of a power failure.

Power Cable Bracket (A9XX-PWR-CBL-MGMT)

To install the optional cable management bracket, perform these steps:

Procedure

- Step 1** Attach the power cable bracket (A9XX-PWR-CBL-MGMT) to the rack with its preassembled captive screws. The recommended maximum torque is 10 in.-lb (1.12 N-m).

Figure 63: Cable Management Bracket (A9XX-PWR-CBL-MGMT)

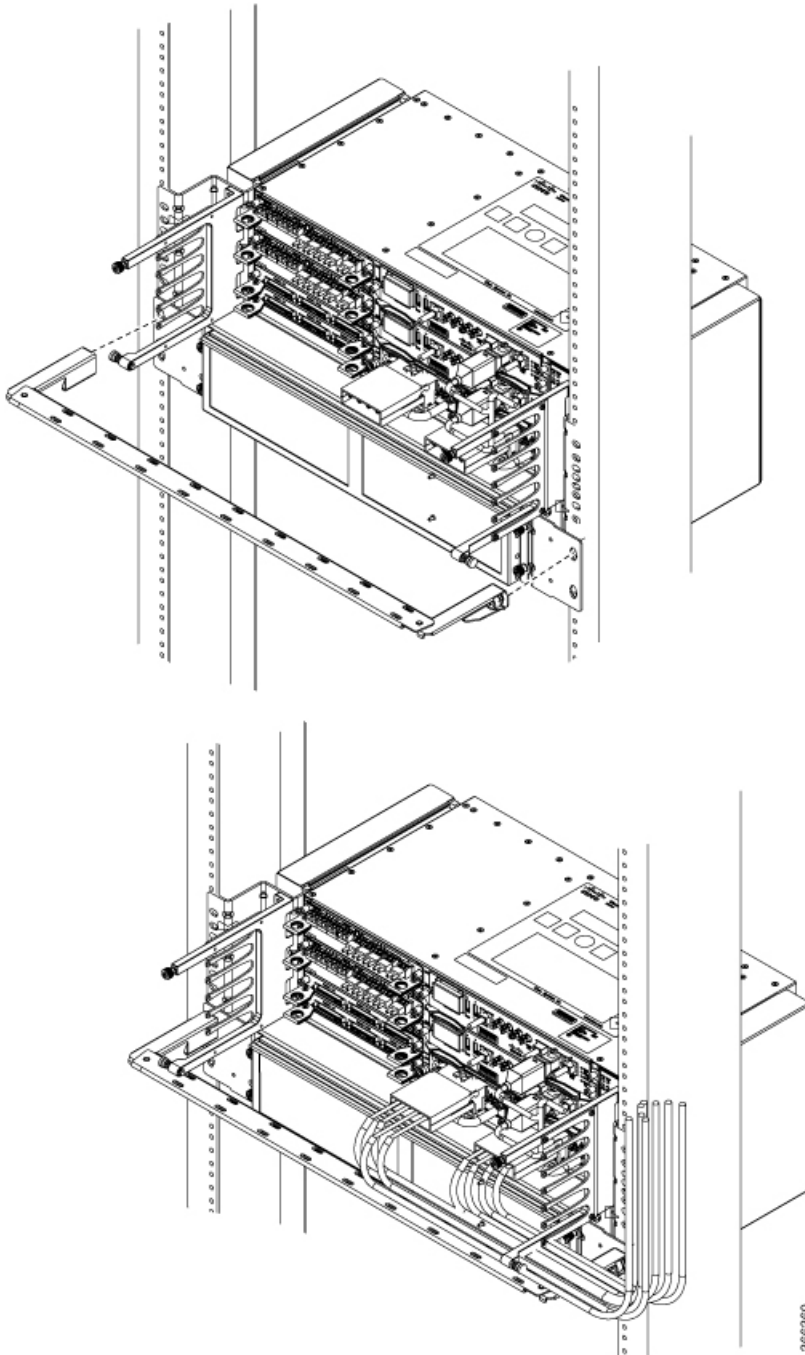

Step 2 Route the cables as show in the figure.

Top Cable Management Bracket (A9XX-TOP-CBL-MGMT)

To install the optional top cable management bracket, perform these steps:

Procedure

Step 1 Connect the grounding lugs using a crimping tool (as specified by the ground lug manufacturer), crimp the ground lug to the ground wire.

Figure 64: Cable Management Bracket - Rear

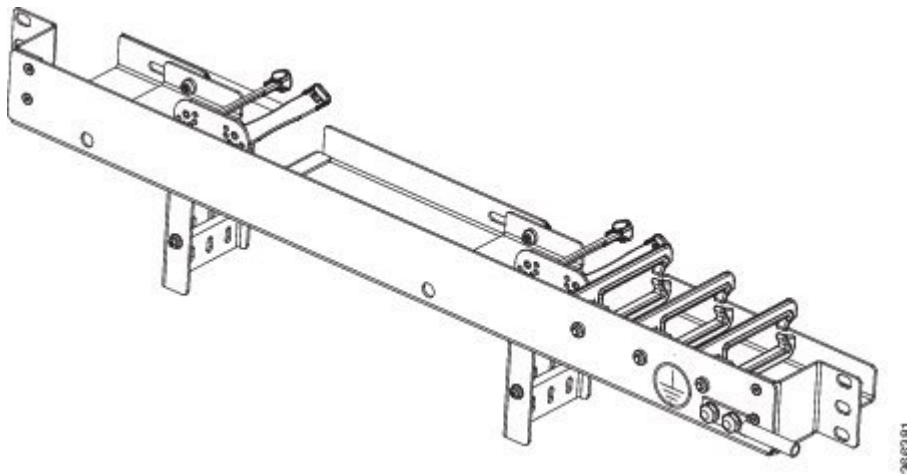

Step 2 Connect the other end of the ground wire to a suitable grounding point at your site.

Step 3 Position the cable management brackets against the front of the rack and align the four screw holes, as shown in the figure below.

Figure 65: Cable Management Bracket - Front

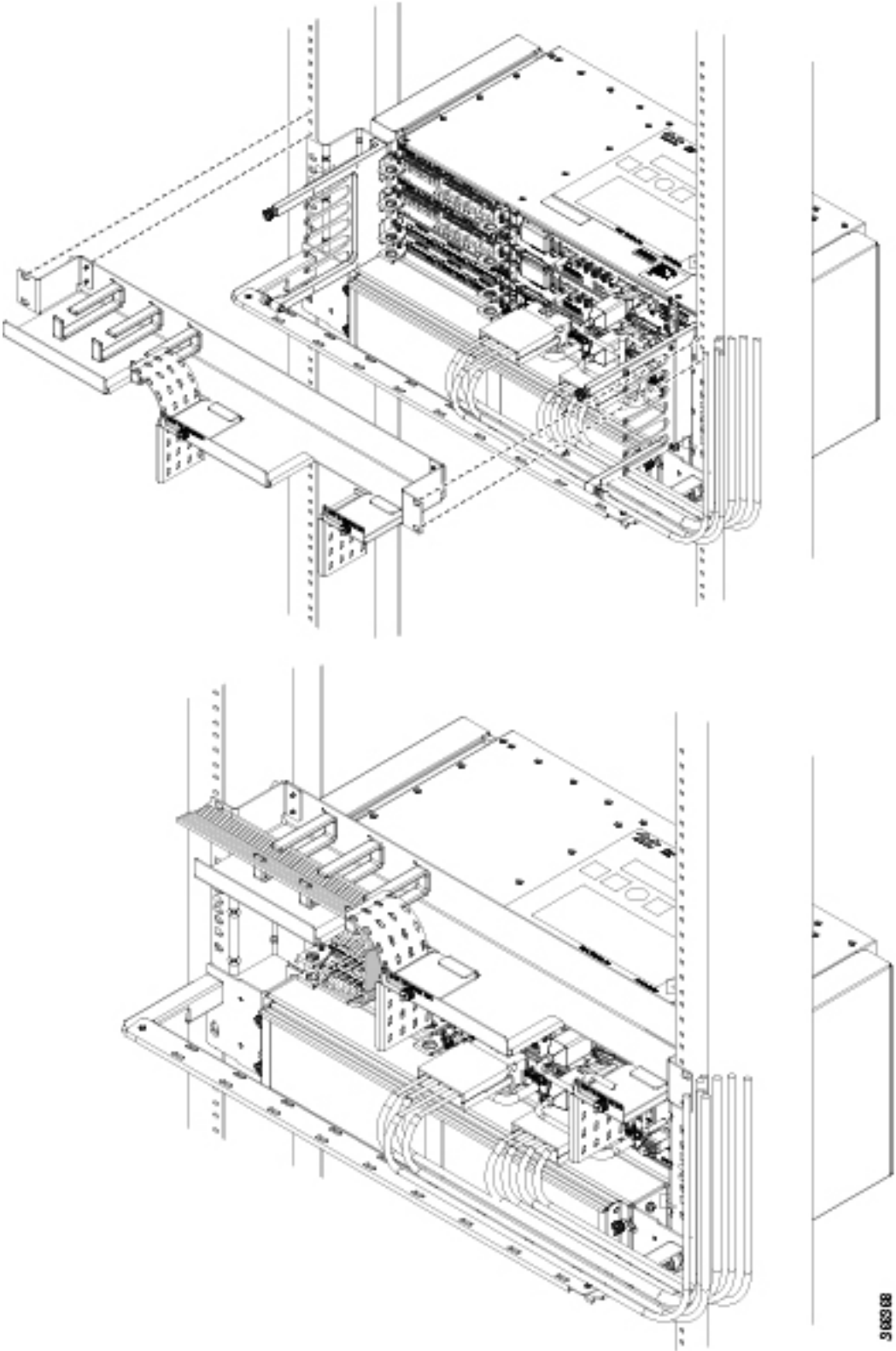

- Step 4** Secure the cable management brackets with four rack mount screws with a minimum of 5 mm gap with the top of the chassis. The recommended maximum torque is 10 in.-lb (1.12 N-m).
- Step 5** Route the cables as show in the figure. Ensure that proper slack is provided for the sliders in the brackets to move easily.
-

Connecting the Cisco NCS 4206 to the Network



Note When installing the cabling to the RSPs, we recommend that you leave a service loop of extra cabling sufficient to allow for fan tray removal.

Connecting Console Cables



Note You cannot use the USB and RS232 console ports at the same time; if you insert the USB cable into the chassis, the RS232 port is disabled.

Connecting to the Serial Port using Microsoft Windows

This procedure shows how to connect to the serial port using Microsoft Windows.



Note Install the USB device driver before establishing a physical connection between the chassis and the PC, by using the USB Console cable plugged into the USB serial port. Otherwise, the connection will fail. For more information, see [Installing the Cisco Microsoft Windows USB Device Driver](#).

Procedure

Step 1 Connect the end of the console cable with the RJ45 connector to the light blue console port on the chassis. or Connect a USB Type A-to-Type A cable to the USB console port as shown in the figure below . If you are using the USB serial port for the first time on a Windows-based PC, install the USB driver now according to the instructions in the following sections:

- [Installing the Cisco Microsoft Windows XP USB Driver, on page 90](#)
- [Installing the Cisco Microsoft Windows 2000 USB Driver, on page 90](#)
- [Installing the Cisco Microsoft Windows Vista USB Driver, on page 90](#)

Note You cannot use the USB port and the EIA port concurrently. See [Connecting to the Auxiliary Port](#). When the USB port is used it takes priority over the RJ45 EIA port.

Note The USB Type A-to-Type A cable is not included with the Cisco NCS 4206; it is ordered separately.

Step 2 Connect the end of the cable with the DB-9 connector (or USB Type-A) to the terminal or PC. If your terminal or PC has a console port that does not accommodate a DB-9 connector, you must provide an appropriate adapter for that port.

Step 3 To communicate with the chassis, start a terminal emulator application, such as Microsoft Windows HyperTerminal. This software should be configured with the following parameters:

- 9600 baud
- 8 data bits
- no parity
- 1 stop-bit
- no flow control

Figure 66: Connecting the USB Console Cable to the Cisco NCS 4206

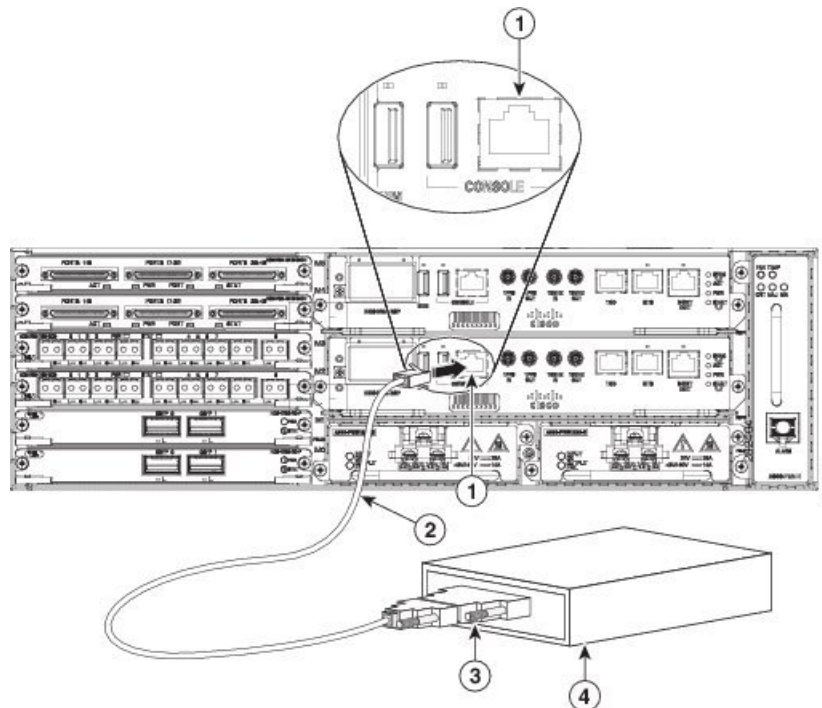

1	USB Type-A console port	2	USB 5-pin mini USB Type-B to USB Type-A console cable
3	USB Type-A	—	—

Connecting to the Console Port using Mac OS X

This procedure describes how to connect a Mac OS X system USB port to the console using the built in OS X Terminal utility.

Procedure

Step 1 Use the Finder to go to Applications > Utilities > Terminal.

Step 2 Connect the OS X USB port to the .

Step 3 Enter the following commands to find the OS X USB port number:

Example:

```
macbook:user$ cd /dev
macbook:user$ ls -ltr /dev/*usb*
crw-rw-rw- 1 root  wheel          9,  66 Apr  1 16:46 tty.usbmodem1a21 DT-macbook:dev user$
```

Step 4 Connect to the USB port with the following command followed by the chassis USB port speed

Example:

```
macbook:user$ screen /dev/tty.usbmodem1a21 9600
```

To disconnect the OS X USB console from the Terminal window

Enter Ctrl-a followed by Ctrl-\

Connecting to the Console Port using Linux

This procedure shows how to connect a Linux system USB port to the console using the built in Linux Terminal utility.

Procedure

Step 1 Open the Linux Terminal window.

Step 2 Connect the Linux USB port to the chassis.

Step 3 Enter the following commands to find the Linux USB port number:

Example:

```
root@usb-suse# cd /dev
root@usb-suse /dev# ls -ltr *ACM*
crw-r--r-- 1 root  root    188,  0 Jan 14 18:02 ttyACM0
root@usb-suse /dev#
```

Step 4 Connect to the USB port with the following command followed by the chassis USB port speed:

Example:

```
root@usb-suse /dev# screen /dev/ttyACM0 9600
```

To disconnect the Linux USB console from the Terminal window

Enter Ctrl-a followed by : then quit.

Installing the Cisco Microsoft Windows USB Device Driver

A USB device driver must be installed the first time a Microsoft Windows-based PC is connected to the USB serial port on the chassis.

Installing the Cisco Microsoft Windows XP USB Driver

This procedure shows how to install the Microsoft Windows XP USB driver. Download the driver for your chassis model from the Tools and Resources Download Software site, USB Console Software category, at the following URL:

<https://www.cisco.com/c/en/us/support/index.html>

Procedure

- Step 1** Unzip the file Cisco_usbconsole_driver_X_X.zip (where X is a revision number).
 - Step 2** If using 32-bit Windows XP double-click the file setup.exe from the Windows_32 folder, or if using 64-bit Windows XP double-click the file setup(x64).exe from the Windows_64 folder.
 - Step 3** The Cisco Virtual Com InstallShield Wizard begins. Click Next.
 - Step 4** The Ready to Install the Program window appears, Click Install.
 - Step 5** The InstallShield Wizard Completed window appears. Click Finish.
 - Step 6** Connect the USB cable to the PC and chassis USB console ports. The EN LED for the USB console port turns green, and within a few moments the Found New Hardware Wizard appears. Following the instructions to complete the installation of the driver.
 - Step 7** The USB console is ready for use.
-

Installing the Cisco Microsoft Windows 2000 USB Driver

This procedure shows how to install the Microsoft Windows 2000 USB driver.

Procedure

- Step 1** Obtain the file Cisco_usbconsole_driver.zip from the Cisco.com web site and unzip it.
 - Step 2** Double-click the file setup.exe.
 - Step 3** The Cisco Virtual Com InstallShield Wizard begins. Click **Next**.
 - Step 4** The Ready to Install the Program window appears, Click **Install**.
 - Step 5** The InstallShield Wizard Completed window appears. Click **Finish**.
 - Step 6** Connect the USB cable to the PC and chassis USB console ports. The EN LED for the USB console port turns green, and within a few moments a series of Found New Hardware Wizard windows appear. Following the instructions to complete the installation of the driver.

The USB console is ready for use.
-

Installing the Cisco Microsoft Windows Vista USB Driver

This procedure shows how to install the Microsoft Windows Vista USB driver.

Procedure

-
- Step 1** Obtain the file Cisco_usbconsole_driver.zip from the Cisco.com web site and unzip it.
- Step 2** If using 32-bit Windows Vista double-click the file setup.exe from the Windows_32 folder, or if using 64-bit Windows Vista double-click the file setup(x64).exe from the Windows_64 folder.
- Step 3** The Cisco Virtual Com InstallShield Wizard begins. Click **Next**.
- Step 4** The Ready to Install the Program window appears, Click **Install**.
- Note** If a User Account Control warning appears, click “**Allow - I trust this program...**” to proceed.
- Step 5** The InstallShield Wizard Completed window appears. Click **Finish**.
- Step 6** Connect the USB cable to the PC and chassis USB console ports. The EN LED for the USB console port turns green, and within a few moments a pop up window stating “Installing device driver software” appears. Following the instructions to complete the installation of the driver.
- The USB console is ready for use.
-

Uninstalling the Cisco Microsoft Windows USB Driver

This section provides instructions for how to uninstall the Cisco Microsoft Windows USB device driver.

Uninstalling the Cisco Microsoft Windows XP and 2000 USB Driver Using the Add Remove Programs Utility



Note Disconnect the chassis console terminal before uninstalling the driver.

Procedure

-
- Step 1** Click **Start > Control Panel > Add or Remove Programs**.
- Step 2** Scroll to Cisco Virtual Com and click **Remove**.
- Step 3** When the Program Maintenance window appears, select the **Remove** radio button. Click **Next**.
-

Uninstalling the Cisco Microsoft Windows XP and 2000 USB Driver Using the Setup.exe Program



Note Disconnect the chassis console terminal before uninstalling the driver.

Procedure

-
- Step 1** Run the setup.exe for Windows 32-bit or setup(x64).exe for Windows-64bit. Click **Next**.
 - Step 2** The InstallShield Wizard for Cisco Virtual Com appears. Click **Next**.
 - Step 3** When the Program Maintenance window appears, select the **Remove** radio button. Click **Next**.
 - Step 4** When the Remove the Program window appears, click **Remove**.
 - Step 5** When the InstallShield Wizard Completed window appears click **Finish**.
-

Uninstalling the Cisco Microsoft Windows Vista USB Driver

This procedure shows you how to uninstall the Microsoft Windows Vista USB driver.



Note Disconnect the chassis console terminal before uninstalling the driver.

Procedure

-
- Step 1** Run the setup.exe for Windows 32-bit or setup(x64).exe for Windows-64bit. Click **Next**.
 - Step 2** The InstallShield Wizard for Cisco Virtual Com appears. Click **Next**.
 - Step 3** When the Program Maintenance window appears, select the **Remove** radio button. Click **Next**.
 - Step 4** When the Remove the Program window appears, click **Remove**.
- Note** If a User Account Control warning appears, click “**Allow - I trust this program...**” to proceed.
- Step 5** When the InstallShield Wizard Completed window appears click **Finish**.
-

Connecting to the Auxiliary Port

When a modem is connected to the auxiliary port, a remote user can dial in to the chassis and configure it. Use a light blue console cable and the DB-9-to-DB-25 connector adapter.



Note The console cable and DB-9-to-DB-25 connector are not included with the Cisco NCS 4206; they are ordered separately.

To connect a modem to the chassis, follow these steps:

Procedure

Step 1 Connect the RJ45 end of the adapter cable to the black AUX port on the chassis, as shown in the figure below.

Figure 67: Connecting a Modem to the Cisco NCS 4206

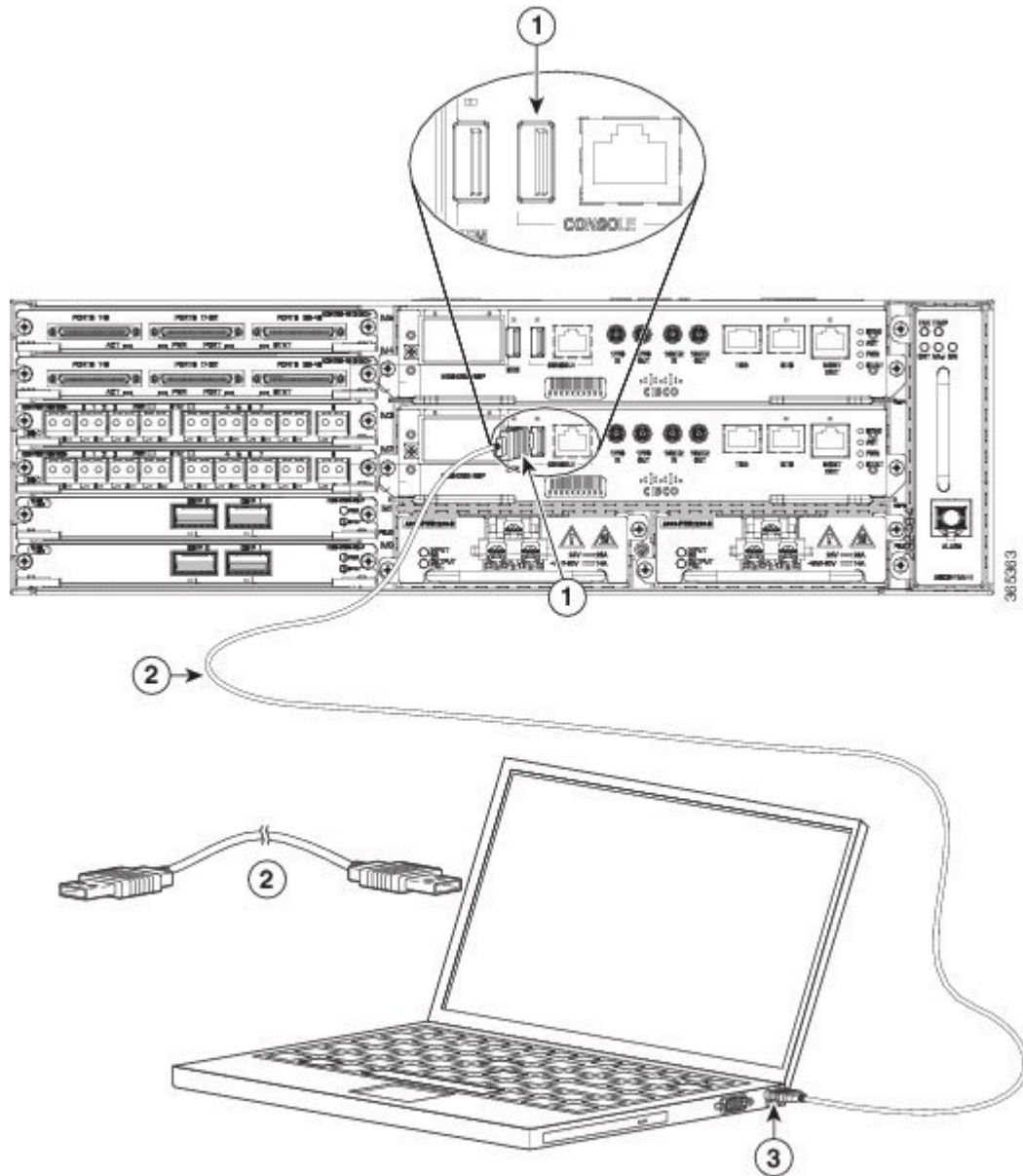

Step 2 Connect the DB-9 end of the console cable to the DB-9 end of the modem adapter.

- Step 3** Connect the DB-25 end of the modem adapter to the modem.
- Step 4** Make sure that your modem and the chassis auxiliary port are configured for the same transmission speed (up to 115200 bps is supported) and for mode control with data carrier detect (DCD) and data terminal ready (DTR) operations.

Connecting a Management Ethernet Cable

When using the Ethernet Management port in the default mode (speed-auto and duplex-auto) the port operates in auto-MDI/MDI-X mode. The port automatically provides the correct signal connectivity through the Auto-MDI/MDI-X feature. The port automatically senses a crossover or straight-through cable and adapts to it.

However, when the Ethernet Management port is configured to a fixed speed (10 or 100 Mbps) through command-line interface (CLI) commands, the port is forced to MDI mode.

When in a fixed-speed configuration and MDI mode:

- Use a crossover cable to connect to an MDI port
- Use a straight-through cable to connect to an MDI-X port



Warning

To comply with the Telcordia GR-1089 NEBS standard for electromagnetic compatibility and safety, connect the Management Ethernet ports only to intra-building or unexposed wiring or cable. The intrabuilding cable must be shielded and the shield must be grounded at both ends. The intra-building port(s) of the equipment or subassembly must not be metallicly connected to interfaces that connect to the OSP or its wiring. These interfaces are designed for use as intra-building interfaces only (Type 2 or Type 4 ports as described in GR-1089-CORE) and require isolation from the exposed OSP cabling. The addition of Primary Protectors is not sufficient protection in order to connect these interfaces metallicly to OSP wiring.

Installing and Removing SFP Modules

The Cisco NCS 4206 supports a variety of SFP modules, including optical and Ethernet modules. For information on how to install and remove SFP modules, see the documentation for the SFP module at http://www.cisco.com/en/US/partner/products/hw/modules/ps5455/prod_installation_guides_list.html.

For information about inspecting and cleaning fiber-optic connections, see http://www.cisco.com/en/US/partner/tech/tk482/tk876/technologies_white_paper09186a0080254eba.shtml.



Caution

We recommend that you wait 30 seconds between removal and insertion of an SFP on an interface module. This time is recommended to allow the transceiver software to initialize and synchronize with the standby RSP. Changing an SFP more quickly could result in transceiver initialization issues that disable the SFP.

Connecting a USB Flash Device

To connect a USB flash device to the Cisco NCS 4206, insert the memory stick in the USB port labeled MEM. The Flash memory module can be inserted in only one way, and can be inserted or removed regardless of whether the is powered up or not.

The figure below shows the USB port connector on the Cisco NCS 4206.

Figure 68: Cisco NCS 4206 Flash Token Memory Stick

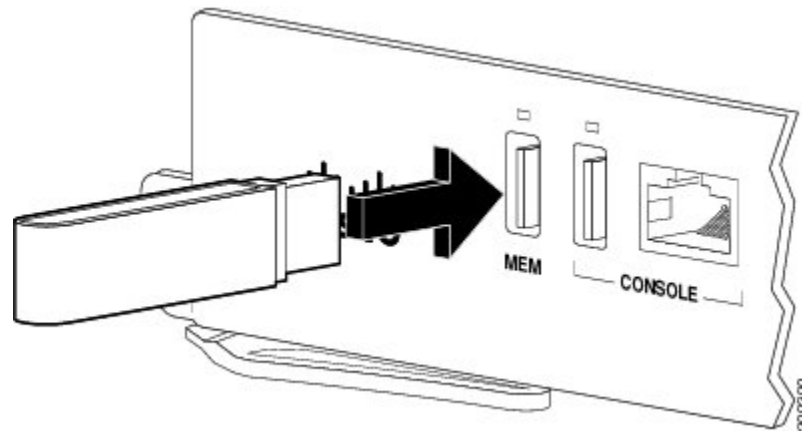

Removing a USB Flash Device

To remove and then replace a USB flash token memory stick from a Cisco NCS 4206, follow these steps:

Procedure

Step 1 Pull the memory stick from the USB port.

Step 2 To replace a Cisco USB Flash memory stick, simply insert the module into the USB port labeled MEM. The Flash memory module can be inserted in only one way, and can be inserted or removed regardless of whether the is powered up or not.

Note You can insert or remove the memory stick whether the is powered on or not.

Connecting Timing Cables



Note When installing the cabling to the RSPs, we recommend that you leave a service loop of extra cabling sufficient to allow for fan tray removal.

Connecting Cables to the BITS Port using the Wire Wrap Interface

The following steps describe how to connect cables to the BITS port using Wire wrap interface:

Procedure

	Command or Action	Purpose
Step 1	Connect the BITS port using a wire wrap adapter.	

	Command or Action	Purpose
Step 2	Connect the wire wrap adapter to the RJ-45 port.	<p>For information about the Wire wrap pinouts, see Troubleshooting.</p> <p>Warning To comply with the Telcordia GR-1089 NEBS standard for electromagnetic compatibility and safety, connect the BITS ports only to intra-building or unexposed wiring or cable. The intrabuilding cable must be shielded and the shield must be grounded at both ends. The intra-building port(s) of the equipment or subassembly must not be metallicly connected to interfaces that connect to the OSP or its wiring. These interfaces are designed for use as intra-building interfaces only (Type 2 or Type 4 ports as described in GR-1089-CORE) and require isolation from the exposed OSP cabling. The addition of Primary Protectors is not sufficient protection in order to connect these interfaces metallicly to OSP wiring.</p>

Connecting Cables to a GNSS Interface



Note A Y-cable is required to connect to a primary and backup RSP in order to ensure that the chassis continues to transmit timing signals in the event of a network failure. For a mini-coax connection, this Y-cable can be part number CAB-BNC-7INY (7 inch BNC Y-cable). For an Ethernet connection, this Y-cable can be a RJ45 Cat5 1-to-2 splitter (3 female port RJ45 connector).



Note When installing the cabling to the RSPs, we recommend that you leave a service loop of extra cabling sufficient to allow for fan tray removal.

Connecting Cables to the Input 10Mhz or 1PPS Interface

Procedure

-
- Step 1** Connect one end of a mini-coax Y-cable to the GPS unit.
- Step 2** Connect one end of the split-side Y-cable mini-coax to the 10Mhz or 1PPS port on the primary RSP of the Cisco NCS 4206.
- Step 3** Connect the other end of the split-side Y-cable mini-coax to the 10Mhz or 1PPS port on the backup RSP of the Cisco NCS 4206.
-

Connecting Cables to the Output 10Mhz or 1PPS Interface

Procedure

-
- Step 1** Connect one end of a mini-coax Y-cable to the Slave unit.
- Step 2** Connect one end of the split-side Y-cable mini-coax to the 10Mhz or 1PPS port on the primary RSP of the Cisco NCS 4206.
- Step 3** Connect the other end of the split-side Y-cable mini-coax to the 10Mhz or 1PPS port on the backup RSP of the Cisco NCS 4206.
-

Connecting Cables to the ToD Interface

Procedure

-
- Step 1** Connect one end of a straight-through Ethernet cable to the GPS unit.
- Step 2** Connect one end of the split-side Y-cable Ethernet to the ToD port on the primary RSP of the Cisco NCS 4206.
- Step 3** Connect the other end of the split-side Y-cable Ethernet to the ToD port on the backup RSP of the Cisco NCS 4206.

Note For instructions on how to configure clocking, see the *Cisco NCS 4206 Software Configuration Guide*.

Warning To comply with the Telcordia GR-1089 NEBS standard for electromagnetic compatibility and safety, connect the ToD ports only to intra-building or unexposed wiring or cable. The intrabuilding cable must be shielded and the shield must be grounded at both ends. The intra-building port(s) of the equipment or subassembly must not be metallicly connected to interfaces that connect to the OSP or its wiring. These interfaces are designed for use as intra-building interfaces only (Type 2 or Type 4 ports as described in GR-1089-CORE) and require isolation from the exposed OSP cabling. The addition of Primary Protectors is not sufficient protection in order to connect these interfaces metallicly to OSP wiring.

Note For more information about GPS port pinouts, see [Troubleshooting](#).

Connecting Ethernet Cables

The Cisco NCS 4206 interface modules support RJ45 or SFP Ethernet ports. For instructions on how to connect cables to Ethernet SFP ports, see [Connecting Cables to SFP Modules](#).

The RJ45 port supports standard straight-through and crossover Category 5 unshielded twisted-pair (UTP) cables. Cisco Systems does not supply Category 5 UTP cables; these cables are available commercially.

**Warning**

To comply with the Telcordia GR-1089 NEBS standard for electromagnetic compatibility and safety, connect the Gigabit Ethernet ports only to intra-building or unexposed wiring or cable. The intrabuilding cable must be shielded and the shield must be grounded at both ends. The intra-building port(s) of the equipment or subassembly must not be metalically connected to interfaces that connect to the OSP or its wiring. These interfaces are designed for use as intra-building interfaces only (Type 2 or Type 4 ports as described in GR-1089-CORE) and require isolation from the exposed OSP cabling. The addition of Primary Protectors is not sufficient protection in order to connect these interfaces metalically to OSP wiring.

**Note**

When installing the cabling to the RSPs, we recommend that you leave a service loop of extra cabling sufficient to allow for fan tray removal.

Follow these steps to connect the cable to a copper Gigabit Ethernet port:

Procedure

-
- Step 1** Confirm that the is powered off.
 - Step 2** Connect one end of the cable to the Gigabit Ethernet port on the.
 - Step 3** Connect the other end to the BTS patch or demarcation panel at your site.
-

Connecting Cables to SFP Modules

For information on connecting cables to Cisco optical and Ethernet SFP interfaces, see http://www.cisco.com/en/US/partner/products/hw/modules/ps5455/prod_installation_guides_list.html.

Connecting T1/E1 Cables

The physical layer interface for the Cisco NCS 4206 T1/E1 port is a high-density connector. The high-density connector has thumbscrews which should be screwed into the interface when the cable is installed.

**Note**

Patch panels are required in order to connect the high-density interface connectors to individual T1/E1 lines.

Installing the Cable Connectors

T1/E1 Cable Connectors

Figure 69: T1/E1 Cable Connector

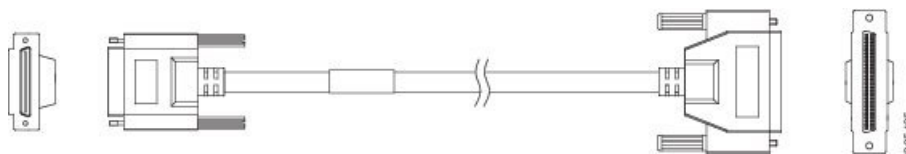

One end of the cable (see the figure above) has a 68-pin connector that plugs into the T1/E1 interface module and the other end of the cable with a 68-pin connector is connected to a RJ48, AMP64 or a DIN patch panel. Use the thumbscrews on either side of the connector to secure the cable to the interface.

For information about the pinout of the cable connecting the T1/E1 interface to the rear of the patch panel, see T1/E1 ports, see the [T1/E1 Port Pinout](#).

Patch Panel Cables

The patch panel cable connects the interface modules with the patch panel.

Each cable connects one VHDCI connector on the interface module to the connector on the patch panel. A set of three cables is required to connect one interface module to one 48-port patch panel.

The following table shows details of the patch panel cables:

Table 14: Patch Panel Cables

Patch Panel Cable	Description
CABLE-16TDM-C	16-port cable for TDM CEM Interface Module, no redundancy, 72 inches in length
CABLE-16TDM-C-L1	16-port cable for TDM CEM Interface Module, no redundancy, 56 inches in length
CABLE-16TDM-C-L2	16-port cable for TDM CEM Interface Module, no redundancy, 63 inches in length
CABLE-16TDM-C-L3	16-port cable for TDM CEM Interface Module, no redundancy, 85 inches in length
CABLE-16TDM-C-L4	16-port cable for TDM CEM Interface Module, no redundancy, 96 inches in length

Connecting Cables to the Patch Panel

Figure 70: Interface Module with the Connector

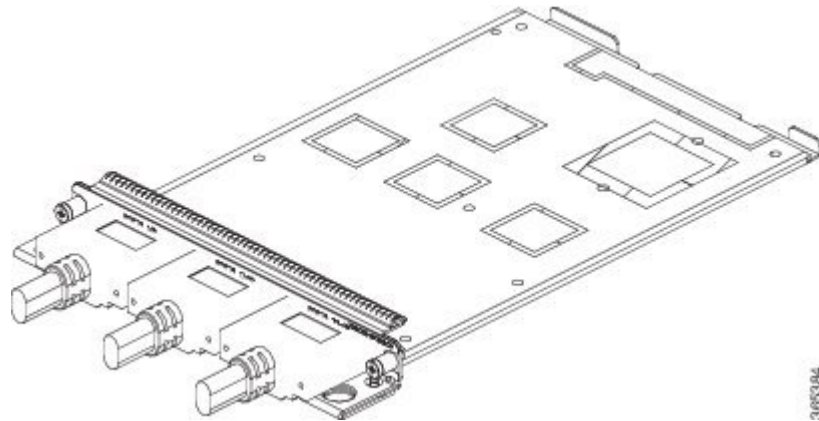
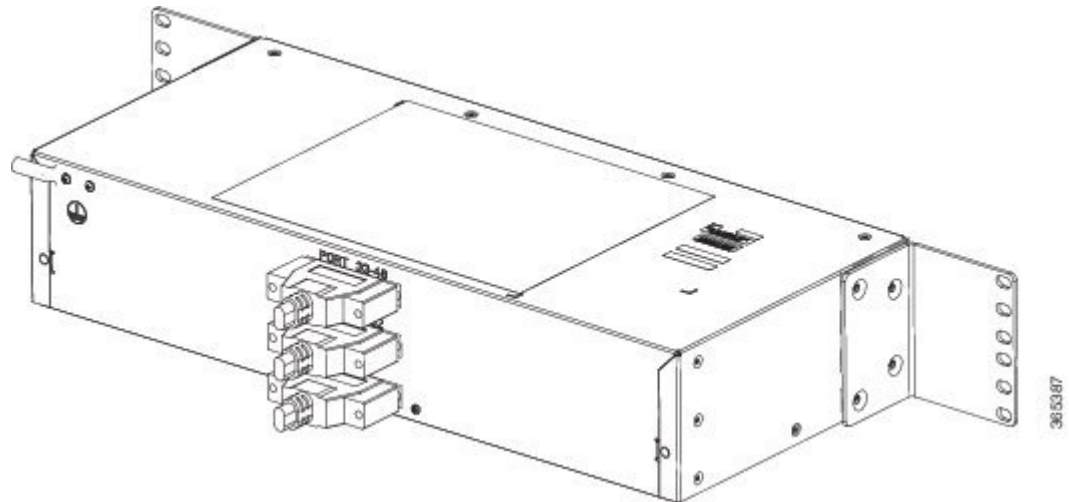

Figure 71: Patch Panel with the Connector



If you are connecting two T1/E1 interfaces to each other, you must cable both interfaces' patch panels together using a T1 straight-through shielded cables. If both T1/E1 interfaces are connected to their patch panels in a different configuration, use a T1 straight-through cable (standard RJ48C patch cable) to connect the patch panels.



Warning

To comply with the Telcordia GR-1089 NEBS standard for electromagnetic compatibility and safety, connect the T1/E1 ports only to intra-building or unexposed wiring or cable. The intrabuilding cable must be shielded and the shield must be grounded at both ends. The intra-building port(s) of the equipment or subassembly must not be metallically connected to interfaces that connect to the OSP or its wiring. These interfaces are designed for use as intra-building interfaces only (Type 1 and Type 3 ports as described in GR-1089-CORE) and require isolation from the exposed OSP cabling. The addition of Primary Protectors is not sufficient protection in order to connect these interfaces metallically to OSP wiring.

Patch Panel Connectors

The PANEL-48-1-DIN and PANEL-48-3-DIN provide 48 DIN 1.0/2.3 connectors on the front side of the patch panel. These connectors terminate to 75 ohm coaxial cable through the DIN plug.

The PANEL-48-1-RJ48 provide 48 RJ45 connector on the front side of the patch panel. These connectors terminate to 110 ohm T1/E1 cable through a RJ45 connector.

Figure 72: Patch Panel Connector on the Patch Panel

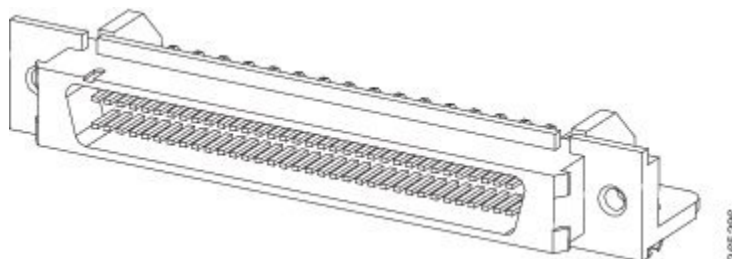
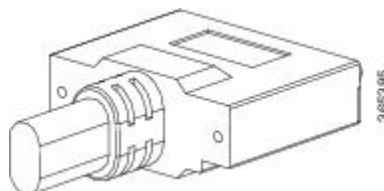

Figure 73: Patch panel Connector on the Interface Module



Patch Panel Cabling for Redundancy

You can connect the patch panels with the interface modules for redundancy, using the Y-cables. The Y-cable stub lengths are reduced, so that the cable does not exceed from the rack spacer. The Y-cables are numbered based on the different stub length. Cable lengths differ for even numbered and odd numbered slots in the chassis.

Table 15: Y-Cable for Redundancy

Bundle PID	Cable Marking	Description
CABLE-16TDM-R1EL1	T1/E1-Cable S-3	16-port cable for TDM CEM Interface Module, 42 inches cable length and 10 inches stub length, even slot
	T1/E1 Cable S-2	16-port cable for TDM CEM Interface Module, 42 inches cable length and 7.5 inches stub length, even slot
	T1/E1 Cable S-1	16-port cable for TDM CEM Interface Module, 42 inches cable length and 6.5 inches stub length, even slot

Bundle PID	Cable Marking	Description
CABLE-16TDM-R1EL2	T3/E3-Cable M-3	16-port cable for TDM CEM Interface Module, 62 inches cable length and 10 inches stub length, even slot
	T3/E3-Cable M-2	16-port cable for TDM CEM Interface Module, 62 inches cable length and 7.5 inches stub length, even slot
	T3/E3-Cable M-1	16-port cable for TDM CEM Interface Module, 62 inches cable length and 6.5 inches stub length, even slot
CABLE-16TDM-R1EL3	T1/E1-Cable L-3	16-port cable for TDM CEM Interface Module, 78 inches cable length and 10 inches stub length, even slot
	T1/E1 Cable L-2	16-port cable for TDM CEM Interface Module, 78 inches cable length and 7.5 inches stub length, even slot
	T1/E1 Cable L-1	16-port cable for TDM CEM Interface Module, 78 inches cable length and 6.5 inches stub length, even slot
CABLE-16TDM-R3EL1	T3/E3-Cable S-3	16-port cable for TDM CEM Interface Module, 42 inches cable length and 10 inches stub length, even slot
	T3/E3-Cable S-2	16-port cable for TDM CEM Interface Module, 42 inches cable length and 7.5 inches stub length, even slot
	T3/E3-Cable S-1	16-port cable for TDM CEM Interface Module, 42 inches cable length and 6.5 inches stub length, even slot
CABLE-16TDM-R3EL2	T3/E3-Cable M-3	16-port cable for TDM CEM Interface Module, 62 inches cable length and 10 inches stub length, even slot
	T3/E3-Cable M-2	16-port cable for TDM CEM Interface Module, 62 inches cable length and 7.5 inches stub length, even slot
	T3/E3-Cable M-1	16-port cable for TDM CEM Interface Module, 62 inches cable length and 6.5 inches stub length, even slot

Bundle PID	Cable Marking	Description
CABLE-16TDM-R3EL3	T3/E3-Cable L-3	16-port cable for TDM CEM Interface Module, 78 inches cable length and 10 inches stub length, even slot
	T3/E3-Cable L-2	16-port cable for TDM CEM Interface Module, 78 inches cable length and 7.5 inches stub length, even slot
	T3/E3-Cable L-1	16-port cable for TDM CEM Interface Module, 78 inches cable length and 6.5 inches stub length, even slot

RJ45 Cable Pinouts

T1 lines from individual subscribers are attached to RJ45 connectors on the front of the 24-port patch panel. Each RJ45 port accommodates an individual T1 subscriber line.

For the T1/E1 ports, see the [T1/E1 Port Pinout](#).

Installing Patch Panel

To install the brackets on the rear of the patch panel, perform these steps:

Procedure

-
- Step 1** Remove the larger (M4) rack mount screws (as indicated in the *Rack Mount Screws* figure below) from both sides. To secure the brackets, follow the instructions in Step-3.
- Step 2** Remove the patch panel rack-mount brackets from the accessory kit and position them beside the patch panel.
- Step 3** Position the brackets against the patch panel sides, and align with the screw holes. Secure the rack mount bracket to patch panel using a torque of 13.2 in.-lb (1.5 N-m) see the figure below.

Figure 74: Rack Mount Screws

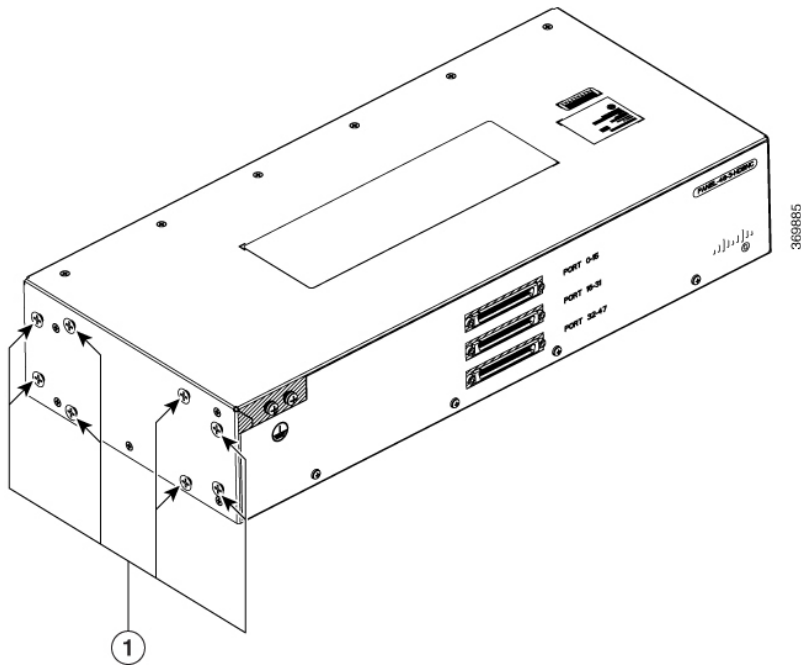

(1) Rack mount screws to secure rack mount brackets on both the sides.

Figure 75: Patch Panel Front View with Brackets

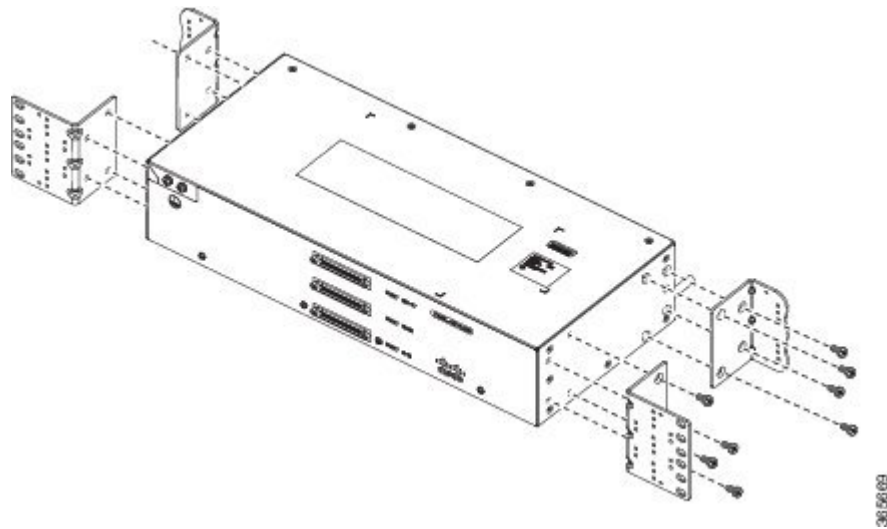

Step 4 Position the cable management guides against the mounting brackets on the patch panel, see the figure below.

Figure 76: Patch Panel Front View with Brackets and Guides

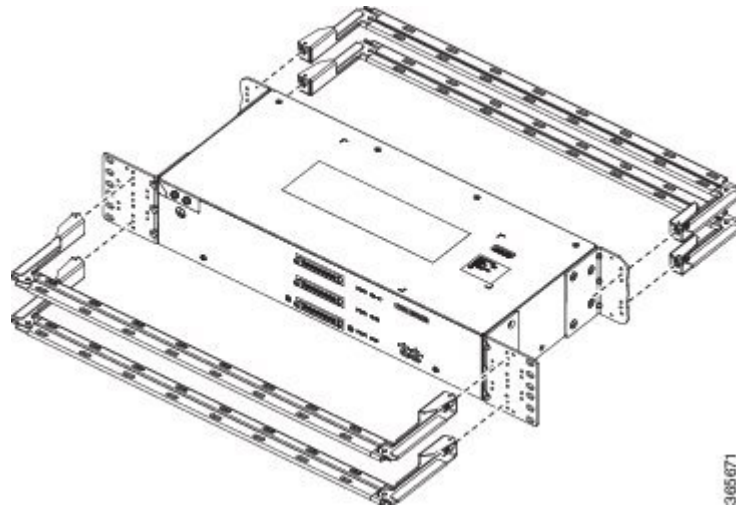
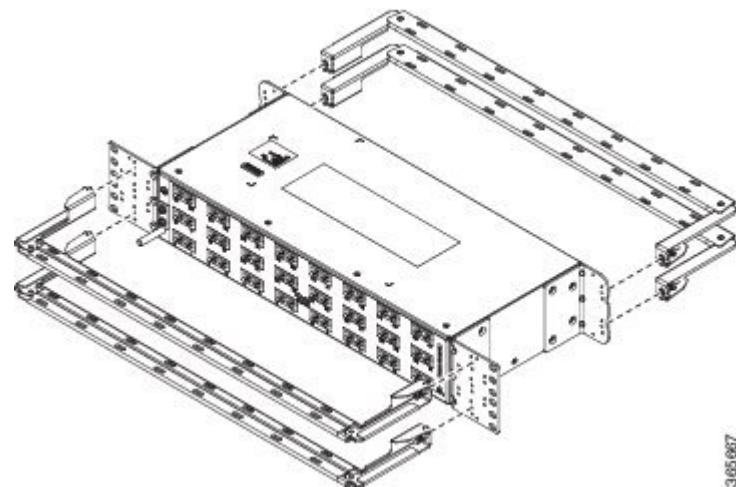

Figure 77: Patch Panel Rear View with Brackets and Guides



Step 5 Secure the guides to the brackets with the screws. The recommended maximum torque is 28 in.-lb (3.16 N-m).

Step 6 **Note** Cable brackets should be assembled according to the PID used as different PIDs have different set and quantity of brackets. Refer figures 110 to 115 for PID and cable bracket details.

Position the patch panel with brackets and guide onto the rack and secure with screws provided. The recommended maximum torque is 28 in.-lb (3.16 N-m), see the figure below.

Figure 78: Patch Panel Front View with Brackets and Guides Installed on Rack

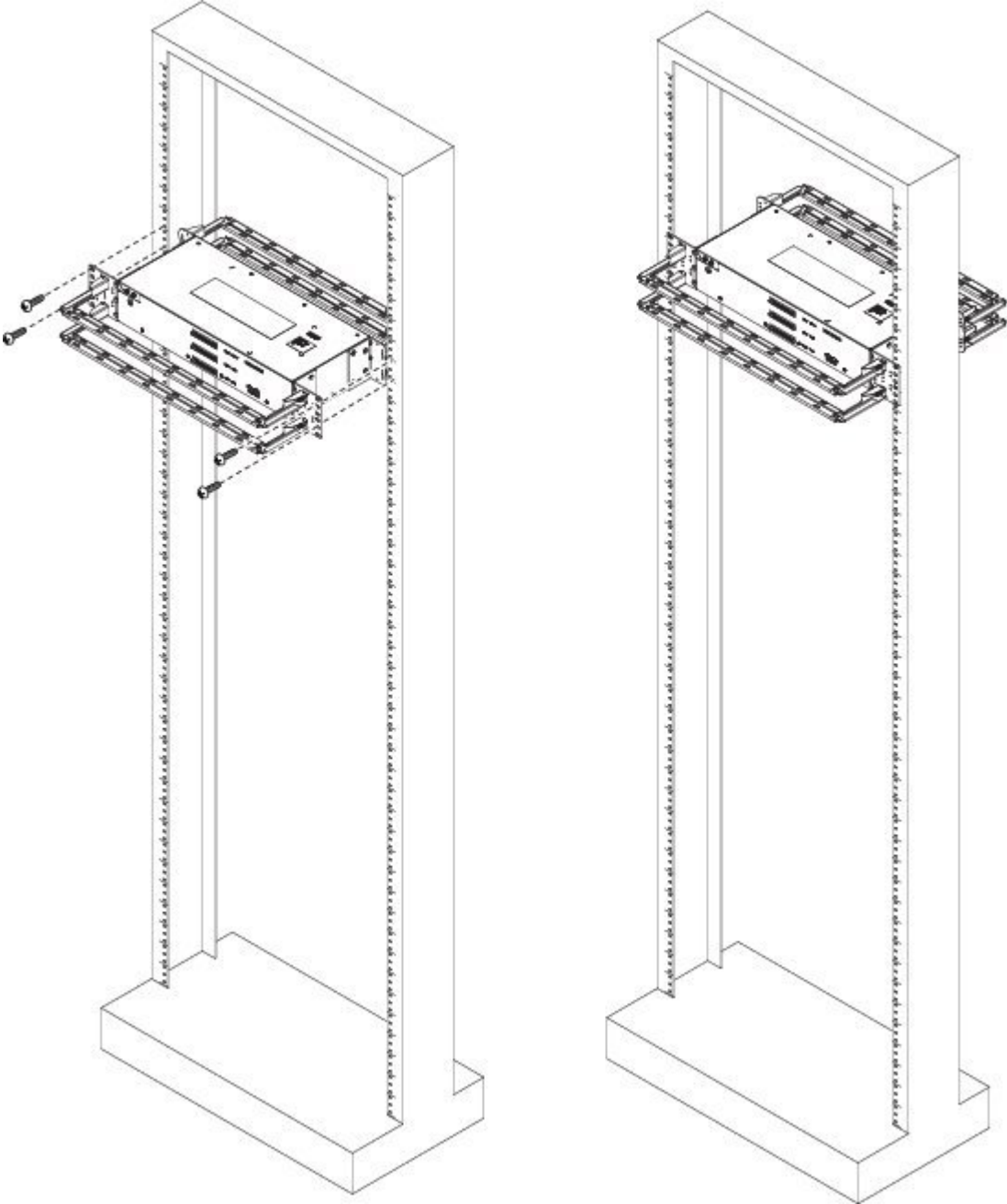

Figure 79: Patch Panel Rear View with Brackets and Guides Installed on Rack

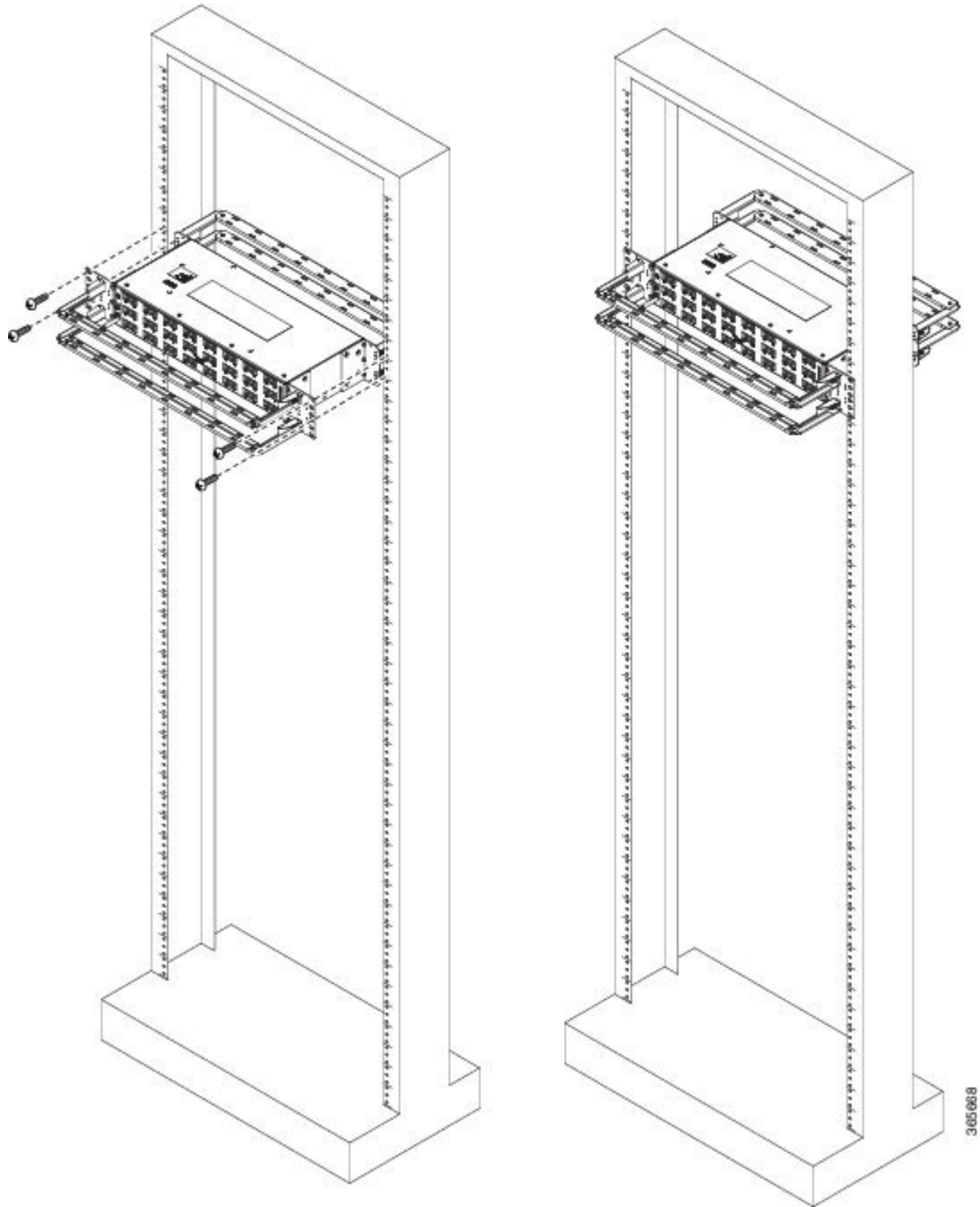

Figure 80: PANEL-16-DIN Patch Panel Mounting Installed on Rack

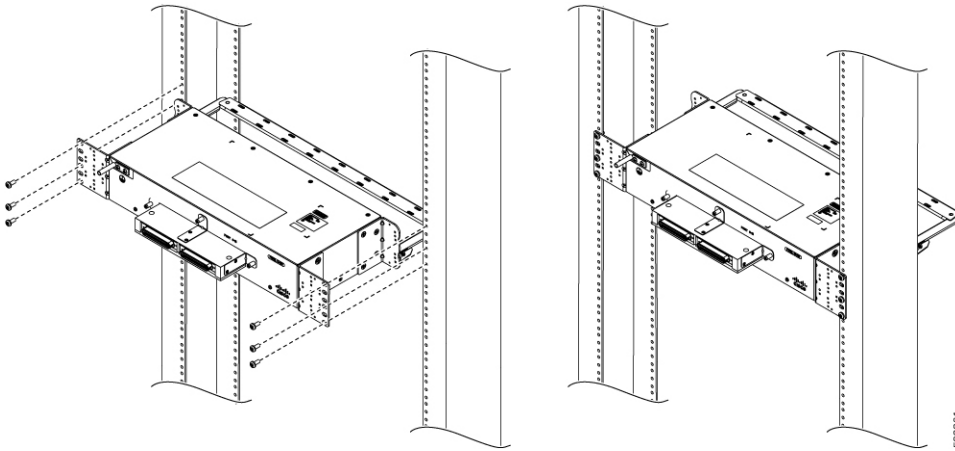

Figure 81: PANEL-48-1-AMP64

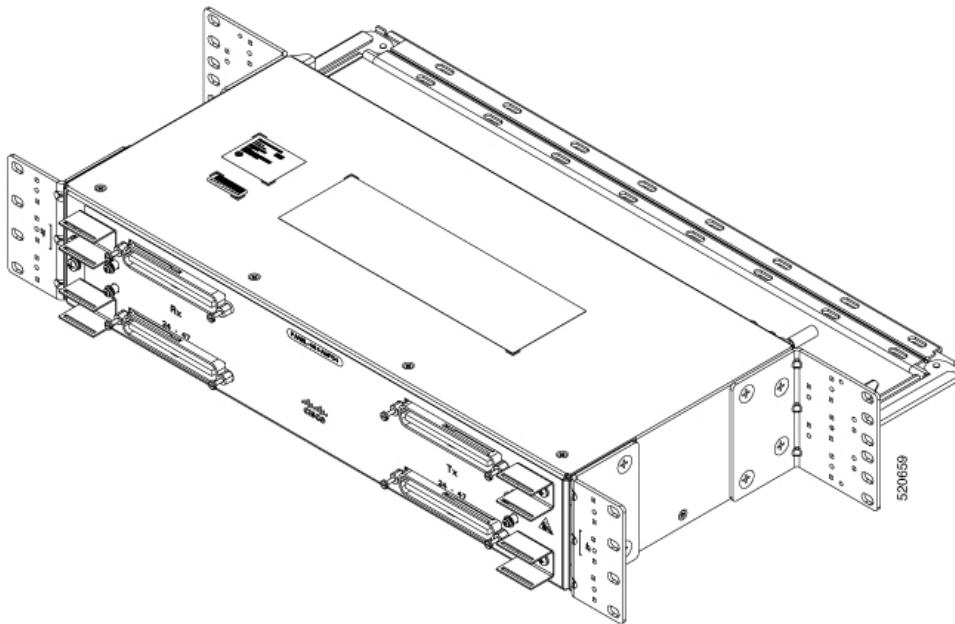
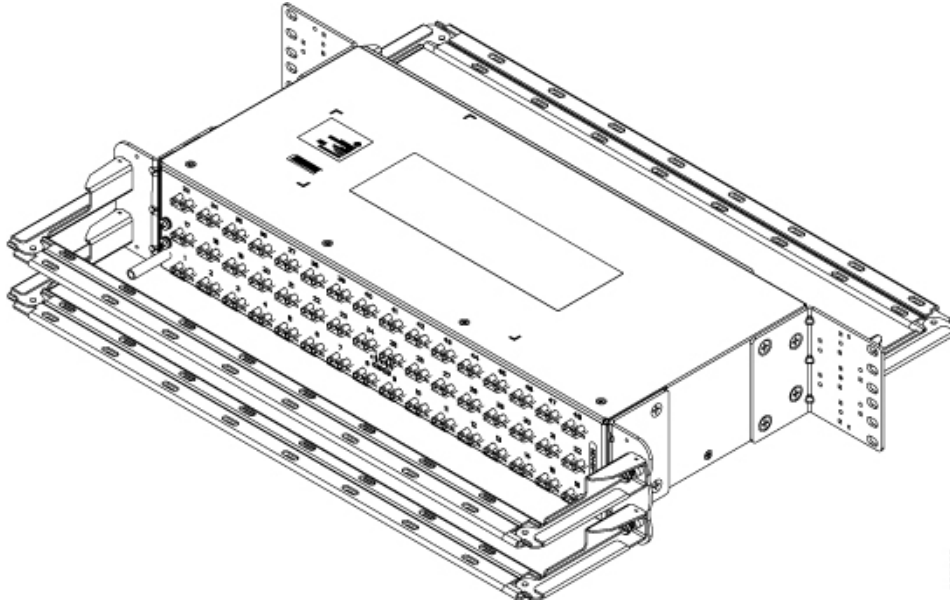
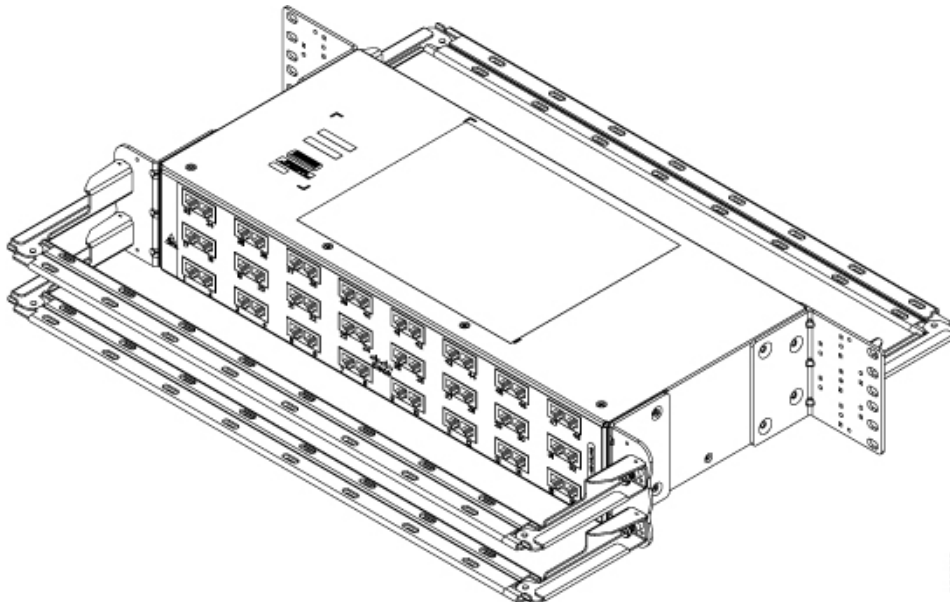

Figure 82: PANEL-48-1-DIN



520702

Figure 83: PANEL-48-1-RJ48

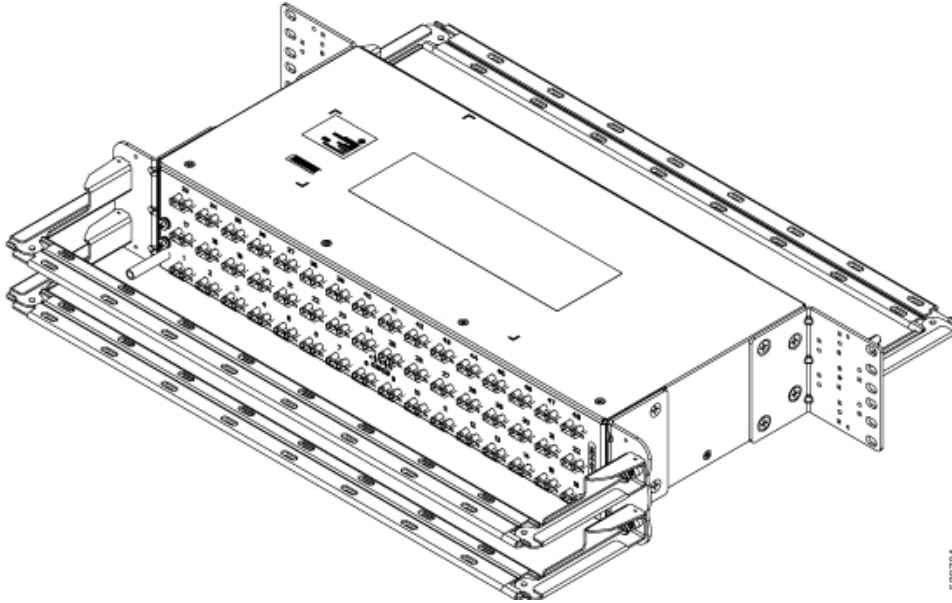

520703

Figure 84: PANEL-48-3-DIN

520704

Note The installation of PANEL-48-1-AMP64, PANEL-48-1-DIN, PANEL-48-1-RJ48, and PANEL-48-3-DIN is similar to the installation steps mentioned above.

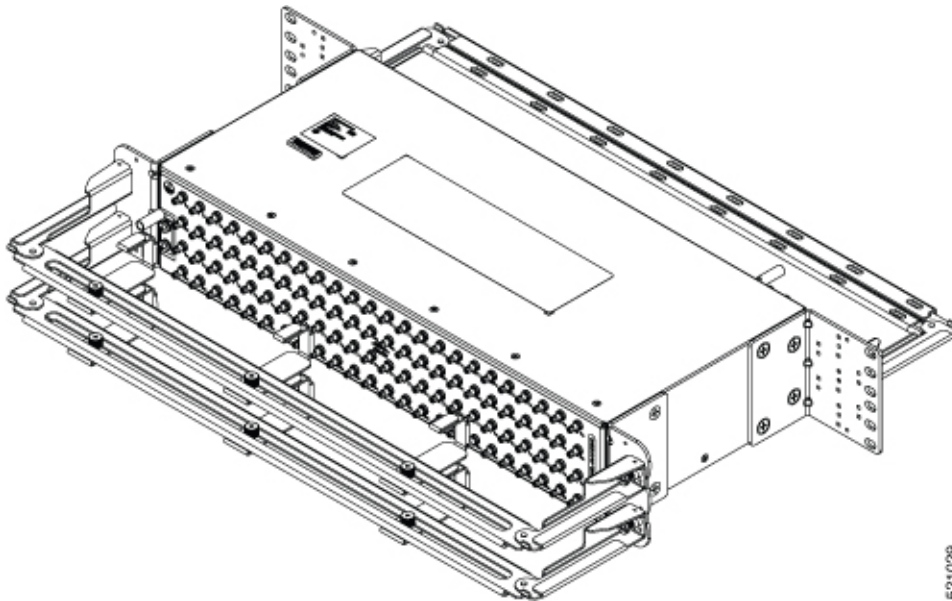
Figure 85: PANEL-48-3-HDBNC

521029

Figure 86: PANEL-144-1-AMP64

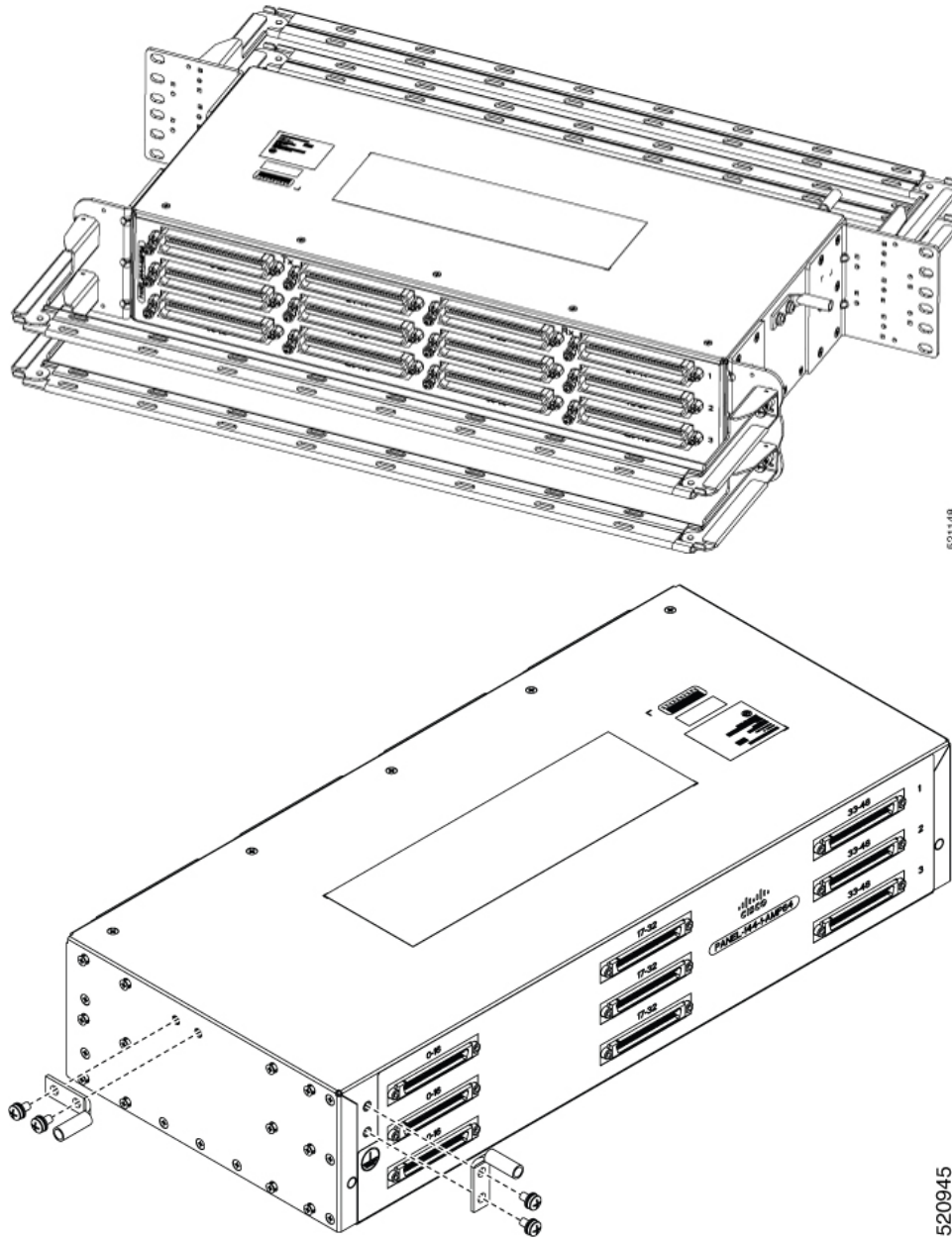
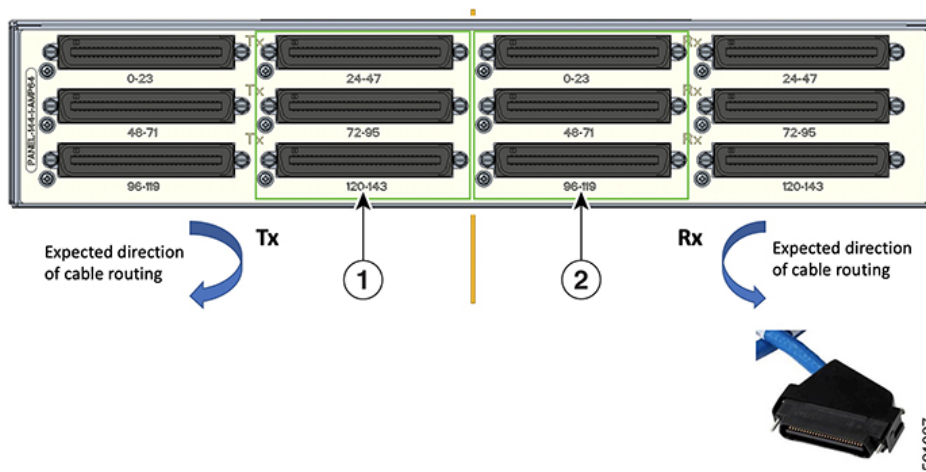

Figure 87: Example of 120° Exit Cable Hood



The following table shows details of the 120° exit cable hood:

Table 16: Cable Routing Recommendation for Panel-144-1-AMP64

1	120° exit cable hood with left routing should be used for centre ports on the Tx side.
2	120° exit cable hood with right routing should be used for centre ports on the Rx side.

Ground Connection for Patch Panel

To ensure that the chassis ground connection that you provide is adequate, you need the following parts and tools:

- Ratcheting torque screwdriver with Phillips head that exerts up to 15 in.-lb (1.69 N-m) of pressure for attaching the ground wire to the router
- Crimping tool as specified by the ground lug manufacturer
- 6 AWG or larger copper wire for the ground wire
- Wire-stripping tools appropriate to the wire you are using



Caution

Before making connections to the Cisco NCS 4206, ensure that you disconnect the power at the circuit breaker. Otherwise, severe injury to you or damage to the chassis may occur.



Warning

This equipment must be grounded. Never defeat the ground conductor or operate the equipment in the absence of a suitably installed ground conductor. Contact the appropriate electrical inspection authority or an electrician if you are uncertain that suitable grounding is available. Statement 1024



Warning Use copper conductors only. Statement 1025



Warning When installing the unit, the ground connection must always be made first and disconnected last. Statement 42

Grounding points on patch panel may vary between different PIDs.

Install 3G Patch Panel

You can choose to either set up the Cisco ASR 903 3G patch panel on a rack or wall mount it.

Install Rack Brackets

Procedure

- Step 1** Connect the grounding lugs using a crimping tool (as specified by the ground lug manufacturer), crimp the ground lug to the ground wire.
- Step 2** Use a 6 AWG ground wire to connect the other end to a suitable grounding point at your site.

Figure 88: Patch Panel Grounding - Single

Figure 89: Patch Panel Grounding - Dual



- Step 3** Position the patch panel in the rack as follows:
- If the front of the patch panel is at the front of the rack, insert the rear of the chassis between the mounting posts.
 - If the rear of the patch panel is at the front of the rack, insert the front of the chassis between the mounting posts.
- Step 4** Align the mounting holes in the bracket with the mounting holes in the equipment rack.

Figure 90: Installing the Patch Panel - Single in a 19-inch Rack

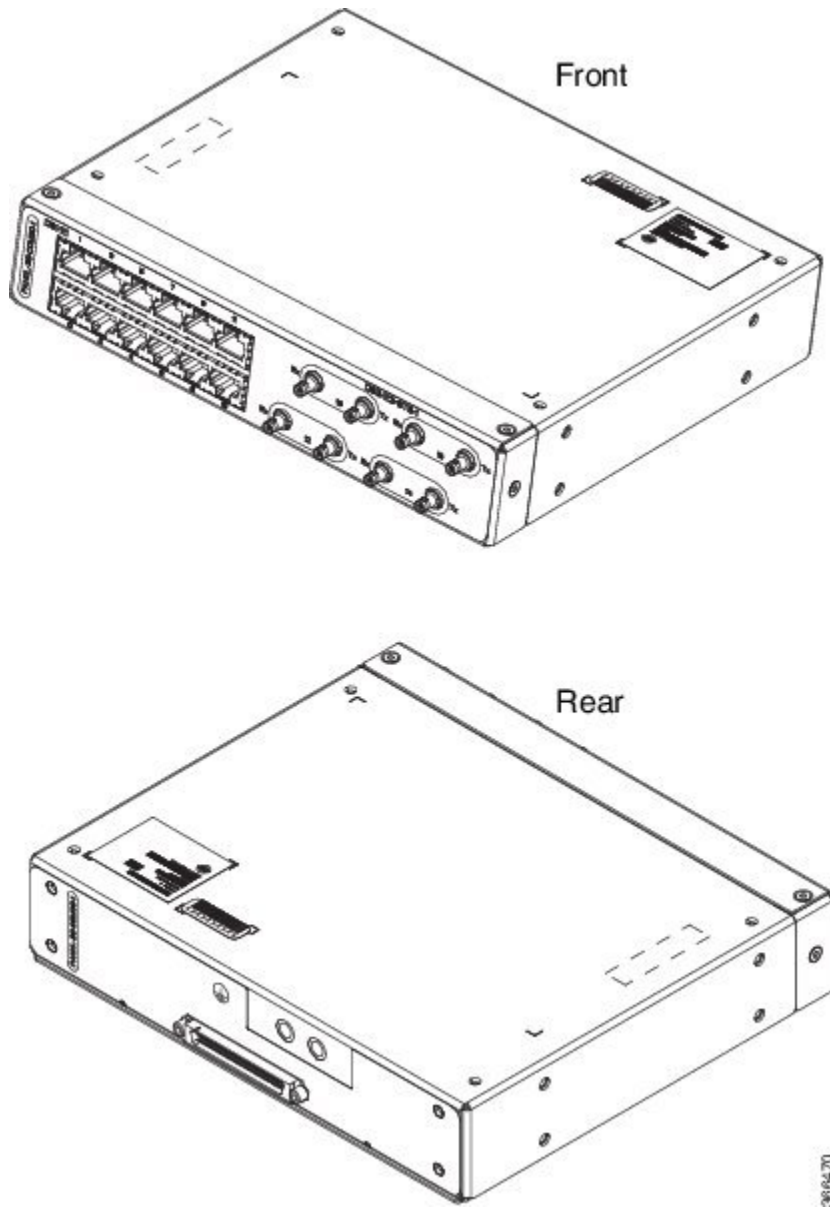
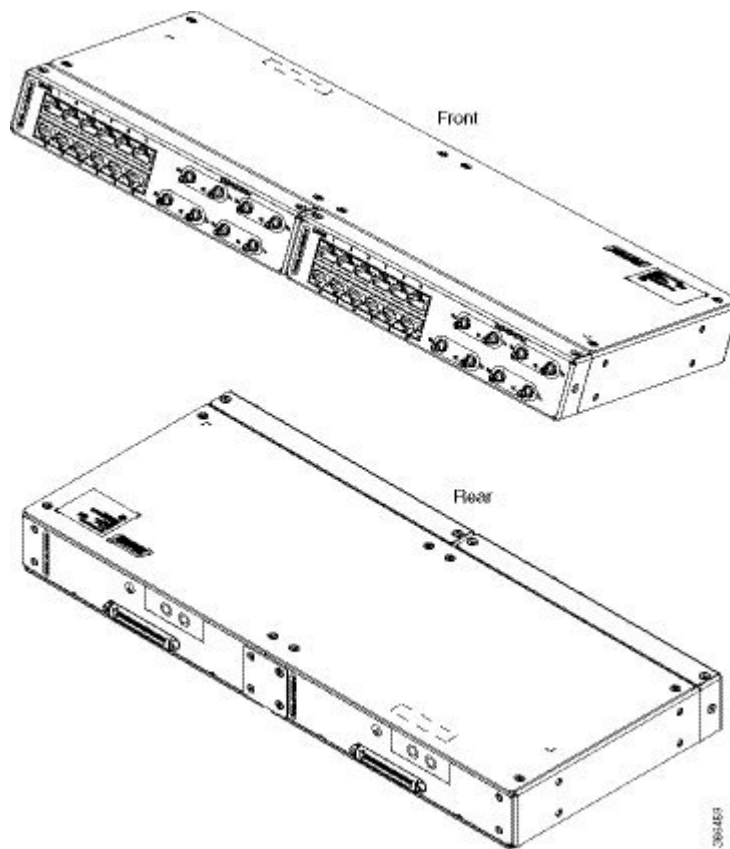
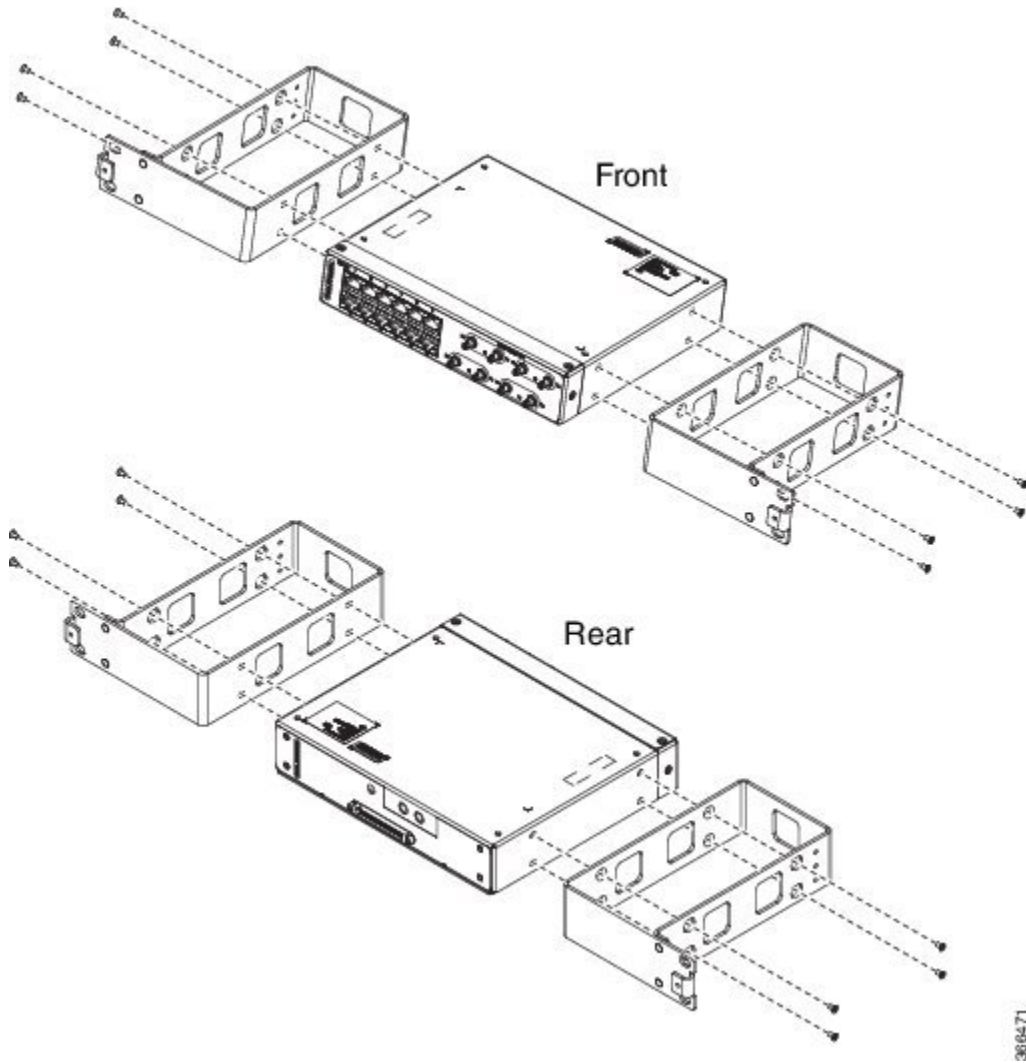

386471

Figure 91: Installing the Patch Panel - Dual in a 19-inch Rack

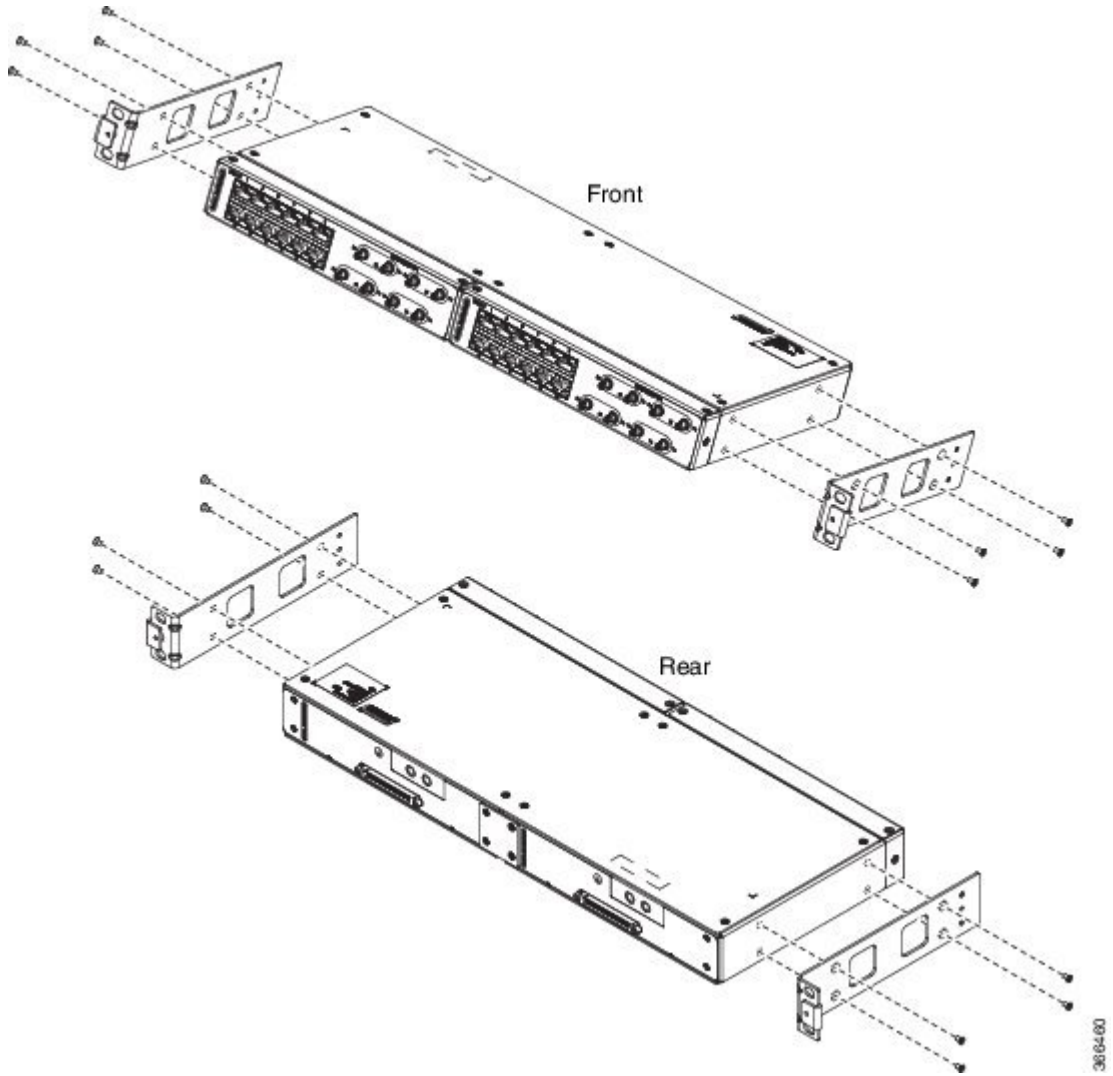

Figure 92: Installing the Patch Panel - Single in a 21-inch Rack

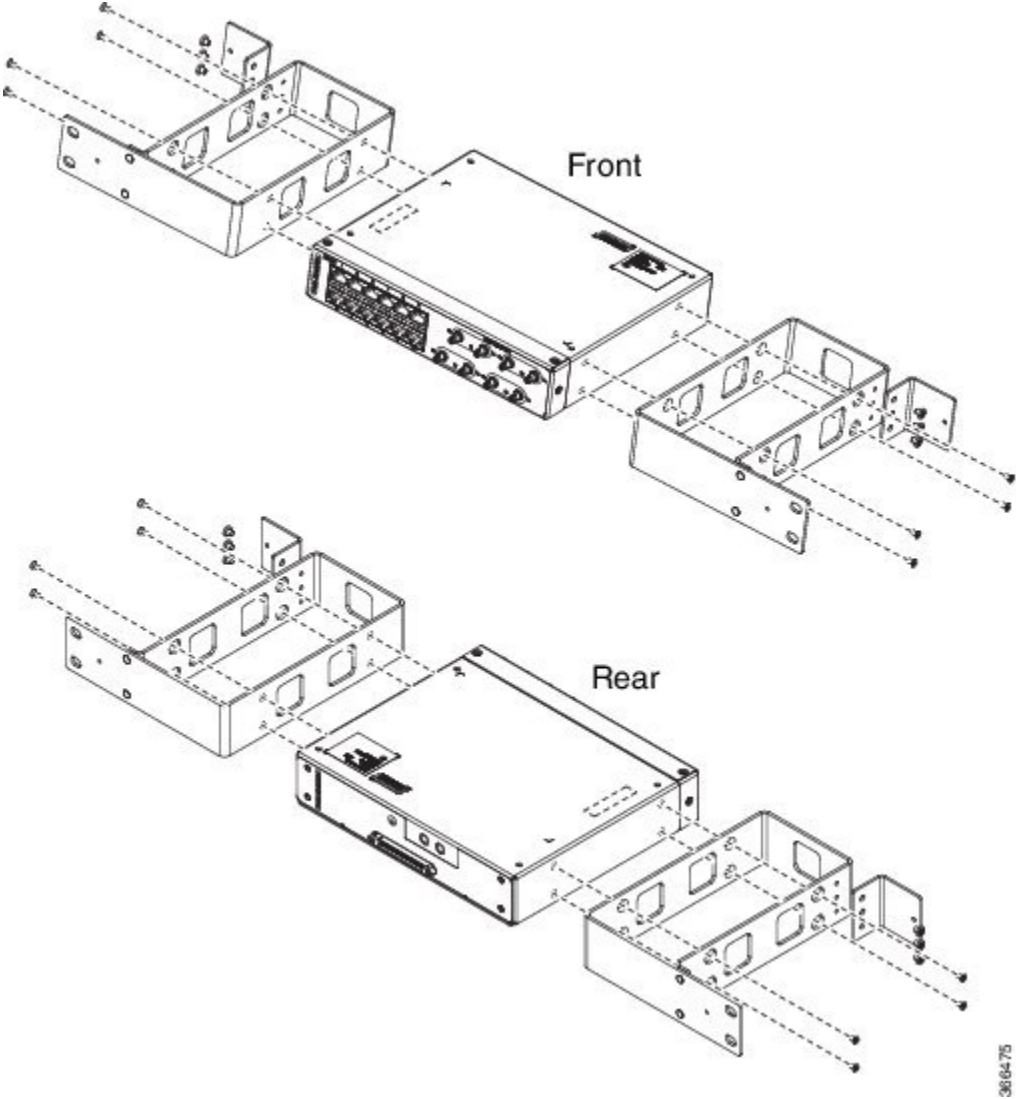

Figure 93: Installing the Patch Panel - Dual in a 21-inch Rack

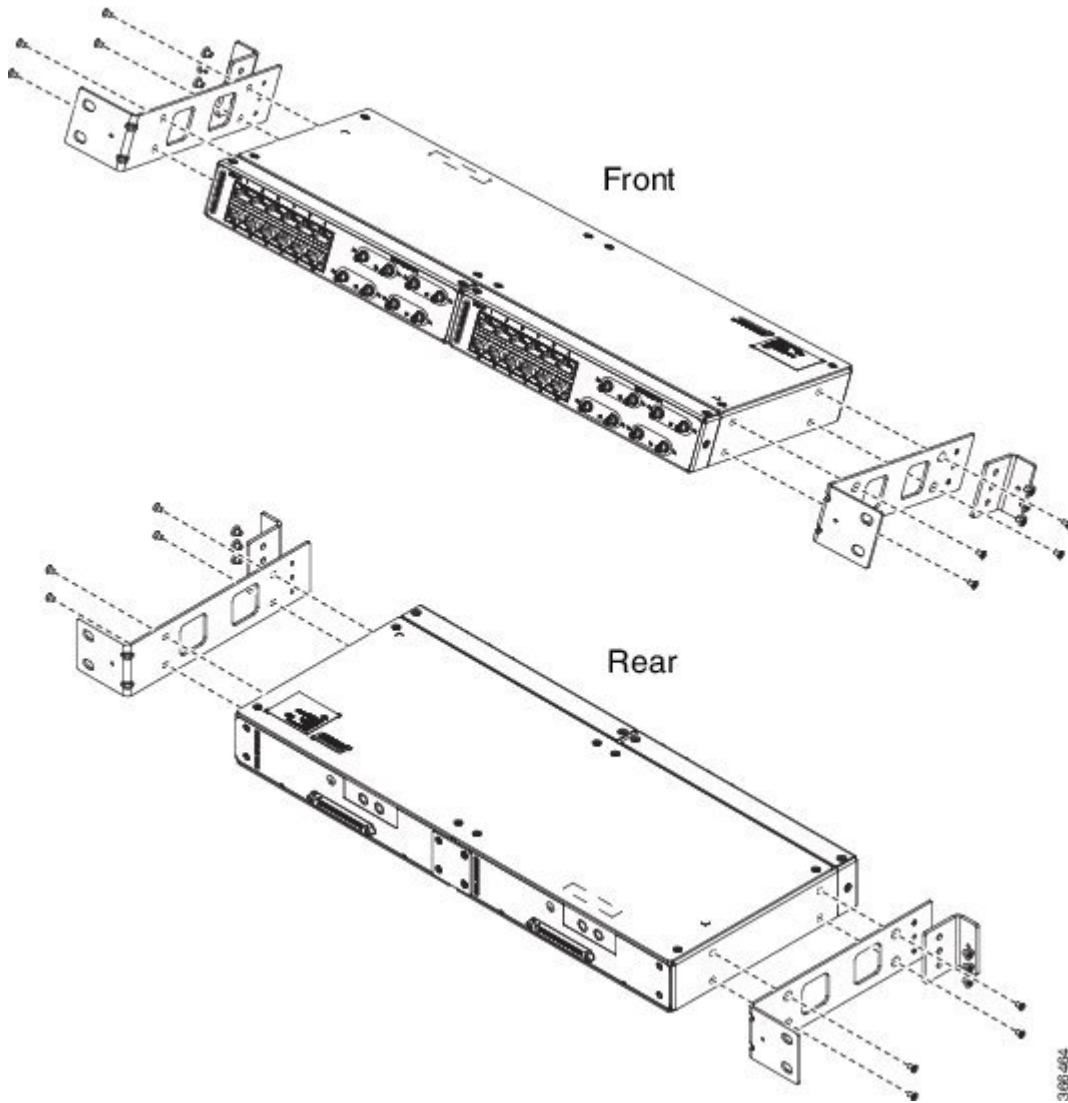

Figure 94: Installing the Patch Panel - Single in a 23-inch Rack

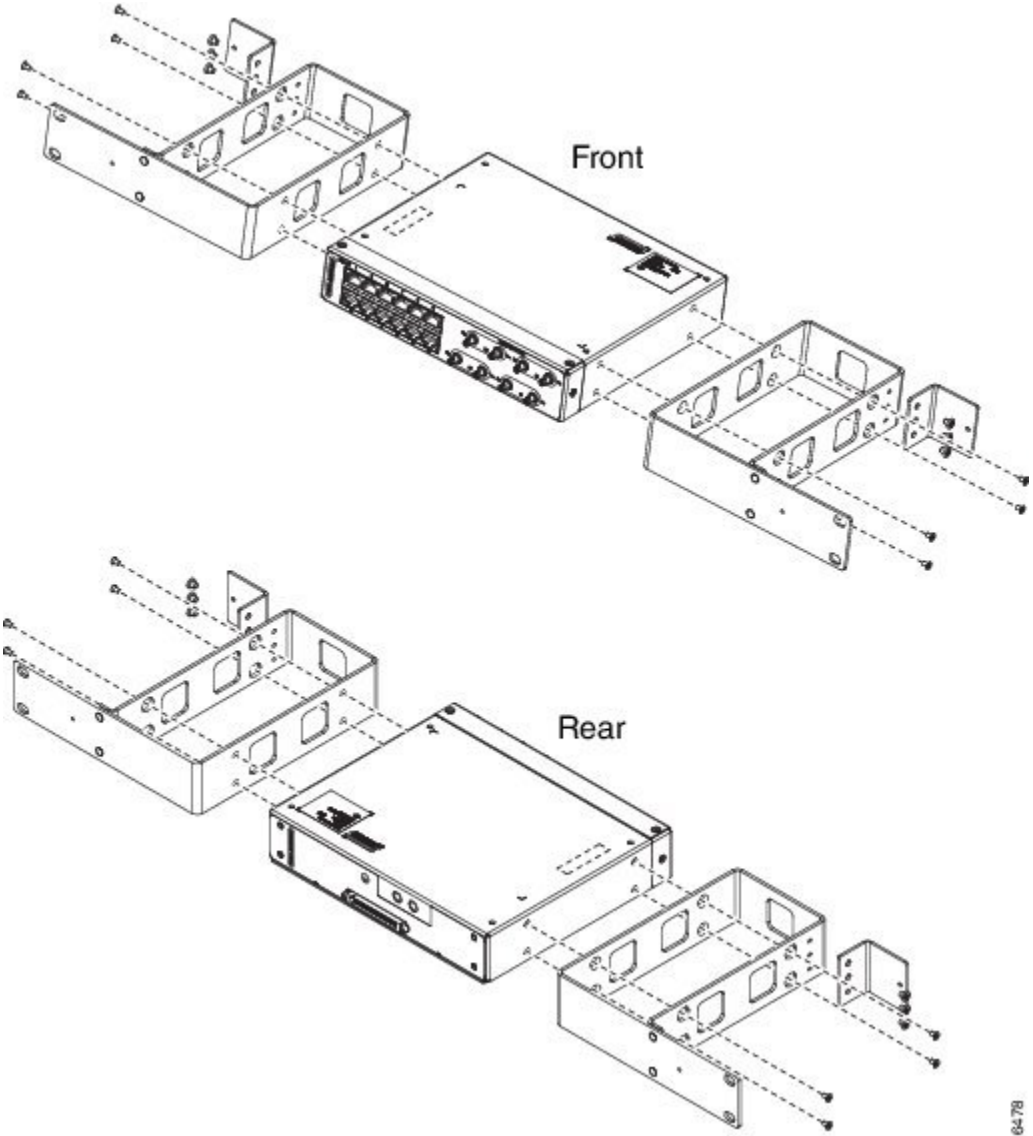
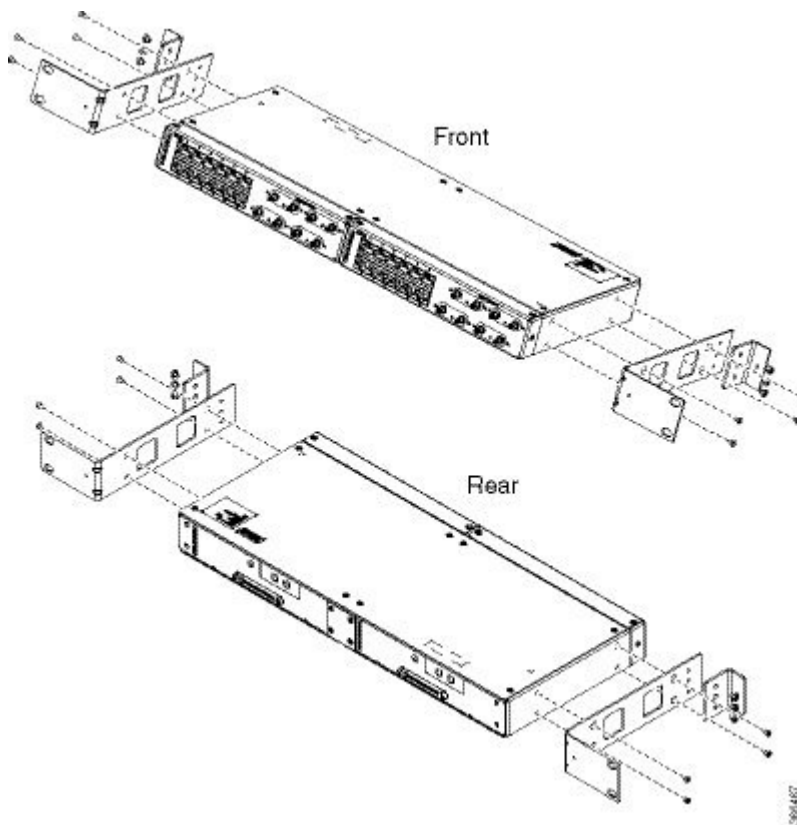

Figure 95: Installing the Patch Panel - Dual in a 23-inch Rack



- Step 5** Secure the brackets to the chassis with the screws. The recommended maximum torque is 28 in.-lb (3.16 N-m).
- EIA 19 and 23 inches mounting brackets for both single and double 3G interface module patch panels.
 - ETSI 21 inches mounting brackets for both single and double 3G interface module patch panels.

Set up 3G Patch Panel on Rack

To install the optional cable management brackets, perform these steps:

Procedure

- Step 1** Position the cable management brackets against the front of the chassis and align the screw holes, as shown in the figure.
- Step 2** Secure the cable management brackets with the screws. The recommended maximum torque is 10 in.-lb (1.12 N-m).

Figure 96: Attaching 19-inch Brackets to Patch Panel - Single

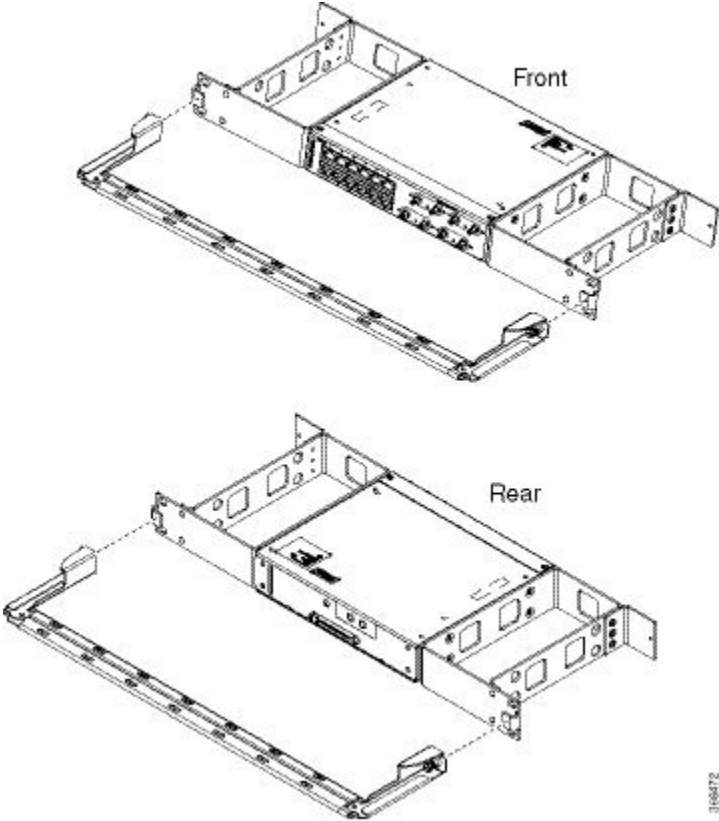

Figure 97: Installing 19-inch Brackets on to Rack - Single

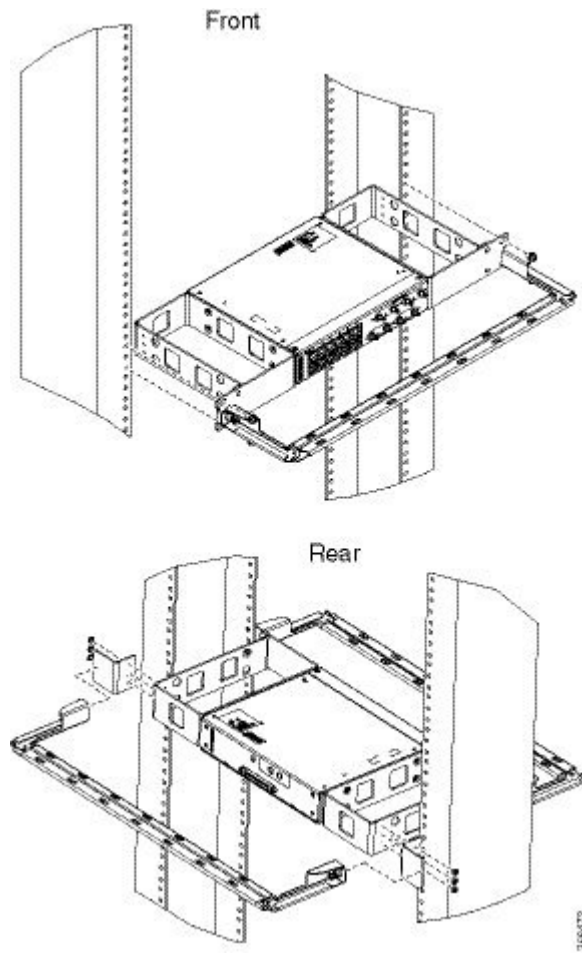
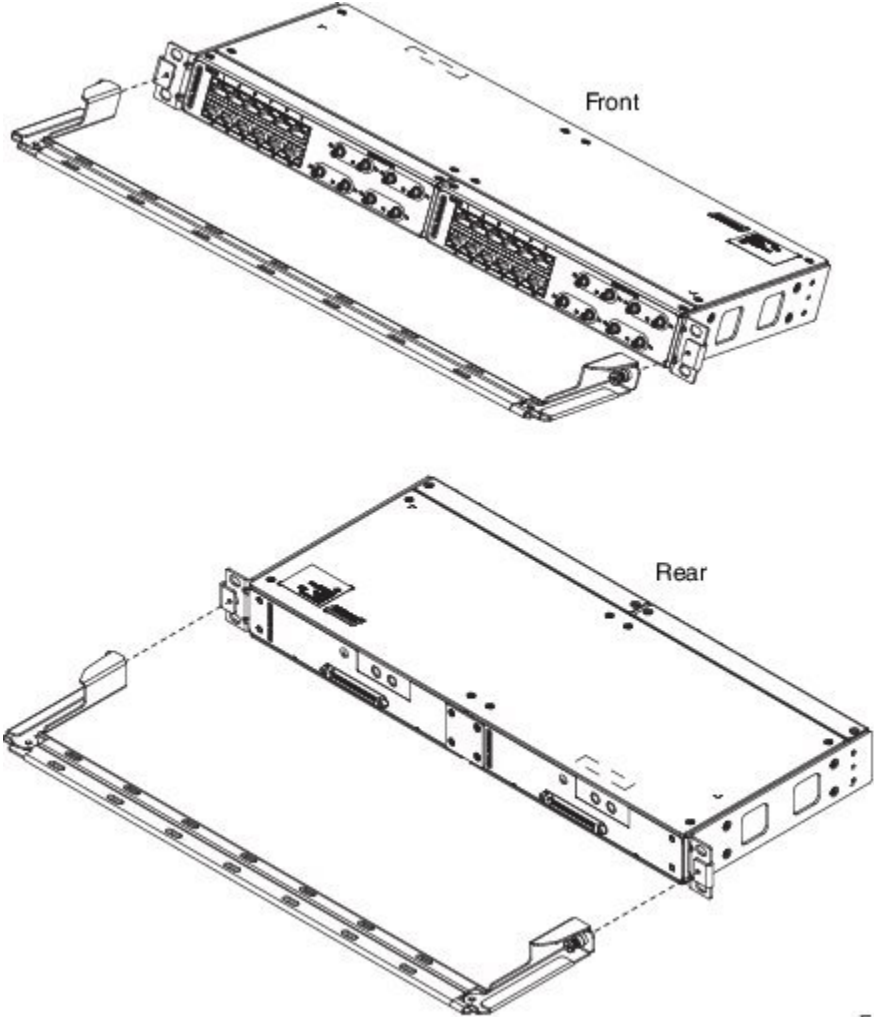

Figure 98: Attaching 19-inch Brackets to Patch Panel - Dual



38164-01

Figure 99: Installing 19-inch Brackets on to Rack - Dual

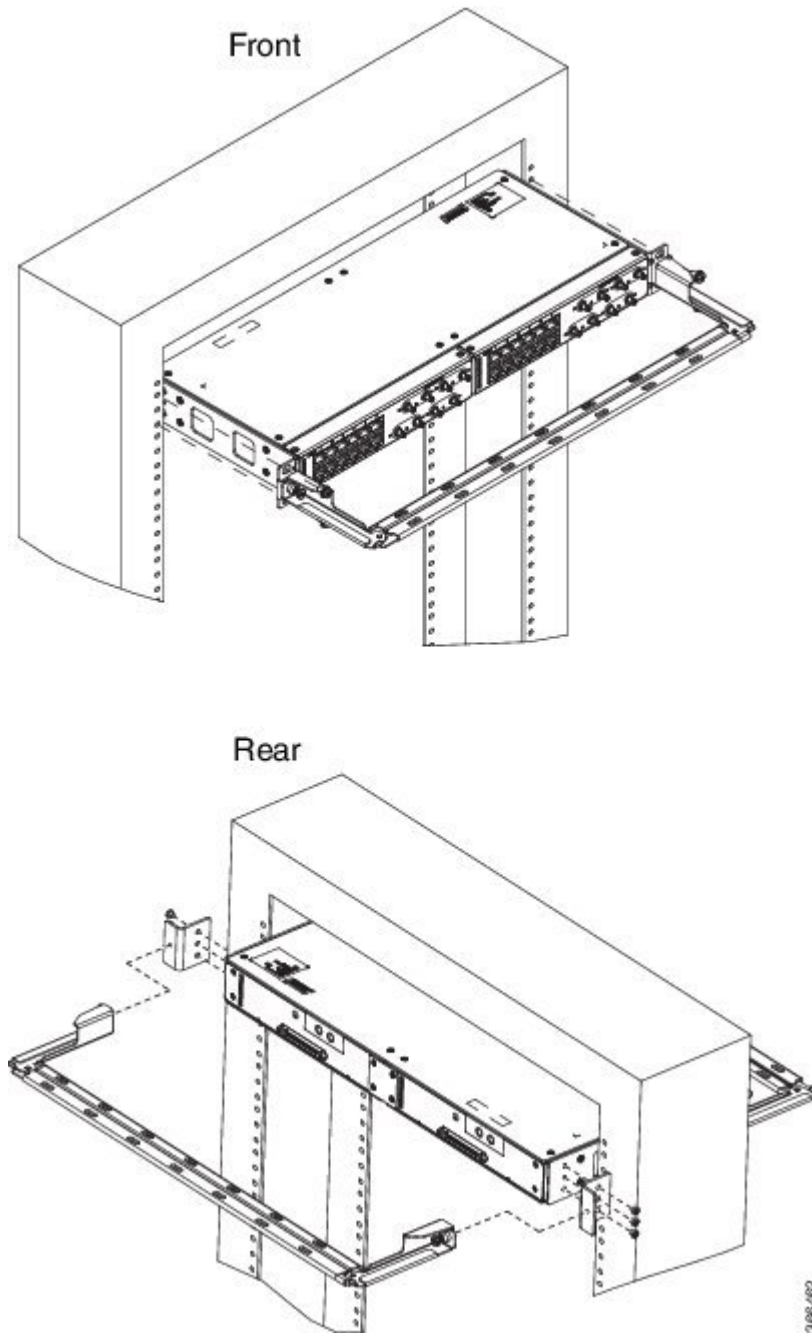
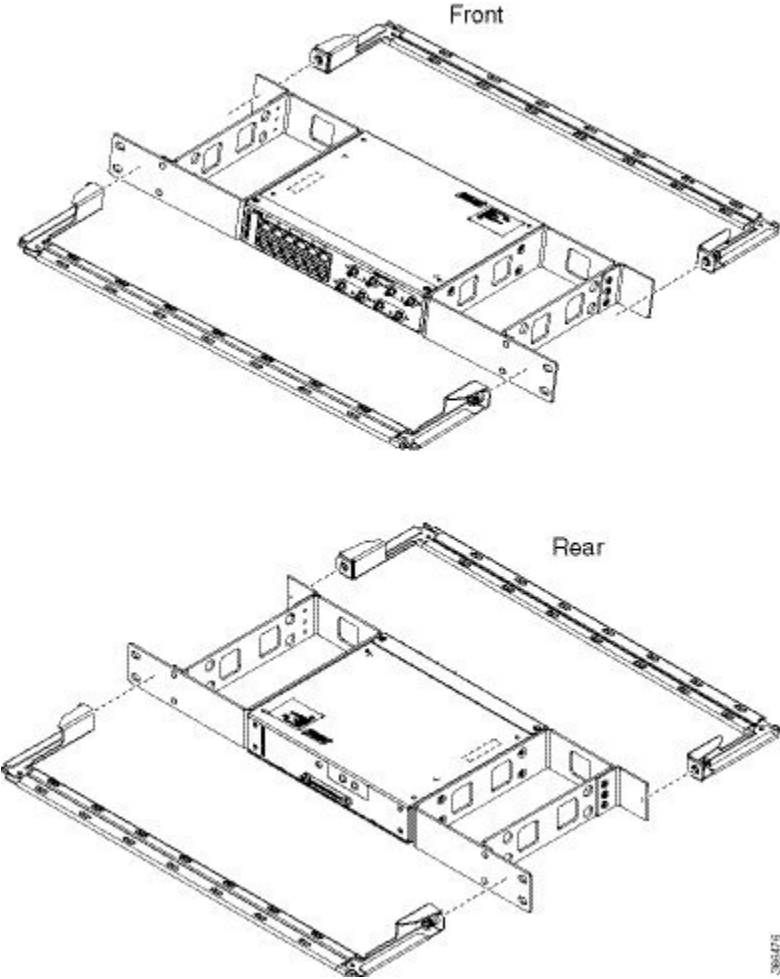

Figure 100: Attaching 21-inch Brackets to Patch Panel - Single



386475

Figure 101: Installing 21-inch Brackets on to Rack - Single

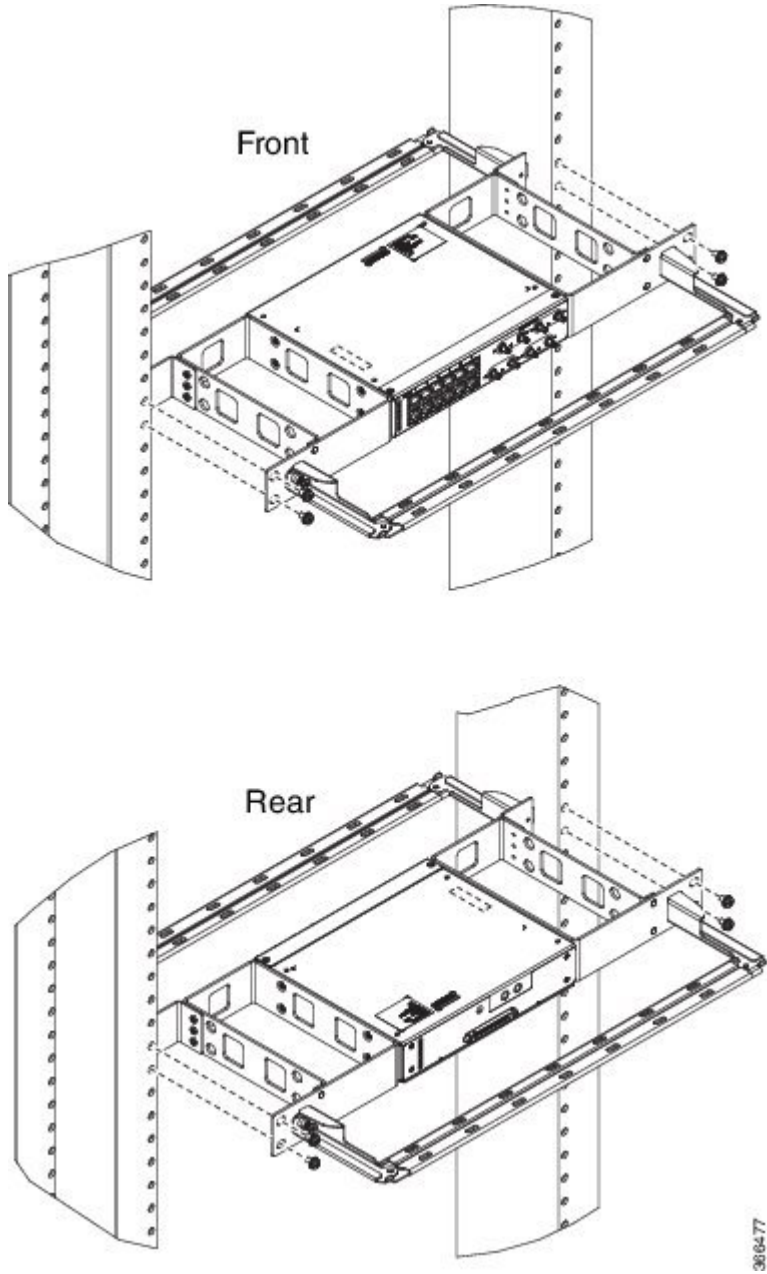
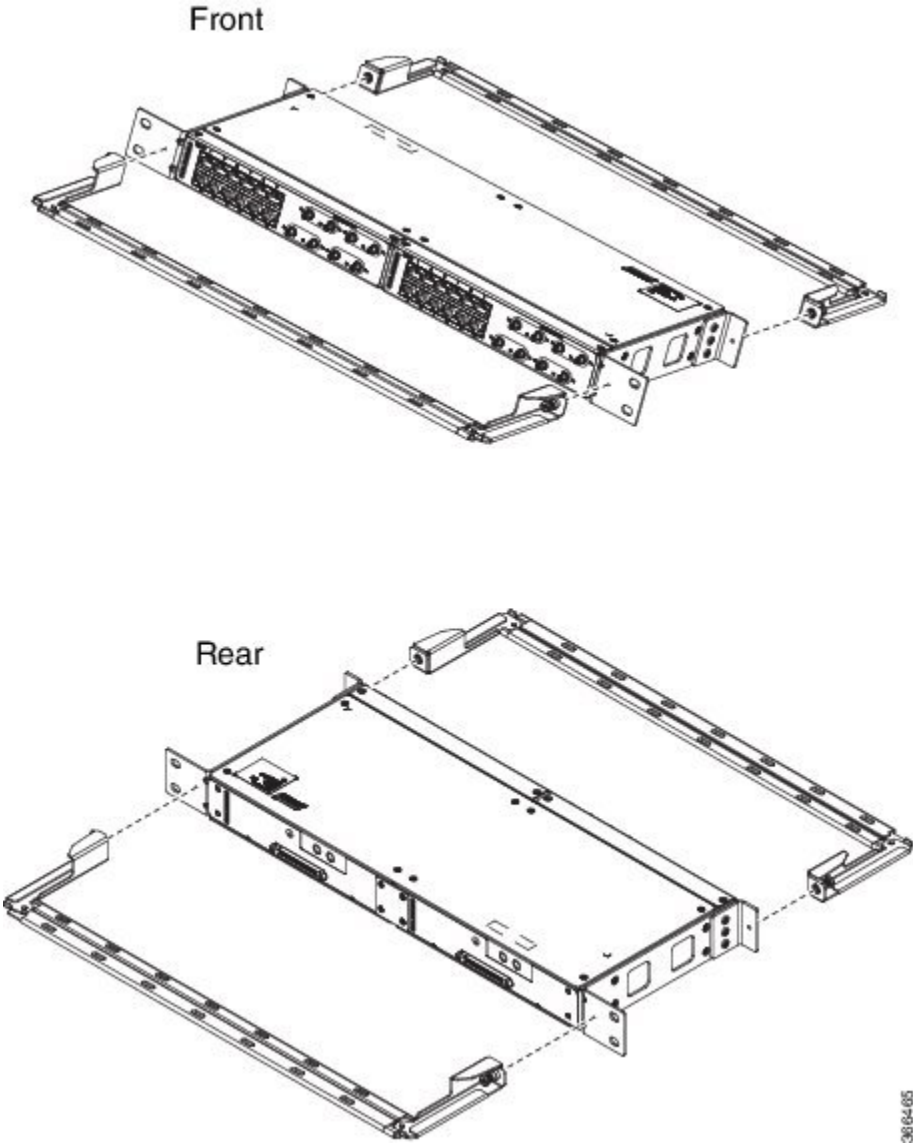

Figure 102: Attaching 21-inch Brackets to Patch Panel - Dual



38164-05

Figure 103: Installing 21-inch Brackets on to Rack - Dual

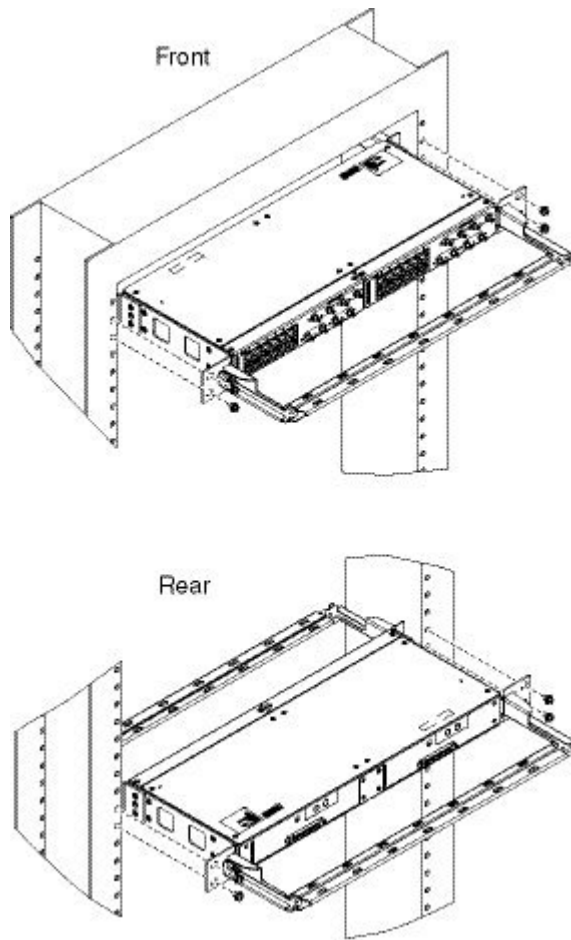
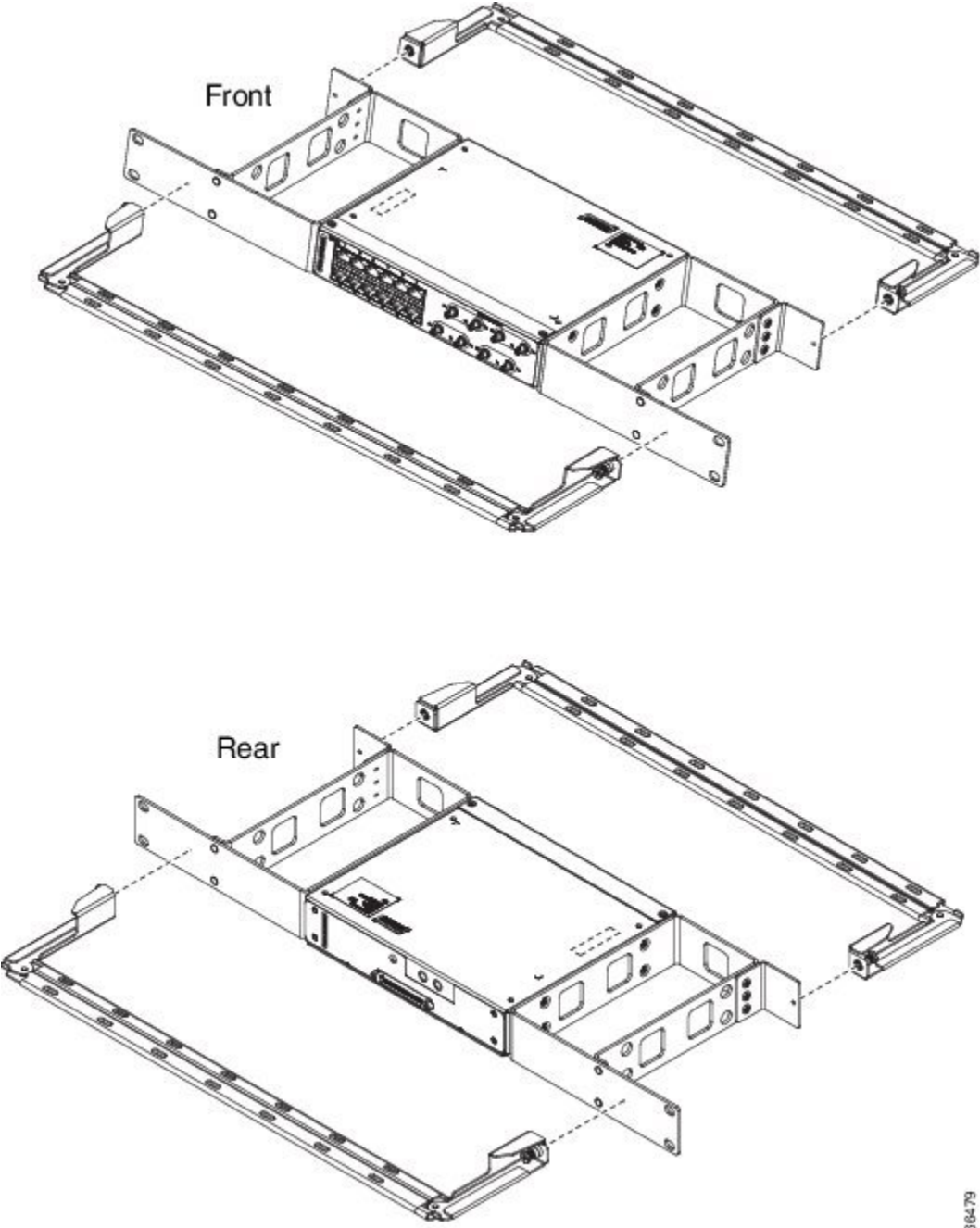

Figure 104: Attaching 23-inch Brackets to Patch Panel - Single



38184-73

Figure 105: Installing 23-inch Brackets on to Rack - Single

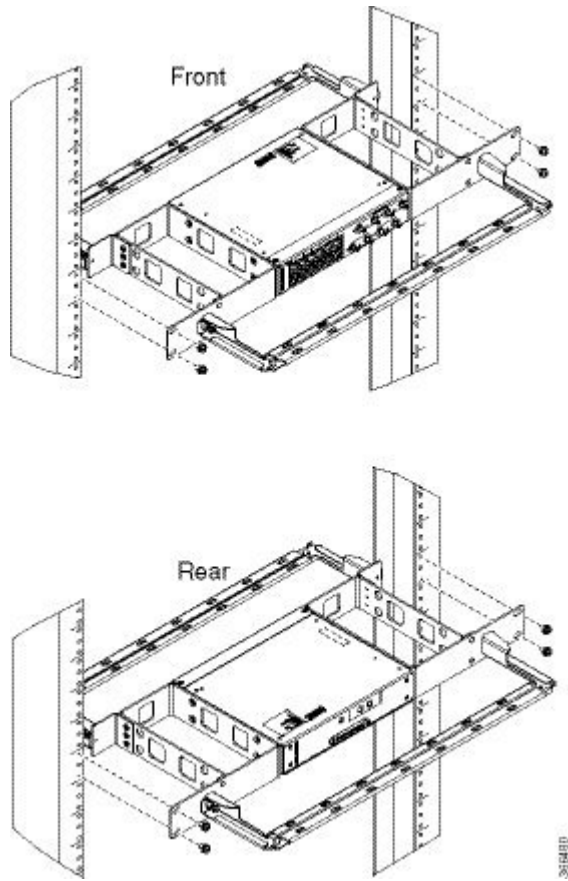
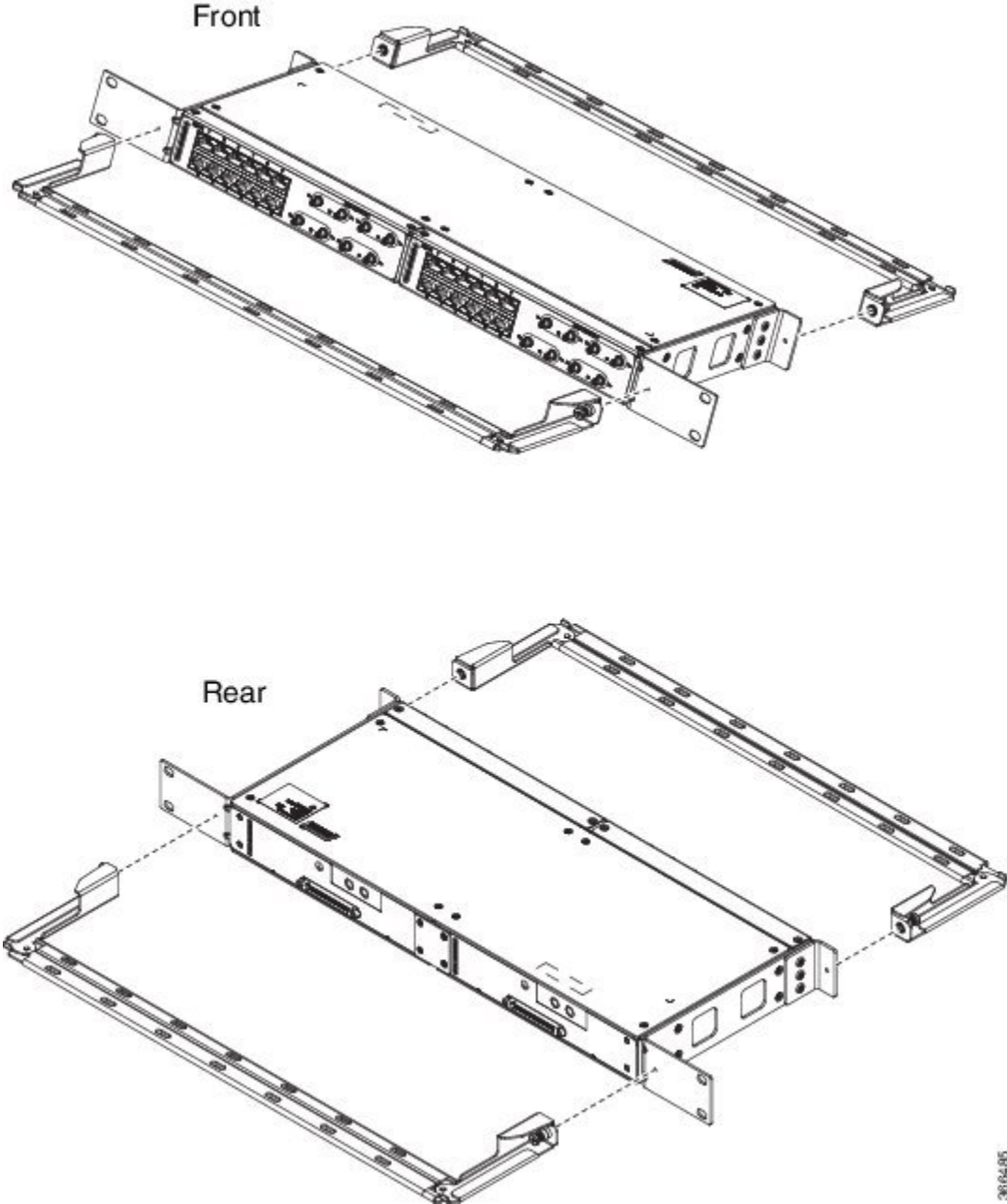
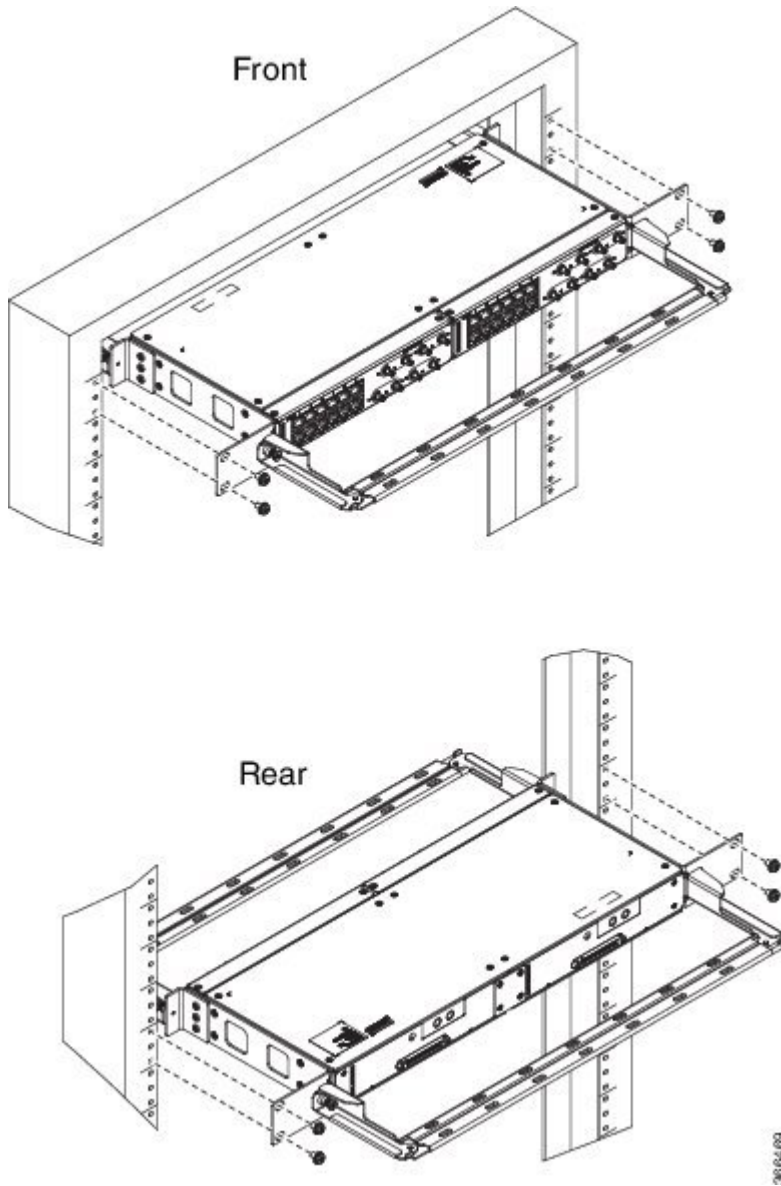

Figure 106: Attaching 23-inch Brackets to Patch Panel - Dual



3664-85

Figure 107: Installing 23-inch Brackets on to Rack - Dual



Wall Mount 3G Patch Panel

Before you begin

You must first install the mounting brackets and cable guides on to the patch panel before you mount it on the wall. You can use the same rack mount brackets (700-113653-01) for wall mount.

Procedure

Step 1 Remove the mounting brackets from the accessory kit and position them beside the device.

Note You can install the brackets as shown in the figure.

Figure 108: Wall Mount - Single

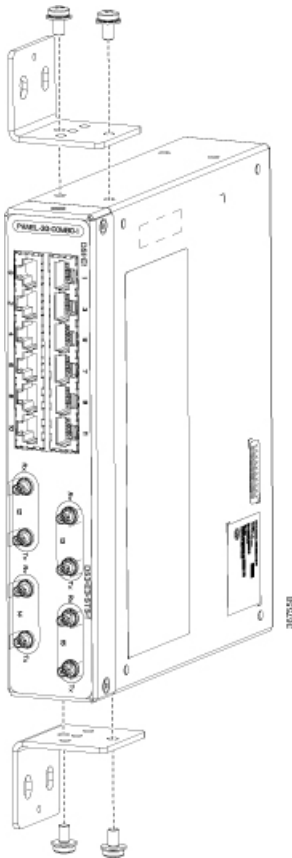
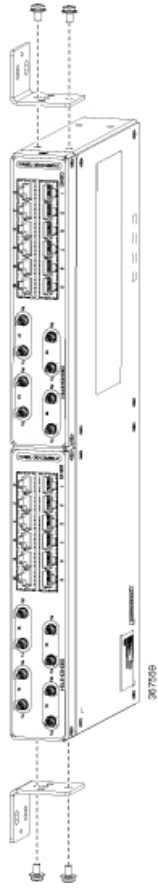

Figure 109: Wall Mount - Dual



Step 2 Secure the bracket to the device with the recommended maximum torque of 10 inch-pounds (1.1 newton meters).

Step 3 Position the device vertically on the wall.

Caution Before mounting the device, ensure that all unused holes at the sides of the device are protected with screws.

Step 4 Use a tape measure and level to verify that the device is installed straight and on level.

Patch Panel Dimensions

Following are the various patch panel dimensions.

Figure 110: Patch Panel Without Brackets

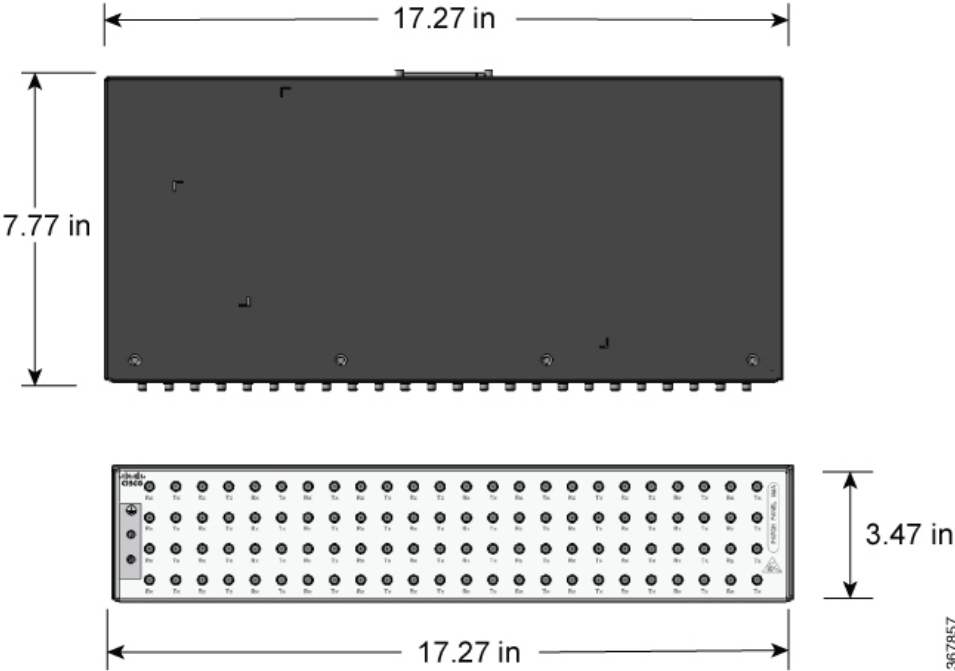

Figure 111: Patch Panel With Brackets

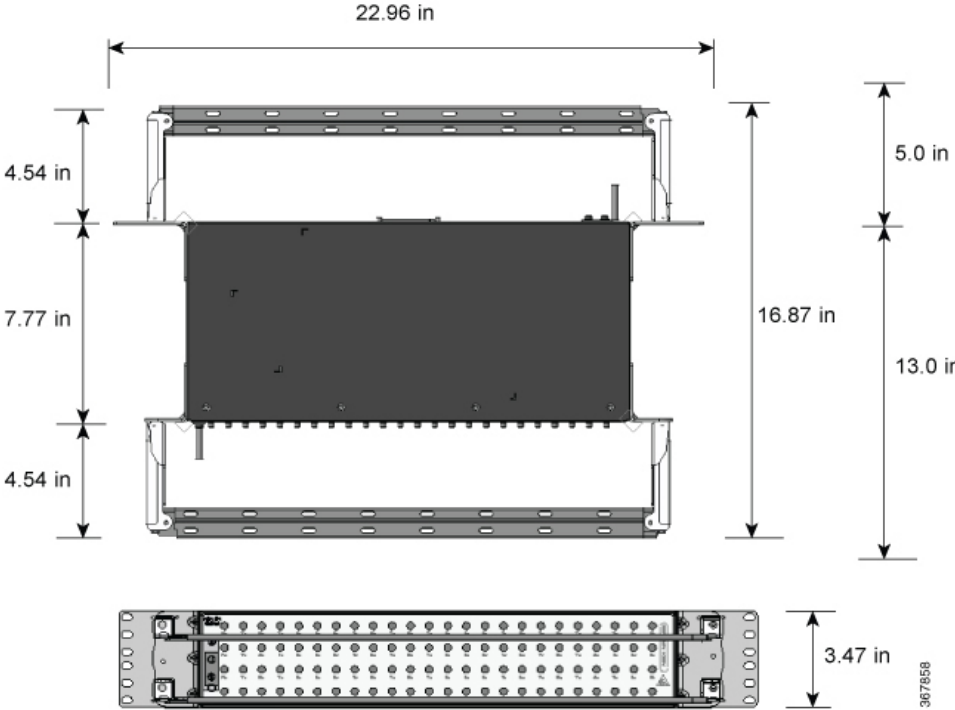

Figure 112: AMP64 Patch Panel With Brackets

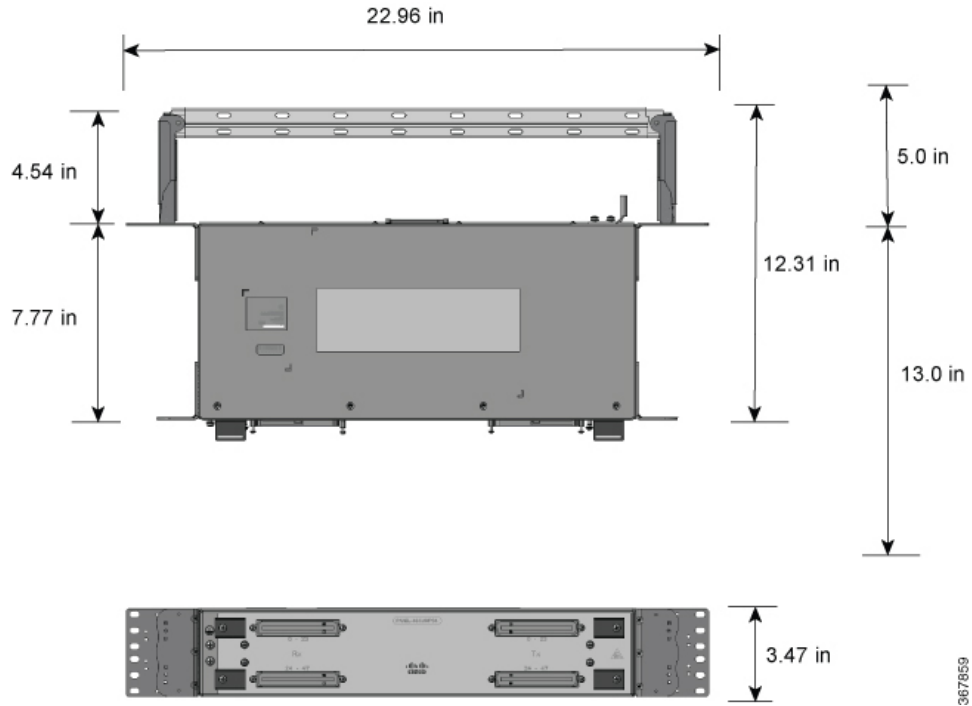

Figure 113: 3G Patch Panel Without Brackets - Single

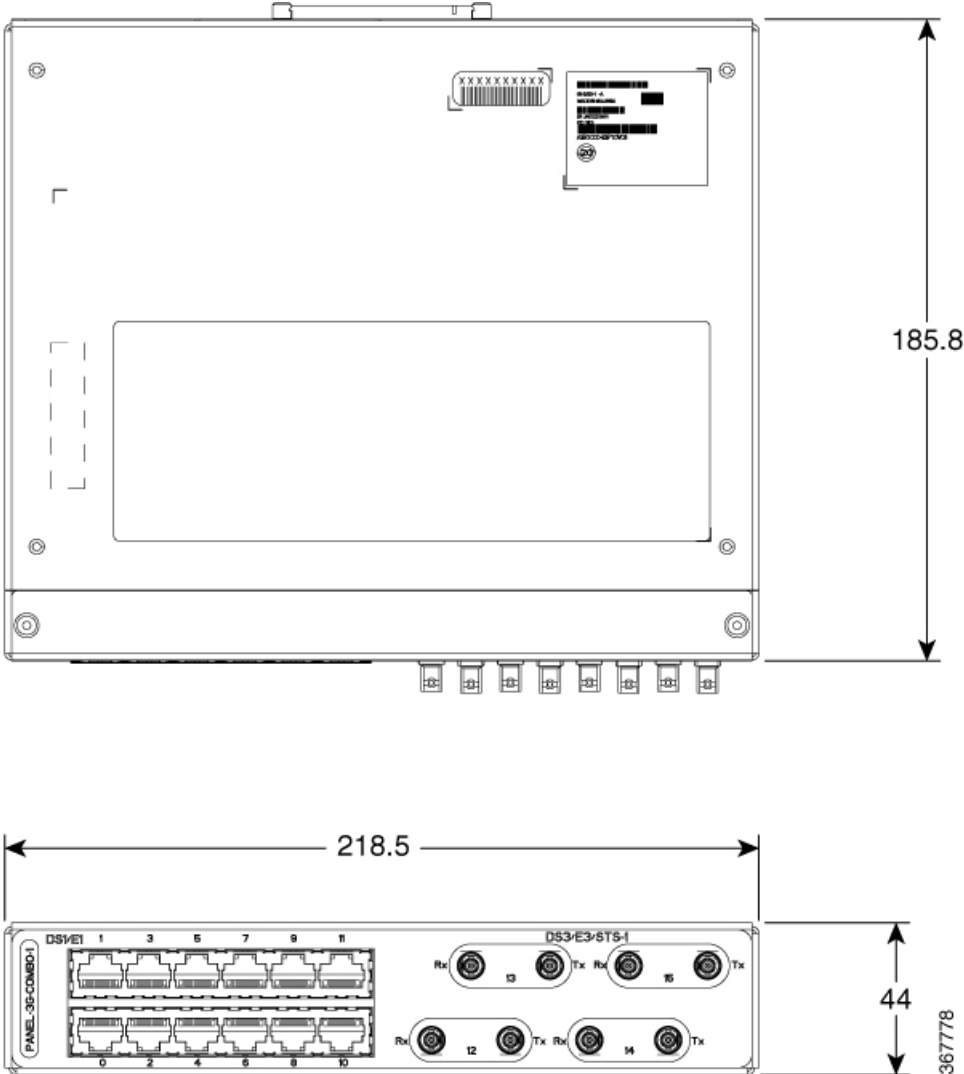
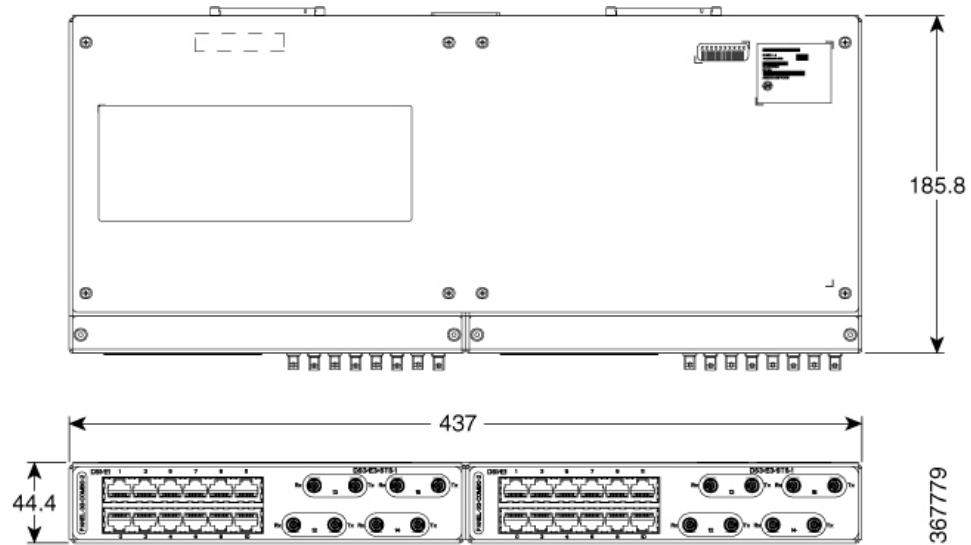

Figure 114: 3G Patch Panel Without Brackets - Dual



Patch Panel Pinout

Given below are the pinout information for the regular crossover and the straight-through cable patch panel.

Table 17: Pinout Details

Pin #	Crossover	Straight-through
1	Receive Tip	Transmit Tip
2	Receive Ring	Transmit Ring
3	—	—
4	Transmit Tip	Receive Tip
5	Transmit Ring	Receive Ring
6	—	—
7	—	—
8	—	—

Panel and Bracket

Table 18: Panel and Bracket Details

Panel	Bracket Description
PANEL-3G-COMBO-1	Single 12E1 + 4xDS3 patch panel for 3G CEM/IMSG IM (requires crossover cable)
PANEL-3G-COMBO-2	Double 12E1 + 4xDS3 patch panel for 3G CEM/IMSG IM (requires crossover cable)
PANEL-3G-COMBO-1S	Single 12E1 + 4xDS3 patch panel for 3G CEM/IMSG (requires a straight-through cable)
PANEL-3G-COMBO-2S	Double 12E1 + 4xDS3 patch panel for 3G CEM/IMSG IM (requires a straight-through cable)
P3G1-RCKMNT-19IN	EIA 19 inches mounting brackets for single 3G CEM/IMSG IM patch panel
P3G1-RCKMNT-ETSI	ETSI 21 inches mounting brackets for single 3G CEM/IMSG IM patch panel
P3G1-RCKMNT-23IN	EIA 23 inches mounting brackets for single 3G CEM/IMSG IM patch panel
P3G2-RCKMNT-19IN	EIA 19 inches mounting brackets for double 3G CEM/IMSG IM patch panel
P3G2-RCKMNT-ETSI	ETSI 21 inches mounting brackets for double 3G CEM/IMSG IM patch panel
P3G2-RCKMNT-23IN	EIA 23 inches mounting brackets for double 3G CEM/IMSG IM patch panel

Connecting the Fan Tray Alarm Port

The fan tray includes an alarm port that maps to 4 dry contact alarm inputs.

The pins on the alarm port are passive signals and can be configured as Normally Open (an alarm generated when current is interrupted) or Normally Closed (an alarm is generated when a circuit is established) alarms. You can configure each alarm input as critical, major, or minor. An alarm triggers alarm LEDs and alarm messages. The relay contacts can be controlled through any appropriate third-party relay controller. The open/close configuration is an option controlled in IOS.

**Warning**

To comply with the Telcordia GR-1089 NEBS standard for electromagnetic compatibility and safety, connect the alarm ports only to intra-building or unexposed wiring or cable. The intrabuilding cable must be shielded and the shield must be grounded at both ends. The intra-building port(s) of the equipment or subassembly must not be metalically connected to interfaces that connect to the OSP or its wiring. These interfaces are designed for use as intra-building interfaces only (Type 2 or Type 4 ports as described in GR-1089-CORE) and require isolation from the exposed OSP cabling. The addition of Primary Protectors is not sufficient protection in order to connect these interfaces metalically to OSP wiring.

Only Pins 1, 2, 4, 6, and 8 are available for customer use. The remaining pins are for Cisco manufacturing test, and should not be connected. Use a shielded cable for connection to this port for EMC protection. See [Troubleshooting](#) for a summary of the pinouts on the alarm port .

Procedure

-
- Step 1** Attach an RJ45 cable to the alarm port.
- Step 2** Attach the other end of the RJ45 cable to the relay controller.
-

Connector and Cable Specifications

For more information on cable specifications and pinouts, see [Troubleshooting](#).



CHAPTER 4

Cisco NCS 4206 Initial Configuration

This chapter guides you through a basic configuration, which is sufficient for you to access your network. Complex configuration procedures are beyond the scope of this publication and can be found in the modular configuration and modular command reference publications in the Cisco IOS software configuration documentation set that corresponds to the software release installed on your Cisco hardware.

To configure the Cisco NCS 4206 from a console, you need to connect a terminal to the console port.

- [Checking Conditions Prior to System Startup](#) , on page 143
- [Powering Up the Cisco NCS 4206](#), on page 144
- [Configuring the Cisco NCS 4206 at Startup](#), on page 145
- [Safely Powering Off the Cisco NCS 4206](#), on page 148

Checking Conditions Prior to System Startup

Ensure that the following conditions are addressed before starting up the :

- The Route Switch Processor (RSP) is installed.
- The optional Gigabit Ethernet Management port cable is installed.
- The chassis is securely mounted and grounded.
- The power and interface cables are connected.
- Your PC with terminal emulation program (hyperTerminal or equivalent) is connected to the console port and powered up.
- Your PC terminal emulation program is configured for 9600 baud, 8 data bits, 1 stop-bit, no parity, and flow control is set to none.
- You have selected passwords for access control.
- Captive installation screws are tight on all removable components.
- The console terminal is turned on.
- You have determined the IP addresses for the Ethernet and serial interfaces.
- Empty card slots or card bays are filled with card blanks. This ensures proper air flow through the chassis and electromagnetic compatibility (EMC).

Powering Up the Cisco NCS 4206

Make certain that all card slots and compartments are closed off. Install blank faceplates on any empty slots. Always have power supply slots filled. If you leave a power supply slot uncovered, then you risk exposure to hazardous voltages on the power pins on the midplane.



Warning Blank faceplates and cover panels serve three important functions: they prevent exposure to hazardous voltages and currents inside the chassis; they contain electromagnetic interference (EMI) that might disrupt other equipment; and they direct the flow of cooling air through the chassis. Do not operate the system unless all cards, faceplates, front covers, and rear covers are in place. Statement 1029

After installing your Cisco NCS 4206 and connecting cables, start the and follow these steps:

Procedure

Step 1 Activate the DC power supply using the steps described in [Activating the DC Power Supply](#).

Caution Do not press any keys on the keyboard until the messages stop and the SYS PWR LED is solid green. Any keys pressed during this time are interpreted as the first command typed when the messages stop, which might cause the chassis to power off and start over. It takes a few minutes for the messages to stop.

Step 2 Observe the initialization process. When the system boot is complete (the process takes a few seconds), the Cisco NCS 4206 RSP begins to initialize.

During the boot process, observe the system LEDs. The LEDs on the shared port adapter go on and off in an irregular sequence. Once the chassis has booted, the green STATUS LED comes on and stays on.

Verifying the Front Panel LEDs

The front-panel indicator LEDs provide power, activity, and status information useful during bootup. For more detailed information about the LEDs, see [Troubleshooting](#).

Verifying the Hardware Configuration

To display and verify the hardware features, enter the following commands:

- **show version**—Displays the system hardware version; the installed software version; the names and sources of configuration files; the boot images; and the amount of installed DRAM, NVRAM, and flash memory.
- **show diag slot**—Displays the IDPROM information for the assemblies in the chassis.

Checking Hardware and Software Compatibility

To check the minimum software requirements of the Cisco IOS software with the hardware installed on your Cisco NCS 4206, Cisco maintains the Software Advisor tool on Cisco.com. The tool provides the minimum Cisco IOS requirements for individual hardware modules and components.



Note To access this tool, you must have a Cisco.com login account.

To access the Software Advisor, click **Login** at Cisco.com, type **Software Advisor** in the search box, and click **Go**. Click the link for the Software Advisor Tool.

Choose a product family or enter a specific product number to search for the minimum supported software needed for your hardware.

Configuring the Cisco NCS 4206 at Startup

This section explains how to create a basic running configuration for your Cisco NCS 4206.



Note You need to acquire the correct network addresses from your system administrator or consult your network plan to determine correct addresses before you can complete the chassis configuration.

Before continuing the configuration process, check the current state of the chassis by entering the **show version** command. The **show version** command displays the release of Cisco IOS software that is available on the chassis.

For information on modifying the configuration after you create it, see the Cisco IOS configuration and command reference guides.

To configure a Cisco NCS 4206 from the console, you must connect a terminal or terminal server to the console port on the Cisco NCS 4206 RSP. To configure the Cisco NCS 4206 using the management Ethernet port, you must have the chassis's IP address available.

Using the Console Interface

To access the command line interface using the console, follow these steps:

Procedure

Step 1 Your system is booting and if you answer No, at the prompt:

Example:

```
--- System Configuration Dialog ---
Would you like to enter the initial configuration dialog? [yes/no]: no
```

Step 2 Press **Return** to enter user EXEC mode. The following prompt appears:

```
>
```

Step 3 From user EXEC mode, enter the enable command as shown in the following example:

```
> enable
```

Step 4 At the password prompt, enter your system password. If an enable password has not been set on your system, this step may be skipped. The following example shows entry of the password called *enablepass* :

```
Password: enablepass
```

Step 5 When your enable password is accepted, the privileged EXEC mode prompt appears: #

Step 6 You now have access to the CLI in privileged EXEC mode and you can enter the necessary commands to complete your desired tasks. To exit the console session, enter the quit command as shown in the following example:

Example:

```
# quit
```

Configuring Global Parameters

When you first start the setup program, you must configure the global parameters. These parameters are used for controlling system-wide settings. Perform the following steps to enter the global parameters:

Procedure

Step 1 Connect a console terminal to the console port, and then boot the chassis.

Note This is only an example of the output display; prompts may vary.

When you see this information, you have successfully booted your chassis:

Example:

```
Restricted Rights Legend
```

```
Use, duplication, or disclosure by the Government is
subject to restrictions as set forth in subparagraph
(c) of the Commercial Computer Software - Restricted
Rights clause at FAR sec. 52.227-19 and subparagraph
(c) (1) (ii) of the Rights in Technical Data and Computer
Software clause at DFARS sec. 252.227-7013.
```

```
    cisco Systems, Inc.
    170 West Tasman Drive
    San Jose, California 95134-1706
```

```
.
.
.
```

```
--- System Configuration Dialog ---
```

```
Would you like to enter the initial configuration dialog? [yes/no]: yes
```

```
Press RETURN to get started!
```

Step 2 The first sections of the configuration script appear only at an initial system startup. On subsequent uses of the setup facility, the script begins with a System Configuration Dialog as shown below: When asked if you would like to enter the initial configuration dialog, enter yes.

Example:

```
Would you like to enter the initial configuration dialog? [yes/no] yes
At any point you may enter a question mark '?' for help.
Use ctrl-c to abort configuration dialog at any prompt.
Default settings are in square brackets '['].
Basic management setup configures only enough connectivity for management of the system, extended
setup will ask you to configure each interface on the system.
```

Basic management setup configures enough connectivity for managing the system; extended setup will ask you to configure each interface on the system. For detailed information about setting global parameters, refer to the *Cisco NCS 4206 Software Configuration Guide*.

Checking the Running Configuration Settings

To check the value of the settings you have entered, enter the **show running-config** command at the # prompt:

```
# show running-config
```

To review changes you make to the configuration, use the EXEC mode **show startup-config** command to see the changes and copy run-start stored in NVRAM.

The ROMMON variable is set from factory to boot the IOS as “BOOT=bootflash:Image/packages.conf”. However, the boot command is not pre-configured.

As the boot command is not configured, the chassis boots to ROMMON mode after the first power cycle, and the following message is displayed:

```
no valid BOOT image found
Final autoboot attempt from default boot device...
Located tracelogs.030
Image size 6181 inode num 13, bks cnt 2 blk size 8*512
Boot image size = 6181 (0x1825) bytes
Unknown image structure
boot: cannot determine first file name on device "bootflash:/"
rommon1>.
```

To avoid the chassis booting into ROMMON state, it's highly recommended that you set the boot command prior to the first reload.

```
(config)# boot system flash bootflash://Image/ncs4206rsp-x.x.x.x.-ext.bin
```

Saving the Running Configuration to NVRAM

To store the configuration or changes to your startup configuration in NVRAM, enter the **copy running-config startup-config** command at the # prompt:

```
# copy running-config startup-config
```

Using this command saves the configuration settings that you created in the chassis using configuration mode and the setup facility. If you fail to do this, your configuration will be lost the next time you reload the chassis.

Safely Powering Off the Cisco NCS 4206

This section explains how to shut down the Cisco NCS 4206. It is recommended that before turning off all power to the chassis, you issue the **reload** command. This insures that the operating system cleans up all the file systems. Once the reload operation is complete, then the Cisco NCS 4206 can be powered off safely.

To remove power from the Cisco NCS 4206 safely, follow this procedure and see the examples:

Procedure

Step 1 Slip on the ESD-preventive wrist strap that was included in the accessory kit.

Step 2 Enter the **reload** command.

Step 3 Confirm the reload command.

Example:

```
Rmcp-6ru-1#reload
Proceed with reload? [confirm]
Aug 17 00:06:47.051 R0/0: %PMAN-5-EXITACTION: Process manager is exiting: prs exit with reload chassis
code
```

Step 4 After confirming the reload command, wait until the system bootstrap message displays before powering off the system.

Step 5 Remove any power cables from the Cisco NCS 4206.

- a) For power supplies with a circuit breaker switch, position the switch to the Off (O) position.
- b) For power supplies with a Standby switch, place the Standby switch in the Standby position.

Note After powering off the , wait a minimum of 30 seconds before powering it on again.



CHAPTER 5

Troubleshooting

This chapter provides information for troubleshooting problems on the Cisco NCS 4206.

- [Pinouts, on page 149](#)
- [LED Summary, on page 162](#)

Pinouts

The following sections describe the pinouts for the Cisco NCS 4206 interfaces:

BITS Port Pinout

The table below summarizes the BITS port pinout of the Front Panel “Building Integrated Timing Supply” RJ48 port.

Table 19: BITS Port Pinout

Pin	Signal Name	Direction	Description
1	RX Ring	Input	Receive Ring
2	RX Tip	Input	Receive Tip
3			Not used
4	TX Ring	Output	TX Ring
5	TX Tip	Output	TX Tip
6			Not used
7			Not used
8			Not used

Wire Wrap Adapter Pinouts

Table 20: Wire Wrap Adapter Pinouts

Wire Wrap Pin Numbers	Signals
1	RX_RING
2	RX_TIP
3	GND
4	GND
5	TX_RING
6	TX_TIP

GPS Port Pinout

The platform is capable of receiving or sourcing GPS signals of 1 PPS & 10 MHz. These interfaces are provided by two mini-coax 50-Ohm, 1.0/2.3 DIN series connector on the front panel. Similarly there are two mini-coax 50-Ohm connectors provided in the front panel to output this 1PPS and 10MHz.

The table below summarizes the GPS port pinouts.

Table 21: GPS Port Pinout for RSP

	10 Mhz (input and output)	1PPS (input and output)
Waveform	Input—Sine wave Output—Sine and Square wave	Input—Pulse shape Output—Pulse shape
Amplitude	Input— > 1.7 volt p-p(+8 to +10 dBm) Output— > 2.4 volts TTL compatible	Input— > 2.4 volts TTL compatible Output— > 2.4 volts TTL compatible
Impedance	50 ohms	50 ohms
Pulse Width	50% duty cycle	26 microseconds
Rise Time	Input—AC coupled Output—5 nanoseconds	40 nanoseconds

Time of Day Port Pinout

The table below summarizes the TOD pinout for NCS420X-RSP modules.



Note This port requires the use of SHIELDED cable for GR-1089-core “Intra-Bldg lightning surge” protection. RS422 interface is per industry standard EIA-422 /RS422 specification.

Table 22: RJ48 IPPS/ToD Port Pinout

Pin	Signal Name	Direction	Description
1	RESERVED	Output or Input	V.11 Cable Corporation
2	RESERVED	Output or Input	
3	1PPS_N	Input	1PPS RS422 signal
4	GND		
5			
6	1PPS_P	Input	1PPS RS422 signal
7	TOD_N	Output or Input	Time of Day R422 output or input signal
8	TOD_P	Output or Input	Time of Day R422 output or input signal

Alarm Port Pinout

The table below summarizes the external alarm input pinout.

Table 23: External Alarm Input Pinout

Pin	Signal Name	Description
1	ALARM0_IN	Alarm input 0
2	ALARM1_IN	Alarm input 1
3		No connect
4	ALARM2_IN	Alarm input 2
5	ALARM3_IN	Alarm input 3
6		No connect
7		No connect

Pin	Signal Name	Description
8	COMMON	Alarm common

Console/Aux RJ45 RS232 Serial Port Pinout

The table below summarizes the console/aux RJ45 RS232 serial port pinout.

Table 24: Console/Aux RJ45 RS232 serial port

Pin	Signal Name	Direction	Description
1	RTS	Output	Request to send
2	DTR	Output	Data Terminal Ready (always On).
3	TXD	Output	Transmit data
4	RI		Ring Indicator
5	GND		
6	RXD	Input	Receive data
7	DSR/DCD	Input	Data set ready/Data Carrier detect
8	CTS	Input	Clear to send

8 T1/E1 Interface Module RJ48C Port Pinnouts

Table 25: RJ48C Connector Pin-out for 8 T/E1 Interface Module

Pin	Signal	Direction	Description
1	RX_TIP	Input	Receive Tip
2	RX_RING	Output	Receive Ring
3	—	—	Not Connected
4	TX_TIP	Input	Receive Tip
5	TX_RING	Output	Receive Ring
6	—	—	Not Connected
7	—	—	Not Connected
8	—	—	Not Connected

T1/E1 Port Pinout

RJ48 T1/E1 Port Pinouts

The figure below shows the RJ48 connector wiring for the T1/E1 cable for the interface module. The table shows the pinout configuration for the RJ4C connectors for both the shielded and unshielded cables for either T1 or E1.

Figure 115: RJ48 Connector Wiring

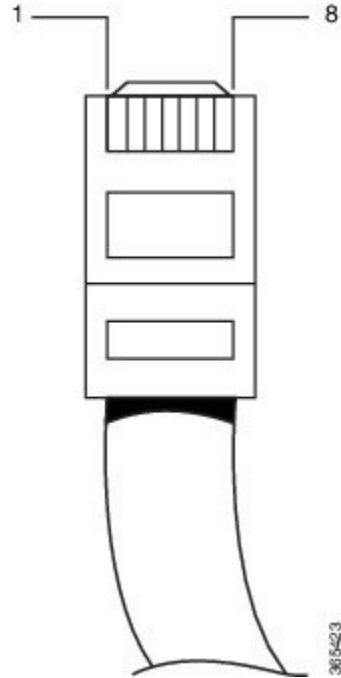

The table below summarizes the RJ48 port pinout.

Table 26: RJ48 Port Pinouts

Shielded	Unshielded		
Pin	Description	Pin	Description
1	Receive Ring	1	Receive Ring
2	Receive Tip	2	Receive Tip
3	Receive Shield	3	
4	Transmit Ring	4	Transmit Ring
5	Transmit Tip	5	Transmit Tip
6	Transmit Shield	6	
7	Not Used	7	

Shielded	Unshielded		
8	Not Used	8	

The table below summarizes the RJ45 port pinout.

Table 27: RJ45 Port Pinout

Pin	Signal Name	Direction	Description
1	1PPS_P	Output or Input	1PPS RS422 signal
2	1PPS_N	Output or Input	1PPS RS422 signal
3	RESERVED	Output	Do NOT connect
4	GND		
5	GND		Time of Day character
6	RESERVED	Input	Do NOT connect
7	TOD_P	Output or Input	Time of Day character
8	TOD_N	Output or Input	Time of Day character

AMP64 Pinouts

Table 28: Port 0-23 RX

Pin Number	Signal Name	Pin	Signal
1	RX Ring Port 0	33	RX Tip Port 0
2	RX Ring Port 1	34	RX Tip Port 1
3	RX Ring Port 2	35	RX Tip Port 2
4	RX Ring Port 3	36	RX Tip Port 3
5	RX Ring Port 4	37	RX Tip Port 4
6	RX Ring Port 5	38	RX Tip Port 5
7	RX Ring Port 6	39	RX Tip Port 6
8	RX Ring Port 7	40	RX Tip Port 7
9	RX Ring Port 8	41	RX Tip Port 8
10	RX Ring Port 9	42	RX Tip Port 9
11	RX Ring Port 10	43	RX Tip Port 10

Pin Number	Signal Name	Pin	Signal
12	RX Ring Port 11	44	RX Tip Port 11
13	RX Ring Port 12	45	RX Tip Port 12
14	RX Ring Port 13	46	RX Tip Port 13
15	RX Ring Port 14	47	RX Tip Port 14
16	RX Ring Port 15	48	RX Tip Port 15
17	RX Ring Port 16	49	RX Tip Port 16
18	RX Ring Port 17	50	RX Tip Port 17
19	RX Ring Port 18	51	RX Tip Port 18
20	RX Ring Port 19	52	RX Tip Port 19
21	RX Ring Port 20	53	RX Tip Port 20
22	RX Ring Port 21	54	RX Tip Port 21
23	RX Ring Port 22	55	RX Tip Port 22
24	RX Ring Port 23	56	RX Tip Port 23
25	Open	57	Open
26	Open	58	Open
27	Open	59	Open
28	Open	60	Open
29	Open	61	Open
30	Open	62	Open
31	Open	63	Open
32	Open	64	Open

Table 29: Port 24-47 RX

Pin Number	Signal Name	Pin	Signal
1	RX Ring Port 24	33	RX Tip Port 24
2	RX Ring Port 25	34	RX Tip Port 25
3	RX Ring Port 26	35	RX Tip Port 26
4	RX Ring Port 27	36	RX Tip Port 27

Pin Number	Signal Name	Pin	Signal
5	RX Ring Port 28	37	RX Tip Port 28
6	RX Ring Port 29	38	RX Tip Port 29
7	RX Ring Port 30	39	RX Tip Port 30
8	RX Ring Port 31	40	RX Tip Port 31
9	RX Ring Port 32	41	RX Tip Port 32
10	RX Ring Port 33	42	RX Tip Port 33
11	RX Ring Port 34	43	RX Tip Port 34
12	RX Ring Port 35	44	RX Tip Port 35
13	RX Ring Port 36	45	RX Tip Port 36
14	RX Ring Port 37	46	RX Tip Port 37
15	RX Ring Port 38	47	RX Tip Port 38
16	RX Ring Port 39	48	RX Tip Port 39
17	RX Ring Port 40	49	RX Tip Port 40
18	RX Ring Port 41	50	RX Tip Port 41
19	RX Ring Port 42	51	RX Tip Port 42
20	RX Ring Port 43	52	RX Tip Port 43
21	RX Ring Port 44	53	RX Tip Port 44
22	RX Ring Port 45	54	RX Tip Port 45
23	RX Ring Port 46	55	RX Tip Port 46
24	RX Ring Port 47	56	RX Tip Port 47
25	Open	57	Open
26	Open	58	Open
27	Open	59	Open
28	Open	60	Open
29	Open	61	Open
30	Open	62	Open
31	Open	63	Open
32	Open	64	Open

Table 30: Port 0-23 TX

Pin Number	Signal Name	Pin	Signal
1	TX Ring Port 0	33	TX Tip Port 0
2	TX Ring Port 1	34	TX Tip Port 1
3	TX Ring Port 2	35	TX Tip Port 2
4	TX Ring Port 3	36	TX Tip Port 3
5	TX Ring Port 4	37	TX Tip Port 4
6	TX Ring Port 5	38	TX Tip Port 5
7	TX Ring Port 6	39	TX Tip Port 6
8	TX Ring Port 7	40	TX Tip Port 7
9	TX Ring Port 8	41	TX Tip Port 8
10	TX Ring Port 9	42	TX Tip Port 9
11	TX Ring Port 10	43	TX Tip Port 10
12	TX Ring Port 11	44	TX Tip Port 11
13	TX Ring Port 12	45	TX Tip Port 12
14	TX Ring Port 13	46	TX Tip Port 13
15	TX Ring Port 14	47	TX Tip Port 14
16	TX Ring Port 15	48	TX Tip Port 15
17	TX Ring Port 16	49	TX Tip Port 16
18	TX Ring Port 17	50	TX Tip Port 17
19	TX Ring Port 18	51	TX Tip Port 18
20	TX Ring Port 19	52	TX Tip Port 19
21	TX Ring Port 20	53	TX Tip Port 20
22	TX Ring Port 21	54	TX Tip Port 21
23	TX Ring Port 22	55	TX Tip Port 22
24	TX Ring Port 23	56	TX Tip Port 23
25	Open	57	Open
26	Open	58	Open
27	Open	59	Open

Pin Number	Signal Name	Pin	Signal
28	Open	60	Open
29	Open	61	Open
30	Open	62	Open
31	Open	63	Open
32	Open	64	Open

Table 31: Port 24-47 TX

Pin Number	Signal Name	Pin	Signal
1	TX Ring Port 24	33	TX Tip Port 24
2	TX Ring Port 25	34	TX Tip Port 25
3	TX Ring Port 26	35	TX Tip Port 26
4	TX Ring Port 27	36	TX Tip Port 27
5	TX Ring Port 28	37	TX Tip Port 28
6	TX Ring Port 29	38	TX Tip Port 29
7	TX Ring Port 30	39	TX Tip Port 30
8	TX Ring Port 31	40	TX Tip Port 31
9	TX Ring Port 32	41	TX Tip Port 32
10	TX Ring Port 33	42	TX Tip Port 33
11	TX Ring Port 34	43	TX Tip Port 34
12	TX Ring Port 35	44	TX Tip Port 35
13	TX Ring Port 36	45	TX Tip Port 36
14	TX Ring Port 37	46	TX Tip Port 37
15	TX Ring Port 38	47	TX Tip Port 38
16	TX Ring Port 39	48	TX Tip Port 39
17	TX Ring Port 40	49	TX Tip Port 40
18	TX Ring Port 41	50	TX Tip Port 41
19	TX Ring Port 42	51	TX Tip Port 42
20	TX Ring Port 43	52	TX Tip Port 43

Pin Number	Signal Name	Pin	Signal
21	TX Ring Port 44	53	TX Tip Port 44
22	TX Ring Port 45	54	TX Tip Port 45
23	TX Ring Port 46	55	TX Tip Port 46
24	TX Ring Port 47	56	TX Tip Port 47
25	Open	57	Open
26	Open	58	Open
27	Open	59	Open
28	Open	60	Open
29	Open	61	Open
30	Open	62	Open
31	Open	63	Open
32	Open	64	Open

Management Ethernet Port Pinout

A single management copper ENET port supporting 10/100/1000Base-T operation exists on each RSP. There is no direct access to the CPU of the other RSP. It uses a standard RJ45 jack.



Note This is not a data plane port.

The table below summarizes the Management Ethernet port pinout.

Table 32: Management Ethernet Port Pinout

Pin	Signal Name	Description
1	TRP0+	
2	TRP0-	
3	TRP1+	
4	TRP1-	
5	TRP2+	
6	TRP2-	

Pn	Signal Name	Description
7	TRP3+	
8	TRP3-	

USB Console Port Pinout

Two individual Type-A USB connector are used for USB console and USB mass storage. One single USB 2.0 Type-A receptacle is provided on the RSP front panel for providing console access to ROMMON, IOS-XE and diagnostics. It operates as a USB peripheral only for connection to an external host PC. This requires the use of a Type-A to Type-A connector instead of a standard USB cable.



Note The use of the USB console is mutually exclusive with the RS232 console/Aux port. While a USB cable is inserted, access is automatically switched to this port.

The other single USB 2.0 Type-A receptacle is provided on the RSP front panel for inserting external USB mass storage devices such as standard USB flash drives. It is used to load images, store configurations, write logs, etc. It supports operation up to 12Mbps

The table below summarizes the USB console port pinout.

Table 33: Single USB Console Port

Pn	Signal Name	Direction	Description
A1	Vcc		+5VDC (500mA)
A2	D-		Data -
A3	D+		Data +
A4	Gnd		Ground



Note The USB Console port +5VDC is input and operates as an USB peripheral device.

USB Flash/MEM Port Pinout

The table below summarizes the USB flash/MEM port pinout.

Table 34: Single USB Flash/MEM Port

Pin	Signal Name	Direction	Description
A1	Vcc		+5VDC (500mA)
A2	D-		Data -
A3	D+		Data +
A4	Gnd		Ground



Note USB TYPE-A receptacle used.



Note The USB flash/MEM port +5VDC is output. We provide power for USB flash/MEM, and it operates as a USB host device.

Fiber-Optic Specifications

The specification for optical fiber transmission defines two types of fiber: single-mode and multimode. Within the single-mode category, three transmission types are defined: short reach, intermediate reach, and long reach. Within the multimode category, only short reach is available. For information about optical SFP modules, see the documentation for the SFP module at

http://www.cisco.com/en/US/partner/products/hw/modules/ps5455/prod_installation_guides_list.html.

Cabling Guidelines

The guidelines are recommended during the installation of fiber cables:

- Avoid the following actions that can stress the cable:
 - Pulling or stretching beyond the specified pulling load rate
 - Bending it beyond the specified bend radius
 - Creating tension in the suspension runs
- Do not touch the fiber tips of fiber cables.
- Use single mode or multi-mode optical fiber cables as per the optical transceiver requirement.
- Use fiber cleaner to clean the fiber tip as well as transceiver before inserting the fiber cable into the optical transceiver during installation.
- To avoid excessive bending of fiber cable and efficient routing of cables, cable guides or cable brackets are recommended to be used with the chassis.

LED Summary

The following sections describe the meanings of the LEDs on the Cisco NCS 4206.

RSP LEDs

The table below summarizes the RSP LEDs for the supported RSP modules.



Note A major alarm condition indicates the failure of a single fan in the fan tray; a critical alarm indicates the failure of multiple fans. In the event that a single fan fails, the Cisco NCS 4206 software adjusts the fan speed to prevent excessive heat within the chassis.

NCS420X-RSP LED

Table 35: RSP LEDs

LED	Color/State	Description (two LEDs for each port)
Power (PWR)	Off	Disabled/no power to RSP
	Green	Power rails on RSP in range
Status (STAT)	Off	Disabled/power down
	Red	Failure to boot (lit at reset)
	Yellow	Rommon booted
	Green	IOS booted and running
Active (ACT)	Off	Not available
	Yellow	Standby (indicates standby RSP)
	Green	Active (indicates active RSP)
Management port (MGMT)	Off	No connection
	Green	Connected with no activity
	Flashing green	Connected with activity
Sync status (SYNC)	Off	Not enabled
	Yellow	Free run
	Flashing yellow	Holdover
	Green	Locked to source

LED	Color/State	Description (two LEDs for each port)
USB flash (MEM)	Flashing green	USB activity
BITS	Off	Out of service/not configured
	Amber	Fault or loop condition
	Green	In frame/working properly

NCS420X-RSP LED Fault Condition

The PWR and STAT LEDs are available on the front panel. These LEDs provide power on the board (PWR) and overall router health (STAT) status. During power up state, these LEDs provide booting status and report errors.



Note The digital code signing functionality validates the integrity and authenticity of the ROMMON image before booting it.

Table 36: ASR900-RSP2 and ASR900-RSP3 LED

PWR LED State	STAT LED State	Indication	Comment
Light Green	Red	Power is OK and the field-programmable gate array (FPGA) is nfigured successfully, but FPGA image validation failed.	Image validation failed. System is in hung state.
Flashing Light Green and Green alternatively	Off	FPGA configured and core validated successfully. FPGA image passed the control to micro-loader to boot ROMMON.	System is up with ROMMON. Both the FPGA image is validated successfully, but the booted ROMMON (primary or secondary) is undetermined.
	Amber	The digital code signing functionality reported upgrade FPGA image validation error and is continuing with the FPGA image.	System is up with ROMMON. FPGA image is validated successfully, but the booted ROMMON (primary or secondary) is undetermined.
	Red	The digital code signing functionality reported failure in the ROMMON image validation.	FPGA is up but both primary and secondary ROMMON failed. System is in hung state.
Green	Off	IOS is successfully booted	IOS writes into FPGA register to indicate that it has booted, FPGA stops flashing PWR LED and turns Green. Software now controls the STAT LED.

Interface Module LEDs

The table below summarizes the interface module LEDs. This LED summary applies to the following interface modules:

- SFP Gigabit Ethernet Interface Module
- 8x1 Gigabit Ethernet SFP + 1x10 Gigabit Ethernet SFP+ Interface Module
- 8/16-port 1 Gigabit Ethernet (SFP/SFP) + 1-port 10 Gigabit Ethernet (SFP+) / 2-port 1 Gigabit Ethernet (CSFP) Interface Module

The Status LED is Amber for the 10 Gigabit Ethernet ports when operating in WAN mode for the following IMs:

- 8x1 Gigabit Ethernet SFP + 1x10 Gigabit Ethernet SFP+ Interface Module

The 1-port 100 Gigabit Ethernet (QSFP) Interface Module (2X100GE) does not support the Speed LED.

Table 37: Interface Module LEDs

LED	Color/State	Description
Power (PWR)	Off	Disabled/no power to IM
	Green	Enabled and power rails on IM in range
Status (STAT)	Off	Disabled/power-down
	Red	Failure (on at reset)
	Flashing Red	Booting (if local CPU)
	Green	Operational
Link status (L)	Off	Inactive or no connection
	Amber	Fault/loop condition
	Green	Ok with activity or no activity
Speed (S)	Off	Inactive port status
	Green	Activity or no activity

OC-192 Interface Module + 8-Port Low Rate Interface Module LEDs

The following table summarizes the LEDs for the OC-192 interface module + 8-port Low Rate interface module.

Table 38: Interface Module LEDs

LED	Color or State	Description
Power (PWR)	Green	All power rails are within specification
	Red	Disabled
	Off	No power to IM
Status (STAT)	Green	Operational
	Red	Failure
	Off	Disabled
SFP Link (left LED)	Green	Link is up
	Yellow	Fault/Error/Alarm
	Off	Disabled
SFP speed mode (right LED)	Yellow	SONET/SDH
	Off	Disabled
10G SFP+ Link (left LED)	Green	Link is up
	Yellow	Fault/Error/Alarm
	Off	Disabled
10G SFP+ Speed mode (right LED)	Yellow	SONET/SDH
	Off	Disabled

48 T1/E1 and 48 T3/E3 Interface Module LEDs

The table below summarizes the LEDs for the 48 T1/E1 and 48 T3/E3 interface module.

Table 39: 48 T1/E1 and 48 T3/E3 Interface Module LEDs

LED	Color/State	Meaning (Default=off)
Power (PWR)	Green	All power rails are within spec
	Red	Disabled
	Off	No power to Interface Module
Operating Status (STATUS)	Green	Operational
	Red	Failure
	Off	Disabled or power-down

LED	Color/State	Meaning (Default=off)
Port Status (PORT)	Green	All ports are UP
	Amber	All least one port is down
	Off	All ports are disabled or shut down
Activity Status (ACT)	Green	Interface Module is Active or Standby
	Off	Interface Module is disabled or shut down

8-port 10 Gigabit Ethernet Interface Module LEDs

The table below summarizes the 8-port 10 Gigabit ethernet interface module.

Table 40: 8-port 10 Gigabit ethernet Interface Module LEDs

LED	Color/State	Description
Power (PWR)	Green	All power rails are within specification
	Red	Disabled
	Off	No power to Interface Module
Operating Status (STAT)	Red	Failure
	Off	Disabled or Power-Down
	Green	Operational
10G SFP+ Link (Left LED)	Off	Disabled or No link
	Yellow	Fault or Error
	Green	Link with no activity
	Green	Link with activity
10G SFP+ Speed/Mode (Right LED)	Yellow	10Gbps WAN
	Green	10 Gbps LAN
	Alternating Yellow or Green	10 Gbps OTN
	Off	Disabled

1-port 100 Gigabit Ethernet Interface Module LEDs

The table below summarizes the 1-port 100 Gigabit ethernet interface module.

Table 41: 1-port 100 Gigabit Ethernet Interface Module LEDs

LED	Color/State	Description
Power (PWR)	Green	All power rails are within specification
	Red	Disabled
	Off	No power to Interface Module
Operating Status (STAT)	Red	Failure
	Off	Disabled or Power-Down
	Green	Operational
100G CPAK Link LED	Off	Disabled or No link
	Yellow	Fault or Error
	Green	Link with activity
	Green	Link with no activity

2-port 40 Gigabit Ethernet Interface Module LEDs

The table below summarizes the 2-port 40 Gigabit ethernet interface module.

Table 42: 2-port 40 Gigabit Ethernet Interface Module LEDs

LED	Color/State	Description
Power (PWR)	Green	All power rails are within spec
	Red	Disabled
	Off	No power to Interface Module
Operating Status (STAT)	Red	Failure
	Off	Disabled or Power-Down
	Green	Operational
40G QSFP+ Link LED	Off	Disabled or No link
	Yellow	Fault or Error
	Green	Link with activity
	Green	Link with no activity

Power Supply LEDs

The table below summarizes the power supply LEDs for both the AC and DC power supplies.

Table 43: A900-PWR-1200-D DC Power Supply LEDs

LED	Color/State	Description
Input OK	Off	No Input Voltage
	Amber	Input voltage out of range
	Green	Input voltage within acceptable operating range
Output Fail	Off	Disabled/Forced Shut down/No input power
	Red	Power supply fault (internal failure such as over temperature)
	Green	Operational
	Blinking Red	Output ORING FET Failed

Fan Tray LEDs

The table below summarizes the fan tray LEDs.

Table 44: Fan Tray LEDs

LED	Color/State	Description
Status (TEMP)	Off	Disabled/power down
	Amber	Over temperature
	Green	OK
Fan (FAN)	Green	Fan rotation in range
	Amber	Single fan fault
	Red	Two or more fan faults
Minor (MIN)	Off	No minor alarm
	Amber	Minor alarm
Major (MAJ)	Off	No major alarm
	Red	Major alarm
Critical (CRIT)	Off	No critical alarm
	Red	Critical alarm (defaults to ON upon RSP reset)

Alarm Conditions

The table below summarizes the meaning of alarm conditions on the Cisco NCS 4206.

Table 45: Alarm Condition Summary

Alarm Type	Alarm Meaning
Critical	RSP OIR
	Power supply OIR
	Port in down state
	Environmental sensor threshold exceeded (voltage, temperature)
	IM OIR
	IM crash
Major	Standby RSP in ROMmon mode
	RSP removed
	RSP failure
Info	Port administratively shut down

Manufactures

The table below lists the manufacturers for equipment used with the Cisco NCS 4206.

Table 47: Manufactures

Manufacturer	Web Site or Phone Number	Products/Model
Burndy	http://www.burndy.com	Lugs

THE SPECIFICATIONS AND INFORMATION REGARDING THE PRODUCTS IN THIS MANUAL ARE SUBJECT TO CHANGE WITHOUT NOTICE. ALL STATEMENTS, INFORMATION, AND RECOMMENDATIONS IN THIS MANUAL ARE BELIEVED TO BE ACCURATE BUT ARE PRESENTED WITHOUT WARRANTY OF ANY KIND, EXPRESS OR IMPLIED. USERS MUST TAKE FULL RESPONSIBILITY FOR THEIR APPLICATION OF ANY PRODUCTS.

THE SOFTWARE LICENSE AND LIMITED WARRANTY FOR THE ACCOMPANYING PRODUCT ARE SET FORTH IN THE INFORMATION PACKET THAT SHIPPED WITH THE PRODUCT AND ARE INCORPORATED HEREIN BY THIS REFERENCE. IF YOU ARE UNABLE TO LOCATE THE SOFTWARE LICENSE OR LIMITED WARRANTY, CONTACT YOUR CISCO REPRESENTATIVE FOR A COPY.

The Cisco implementation of TCP header compression is an adaptation of a program developed by the University of California, Berkeley (UCB) as part of UCB's public domain version of the UNIX operating system. All rights reserved. Copyright © 1981, Regents of the University of California.

NOTWITHSTANDING ANY OTHER WARRANTY HEREIN, ALL DOCUMENT FILES AND SOFTWARE OF THESE SUPPLIERS ARE PROVIDED "AS IS" WITH ALL FAULTS. CISCO AND THE ABOVE-NAMED SUPPLIERS DISCLAIM ALL WARRANTIES, EXPRESSED OR IMPLIED, INCLUDING, WITHOUT LIMITATION, THOSE OF MERCHANTABILITY, FITNESS FOR A PARTICULAR PURPOSE AND NON-INFRINGEMENT OR ARISING FROM A COURSE OF DEALING, USAGE, OR TRADE PRACTICE.

IN NO EVENT SHALL CISCO OR ITS SUPPLIERS BE LIABLE FOR ANY INDIRECT, SPECIAL, CONSEQUENTIAL, OR INCIDENTAL DAMAGES, INCLUDING, WITHOUT LIMITATION, LOST PROFITS OR LOSS OR DAMAGE TO DATA ARISING OUT OF THE USE OR INABILITY TO USE THIS MANUAL, EVEN IF CISCO OR ITS SUPPLIERS HAVE BEEN ADVISED OF THE POSSIBILITY OF SUCH DAMAGES.

Any Internet Protocol (IP) addresses and phone numbers used in this document are not intended to be actual addresses and phone numbers. Any examples, command display output, network topology diagrams, and other figures included in the document are shown for illustrative purposes only. Any use of actual IP addresses or phone numbers in illustrative content is unintentional and coincidental.

All printed copies and duplicate soft copies of this document are considered uncontrolled. See the current online version for the latest version.

Cisco has more than 200 offices worldwide. Addresses and phone numbers are listed on the Cisco website at www.cisco.com/go/offices.

Cisco and the Cisco logo are trademarks or registered trademarks of Cisco and/or its affiliates in the U.S. and other countries. To view a list of Cisco trademarks, go to this URL: <https://www.cisco.com/c/en/us/about/legal/trademarks.html>. Third-party trademarks mentioned are the property of their respective owners. The use of the word partner does not imply a partnership relationship between Cisco and any other company. (1721R)

© 2016–2024 Cisco Systems, Inc. All rights reserved.

