



# **RS720-E9-RS8/ RS8-G**

## **2U Rackmount Server User Guide**



E14455  
First Edition  
August 2018

**Copyright © 2018 ASUSTeK COMPUTER INC. All Rights Reserved.**

No part of this manual, including the products and software described in it, may be reproduced, transmitted, transcribed, stored in a retrieval system, or translated into any language in any form or by any means, except documentation kept by the purchaser for backup purposes, without the express written permission of ASUSTeK COMPUTER INC. ("ASUS").

ASUS provides this manual "as is" without warranty of any kind, either express or implied, including but not limited to the implied warranties or conditions of merchantability or fitness for a particular purpose. In no event shall ASUS, its directors, officers, employees, or agents be liable for any indirect, special, incidental, or consequential damages (including damages for loss of profits, loss of business, loss of use or data, interruption of business and the like), even if ASUS has been advised of the possibility of such damages arising from any defect or error in this manual or product.

Specifications and information contained in this manual are furnished for informational use only, and are subject to change at any time without notice, and should not be construed as a commitment by ASUS. ASUS assumes no responsibility or liability for any errors or inaccuracies that may appear in this manual, including the products and software described in it.

Product warranty or service will not be extended if: (1) the product is repaired, modified or altered, unless such repair, modification or alteration is authorized in writing by ASUS; or (2) the serial number of the product is defaced or missing.

Products and corporate names appearing in this manual may or may not be registered trademarks or copyrights of their respective companies, and are used only for identification or explanation and to the owners' benefit, without intent to infringe.

# Contents

Safety information.....	viii
About this guide.....	ix

## Chapter 1: Product Introduction

1.1	System package contents.....	1-2
1.2	Serial number label.....	1-3
1.3	System specifications .....	1-4
1.4	Front panel features.....	1-7
1.5	Rear panel features.....	1-7
1.6	Internal features .....	1-9
1.7	LED information .....	1-12
1.7.1	Front panel LEDs .....	1-12
1.7.2	Storage device status LED.....	1-13
1.7.3	LAN (RJ-45) LEDs .....	1-13
1.7.4	Q-Code table.....	1-14

## Chapter 2: Hardware Information

2.1	Chassis cover.....	2-2
2.2	Central Processing Unit (CPU) .....	2-3
2.2.1	Installing the CPU and heatsink.....	2-3
2.3	System memory .....	2-6
2.3.1	Overview .....	2-6
2.3.2	Memory Configurations.....	2-7
2.3.3	Installing a DIMM on a single clip DIMM socket.....	2-9
2.3.4	Removing a DIMM from a single clip DIMM socket .....	2-9
2.4	Storage devices.....	2-10

# Contents

- 2.5 Expansion slot.....2-16**
  - 2.5.1 Installing an expansion card to riser card bracket 1..... 2-19
  - 2.5.2 Installing an expansion card to riser card bracket 2..... 2-21
  - 2.5.3 Installing an expansion card to riser card bracket 3  
(for RS720-E9-RS8 only) ..... 2-23
  - 2.5.4 Installing an expansion card to riser card bracket 4..... 2-25
  - 2.5.5 Installing GPU cards (for RS720-E9-RS8-G only) ..... 2-27
  - 2.5.6 Replacing GPU cards (for RS720-E9-RS8-G only)..... 2-33
  - 2.5.7 Installing an ASUS PIKE II card..... 2-37
  - 2.5.8 Installing an ASUS PCIE-NVME4-OCuLink card ..... 2-39
  - 2.5.9 Installing an ASUS PCIE-NVME2-OCuLink card  
(for RS720-E9-RS8 only) ..... 2-42
  - 2.5.10 Configuring an expansion card ..... 2-44
  - 2.5.11 Installing Mezzanine cards..... 2-45
  - 2.5.12 Installing M.2 (NGFF) cards..... 2-48
- 2.6 Cable connections .....2-50**
- 2.7 SATA/SAS backplane cabling.....2-51**
- 2.8 Removable/optional components.....2-54**
  - 2.8.1 System fans ..... 2-54
  - 2.8.2 Redundant power supply module..... 2-55

## Chapter 3: Installation Options

- 3.1 Tool-less Friction Rail Kit..... 3-2**
- 3.2 Installing the tool-less rack rail ..... 3-3**
  - For 1U devices ..... 3-3
  - For 2U devices ..... 3-3
- 3.3 Rail kit dimensions ..... 3-6**

## Chapter 4: Motherboard Information

- 4.1 Motherboard layout..... 4-2**
- 4.2 Jumpers ..... 4-4**
- 4.3 Internal LEDs ..... 4-10**
- 4.4 Internal connectors ..... 4-13**

# Contents

## Chapter 5: BIOS Setup

<b>5.1</b>	<b>Managing and updating your BIOS .....</b>	<b>5-2</b>
5.1.1	ASUS CrashFree BIOS 3 utility.....	5-2
5.1.2	ASUS EZ Flash Utility .....	5-3
5.1.3	BUPDATER utility .....	5-4
<b>5.2</b>	<b>BIOS setup program .....</b>	<b>5-6</b>
5.2.1	BIOS menu screen.....	5-7
5.2.2	Menu bar .....	5-7
5.2.3	Menu items.....	5-8
5.2.4	Submenu items .....	5-8
5.2.5	Navigation keys.....	5-8
5.2.6	General help.....	5-8
5.2.7	Configuration fields .....	5-8
5.2.8	Pop-up window.....	5-8
5.2.9	Scroll bar.....	5-8
<b>5.3</b>	<b>Main menu .....</b>	<b>5-9</b>
5.3.1	System Date [Day xx/xx/xxxx].....	5-9
5.3.2	System Time [xx:xx:xx] .....	5-9
<b>5.4</b>	<b>Advanced menu .....</b>	<b>5-10</b>
5.4.1	Trusted Computing.....	5-11
5.4.2	ACPI Settings.....	5-11
5.4.3	Super IO Configuration .....	5-12
5.4.4	Onboard LAN I350 IO Configuration .....	5-13
5.4.5	Serial Port Console Redirection .....	5-14
5.4.6	APM .....	5-17
5.4.7	PCI Subsystem Settings .....	5-18
5.4.8	Network Stack Configuration.....	5-19
5.4.9	CSM Configuration.....	5-20
5.4.10	NVMe Configuration.....	5-21
5.4.11	USB Configuration .....	5-21
5.4.12	iSCSI Configuration.....	5-22
5.4.13	Intel(R) RSTe RAID Controller.....	5-22

# Contents

- 5.5 Platform Configuration menu .....5-22**
  - 5.5.1 PCH Configuration ..... 5-23
  - 5.5.2 Miscellaneous Configuration ..... 5-25
  - 5.5.3 Server ME Configuration..... 5-25
  - 5.5.4 Runtime Error Logging Support ..... 5-26
- 5.6 Socket Configuration menu .....5-26**
  - 5.6.1 Processor Configuration..... 5-27
  - 5.6.2 Common RefCode Configuration ..... 5-28
  - 5.6.3 UPI Configuration..... 5-29
  - 5.6.4 Memory Configuration..... 5-30
  - 5.6.5 IIO Configuration..... 5-32
  - 5.6.6 Advanced Power Management Configuration..... 5-33
- 5.7 Event Logs menu .....5-34**
  - 5.7.1 Change Smbios Event Log Settings ..... 5-34
  - 5.7.2 View Smbios Event Log ..... 5-34
- 5.8 Server Mgmt menu.....5-35**
- 5.9 Security menu .....5-36**
- 5.10 Boot menu .....5-39**
- 5.11 Tool menu .....5-40**
- 5.12 Exit menu .....5-41**

## Chapter 6: RAID Configuration

- 6.1 Setting up RAID.....6-2**
  - 6.1.1 RAID definitions ..... 6-2
  - 6.1.2 Installing hard disk drives..... 6-3
  - 6.1.3 Setting the RAID item in BIOS ..... 6-3
  - 6.1.4 RAID configuration utilities..... 6-3
- 6.2 Intel® Rapid Storage Technology enterprise  
SATA/SSATA Option ROM Utility .....6-4**
  - 6.2.1 Creating a RAID set..... 6-5
  - 6.2.2 Deleting a RAID set..... 6-7
  - 6.2.3 Resetting disks to Non-RAID ..... 6-8
  - 6.2.4 Exiting the Intel® Rapid Storage Technology enterprise  
SATA/SSATA Option ROM utility..... 6-9
  - 6.2.5 Rebuilding the RAID..... 6-9
  - 6.2.6 Setting the Boot array in the BIOS Setup Utility..... 6-11

# Contents

<b>6.3</b>	<b>Intel® Rapid Storage Technology enterprise (Windows)</b> .....	<b>6-12</b>
6.3.1	Creating a RAID set .....	6-13
6.3.2	Changing a Volume Type.....	6-15
6.3.3	Deleting a volume .....	6-16
6.3.4	Preferences.....	6-17
<b>6.4</b>	<b>Intel® Virtual Raid on CPU in BIOS</b> .....	<b>6-18</b>
6.4.1	Creating a RAID set .....	6-19
6.4.2	Deleting a RAID set.....	6-20

## Chapter 7: Driver Installation

<b>7.1</b>	<b>RAID driver installation</b> .....	<b>7-2</b>
7.1.1	Creating a USB flash drive with RAID drive .....	7-2
7.1.2	Installing the RAID controller driver.....	7-2
<b>7.2</b>	<b>Management applications and utilities installation</b> .....	<b>7-5</b>
<b>7.3</b>	<b>Running the Support DVD</b> .....	<b>7-5</b>
<b>7.4</b>	<b>Intel® chipset device software installation</b> .....	<b>7-8</b>
<b>7.5</b>	<b>VGA driver installation</b> .....	<b>7-10</b>
<b>7.6</b>	<b>Intel® Rapid Storage Technology enterprise 5.0 installation</b> .....	<b>7-12</b>

## Appendix

<b>Z11PP-D24 block diagram</b> .....	<b>A-2</b>
<b>Notices</b> .....	<b>A-3</b>
REACH .....	A-4
Australia statement notice.....	A-4
<b>ASUS contact information</b> .....	<b>A-5</b>

# Safety information

## Electrical Safety

- Before installing or removing signal cables, ensure that the power cables for the system unit and all attached devices are unplugged.
- To prevent electrical shock hazard, disconnect the power cable from the electrical outlet before relocating the system.
- When adding or removing any additional devices to or from the system, ensure that the power cables for the devices are unplugged before the signal cables are connected. If possible, disconnect all power cables from the existing system before you add a device.
- If the power supply is broken, do not try to fix it by yourself. Contact a qualified service technician or your dealer.

## Operation Safety

- Any mechanical operation on this server must be conducted by certified or experienced engineers.
- Before operating the server, carefully read all the manuals included with the server package.
- Before using the server, ensure all cables are correctly connected and the power cables are not damaged. If any damage is detected, contact your dealer as soon as possible.
- To avoid short circuits, keep paper clips, screws, and staples away from connectors, slots, sockets and circuitry.
- Avoid dust, humidity, and temperature extremes. Place the server on a stable surface.
- If you encounter technical problems with the product, contact a qualified service technician or your retailer.



---

This product is equipped with a three-wire power cable and plug for the user's safety. Use the power cable with a properly grounded electrical outlet to avoid electrical shock.

---

### Lithium-Ion Battery Warning

**CAUTION!** Danger of explosion if battery is incorrectly replaced. Replace only with the same or equivalent type recommended by the manufacturer. Dispose of used batteries according to the manufacturer's instructions.

### Heavy System

**CAUTION!** This server system is heavy. Ask for assistance when moving or carrying the system.

# About this guide

## Audience

This user guide is intended for system integrators, and experienced users with at least basic knowledge of configuring a server.

## Contents

This guide contains the following parts:

**1. Chapter 1: Product Introduction**

This chapter describes the general features of the server, including sections on front panel and rear panel specifications.

**2. Chapter 2: Hardware Information**

This chapter lists the hardware setup procedures that you have to perform when installing or removing system components.

**3. Chapter 3: Installation Options**

This chapter describes how to install optional components into the barebone server.

**4. Chapter 4: Motherboard Information**

This chapter gives information about the motherboard that comes with the server. This chapter includes the motherboard layout, jumper settings, and connector locations.

**5. Chapter 5: BIOS Setup**

This chapter tells how to change system settings through the BIOS Setup menus and describes the BIOS parameters.

**6. Chapter 6: RAID Configuration**

This chapter provides instructions for setting up, creating and configuring RAID sets using the available utilities.

**7. Chapter 7: Driver Installation**

This chapter provides instructions for installing the necessary drivers for different system components.

## Conventions

To ensure that you perform certain tasks properly, take note of the following symbols used throughout this manual.



**DANGER/WARNING:** Information to prevent injury to yourself when trying to complete a task.



**CAUTION:** Information to prevent damage to the components when trying to complete a task.



**IMPORTANT:** Instructions that you **MUST** follow to complete a task.



**NOTE:** Tips and additional information to help you complete a task.

## Typography

### **Bold text**

Indicates a menu or an item to select.

### *Italics*

Used to emphasize a word or a phrase.

### <Key>

Keys enclosed in the less-than and greater-than sign means that you must press the enclosed key.

Example: <Enter> means that you must press the Enter or Return key.

### <Key1>+<Key2>+<Key3>

If you must press two or more keys simultaneously, the key names are linked with a plus sign (+).

Example: <Ctrl>+<Alt>+<Del>

### Command

Means that you must type the command exactly as shown, then supply the required item or value enclosed in brackets.

Example: At the DOS prompt, type the command line:  
`format A: /S`

## References

Refer to the following sources for additional information, and for product and software updates.

### 1. **ASUS Control Center (ACC) user guide**

This manual tells how to set up and use the proprietary ASUS server management utility. Visit [asuscontrolcenter.asus.com](http://asuscontrolcenter.asus.com) for more information.

### 2. **ASUS websites**

The ASUS websites worldwide provide updated information for all ASUS hardware and software products. Refer to the ASUS contact information.

# Product Introduction

# 1

This chapter describes the general features of the chassis kit. It includes sections on front panel and rear panel specifications.

# 1.1 System package contents

Check your system package for the following items.

Model Name	RS720-E9-RS8	RS720-E9-RS8-G
Chassis	ASUS R2P-A-R22475 2U Rackmount Chassis	ASUS R2P-A-R22475 2U Rackmount Chassis
Motherboard	ASUS Z11PP-D24 Server Board	ASUS Z11PP-D24 Server Board
Component	1 x 800W 80 PLUS Platinum Power Supply	1 x 1200W 80 PLUS Platinum Power Supply
	1 x SAS/SATA/NVMe back panel	1 x SAS/SATA/NVMe back panel
	8 x Hot-swap 2.5"/3.5" Front Storage Device Bays	8 x Hot-swap 2.5"/3.5" Front Storage Device Bays
	2 x Hot-swap 2.5" Rear Storage Device Bays (optional)	1 x Front Panel Board
	1 x Front Panel Board	4 x Riser Cards
	4 x Riser Cards or 3 x Riser Cards with 2 x 2.5" hot-swap drive bays	4 x System Fans
	4 x System Fans	4 x GPU Fans
	1 x PCIE-NVME4-OCuLINK Card (optional)	1 x PCIE-NVME4-OCuLINK Card (optional)
	1 x PCIE-NVME2-OCuLINK Card (optional for model with rear bay)	
		1 x RS720-E9-RS8 Support CD
Accessories	1 x Bag of Screws	1 x Bag of Screws
	2 x CPU Heatsink	2 x CPU Heatsink
	2 x AC Power Cable	2 x AC Power Cable
Optional Items	1 x Redundant 850W 80 PLUS Titanium Power Supply (Second PSU)	1 x Redundant 1300W 80 PLUS Platinum Power Supply (Second PSU)
	1 x Friction Rail Kit	1 x Friction Rail Kit
	1 x Slim type DVD-RW	1 x Slim type DVD-RW



If any of the above items is damaged or missing, contact your retailer.

## 1.2 Serial number label

The product's serial number contains 12 characters such as xxS0xxxxxxx and printed on the sticker at the server's front cover.

The correct serial number of the product is required if you need to request for support from the ASUS Technical Support team.

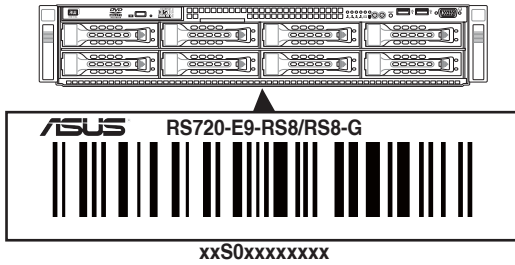

### 1.3 System specifications

The ASUS RS720-E9-RS8/RS8-G features the ASUS Z11PP-D24 server board. The server supports Intel® Xeon® Scalable Processors Family Series (Intel® Xeon® Scalable Processors Family Series with OMNI-PATH FABRIC supported on CPU2) plus other latest technologies through the chipsets onboard.

Model Name		RS720-E9-RS8	RS720-E9-RS8-G
Motherboard		Z11PP-D24	
Processor Support		2 x Socket P0 (LGA 3647) Intel® Xeon® Scalable Processors Family Intel® Xeon® Scalable Processors Family with OMNI-PATH FABRIC (supported on CPU2) UPI 10.4 GT/s	
Core Logic		Intel® Lewisburg PCH C621	
Memory	Total Slots	24 (6-channel per CPU, 12 DIMM per CPU)	
	Capacity	Maximum up to 3072GB	
	Memory Type	DDR4 2666 / 2400 / 2133 RDIMM / LRDIMM / LRDIMM 3DS * Refer to ASUS server AVL for the latest update	
	Memory Size	4GB, 8GB, 16GB, 32GB (RDIMM) 32GB, 64GB (LRDIMM) 64GB, 128GB (LRDIMM 3DS) 128GB, 256GB * Refer to ASUS server AVL for the latest update ** Refer to Intel website for AEP DIMM	
Expansion Slots	Total PCI/PCI-X/PCI-E/PIKE Slots	8+1	6+1
	Slot Type	6 x PCI-E x16 (Gen3 x8 link) or 3 x PCI-E x16 (Gen3 x16 link), FH, HL 1 x PCI-E x16 (Gen3 x16 link), LP, HL 1 x PCI-E x16 (Gen3 x8 link), FH, HL 1 x OCP Mezzanine 2.0 (Gen3 x16 link)	2 x PCI-E x16 (Gen3 x16 link), FH, FL (for GPU*2) 2 x PCI-E x16 (Gen3 x8 link) or 1 x PCI-E x16 (Gen3 x16 link), FH, HL 1 x PCI-E x16 (Gen3 x16 link), LP, HL 1 x PCI-E x16 (Gen3 x8 link), FH, HL 1 x OCP Mezzanine 2.0 (Gen3 x16 link)
Disk Controller	SATA Controller	Intel® Lewisburg PCH 10 x SATA 6Gb/s ports + 1 x M.2 connector (SATA 6Gb/s & PCI-E Gen3 x4 link) or 9 x SATA 6Gb/s ports + 2 x M.2 connector (SATA 6Gb/s & PCI-E Gen3 x4 link) Intel® RSTe (for Windows and Linux; Support software RAID 0, 1, 10 & 5) Intel® VROC (for Windows and Linux; Support software RAID 0, 1, 10 & 5)	

(continued on the next page)

Model Name		RS720-E9-RS8	RS720-E9-RS8-G
Disk Controller	SAS Controller	<b>Optional:</b> ASUS PIKE II 3008 8-port SAS HBA card ASUS PIKE II 3108 8-port SAS HW RAID card 12G SAS Support	
Storage Bays	I = internal A or S will be hot-swappable	<b>Front bays:</b> 8 x 2.5"/3.5" Hot-swap Storage Device Bays (4 x SATA/SAS + 4 x SATA/SAS/NVMe)	
		<b>Rear bays:</b> 2 x 2.5" Hot-swap drive bays (2 x SATA/NVMe) (optional) 2 x M.2 (22110, 2280, 2260, 2242) (support SATA/PCIe M.2, SATA RAID)	<b>Rear bays:</b> 2 x M.2 (22110, 2280, 2260, 2242) (support SATA/PCIe M.2, SATA RAID)
	PCIe NVMe Riser Card & Cable	4 Ports Riser Card + Cable 1 x PCIe-NVMe2-OCuLink card (optional for model with rear bay)	4 Ports Riser Card + Cable
Networking	LAN	1 x Dual Port Intel I350-AM2 Gigabit LAN controller (by default) 2 or 4 x 1G/10GbE LAN Port (with OCP card option) 1 x Management Port	
Graphic	VGA	Aspeed AST2500 64MB	
I/O Ports, Switches, and LEDs		<b>Front I/O Ports:</b> 2 x USB 2.0 ports 1 x VGA port <b>Rear I/O Ports:</b> 2 x USB 3.1 Gen 1 ports 1 x VGA port 2 x RJ-45 GbE LAN ports 1 x RJ-45 Mgmt LAN port <b>Rear Switch/LED:</b> 1 x Power switch 1 x Q-Code/Port 80 LED 1 x Message LED 1 x HDD LED 1 x Location LED <b>Front Switch/LED:</b> 1 x Power switch/LED 1 x Location switch/LED 1 x Reset switch 1 x Storage device access LED 1 x Message LED LAN 1-4 LEDs * LAN 3-4 for Mezzanine card use	

(continued on the next page)

Model Name		RS720-E9-RS8	RS720-E9-RS8-G
Management Solution	Out of Band Remote Hardware	On-Board ASMB9-iKVM for KVM-over-IP	
	Software	ASUS Control Center (Classic)	
OS Support		Windows® Server 2012 R2 Windows® Server 2016 (x86_64) RedHat® Enterprise Linux SuSE® Linux Enterprise Server CentOS Scientific Linux Ubuntu Fedora VMware Citrix XenServer * Refer to <a href="http://www.asus.com">http://www.asus.com</a> for the latest OS support.	
Dimension (Depth x Width x Height)		750 mm x 444 mm x 88 mm (2U) 29.52" x 17.48" x 3.46"	
Power Supply (different configuration by region)		1+1 Redundant 800W 80 PLUS Platinum Power Supply 850W 80 PLUS Titanium Power Supply Rating: 100-127Vac/200-240Vac, 10A/5A, 50/60Hz, Class I (240Vdc only for China)	1+1 Redundant 1200W 80 PLUS Platinum Power Supply (for 165W CPU and below) * When input voltage is 110V, power supply redundancy will be lost. 1300W 80 PLUS Platinum Power Supply (for 205W CPU) Rating: 100-127Vac/200-240Vac, 10A/5A, 50/60Hz, Class I (240Vdc only for China)
Environment		Operating temperature: 10°C ~ 35°C Non operating temperature: -40°C ~ 60°C Non operating humidity: 20% ~ 90% (Non condensing)	

\* Specifications are subject to change without notice.

## 1.4 Front panel features

The barebone server displays a simple yet stylish front panel with easily accessible features. The power and reset buttons, LED indicators, and two USB ports are located on the front panel.



Refer to section 1.7 LED information for the LED descriptions.

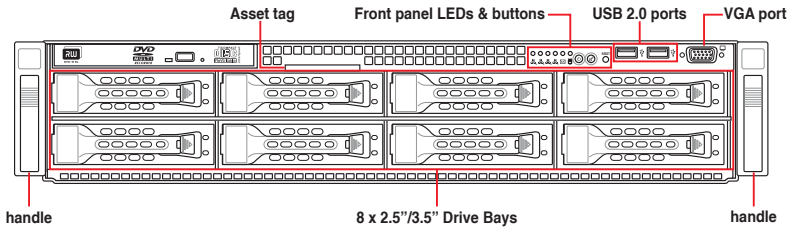

## 1.5 Rear panel features

The rear panel includes the expansion slots, system power sockets, and rear fans. The middle part includes the I/O shield with openings for the rear panel connectors on the motherboard.

### RS720-E9-RS8 (without rear bay model)

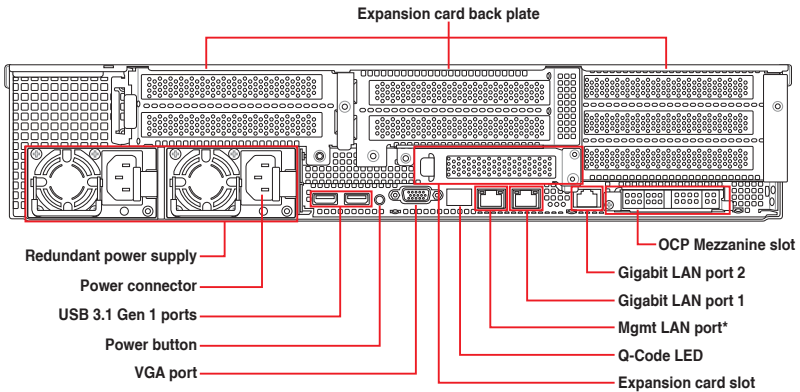

- \* This port is for ASUS ASMB9-iKVM only.
- The Q-Code LED provides the most probable cause of an error code as a starting point for troubleshooting. The actual cause may vary from case to case.
- Refer to the Q-Code table for details.

## RS720-E9-RS8 (with rear bay model)

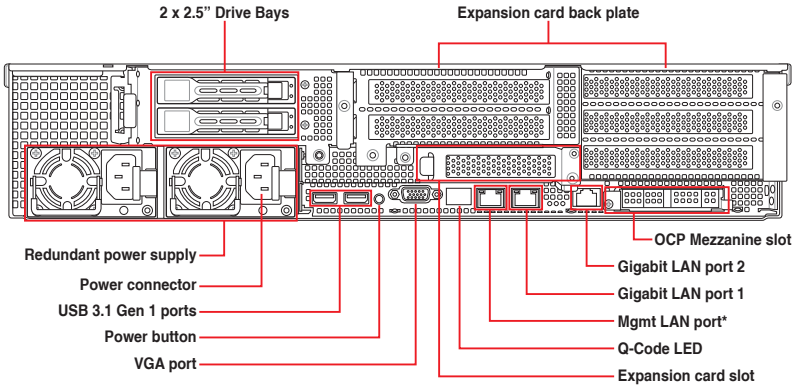

- \* This port is for ASUS ASMB9-iKVM only.
- The Q-Code LED provides the most probable cause of an error code as a starting point for troubleshooting. The actual cause may vary from case to case.
- Refer to the Q-Code table for details.

## RS720-E9-RS8-G

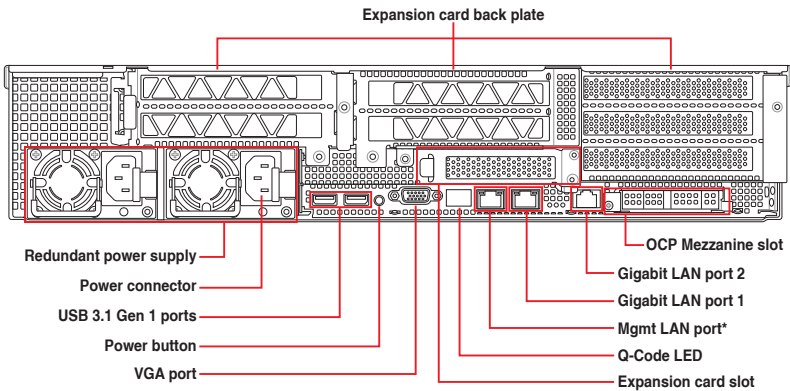

- \* This port is for ASUS ASMB9-iKVM only.
- The Q-Code LED provides the most probable cause of an error code as a starting point for troubleshooting. The actual cause may vary from case to case.
- Refer to the Q-Code table for details.

## 1.6 Internal features

The barebone server includes the basic components as shown.

### RS720-E9-RS8 (without rear bay model)

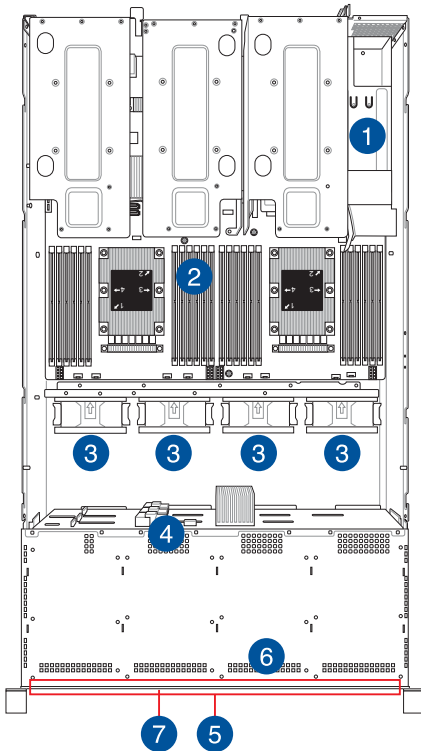

1. Redundant Power supply
2. ASUS Z11PP-D24 Server Board
3. System fans
4. SATA/SAS back panel
5. 8 x 2.5"/3.5" storage device trays
6. Front panel (hidden)
7. Asset tag (hidden)



The barebone server does not include a floppy disk drive. Connect a USB floppy disk drive to any of the USB ports on the front or rear panel if you need to use a floppy disk.



A protection film is pre-attached to the front cover before shipping. Please remove the protection film before turning on the system for proper heat dissipation.

**WARNING**  
**HAZARDOUS MOVING PARTS**  
**KEEP FINGERS AND OTHER BODY PARTS AWAY**

## RS720-E9-RS8 (with rear bay model)

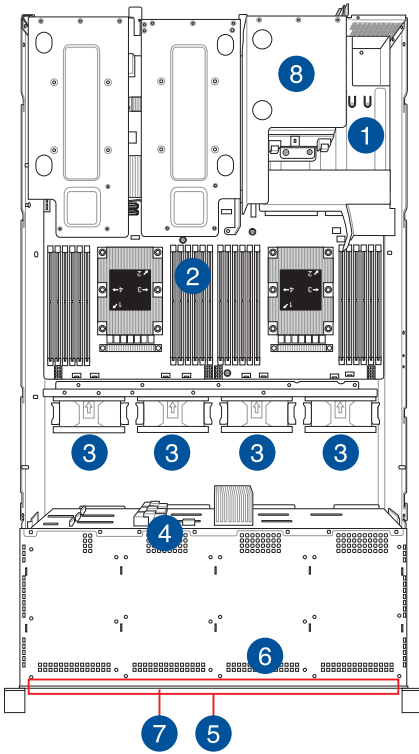

1. Redundant Power supply
2. ASUS Z11PP-D24 Server Board
3. System fans
4. SATA/SAS back panel
5. 8 x 2.5"/3.5" storage device trays
6. Front panel (hidden)
7. Asset tag (hidden)
8. 2 x 2.5" storage device trays



The barebone server does not include a floppy disk drive. Connect a USB floppy disk drive to any of the USB ports on the front or rear panel if you need to use a floppy disk.



A protection film is pre-attached to the front cover before shipping. Please remove the protection film before turning on the system for proper heat dissipation.

**WARNING**  
**HAZARDOUS MOVING PARTS**  
**KEEP FINGERS AND OTHER BODY PARTS AWAY**

## RS720-E9-RS8-G

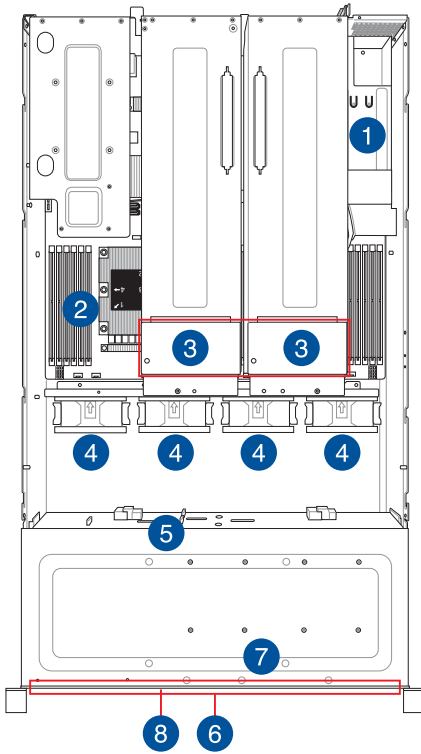

1. Redundant Power supply
2. ASUS Z11PP-D24 Server Board
3. GPU fans
4. System fans
5. SATA/SAS back panel
6. 8 x 2.5"/3.5" storage device trays
7. Front panel (hidden)
8. Asset tag (hidden)



The barebone server does not include a floppy disk drive. Connect a USB floppy disk drive to any of the USB ports on the front or rear panel if you need to use a floppy disk.



A protection film is pre-attached to the front cover before shipping. Please remove the protection film before turning on the system for proper heat dissipation.

**WARNING**  
**HAZARDOUS MOVING PARTS**  
**KEEP FINGERS AND OTHER BODY PARTS AWAY**

# 1.7 LED information

## 1.7.1 Front panel LEDs

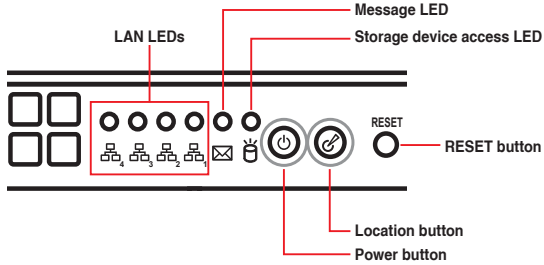

LED	Icon	Display status	Description
Power LED	⏻	ON	System power ON
Storage device access LED	🗄️	OFF	No activity
		Blinking	Read/write data into the storage device
Message LED	✉️	OFF	System is normal; no incoming event
		ON	With the onboard ASMB8-iKVM: a hardware monitor event is indicated
LAN LEDs	🌐	OFF	No LAN connection
		Blinking	LAN is transmitting or receiving data
		ON	LAN connection is present
Location LED	📍	ON	Location switch is pressed
		OFF	Normal status (Press the location switch again to turn off)

## 1.7.2 Storage device status LED

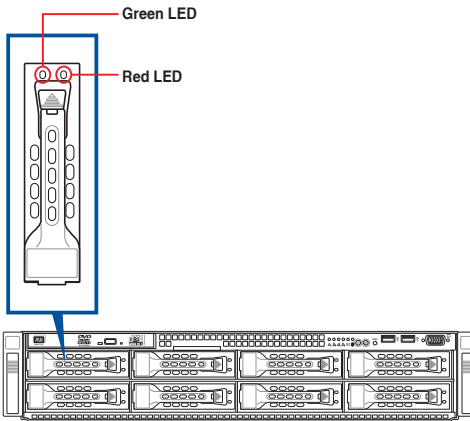

### SATA/SAS Storage Device LED Description

GREEN	ON	SATA/SAS storage device power ON
RED	ON	Storage device has failed and should be swapped immediately
GREEN/RED	Blinking	RAID rebuilding
GREEN/RED	Blinking	Locate
GREEN/RED	OFF	Storage device not found
GREEN	Blinking	Read/write data from/into the SATA/SAS storage device

## 1.7.3 LAN (RJ-45) LEDs

ACT/LINK LED    SPEED LED



ACT/LINK LED		SPEED LED	
Status	Description	Status	Description
OFF	No link	OFF	10 Mbps connection
GREEN	Linked	ORANGE	100 Mbps connection
BLINKING	Data activity	GREEN	1 Gbps connection

## 1.7.4 Q-Code table

Action	PHASE	POST CODE	TYPE	DESCRIPTION
SEC Start up	Security Phase	0x01	Progress	First post code
		0x02	Progress	Load BSP microcode
		0x03	Progress	Perform early platform Initialization
		0x04	Progress	Set cache as ram for PEI phase
		0x05	Progress	Establish Stack
		0x06	Progress	CPU Early Initialization
PSP Boot	PSP Boot Loader phase (Error Post Codes)	0x00	Error	General - Success
		0x01	Error	Generic Error Code
		0x02	Error	Generic Memory Error
		0x03	Error	Buffer Overflow
		0x04	Error	Invalid Parameter(s)
		0x05	Error	Invalid Data Length
		0x06	Error	Data Alignment Error
		0x07	Error	Null Pointer Error
		0x08	Error	Unsupported Function
		0x09	Error	Invalid Service ID
		0x0A	Error	Invalid Address
		0x0B	Error	Out of Resource Error
		0x0C	Error	Timeout
		0x0D	Error	data abort exception
		0x0E	Error	prefetch abort exception
		0x0F	Error	Out of Boundary Condition Reached
		0x10	Error	Data corruption
		0x11	Error	Invalid command
		0x12	Error	The package type provided by BR is incorrect
		0x13	Error	Failed to retrieve FW header during FW validation
		0x14	Error	Key size not supported
		0x15	Error	Agesa0 verification error
		0x16	Error	SMU FW verification error
		0x17	Error	OEM SINGING KEY verification error
		0x18	Error	Generic FW Validation error
		0x19	Error	RSA operation fail - bootloader
		0x1A	Error	CCP Passthrough operation failed - internal status
		0x1B	Error	AES operation fail
		0x1C	Error	CCP state save failed
		0x1D	Error	CCP state restore failed
		0x1E	Error	SHA256 operation fail - internal status
		0x1F	Error	ZLib Decompression operation fail
		0x20	Error	HMAC-SHA256 operation fail - internal status
		0x21	Error	Booted from boot source not recognized by PSP
		0x22	Error	PSP directory entry not found
		0x23	Error	PSP failed to set the write enable latch
		0x24	Error	PSP timed out because spirom took too long
		0x25	Error	Cannot find BIOS directory
0x26	Error	SpiRom is not valid		
0x27	Error	slave die has different security state from master		
0x28	Error	SMI interface init failure		
0x29	Error	SMI interface generic error		
0x2A	Error	invalid die ID executes MCM related function		
0x2B	Error	invalid MCM configuration table read from bootrom		
0x2C	Error	Valid boot mode wasn't detected		
0x2D	Error	NVStorage init failure		
0x2E	Error	NVStorage generic error		
0x2F	Error	MCM 'error' to indicate slave has more data to send		
0x30	Error	MCM error if data size exceeds 32B		
0x31	Error	Invalid client id for SVC MCM call		
0x32	Error	MCM slave status register contains bad bits		
0x33	Error	MCM call was made in a single die environment		
0x34	Error	PSP secure mapped to invalid segment (should be 0x400_0000)		
0x35	Error	No physical x86 cores were found on die		
0x36	Error	Insufficient space for secure OS (range of free SRAM to SVC stack base)		
0x37	Error	SYSHUB mapping memory target type is not supported		
0x38	Error	Attempt to unmap permanently mapped TLB to PSP secure region		

(continued on the next page)

Action	PHASE	POST CODE	TYPE	DESCRIPTION
PSP Boot	PSP Boot Loader phase (Error Post Codes)	0x39	Error	Unable to map an SMN address to AXI space
		0x3A	Error	Unable to map a SYSHUB address to AXI space
		0x3B	Error	The count of CCXs or cores provided by bootrom is not consistent
		0x3C	Error	Uncompressed image size doesn't match value in compressed header
		0x3D	Error	Compressed option used in case where not supported
		0x3E	Error	Fuse info on all dies don't match
		0x3F	Error	PSP sent message to SMU; SMU reported an error
		0x40	Error	Function RunPostX86ReleaseUnitTests failed in memcmp()
		0x41	Error	Interface between PSP to SMU not available.
		0x42	Error	Timer wait parameter too large
		0x43	Error	Test harness module reported an error
		0x44	Error	x86 wrote C2PMSG_0 interrupting PSP
		0x45	Error	A write to an L3 register failed
		0x46	Error	Mini-BL
		0x47	Error	Mini-BL CCP HMAC Unit-test failed
		0x48	Error	Potential stack corruption in jump to Mini BL
		0x49	Error	Error in Validate and Loading AGESA APOB SVC call
		0x4A	Error	Correct fuse bits for DIAG_BL loading not set
		0x4B	Error	The UmcProgramKeys() function was not called by AGESA
		0x4C	Error	Secure unlock error
		0x4D	Error	Syshub register programming mismatch during readback
		0x4E	Error	Family ID in MPO_SFUSE_SEC[7:3] not correct
		0x4F	Error	An operation was invoked that can only be performed by the GM
		0x50	Error	Failed to acquire host controller semaphore to claim ownership of SMB
		0x51	Error	Timed out waiting for host to complete pending transactions
		0x52	Error	Timed out waiting for slave to complete pending transactions
		0x53	Error	Unable to kill current transaction on host
		0x54	Error	One of: Illegal command
		0x55	Error	An SMBus transaction collision detected
		0x56	Error	Transaction failed to be started or processed by host
		0x57	Error	An unsolicited SMBus interrupt was received
		0x58	Error	An attempt to send an unsupported PSP-SMU message was made
		0x59	Error	An error/data corruption detected on response from SMU for sent msg
		0x5A	Error	MCM Steady-state unit test failed
		0x5B	Error	S3 Enter failed
		0x5C	Error	AGESA BL did not set PSP SMU reserved addresses via SVC call
		0x5E	Error	CcxSecBisiEn not set in fuse RAM
		0x5F	Error	Received an unexpected result
		0x60	Error	VMG Storage Init failed
		0x61	Error	Failure in mbedTLS user app
		0x62	Error	An error occurred whilst attempting to SMN map a fuse register
		0x63	Error	Fuse burn sequence/operation failed due to internal SOC error
		0x64	Error	Fuse sense operation timed out
		0x65	Error	Fuse burn sequence/operation timed out waiting for burn done
0x66	Error	Failure status indicating that the given SecureOS has been		
0x67	Error	This PSP FW was revoked		
0x68	Error	The platform model/vendor id fuse is not matching the BIOS public key token		
0x69	Error	The BIOS OEM public key of the BIOS was revoked for this platform		
0x6A	Error	PSP level 2 directory not match expected value.		
0x6B	Error	BIOS level 2 directory not match expected value.		
0x6C	Error	HVB validation failure for BIOS RTM volume (OEM public/signature failed to validate).		
0x6D	Error	Generic error indicating the CCP HAL initialization failed		
0x94	Error	Knoll failed to idle correctly after being reset		
0x95	Error	Bad status returned by I2CKnollCheck		
0x96	Error	NACK to general call (no device on Knoll I2C bus)		
0x97	Error	Null pointer passed to I2CKnollCheck		
0x98	Error	Invalid device-ID found during Knoll authentication		
0x99	Error	Error during Knoll/Prom key derivation		
0x9A	Error	Null pointer passed to Crypto function		
0x9B	Error	Error in checksum from wrapped Knoll/Prom keys		
0x9C	Error	Knoll returned an invalid response to a command		
0x9D	Error	Bootloader failed in Knoll Send Command function		
0x9E	Error	No Knoll device found by verifying MAC		

(continued on the next page)

Action	PHASE	POST CODE	TYPE	DESCRIPTION
		0xA0	Progress	Bootloader successfully entered C Main
		0xA1	Progress	Master initialized C2P / slave waited for master to init C2P
		0xA2	Progress	HMAC key successfully derived
		0xA3	Progress	Master got Boot Mode and sent boot mode to all slaves
		0xA4	Progress	SpiRom successfully initialized
		0xA5	Progress	BIOS Directory successfully read from SPI to SRAM
		0xA6	Progress	Early unlock check
		0xA7	Progress	Inline Aes key successfully derived
		0xA8	Progress	Inline-AES key programming is done
		0xA9	Progress	Inline-AES key wrapper derivation is done
		0xAA	Progress	Bootloader successfully loaded HW IP configuration values
		0xAB	Progress	Bootloader successfully programmed MBAT table
		0xAC	Progress	Bootloader successfully loaded SMU FW
		0xAD	Progress	PSP and SMU configured WAFI
		0xAE	Progress	User mode test harness completed successfully
		0xAF	Progress	Bootloader loaded Agesa0 from SpiRom
		0xB0	Progress	AGESA phase has completed
		0xB1	Progress	RunPostDramTrainingTests() completed successfully
		0xB2	Progress	SMU FW Successfully loaded to SMU Secure DRAM
		0xB3	Progress	Sent all required boot time messages to SMU
		0xB4	Progress	Validated and ran Security Gasket binary
		0xB5	Progress	UMC Keys generated and programmed
		0xB6	Progress	Inline AES key wrapper stored in DRAM
		0xB7	Progress	Completed FW Validation step
		0xB8	Progress	Completed FW Validation step
		0xB9	Progress	BIOS copy from SPI to DRAM complete
		0xBA	Progress	Completed FW Validation step
		0xBB	Progress	BIOS load process fully complete
		0xBC	Progress	Bootloader successfully release x86
		0xBD	Progress	Early Secure Debug completed
		0xBE	Progress	GetFWVersion command received from BIOS is completed
		0xBF	Progress	SMInfo command received from BIOS is completed
		0xC0	Progress	Successfully entered WarmBootResume()
		0xC1	Progress	Successfully copied SecureOS image to SRAM
		0xC2	Progress	Successfully copied trustlets to PSP Secure Memory
		0xC3	Progress	About to jump to Secure OS (SBL about to copy and jump)
		0xC4	Progress	Successfully restored CCP and UMC state on S3 resume
		0xC5	Progress	PSP SRAM HMAC validated by Mini BL
		0xC6	Progress	About to jump to -t-base in Mini BL
		0xC7	Progress	VMG ECDH unit test started
		0xC8	Progress	VMG ECDH unit test passed
		0xC9	Progress	VMG ECC CDH primitive unit test started
		0xCA	Progress	VMG ECC CDH primitive unit test passed
		0xCB	Progress	VMG SP800-108 KDF-CTR HMAC unit test started
		0xCC	Progress	VMG SP800-108 KDF-CTR HMAC unit test passed
		0xCD	Progress	VMG LAUNCH * test started
		0xCE	Progress	VMG LAUNCH * test passed
		0xCF	Progress	MP1 has been taken out of reset
		0xD0	Progress	PSP and SMU Reserved Addresses correct
		0xD1	Progress	Reached Naples steady-state WFI loop
		0xD2	Progress	Knoll device successfully initialized
		0xD3	Progress	32-byte RandOut successfully returned from Knoll
		0xD4	Progress	32-byte MAC successfully received from Knoll.
		0xD5	Progress	Knoll device verified successfully
		0xD6	Progress	Done enabling power for Knoll
		0xD7	Progress	Enter recovery mode due to trustlet validation fail.
		0xD8	Progress	Enter recovery mode due to OS validation fail.
		0xD9	Progress	Enter recovery mode due to OEM public key not found.

PSP Boot  
PSP Boot Loader  
phase (Status Post  
Codes)

(continued on the next page)

Action	PHASE	POST CODE	TYPE	DESCRIPTION		
Quick VGA	PEI(Pre-EFI Initialization) phase	0x10	Progress	PEI Core Entry		
		0x11	Progress	PEI cache as ram CPU initial		
		0x15	Progress	NB Initialization before installed memory		
		0x19	Progress	SB Initialization before installed memory		
		0x32	Progress	CPU POST-Memory Initialization		
		0x33	Progress	CPU Cache Initialization		
		0x34	Progress	Application Processor(s) (AP) Initialization		
		0x35	Progress	BSP Selection		
		0x36	Progress	CPU Initialization		
	DXE(Driver Execution Environment) phase	0x37	Progress	Pre-memory NB Initialization		
		0x3B	Progress	Pre-memory SB Initialization		
		0x4F	Progress	DXE Initial Program Load(IPL)		
		0x60	Progress	DXE Core Started		
		0x61	Progress	DXE NVRAM Initialization		
		0x62	Progress	SB run-time Initialization		
		0x63	Progress	CPU DXE Initialization		
		0x68	Progress	PCI HB Initialization		
		0x69	Progress	NB DXE Initialization		
		0x6A	Progress	NB DXE SMM Initialization		
		0x70	Progress	SB DXE Initialization		
		0x71	Progress	SB DXE SMM Initialization		
		0x72	Progress	SB DEVICES Initialization		
		0x78	Progress	ACPI Module Initialization		
		0x79	Progress	CSM Initialization		
		0xD0	Progress	CPU PM Structure Initialization		
		Normal boot	BDS(Boot Device Selection) phase	0x90	Progress	BDS started
				0x91	Progress	Connect device event
				0x92	Progress	PCI Bus Enumeration
	0x93			Progress	PCI Bus Enumeration	
	0x94			Progress	PCI Bus Enumeration	
	0x95			Progress	PCI Bus Enumeration	
	0x96			Progress	PCI Bus Enumeration	
	0x97			Progress	Console output connect event	
	0x98			Progress	Console input connect event	
	0x99			Progress	AMI Super IO start	
	0x9A			Progress	AMI USB Driver Initialization	
	0x9B			Progress	AMI USB Driver Initialization	
	0x9C			Progress	AMI USB Driver Initialization	
	0x9D			Progress	AMI USB Driver Initialization	
0xb2	Progress			Legacy Option ROM Initialization		
0xb3	Progress			Reset system		
0xb4	Progress			USB hotplug		
0xb6	Progress			NVRAM clean up		
0xb7	Progress			NVRAM configuration reset		
0xA0	Progress			IDE, AHCI Initialization		
0xA1	Progress			IDE, AHCI Initialization		
0xA2	Progress			IDE, AHCI Initialization		
0xA3	Progress			IDE, AHCI Initialization		
0x00-0xFF	Progress			Wait BMC ready		
0xA8	Progress			BIOS Setup Utility password verify		
0xA9	Progress			BIOS Setup Utility start		
0xAB	Progress			BIOS Setup Utility input wait		
0xAD	Progress			Ready to boot event		
0xAE	Progress			Legacy boot event		
Operating system phase	0xAA			Progress	APIC mode	
	0xAC			Progress	PIC mode	



# Hardware Information

# 2

This chapter lists the hardware setup procedures that you have to perform when installing or removing system components.

## 2.1 Chassis cover

### Removing the rear cover

To remove the rear cover:

1. Remove the screw on the rear cover with a Phillips screwdriver.

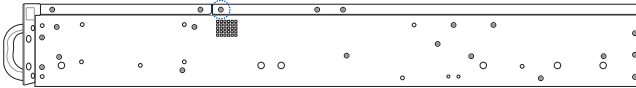

2. Push and hold the cover buttons down, then slide the rear cover towards the rear to disengage it from the chassis.
3. Lift the rear cover to completely remove it from the chassis.

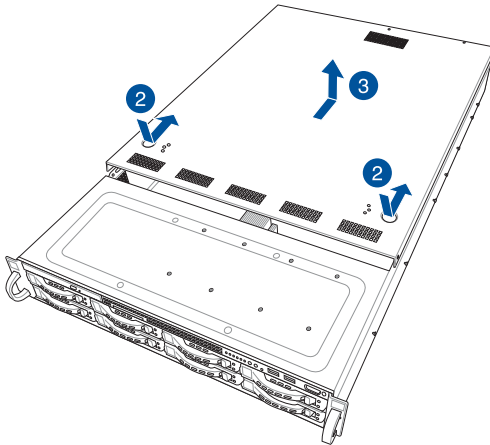

## 2.2 Central Processing Unit (CPU)

The motherboard comes with a surface mount LGA 3647 socket designed for the Intel® Xeon® Scalable Processors Family Series (supported on CPU1 and CPU2) and Intel® Xeon® Scalable Processors Family Series with OMNI-PATH FABRIC (supported on CPU2).



- Upon purchase of the motherboard, ensure that the PnP cap is on the socket and the socket contacts are not bent. Contact your retailer immediately if the PnP cap is missing, or if you see any damage to the PnP cap/socket contacts/motherboard components. ASUS will shoulder the cost of repair only if the damage is shipment/transit-related.
- Keep the cap after installing the motherboard. ASUS will process Return Merchandise Authorization (RMA) requests only if the motherboard comes with the cap on the LGA 3647 socket.
- The product warranty does not cover damage to the socket contacts resulting from incorrect CPU installation/removal, or misplacement/loss/incorrect removal of the PnP cap.

### 2.2.1 Installing the CPU and heatsink

To install a CPU:

1. Remove the rear cover. For more information, see the section **Chassis cover**.
2. Remove the air duct screw (A), remove the air ducts (B), and then remove the PnP caps (C) from the CPU sockets.



Keep the PnP cap. ASUS will process Return Merchandise Authorization (RMA) requests only if the motherboard comes with the PnP cap on the LGA 3647 socket.

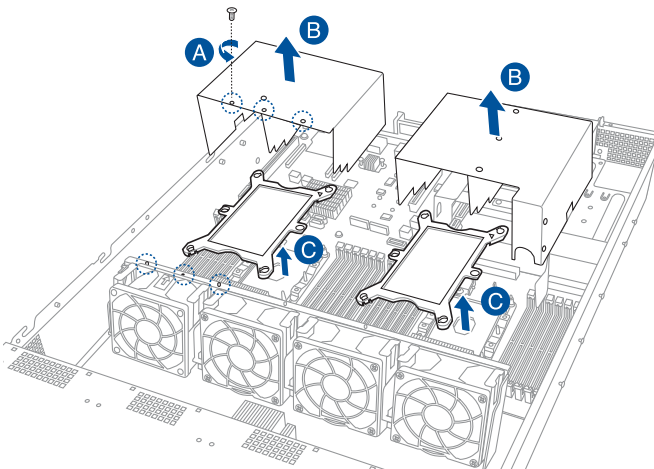

- Align the triangle mark on the CPU with the triangle mark on the CPU Carrier (A), then install the CPU into the CPU Carrier until it clicks firmly into place (B), and then install the CPU Carrier into the heatsink until it clicks firmly in place (C).



Ensure that the triangle mark on the CPU matches the triangle mark on the CPU Carrier.

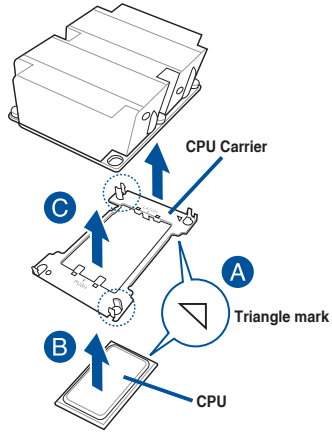

- Align the CPU and CPU Carrier in the correct orientation, and then place the heatsinks on top of the CPU sockets.



The CPU and CPU Carrier fits in only one correct orientation. DO NOT force the CPU and CPU Carrier into the socket to prevent damaging the CPU pins on the socket.

- Twist each of the four screws with a screwdriver just enough to attach the heatsink to the motherboard. When the four screws are attached, tighten them one by one in a diagonal sequence to completely secure the heatsink.



The heatsink screws are T30 models. A torque value of 12 inch-lbf is recommended.

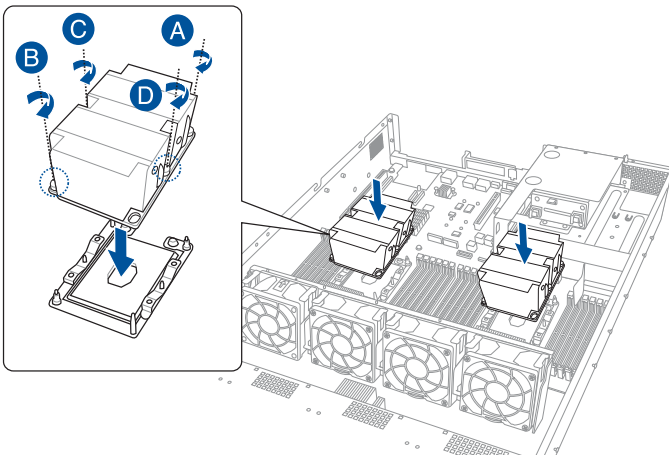

6. Reinstall the air ducts (A), and then secure the air duct with the air duct screw removed in step 2 (B).

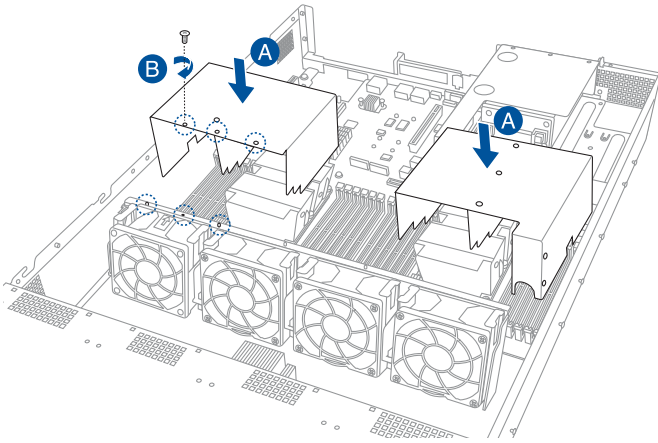

## 2.3 System memory

### 2.3.1 Overview

The motherboard comes with 24 Double Data Rate 4 (DDR4) Dual Inline Memory Modules (DIMM) sockets.

The figure illustrates the location of the DDR4 DIMM sockets:

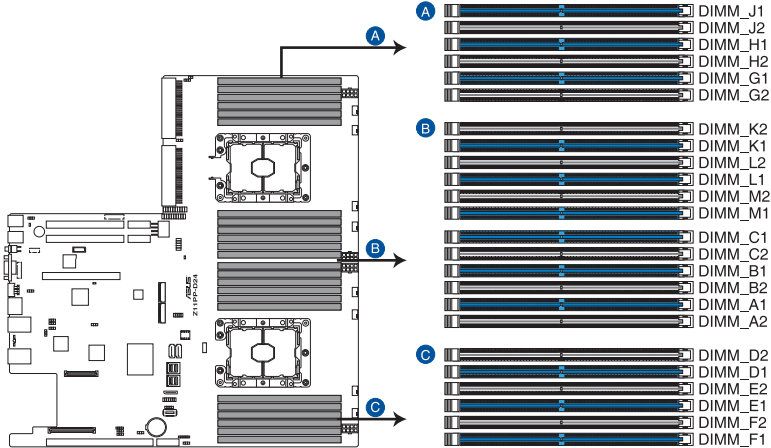

**Z11PP-D24 288-pin DDR4 DIMM sockets**

## 2.3.2 Memory Configurations

You may install 4 GB, 8 GB, 16 GB, and 32 GB RDIMMs; 32 GB, and 64 GB LRDIMMs; and 64GB and 128GB LRDIMMs (3DS) into the DIMM sockets using the memory configurations in this section.



- Refer to ASUS Server AVL for the updated list of compatible DIMMs.
- Always install DIMMs with the same CAS latency. For optimum compatibility, it is recommended that you obtain memory modules from the same vendor.

1 CPU Configuration (must be on CPU1)						
	DIMM_A2	DIMM_A1	DIMM_B2	DIMM_B1	DIMM_C2	DIMM_C1
1 DIMM		•				
2 DIMMs		•				
4 DIMMs		•		•		
6 DIMMs		•		•		•
8 DIMMs	•	•		•		•
12 DIMMs	•	•	•	•	•	•

1 CPU Configuration (must be on CPU1)						
	DIMM_D2	DIMM_D1	DIMM_E2	DIMM_E1	DIMM_F2	DIMM_F1
1 DIMM						
2 DIMMs		•				
4 DIMMs		•		•		
6 DIMMs		•		•		•
8 DIMMs	•	•		•		•
12 DIMMs	•	•	•	•	•	•

2 CPU Configuration						
	DIMM_A2	DIMM_A1	DIMM_B2	DIMM_B1	DIMM_C2	DIMM_C1
2 DIMMs		•				
4 DIMMs		•				
8 DIMMs		•		•		
12 DIMMs		•		•		•
16 DIMMs	•	•		•		•
20 DIMMs	•	•	•	•		•
24 DIMMs	•	•	•	•	•	•

2 CPU Configuration						
	DIMM_D2	DIMM_D1	DIMM_E2	DIMM_E1	DIMM_F2	DIMM_F1
2 DIMMs						
4 DIMMs		•				
8 DIMMs		•		•		
12 DIMMs		•		•		•
16 DIMMs	•	•		•		•
20 DIMMs	•	•	•	•		•
24 DIMMs	•	•	•	•	•	•

2 CPU Configuration						
	DIMM_G2	DIMM_G1	DIMM_H2	DIMM_H1	DIMM_J2	DIMM_J1
2 DIMMs		•				
4 DIMMs		•				
8 DIMMs		•		•		
12 DIMMs		•		•		•
16 DIMMs	•	•		•		•
20 DIMMs	•	•	•	•		•
24 DIMMs	•	•	•	•	•	•

2 CPU Configuration						
	DIMM_K2	DIMM_K1	DIMM_L2	DIMM_L1	DIMM_M2	DIMM_M1
2 DIMMs						
4 DIMMs		•				
8 DIMMs		•		•		
12 DIMMs		•		•		•
16 DIMMs	•	•		•		•
20 DIMMs	•	•	•	•		•
24 DIMMs	•	•	•	•	•	•

### 2.3.3 Installing a DIMM on a single clip DIMM socket



Ensure to unplug the power supply before adding or removing DIMMs or other system components. Failure to do so may cause severe damage to both the motherboard and the components.

1. Unlock a DIMM socket by pressing the retaining clip outward.
2. Align a DIMM on the socket such that the notch on the DIMM matches the DIMM slot key on the socket.

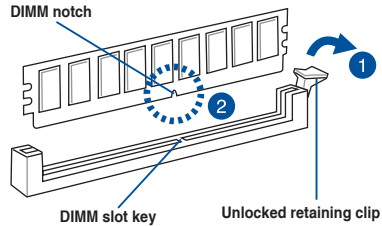

A DIMM is keyed with a notch so that it fits in only one direction. **DO NOT** force a DIMM into a socket in the wrong direction to avoid damaging the DIMM.

3. Hold the DIMM by both of its ends, then insert the DIMM vertically into the socket. Apply force to both ends of the DIMM simultaneously until the retaining clip snaps back into place and the DIMM cannot be pushed in any further to ensure proper sitting of the DIMM.

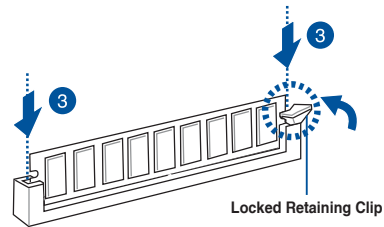

Always insert the DIMM into the socket vertically to prevent DIMM notch damage.

### 2.3.4 Removing a DIMM from a single clip DIMM socket

1. Press the retaining clip outward to unlock the DIMM.
2. Remove the DIMM from the socket.

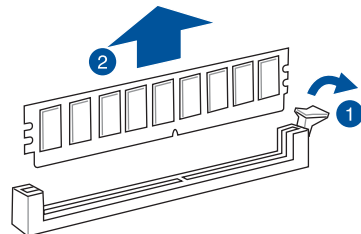

Support the DIMM lightly with your fingers when pressing the retaining clips. The DIMM might get damaged when it flips out with extra force.

## 2.4 Storage devices

The system supports eight (8) 2.5" or 3.5" hot-swap storage devices on the front panel, and two (2) additional 2.5" hot-swap storage devices on the rear panel (for RS720-E9-RS8 only). The storage device installed on the storage device tray connects to the motherboard SATA/SAS/NVMe ports via the SATA/SAS/NVMe backplane (SAS storage devices require an optional ASUS PIKE II card).

To install a 2.5" hot-swap storage device to the front panel:

1. Push the spring lock to the right (A), then pull the tray lever outward (B) to release the tray. The tray ejects slightly after you pull out the lever.

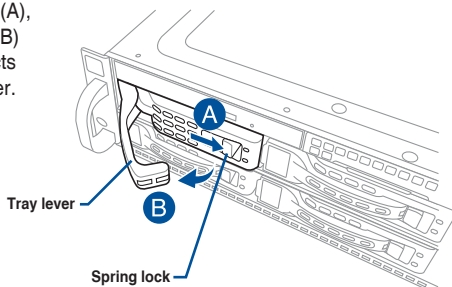

2. Firmly hold the tray lever and pull the tray out of the bay.

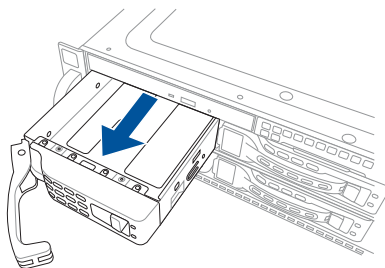

3. Place the tray on a flat and stable surface.
4. Prepare the 2.5" hot-swap storage device and the bundled set of screws.

5. Place the 2.5" hot-swap storage device into the tray, then secure it with four screws.

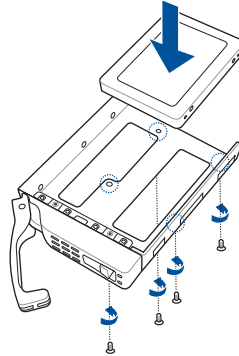

6. Insert the tray and storage device assembly all the way into the depth of the bay until just a small fraction of the tray edge protrudes.

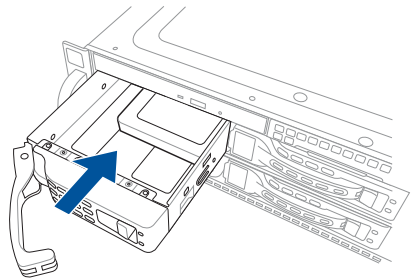

---

When installed, the SATA/SAS/NVMe connector on the storage device connects to the SATA/SAS/NVMe interface on the backplane.

---

7. Push the tray lever until it clicks and secures the tray in place.



---

The tray is correctly placed when its front edge aligns with the bay edge.

---

8. Repeat steps 1 to 7 to install the other storage devices.

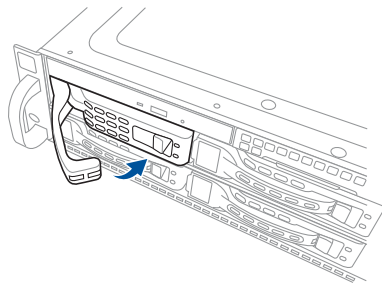

To install a 3.5" hot-swap storage device to the front panel:

1. Push the spring lock to the right (A), then pull the tray lever outward (B) to release the tray. The tray ejects slightly after you pull out the lever.

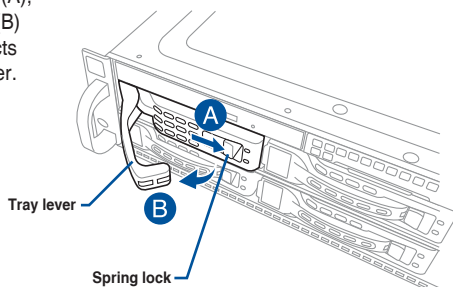

2. Firmly hold the tray lever and pull the tray out of the bay.

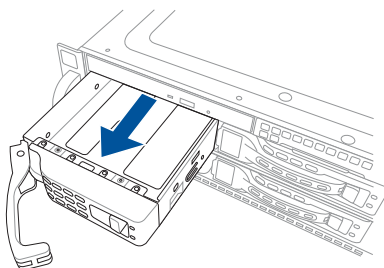

3. Place the tray on a flat and stable surface.
4. Prepare the 3.5" hot-swap storage device and the bundled set of screws.

5. Place the 3.5" hot-swap storage device into the tray, then secure it with four screws.

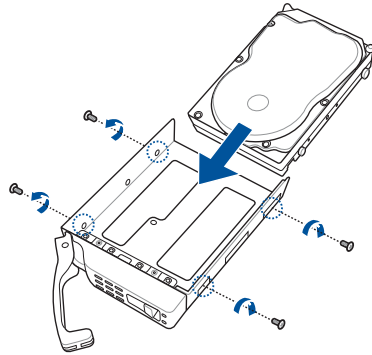

6. Insert the tray and storage device assembly all the way into the depth of the bay until just a small fraction of the tray edge protrudes.

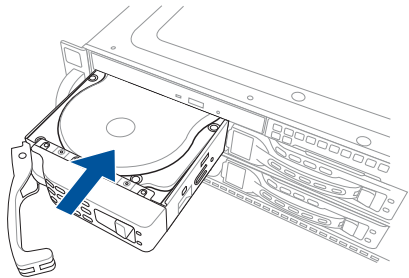

---

When installed, the SATA/SAS/NVMe connector on the storage device connects to the SATA/SAS/NVMe interface on the backplane.

---

7. Push the tray lever until it clicks and secures the tray in place.



---

The tray is correctly placed when its front edge aligns with the bay edge.

---

8. Repeat steps 1 to 7 to install the other storage devices.

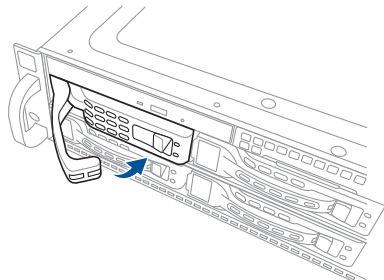

To install a 2.5" hot-swap storage device to the rear bay (for RS720-E9-RS8 only):

1. Push the spring lock to the right (A), then pull the tray lever outward (B) to release the tray. The tray ejects slightly after you pull out the lever.

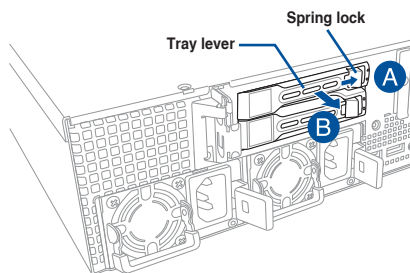

2. Firmly hold the tray lever and pull the tray out of the bay.

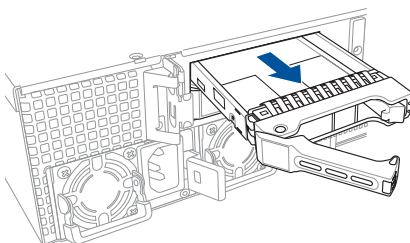

3. Place the storage device tray on a flat and stable surface.
4. Release the screws on each side of the storage device tray to release the metal beam.

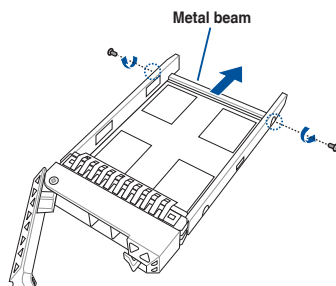

The metal beam supports the storage device tray horizontally to prevent the storage device tray from bending or deforming.

5. Place the SATA/SAS storage device into the storage device tray, then secure it with four screws.

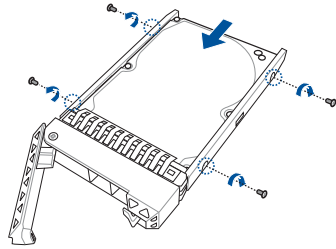

6. Insert the tray and storage device assembly all the way into the depth of the bay until just a small fraction of the tray edge protrudes.

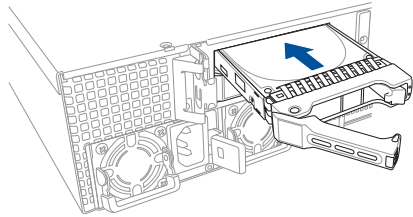

---

When installed, the SATA/SAS/NVMe connector on the storage device connects to the SATA/SAS/NVMe interface on the rear backplane.

---

7. Push the tray lever until it clicks and secures the tray in place.



---

The tray is correctly placed when its front edge aligns with the bay edge.

---

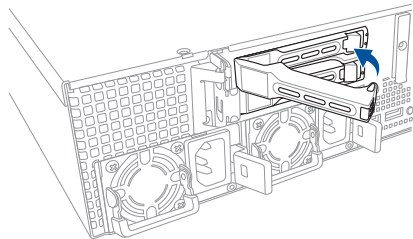

8. Repeat steps 1 to 7 to install the other storage devices.

## 2.5 Expansion slot

The barebone server comes with four pre-installed riser cards or three pre-installed riser cards with the rear 2.5" storage device bay. You need to remove these expansion card brackets if you want to install PCIe expansion cards.

### RS720-E9-RS8 (without rear bay model)

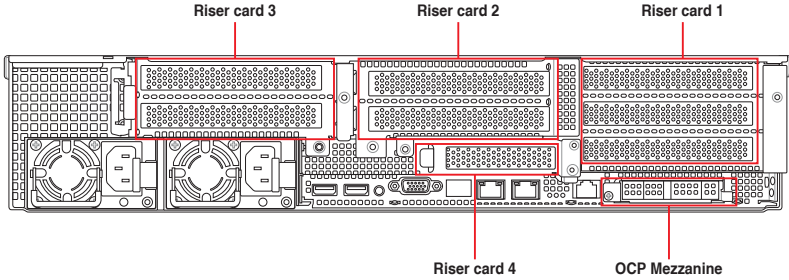

### RS720-E9-RS8 (with rear bay model)

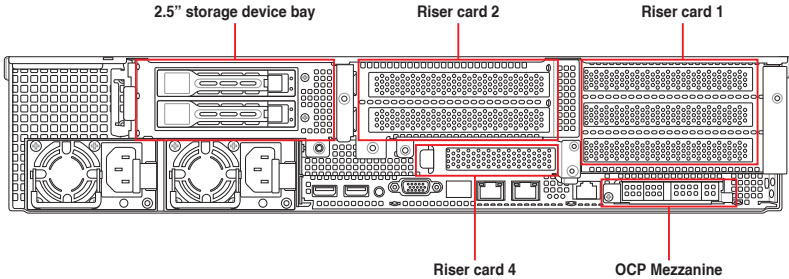

The default 2.5" storage device bay cannot be removed.

## RS720-E9-RS8-G

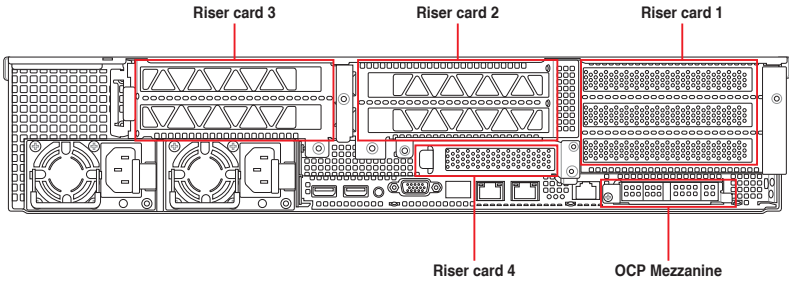

### Riser card bracket 1

Riser card bracket 1 supports PCIe Gen3 slots 1-3 top to bottom. Slot 2 can be auto-switch to x16 mode when x16 card is populated whereas slot 1 will be disabled.

PCIe slot	Operation mode	
Slot 1	x8	N/A
Slot 2	x8	x16 (NVMe 4 port riser card by option)
Slot 3	x8 (ASUS PIKE II card by option)	x8 (ASUS PIKE II card by option)

### Riser card bracket 2

Riser card bracket 2 supports PCIe Gen3 slots 4-5 top to bottom. Slot 4 can be auto-switch to x16 mode when x16 card is populated whereas slot 5 will be disabled.

PCIe slot	Operation mode	
Slot 4	x8	x16
Slot 5	x8	N/A

### Riser card bracket 3

Riser card bracket 3 supports PCIe Gen3 slots 6-7 top to bottom. Slot 7 can be auto-switch to x16 mode when x16 card is populated whereas slot 6 will be disabled.

PCIe slot	Operation mode	
Slot 6	x8	N/A
Slot 7	x8	x16

### Riser card bracket 4

Riser card bracket 4 supports PCIe Gen3 slot 8.

PCIe slot	Operation mode	
Slot 8	x16	

### OCP Mezzanine slot

OCP Mezzanine slot supports PCIe Gen3 x16.

PCIe slot	Operation mode	
OCP Mezzanine	x16	

## 2.5.1 Installing an expansion card to riser card bracket 1

The pre-installed riser card bracket 1 on the PCIe1 slot supports Full-Height (FH) and Half-Length (HL) PCIe x16 expansion cards.

To install an expansion card to the riser card bracket 1:

1. Remove the screw that secures the riser card bracket 1 to the chassis.

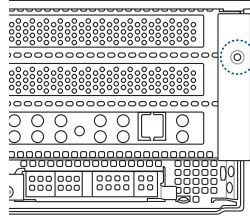

2. Firmly hold the riser card bracket 1, then pull it up to detach it from the PCIe1 slot on the motherboard.

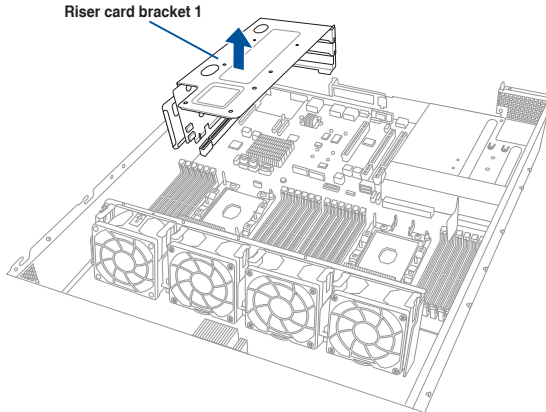

3. Remove the screw from the metal cover (A), then remove the metal cover (B) from the riser card bracket 1.

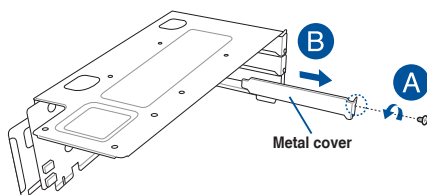

4. Install the PCIE expansion card into the riser card bracket 1 (A), then secure the expansion card with the screw (B).

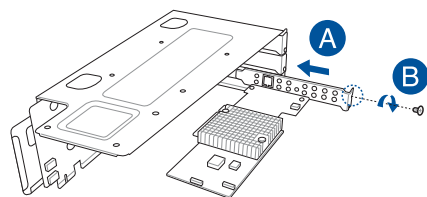

5. Install the riser card bracket 1 and the PCIE expansion card assembly into the PCIE1 slot on the motherboard. Ensure that the golden connectors of the riser card bracket 1 is firmly seated in place.

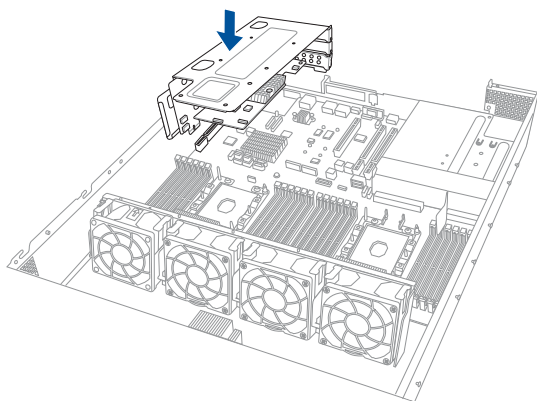

6. Secure the riser card bracket 1 to the chassis with the screw removed in step 1.

## 2.5.2 Installing an expansion card to riser card bracket 2

To install an expansion card to the riser card bracket 2:

1. Remove the two screws that secure the riser card bracket 2 to the chassis.

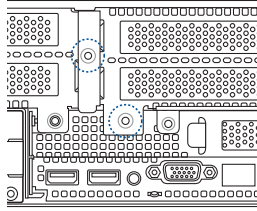

2. Remove the screw that secures the riser card bracket 2 to the motherboard.
3. Firmly hold the riser card bracket 2, then pull it up to detach it from the PCIe3 slot on the motherboard.

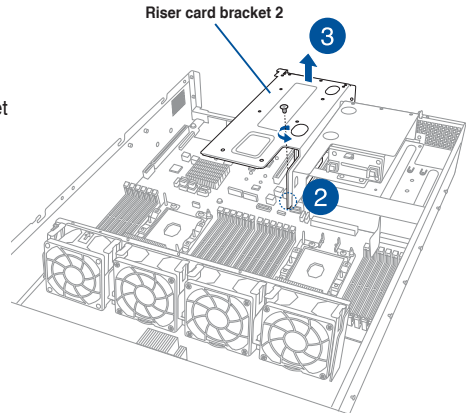

4. Remove the screw from the metal cover (A), then remove the metal cover (B) from the riser card bracket 2.

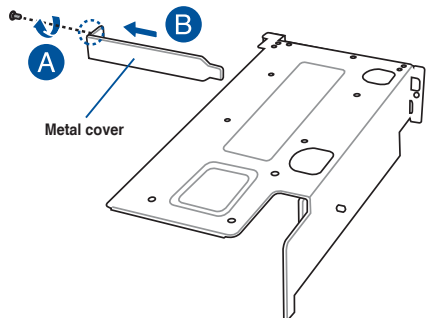

5. Install the PCIE expansion card into the riser card bracket 2 (A), then secure the expansion card with the screw (B).

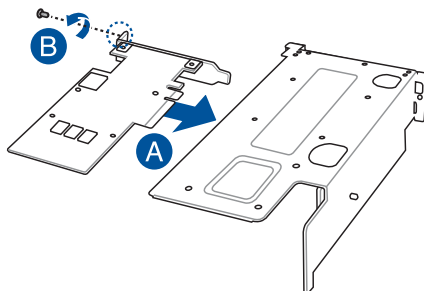

6. Install the riser card bracket 2 and the PCIE expansion card assembly into the PCIE3 slot on the motherboard. Ensure that the golden connectors of the riser card bracket 2 is firmly seated in place.
7. Secure the riser card bracket 2 to the motherboard with the screw removed in step 2.

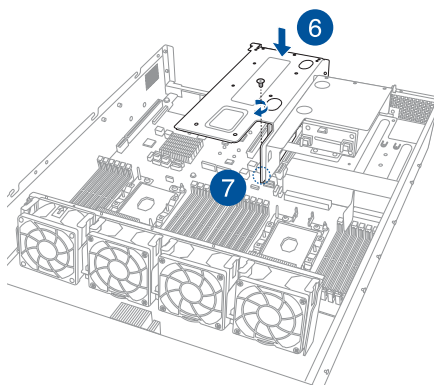

8. Secure the riser card bracket 2 to the chassis with the screws removed in step 1.

## 2.5.3 Installing an expansion card to riser card bracket 3 (for RS720-E9-RS8 only)

To install an expansion card to the riser card bracket 3:

1. Remove the two screws that secure the riser card bracket 3 to the chassis.

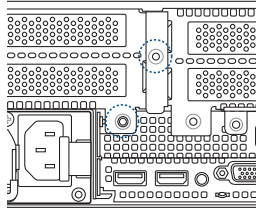

2. Firmly hold the riser card bracket 3, then pull it up to detach it from the PCIe4 slot on the motherboard.

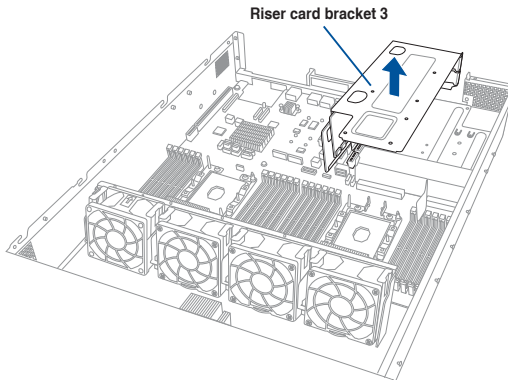

3. Remove the screw from the metal cover (A), then remove the metal cover (B) from the riser card bracket 3.

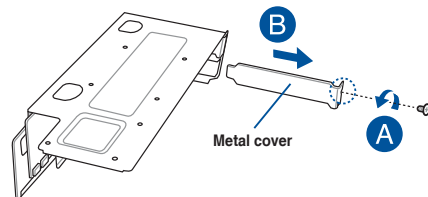

4. Install the PCIE expansion card into the riser card bracket 3 (A), then secure the expansion card with the screw (B).

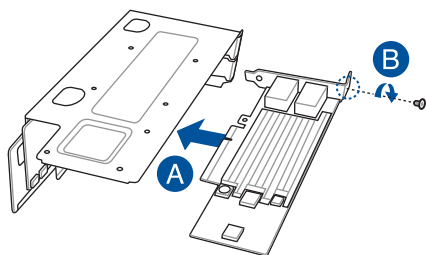

5. Install the riser card bracket 3 and the PCIE expansion card assembly into the PCIE4 slot on the motherboard. Ensure that the golden connectors of the riser card bracket 3 is firmly seated in place.

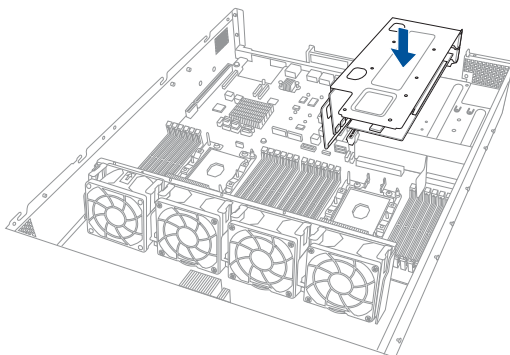

6. Secure the riser card bracket 3 to the chassis with the screws removed in step 1.

## 2.5.4 Installing an expansion card to riser card bracket 4

To install an expansion card to the riser card bracket 4:

1. Remove the riser card bracket 1 and riser card bracket 2.



For more information, refer to section 2.5.1 **Installing an expansion card to riser card bracket 1**, 2.5.2 **Installing an expansion card to riser card bracket 2**, and 2.5.5 **Installing GPU cards**.

2. Remove the screw that secures the metal lock to the chassis.

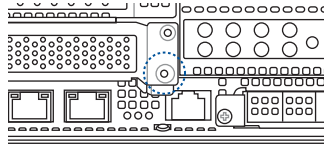

3. Lift the metal lock upward.

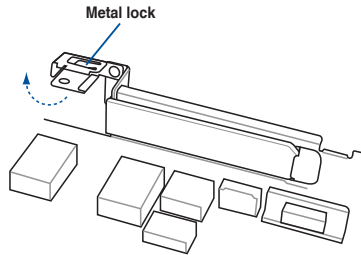

4. Remove the metal cover from the chassis.

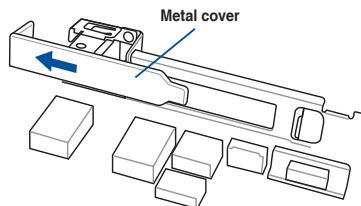

5. Install the PCIE expansion card into the riser card bracket 4.

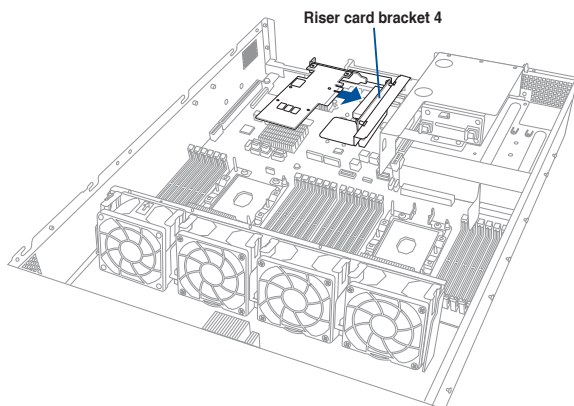

6. Move the metal lock downward to secure the riser card bracket 4 and the PCIE expansion card assembly to the chassis.

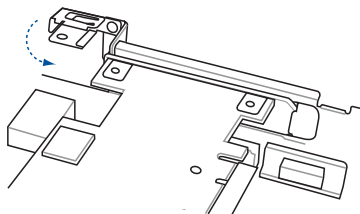

7. Secure the metal lock to the chassis with the screw removed in step 2.

## 2.5.5 Installing GPU cards (for RS720-E9-RS8-G only)

To install a passive GPU (FH/FL) card to the riser card bracket 2:

1. Remove the two screws that secure the riser card bracket 2 to the chassis.
2. Lift the strap and then pull it up to detach the riser card bracket 2 from the PCIe3 slot on the motherboard.

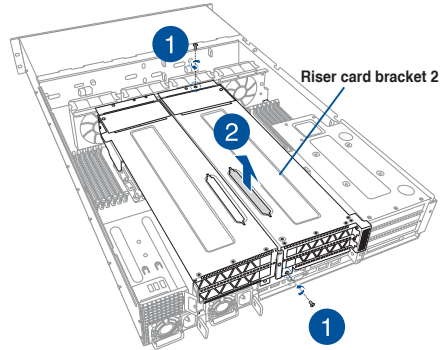

3. Place the riser card bracket 2 on a flat and stable surface in the orientation as shown.
4. Remove the screw that secures the GPU air duct to the riser card bracket 2 (A), then remove the GPU air duct (B).
5. Remove the screws from the metal cover (C), then remove the metal cover (D) from the riser card bracket 2.
6. Prepare the GPU card and the GPU power cable.

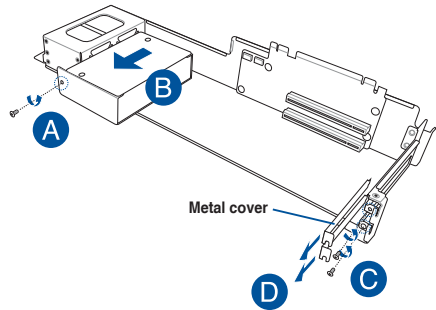

7. (Optional) Prepare the GPU card dongle, then connect it to the GPU power cable as shown.

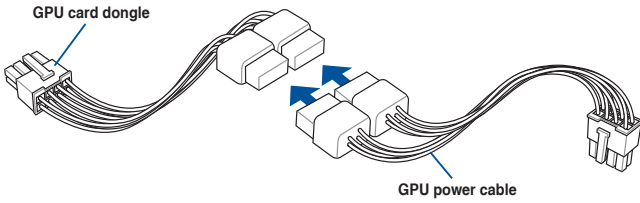

8. Connect the GPU power cable or GPU card dongle to the connector on the GPU card.
9. Align the GPU air duct to the GPU card and pass the GPU power cable (or power cable and dongle) through the notched area on the GPU air duct.
10. From inside the GPU air duct, secure the GPU air duct to the GPU card with two screws.

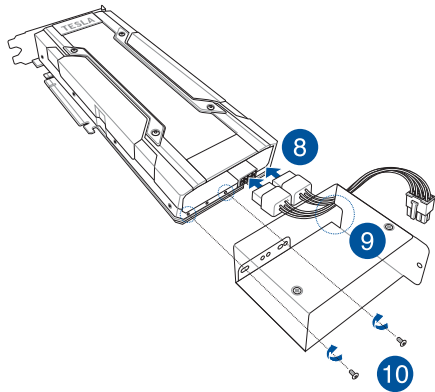

11. Install the GPU card into the riser card bracket 2.
12. Secure the GPU card to the riser card bracket 2 with the screws removed in step 5.
13. Secure the GPU air duct to the riser card bracket 2 with the screw removed in step 4.

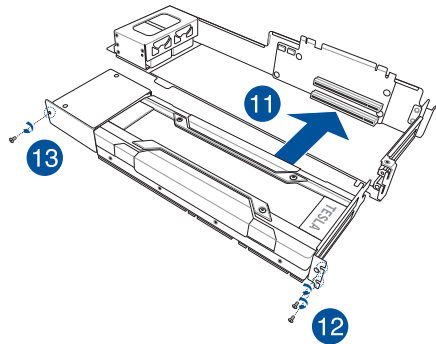

14. Connect the cable from the GPU card to the VGAPWR1 connector on the motherboard.
15. Install the riser card bracket 2 and the GPU card assembly into the PCIe3 slot on the motherboard. Ensure that the golden connectors of the riser card bracket 2 is firmly seated in place.
16. Secure the riser card bracket 2 to the chassis with the screws removed in step 1.

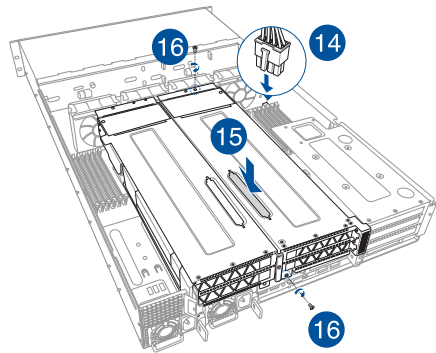

To install a passive GPU (FH/FL) card to the riser card bracket 3:

1. Remove the two screws that secure the riser card bracket 3 to the chassis.
2. Lift the strap and then pull it up to detach the riser card bracket 3 from the PCIe4 slot on the motherboard.

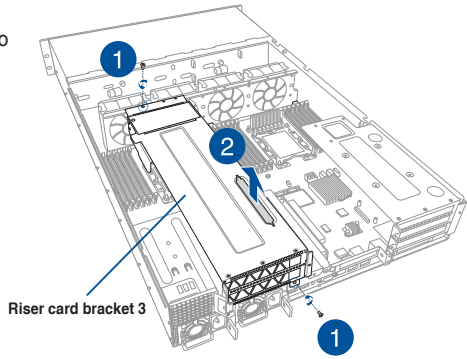

3. Place the riser card bracket 3 on a flat and stable surface in the orientation as shown.
4. Remove the screw that secures the GPU air duct to the riser card bracket 3 (A), then remove the GPU air duct (B).
5. Remove the screws from the metal cover (C), then remove the metal cover (D) from the riser card bracket 3.
6. Prepare the GPU card and the GPU power cable.

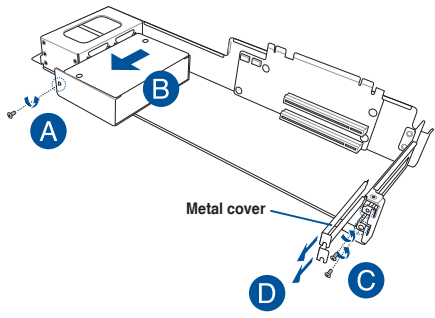

7. (Optional) Prepare the GPU card dongle, then connect it to the GPU power cable as shown.

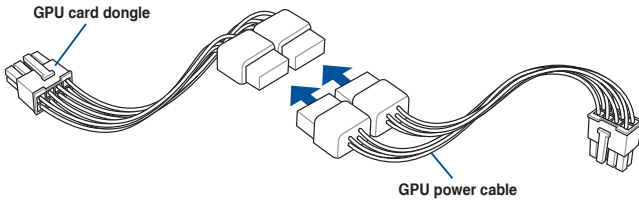

8. Connect the GPU power cable or GPU card dongle to the connector on the GPU card.
9. Align the GPU air duct to the GPU card and pass the GPU power cable (or power cable and dongle) through the notched area on the GPU air duct.
10. From inside the GPU air duct, secure the GPU air duct to the GPU card with two screws.

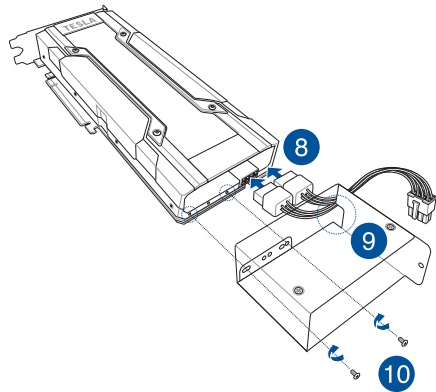

11. Install the GPU card into the riser card bracket 3.
12. Secure the GPU card to the riser card bracket 3 with the screws removed in step 5.
13. Secure the GPU air duct to the riser card bracket 3 with the screw removed in step 4.

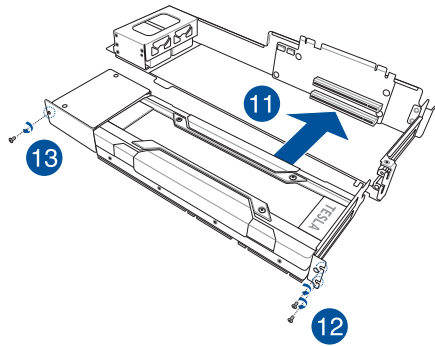

14. Connect the cable from the GPU card to the VGAPWR2 connector on the motherboard.
15. Install the riser card bracket 3 and the GPU card assembly into the PCIe4 slot on the motherboard. Ensure that the golden connectors of the riser card bracket 3 are firmly seated in place.
16. Secure the riser card bracket 3 to the chassis with the screws removed in step 1.

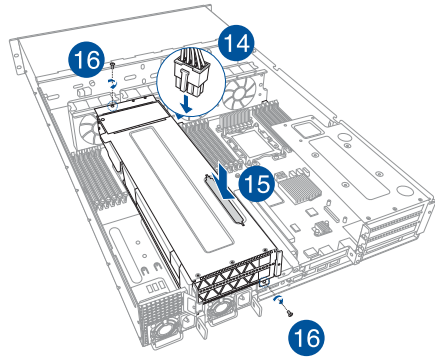

## 2.5.6 Replacing GPU cards (for RS720-E9-RS8-G only)

To replace the pre-installed passive GPU (FH/FL) card on the riser card bracket 2:

1. Remove the two screws that secure the riser card bracket 2 to the chassis.
2. Lift the strap and then pull it up to detach the riser card bracket 2 from the PCIe3 slot on the motherboard.

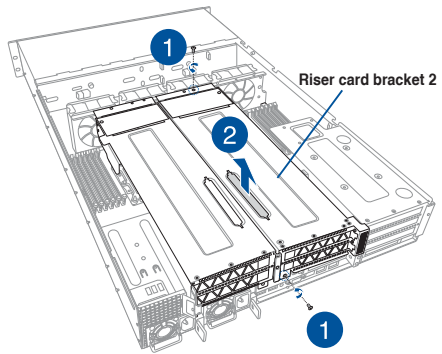

3. Place the riser card bracket 2 on a flat and stable surface in the orientation as shown.
4. Remove the screws that secure the GPU card to the riser card bracket 2.
5. Remove the screw that secures the GPU air duct to the riser card bracket 2.
6. Remove the GPU card from the riser card bracket 2.

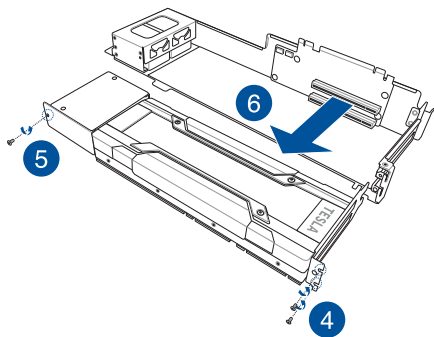

7. From inside the GPU air duct, remove the two screws that secure the GPU air duct to the GPU card.
8. Remove the GPU air duct.
9. Remove the GPU power cable or GPU card dangle from the connector on the GPU card.
10. Prepare the replacement GPU card.

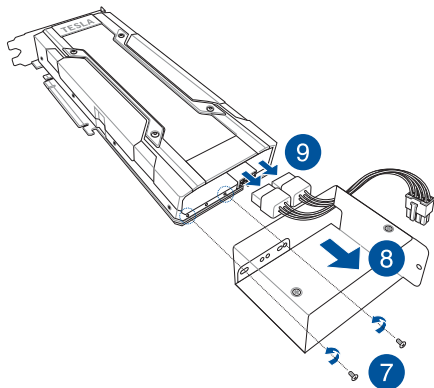

11. Reconnect the GPU power cable or GPU card dangle to the connector on the replacement GPU card.
12. Align the GPU air duct to the replacement GPU card and pass the GPU power cable (or power cable and dangle) through the notched area on the GPU air duct.
13. From inside the GPU air duct, secure the GPU air duct to the replacement GPU card with the two screws removed in step 7.

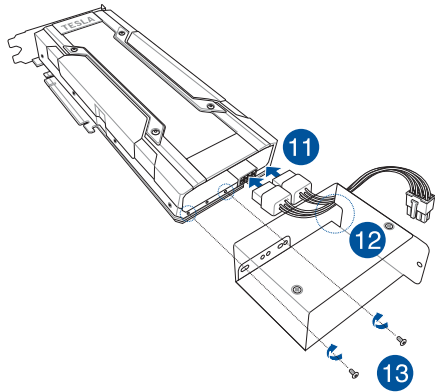

14. Install the replacement GPU card into the riser card bracket 2.
15. Secure the replacement GPU card to the riser card bracket 2 with the screws removed in step 4.
16. Secure the GPU air duct to the riser card bracket 2 with the screw removed in step 5.

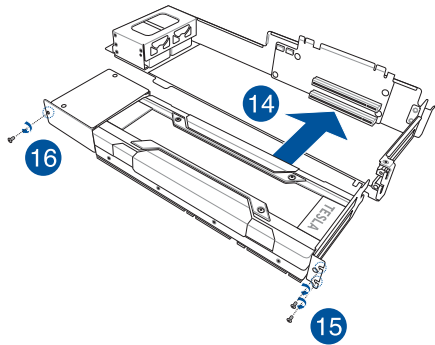

17. Install the riser card bracket 2 and the replacement GPU card assembly into the PCIe3 slot on the motherboard. Ensure that the golden connectors of the riser card bracket 2 is firmly seated in place.
18. Secure the riser card bracket 2 to the chassis with the screws removed in step 1.

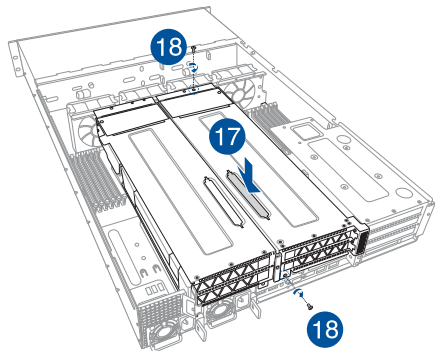

To replace the pre-installed passive GPU (FH/FL) card on the riser card bracket 3:

1. Remove the two screws that secure the riser card bracket 3 to the chassis.
2. Lift the strap and then pull it up to detach the riser card bracket 3 from the PCIe4 slot on the motherboard.

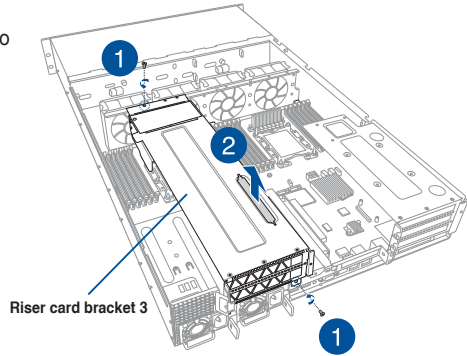

3. Place the riser card bracket 3 on a flat and stable surface in the orientation as shown.
4. Remove the screws that secure the GPU card to the riser card bracket 3.
5. Remove the screw that secures the GPU air duct to the riser card bracket 3.
6. Remove the GPU card from the riser card bracket 3.

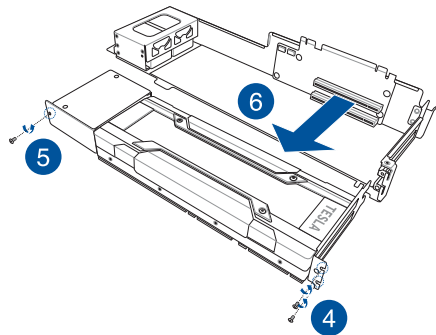

7. From inside the GPU air duct, remove the two screws that secure the GPU air duct to the GPU card.
8. Remove the GPU air duct.
9. Remove the GPU power cable or GPU card dangle from the connector on the GPU card.
10. Prepare the replacement GPU card.

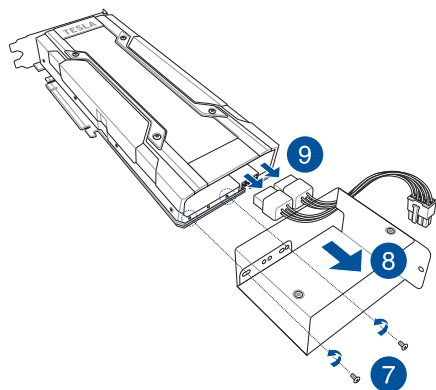

11. Reconnect the GPU power cable or GPU card dangle to the connector on the replacement GPU card.
12. Align the GPU air duct to the replacement GPU card and pass the GPU power cable (or power cable and dangle) through the notched area on the GPU air duct.
13. From inside the GPU air duct, secure the GPU air duct to the replacement GPU card with the two screws removed in step 7.

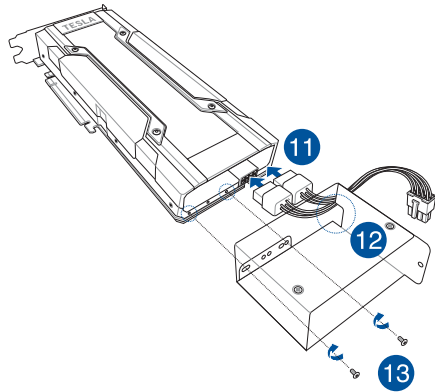

14. Install the replacement GPU card into the riser card bracket 3.
15. Secure the replacement GPU card to the riser card bracket 3 with the screws removed in step 4.
16. Secure the GPU air duct to the riser card bracket 3 with the screw removed in step 5.

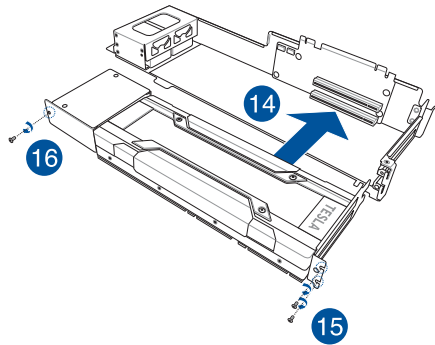

17. Install the riser card bracket 3 and the replacement GPU card assembly into the PCIe4 slot on the motherboard. Ensure that the golden connectors of the riser card bracket 3 is firmly seated in place.
18. Secure the riser card bracket 3 to the chassis with the screws removed in step 1.

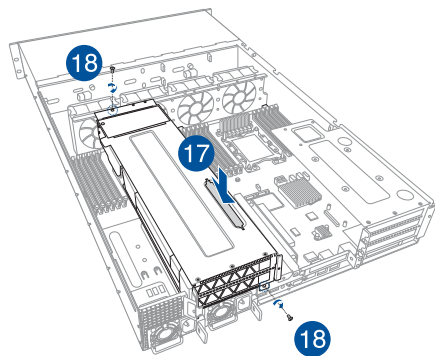

## 2.5.7 Installing an ASUS PIKE II card

To install an ASUS PIKE II card to the riser card bracket 1:

1. Remove the screw that secures the riser card bracket 1 to the chassis.

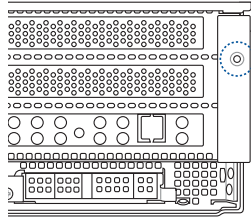

2. Firmly hold the riser card bracket 1, then pull it up to detach it from the PCIe1 slot on the motherboard.

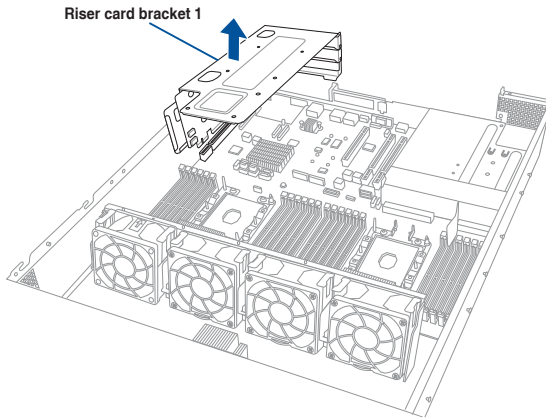

3. Remove the screw from the metal cover (A), then remove the metal cover (B) from the riser card bracket 1.

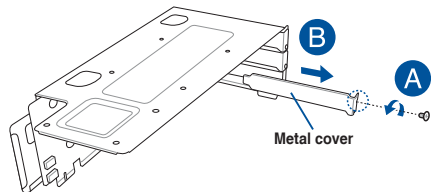

4. Prepare the ASUS PIKE II card.
5. Remove the mini-SAS HD cables from the motherboard.
6. Reconnect the mini-SAS HD cables to the ASUS PIKE II card as shown.

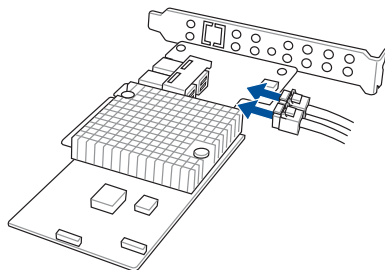

7. Install the ASUS PIKE II card into the riser card bracket 1 (A), then secure it with the screw removed in step 3 (B).

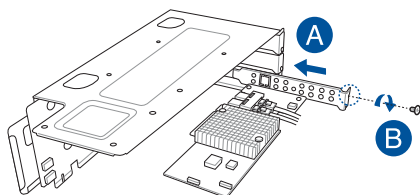

8. Install the riser card bracket 1 and the ASUS PIKE II card assembly into the PCIe1 slot on the motherboard. Ensure that the golden connectors of the riser card bracket 1 is firmly seated in place.

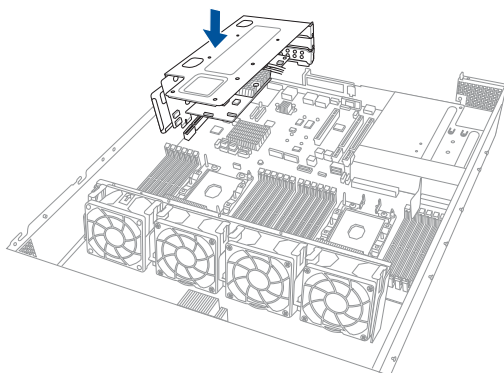

9. Secure the riser card bracket 1 to the chassis with the screw removed in step 1.

## 2.5.8 Installing an ASUS PCIE-NVME4-OCuLink card

To install an ASUS PCIE-NVME4-OCuLink card to the riser card bracket 1:

1. Remove the screw that secures the riser card bracket 1 to the chassis.

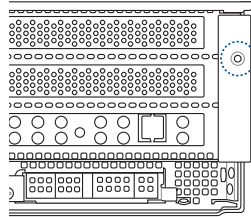

2. Firmly hold the riser card bracket 1, then pull it up to detach it from the PCIE1 slot on the motherboard.

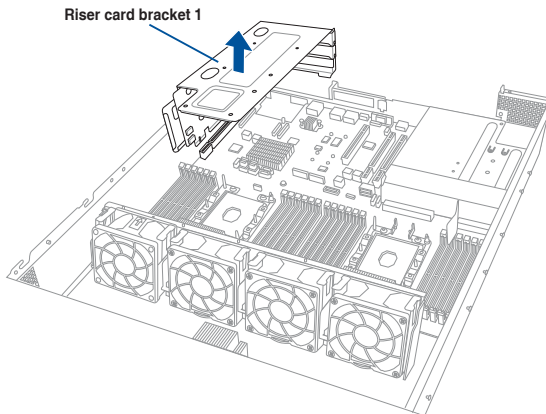

3. Place the riser card bracket 1 on a flat and stable surface in the orientation as shown.
4. Prepare the ASUS PCIE-NVME4-OCuLink card.
5. Connect the OCuLink cables to the corresponding slots.
6. Install the ASUS PCIE-NVME4-OCuLink card into the PCIE slot.

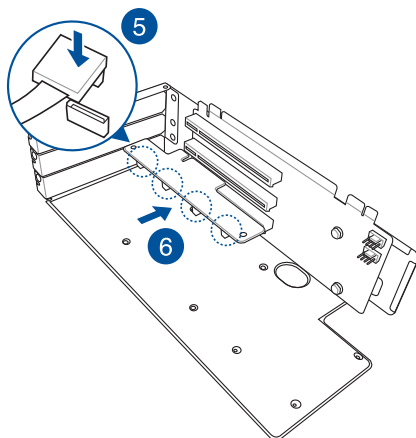

7. Install the riser card bracket 1 and the ASUS PCIE-NVME4-OCuLink card assembly into the PCIE1 slot on the motherboard. Ensure that the golden connectors of the riser card bracket 1 is firmly seated in place.

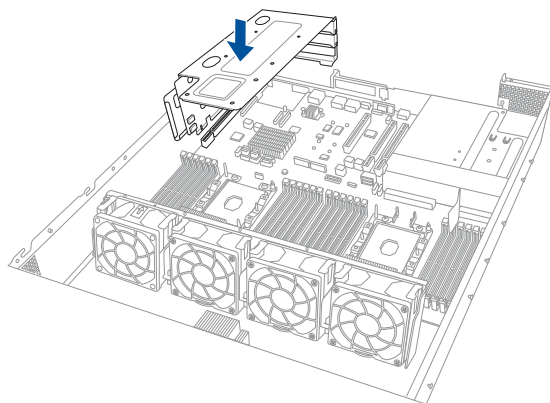

8. Secure the riser card bracket 1 to the chassis with the screw removed in step 1.

9. Connect the OCuLink cables from the ASUS PCIE-NVME4-OCuLink card to OCUPCIE1-4 slots on the backplane. Ensure that the cables follow the path as shown below.

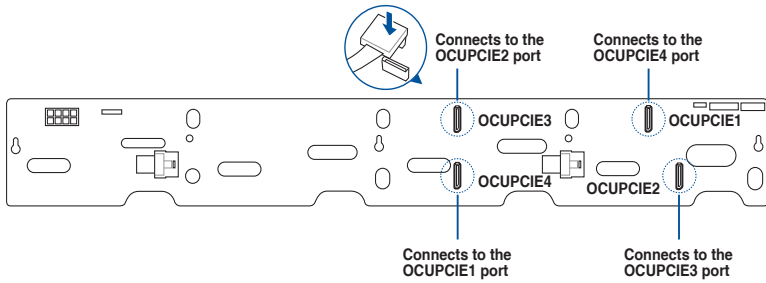

## 2.5.9 Installing an ASUS PCIE-NVME2-OCuLink card (for RS720-E9-RS8 only)

To install an ASUS PCIE-NVME2-OCuLink card to the riser card bracket 2:

1. Remove the two screws that secure the riser card bracket 2 to the chassis.

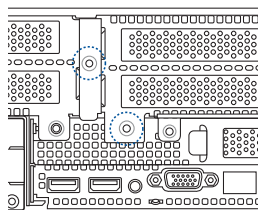

2. Remove the screw that secures the riser card bracket 2 to the motherboard.
3. Firmly hold the riser card bracket 2, then pull it up to detach it from the PCIe3 slot on the motherboard.

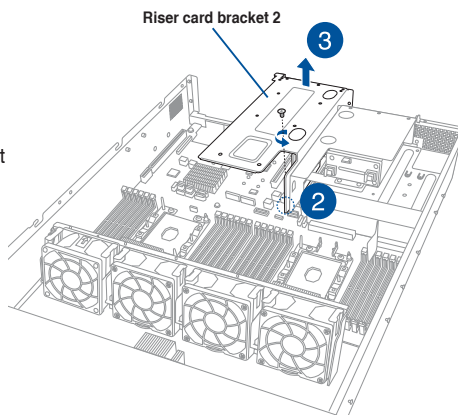

4. Place the riser card bracket 2 on a flat and stable surface in the orientation as shown.
5. Prepare the ASUS PCIE-NVME2-OCuLink card.
6. Install the ASUS PCIE-NVME2-OCuLink card into the PCIe slot.
7. Connect the OCuLink cables to the corresponding slots.

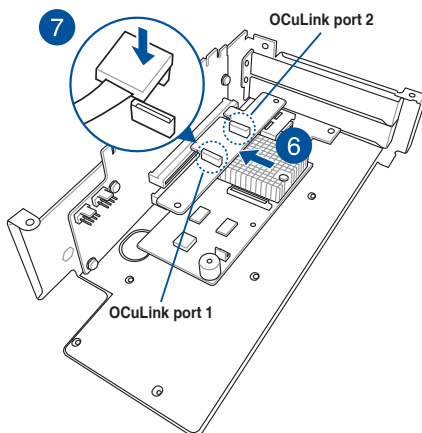

8. Install the riser card bracket 2 and the ASUS PCIE-NVME2-OCuLink card assembly into the PCIE3 slot on the motherboard. Ensure that the golden connectors of the riser card bracket 2 is firmly seated in place.
9. Secure the riser card bracket 2 to the motherboard with the screw removed in step 2.
10. Secure the riser card bracket 2 to the chassis with the screws removed in step 1.

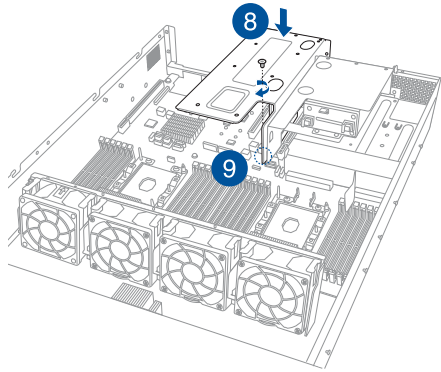

11. Locate the backplane on the 2.5" rear storage device bay.
12. Connect the OCuLink cables from the ASUS PCIE-NVME2-OCuLink card to the slots on the backplane. Ensure that the cables follow the path as shown.

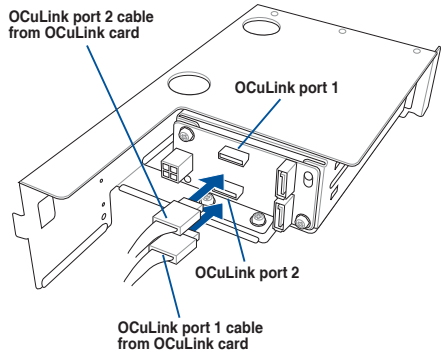

### 2.5.10 Configuring an expansion card

After installing the expansion card, configure it by adjusting the software settings.

1. Turn on the system and change the necessary BIOS settings, if any. See Chapter 5 for information on BIOS setup.
2. Assign an IRQ to the card. Refer to the following tables.
3. Install the software drivers for the expansion card.

#### Standard Interrupt assignments

IRQ	Priority	Standard function
0	1	System Timer
1	2	Keyboard Controller
2	-	Programmable Interrupt
3*	11	Communications Port (COM2)
4*	12	Communications Port (COM1)
5*	13	--
6	14	Floppy Disk Controller
7*	15	--
8	3	System CMOS/Real Time Clock
9*	4	ACPI Mode when used
10*	5	IRQ Holder for PCI Steering
11*	6	IRQ Holder for PCI Steering
12*	7	PS/2 Compatible Mouse Port
13	8	Numeric Data Processor
14*	9	Primary IDE Channel
15*	10	Secondary IDE Channel

\* These IRQs are usually available for ISA or PCI devices.

## 2.5.11 Installing Mezzanine cards

To install a Mezzanine card:

1. Locate the Mezzanine card connector on your motherboard.

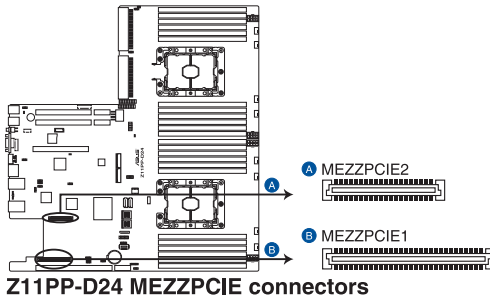

2. Remove the riser card bracket 1. For more information, refer to section **2.5.1 Installing an expansion card to riser card bracket 1**.
3. Remove the screw from the metal cover (A), then remove the metal cover (B) from chassis.

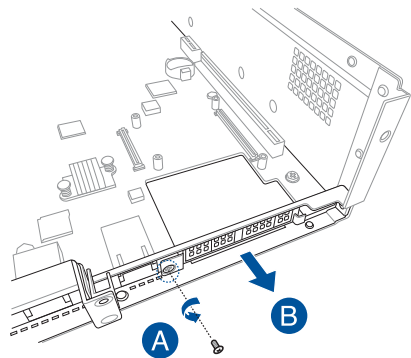

4. Select the slots that are going to be used for your Mezzanine card, then use a screwdriver and pry the corresponding slots until it pops off.

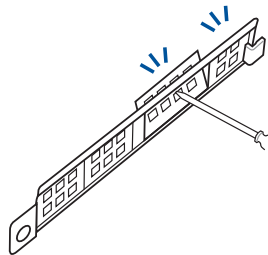

5. Prepare the Mezzanine card.
6. Insert the ports of the Mezzanine card into the mounting hole on the chassis, then insert the golden connector of the Mezzanine card into the OCP connector on the motherboard.

Ensure that the stand screws on the motherboard is aligned and matched to the screw holes of the Mezzanine card.

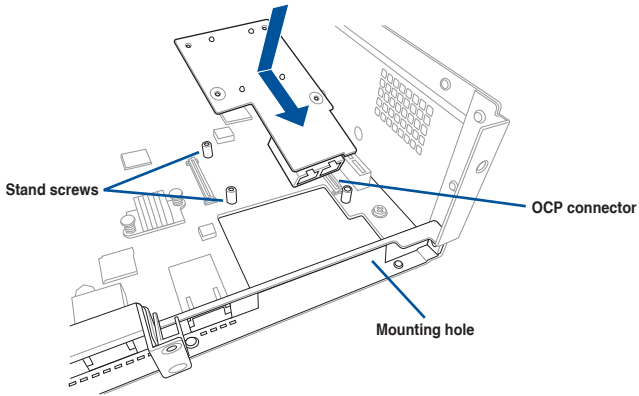

7. Secure the Mezzanine card with four bundled screws.

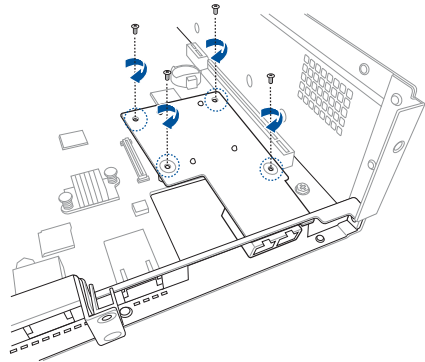

8. Reinstall the metal cover (A) and secure it with the screw (B).

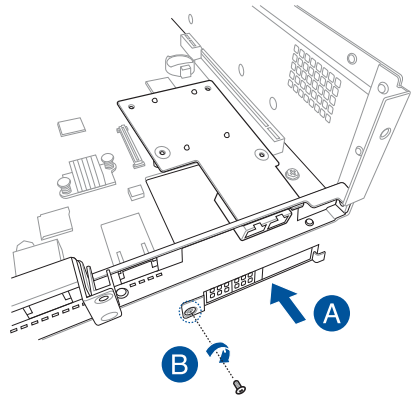

9. Install the riser card bracket 1 into the PCIe connector on the motherboard. For more information, refer to section **2.5.1 Installing an expansion card to riser card bracket 1**.

## 2.5.12 Installing M.2 (NGFF) cards

To install an M.2 (NGFF) card:

1. Locate the M.2 (NGFF) connectors on your motherboard.

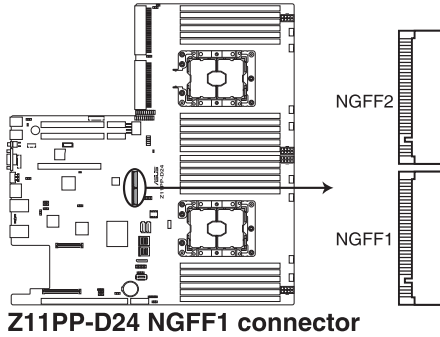

2. Remove the top screw and the stand from the motherboard.

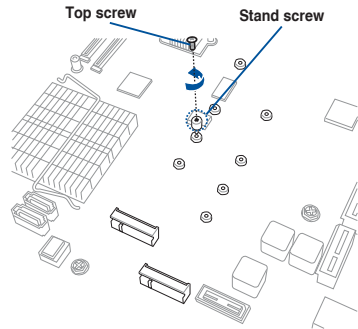

3. Select an appropriate screw hole on the motherboard for your M.2 card, then secure the stand to the motherboard.

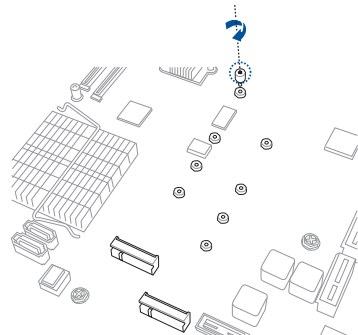

4. Prepare the M.2 card.
5. Align and insert the M.2 card into the M.2 connector on the motherboard.

Ensure that the golden connector of the M.2 card is inserted firmly in place and that the screw hole on the M.2 card matches the stand screw on the motherboard.

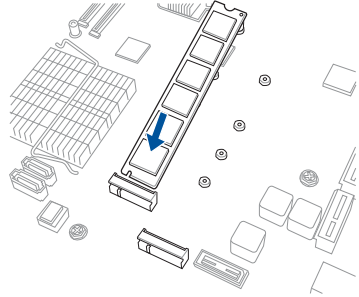

6. Secure the M.2 card with the top screw.



---

Ensure that the M.2 card is positioned between the top screw and the stand screw before securing it.

---

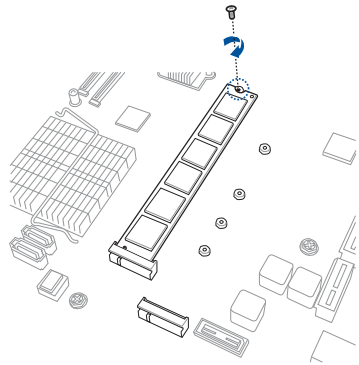

## 2.6 Cable connections



- The bundled system cables are pre-connected before shipment. You do not need to disconnect these cables unless you are going to remove pre-installed components to install additional devices.
- Refer to Chapter 4 for detailed information on the connectors.

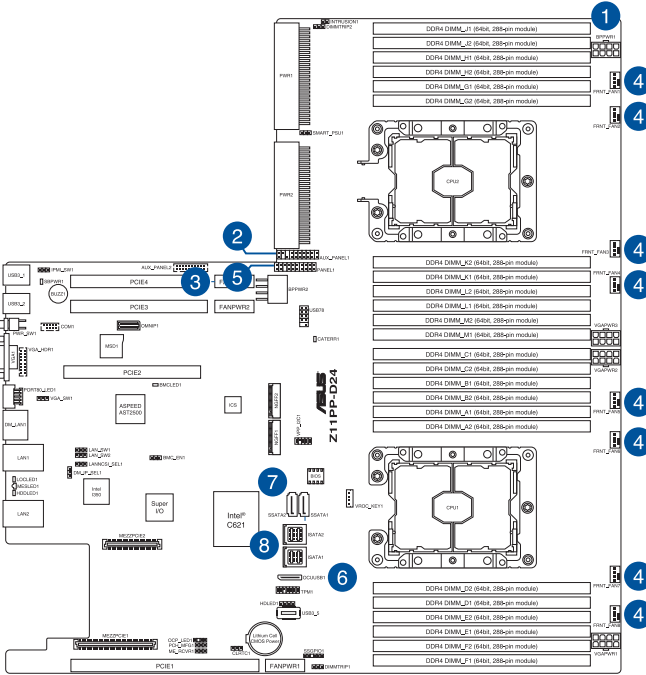

### Pre-connected system cables

1. 8-pin BPPWR1 power connector (from power supply to backplane)
2. Auxiliary panel 1 connector (from motherboard to front I/O board)
3. Auxiliary panel 2 connector (from motherboard to front I/O board)
4. System fan connectors (from motherboard FAN1-8 to system fans)
5. Panel connector (from motherboard to front I/O board)
6. OCU-USB to USB connector (from motherboard to front I/O board)
7. SATA connectors (from motherboard to SATA/SAS backplane board)
8. ISATA connectors (from motherboard to SATA/SAS backplane board)

## 2.7 SATA/SAS backplane cabling

RS720-E9-RS8 (without rear bay model)

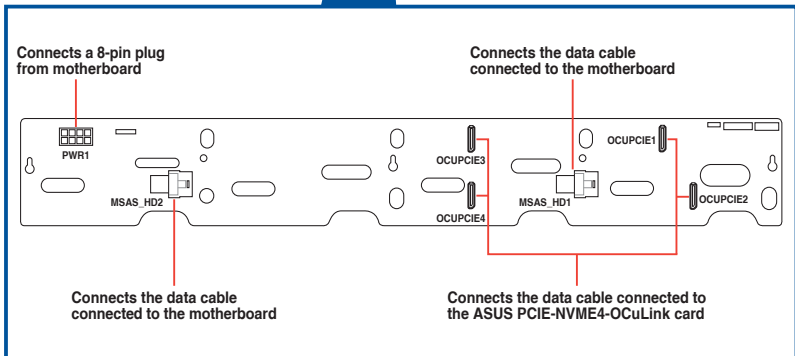
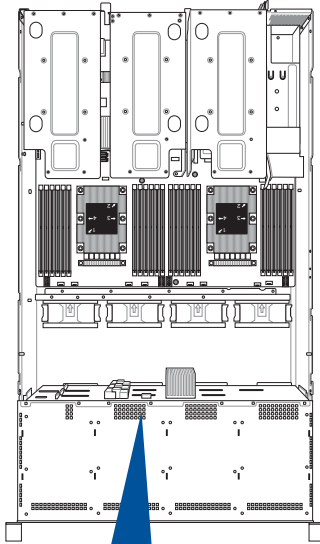

# RS720-E9-RS8 (with rear bay model)

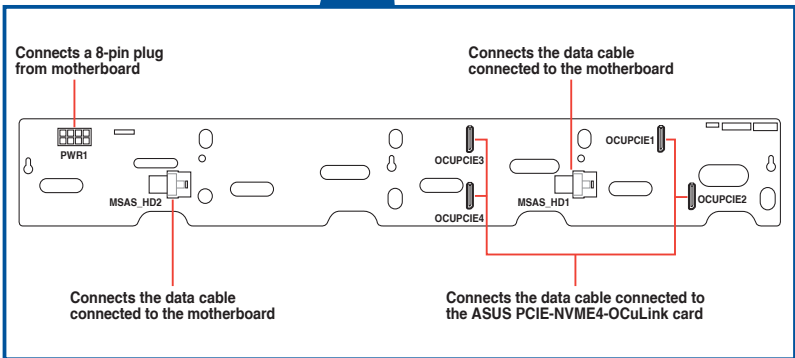
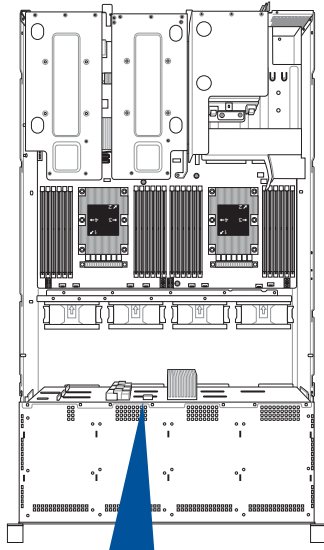

RS720-E9-RS8-G

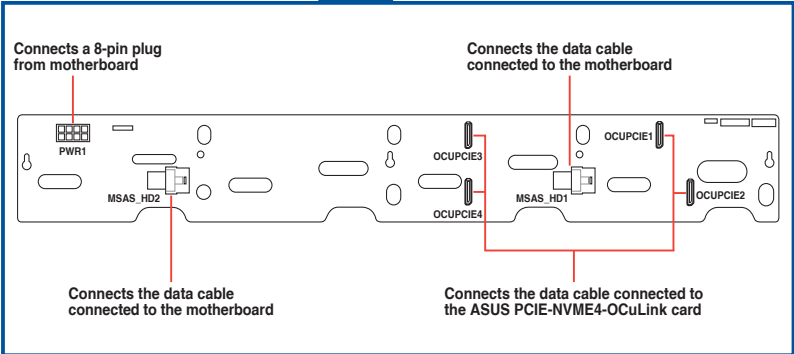
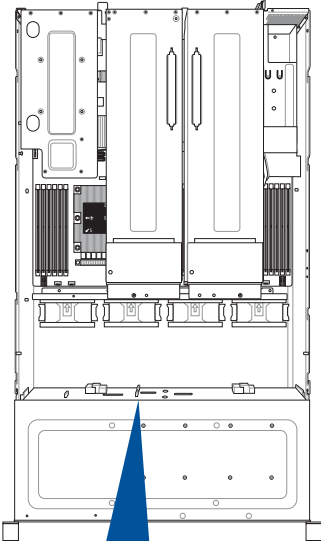

## 2.8 Removable/optional components

This section explains how to install optional components into the system and covers the following components:

1. System fans
2. Redundant power supply module



---

Ensure that the system is turned off before removing any components.

---



---

You may need to remove previously installed component or factory shipped components when installing optional components.

---

### 2.8.1 System fans

To remove the system fans:

1. Locate the fans you want to replace.
2. Press the retaining clip (A) and lift upward (B) to remove the fan.

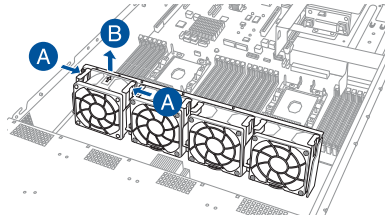

To reinstall the system fans:

1. Replace the fan with the same model and size.
4. Align and position the fan with the arrow on the fan pointing to the back of the chassis (C).
5. Install the fan to the fan cage.

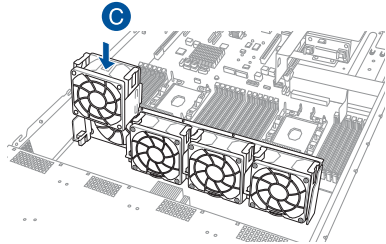

---

The fan can only be installed in one direction. If the fan cannot be installed, turn it around and try again.

---

## 2.8.2 Redundant power supply module

To replace a failed redundant power supply module:

1. Lift up the power supply module lever.
2. Hold the power supply module lever and press the PSU latch.
3. Pull the power supply module out of the system chassis.

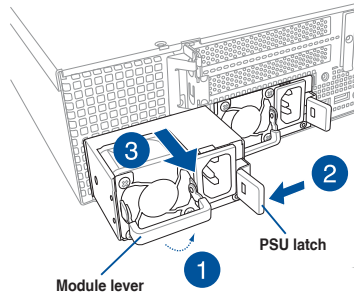

4. Insert the replacement power supply module into the chassis, then push it inwards until the latch locks into place.

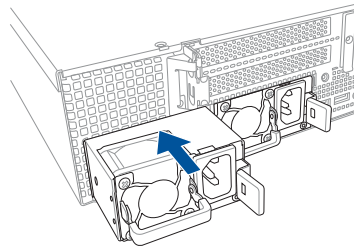



# Installation Options

# 3

This chapter describes how to install the optional components and devices into the barebone server.

### 3.1 Tool-less Friction Rail Kit

The tool less design of the rail kit allows you to easily install the rack rails into the server rack without the need for additional tools. The kit also comes with a metal stopping bracket that can be installed to provide additional support and stability to the server.

The tool-less rail kit package includes:

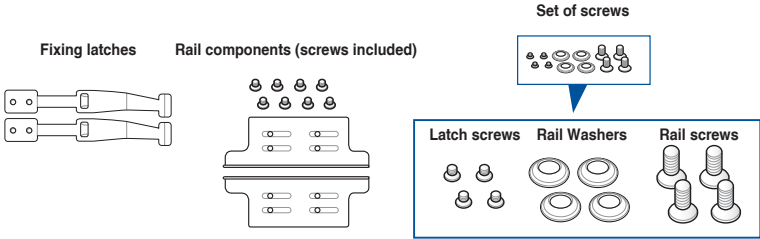

Tool-less rack rail

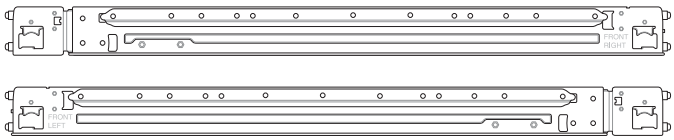

## 3.2 Installing the tool-less rack rail

To install the tool-less rack rails into the rack:

1. Secure the two fixing latches to the two sides of the server using the set of latch screws.



The locations of the screw holes vary with different server models. Refer to your server user manual for details.

### For 1U devices

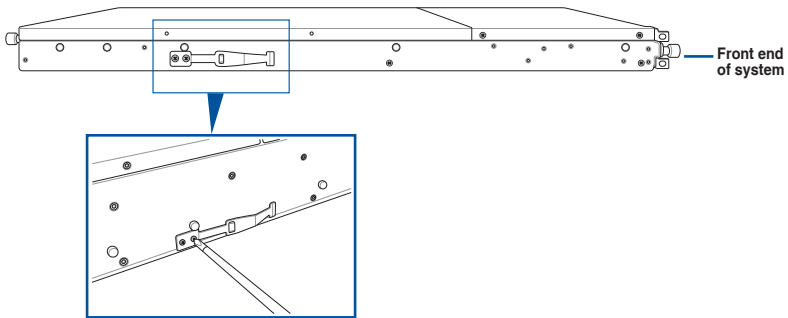

### For 2U devices

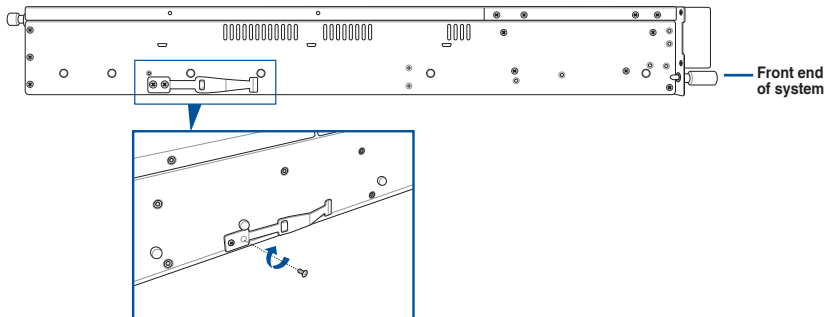



---

Follow steps 2 to 4 if the depth of your server rack exceeds 850mm, if the depth of your server rack is less than 850mm, please skip steps 2 to 4 and proceed with step 5.

---

2. Slightly slide out and extend the right rack rail, then prepare one of the bundled rail components.

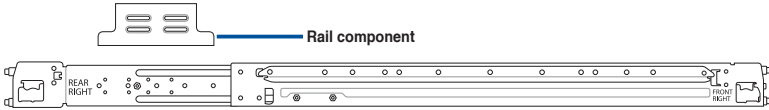

3. Align the rail component with the right rack rail and secure it using four (4) bundled screws.

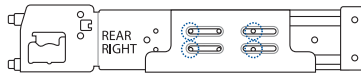

4. Follow steps 2 and 3 to secure the rail component to the left rail rack.
5. Select a desired space and place the appropriate rack rail (left and right) on opposite positions on the rack.



---

A 1U space consists of three square mounting holes with two thin lips on the top and the bottom.

---

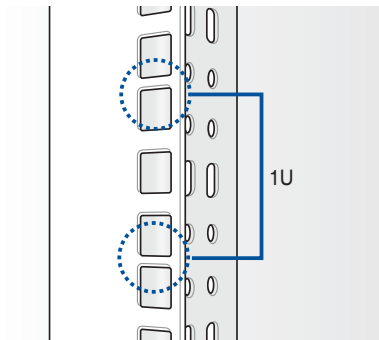

- Secure the rail components to the rail using the bundled screws.
- Press the spring lock (A) then insert the studs into the selected square mounting holes on the rack post.
- Press the spring lock on the other end of rail then insert the stud into the mounting hole on the rack post. Extend the rack rail, if necessary.
- (Optional) Use the rail screw and rail washer (B) that comes with the kit to secure the rack rail to the rack post.
- Perform steps 3 to 5 for the other rack rail.



---

Ensure that the installed rack rails (left and right) are aligned, secured, and stable in place.

---

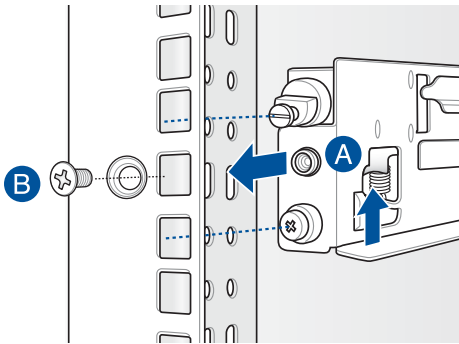

- Lift the server chassis and insert into the rack rail.



---

Ensure that the rack rail cabinet and the rack posts are stable and standing firmly on a level surface.

---

### 3.3 Rail kit dimensions

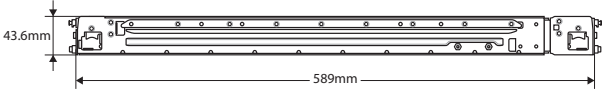
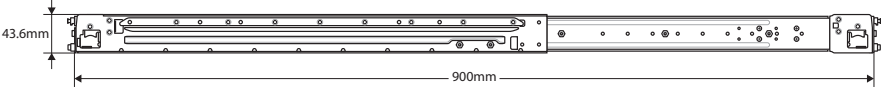

# Motherboard Information

# 4

This chapter includes the motherboard layout and brief descriptions of the jumpers and internal connectors.

# 4.1 Motherboard layout

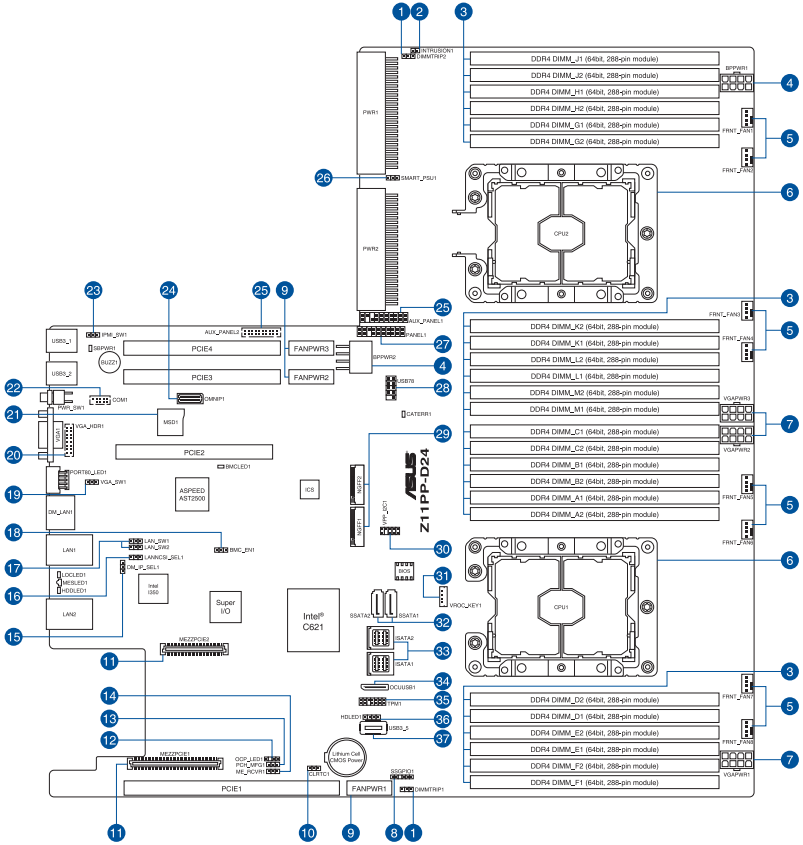

## Layout contents

Internal connectors / Sockets / Jumpers / LEDs	Page
1. DDR4 thermal event setting (3-pin DIMMTRIP1, DIMMTRIP2)	4-7
2. Chassis Intrusion (2-pin INTRUSION1)	4-20
3. DDR4 DIMM sockets	2-5
4. Back panel power connectors (8-pin BPPWR1-2)	4-19
5. System fan connectors (4-pin FAN1-8)	4-16
6. CPU socket	2-3
7. VGA power connectors (8-pin VGAPWR1-3)	4-19
8. Serial General Purpose Input/Output connector (6-1 pin SSGPIO1)	4-23
9. Fan power connectors (FANPWR1-3)	4-15
10. Clear RTC RAM (3-pin CLRTC1)	4-4
11. Mezzanine PCIe card connectors (MEZZPCIE1-2)	4-21
12. OCP LAN Activity LED connector (4-1 pin OCP_LED1)	4-24
13. PCH_MFG1 setting (3-pin PCH_MFG1)	4-7
14. ME firmware force recovery setting (3-pin ME_RCVR1)	4-6
15. DMLAN setting (3-pin DM_IP_SEL1)	4-8
16. LANNCSI setting (3-pin LANNCSI_SEL1)	4-9
17. LAN controller setting (3-pin LAN_SW1, LAN_SW2)	4-5
18. Baseboard Management Controller setting (3-pin BMC_EN1)	4-6
19. VGA controller setting (3-pin VGA_SW1)	4-5
20. VGA connector (16-pin VGA_HDR1)	4-20
21. Micro SD card slot (MSD1)	4-22
22. Serial port connector (10-1 pin COM1)	4-22
23. IPMI SW setting (3-pin IPMI_SW1)	4-9
24. OMNIP connector (24-pin OMNIP1)	4-24
25. Auxiliary panel connector (20-2 pin AUX_PANEL1, 20-pin AUX_PANEL2)	4-18
26. Smart Ride Through (Smart) setting (3-pin SMART_PSU1)	4-8
27. System panel connector (20-pin PANEL1)	4-17
28. USB 2.0 connector (10-1 pin USB78)	4-15
29. M.2 (NGFF) card connectors (NGFF1-2)	4-21
30. VPP_I2C1 connector (10-1 pin VPP_I2C1)	4-25
31. VROC_KEY connector (4-pin VROC_KEY)	4-23
32. Serial ATA connectors (7-pin SSATA1-2)	4-13
33. Mini-SAS HD connector (ISATA1-2)	4-13
34. USB 3.0 connectors (OCUUSB1)	4-25
35. TPM connector (20-1 pin TPM1)	4-16
36. Hard disk activity LED connector (4-pin HDLED1)	4-14
37. USB 3.0 connectors (Type A USB3_5)	4-14

## 4.2 Jumpers

### 1. Clear RTC RAM (3-pin CLRTC1)

This jumper allows you to clear the Real Time Clock (RTC) RAM in CMOS. You can clear the CMOS memory of date, time, and system setup parameters by erasing the CMOS RTC RAM data. The onboard button cell battery powers the RAM data in CMOS, which include system setup information such as system passwords.

To erase the RTC RAM:

1. Turn OFF the computer and unplug the power cord.
2. Move the jumper cap from pins 1–2 (default) to pins 2–3. Keep the cap on pins 2–3 for about 5–10 seconds, then move the cap back to pins 1–2.
3. Plug the power cord and turn ON the computer.
4. Hold down the <Del> key during the boot process and enter BIOS setup to re-enter data.



Except when clearing the RTC RAM, never remove the cap on CLRTC jumper default position. Removing the cap will cause system boot failure!



If the steps above do not help, remove the onboard battery and move the jumper again to clear the CMOS RTC RAM data. After the CMOS clearance, reinstall the battery.

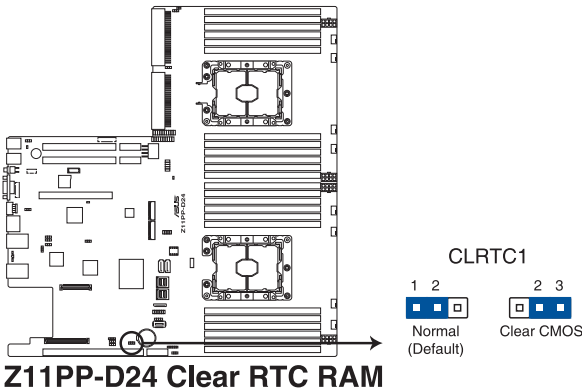

## 2. VGA controller setting (3-pin VGA\_SW1)

This jumper allows you to enable or disable the onboard VGA controller. Set to pins 1–2 to activate the VGA feature.

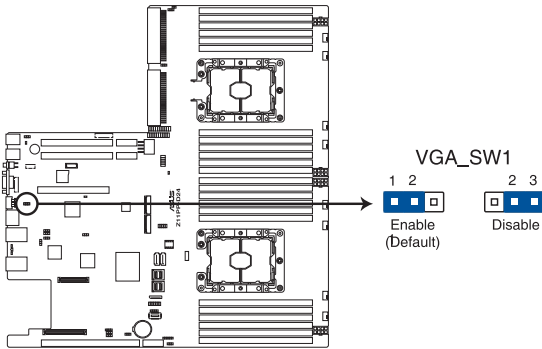

**Z11PP-D24 VGA setting**

## 3. LAN controller setting (3-pin LAN\_SW1, LAN\_SW2)

These jumpers allow you to enable or disable the onboard Intel® I350-AM2 Gigabit LAN/2 controller. Set to pins 1–2 to activate the Gigabit LAN feature.

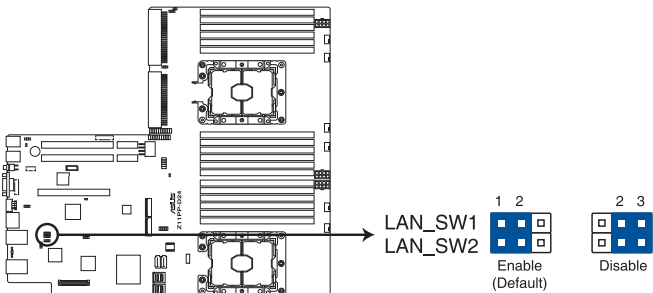

**Z11PP-D24 LAN setting**

**4. ME firmware force recovery setting (3-pin ME\_RCVR1)**

This jumper allows you to quickly recover the Intel Management Engine (ME) firmware when it becomes corrupted.

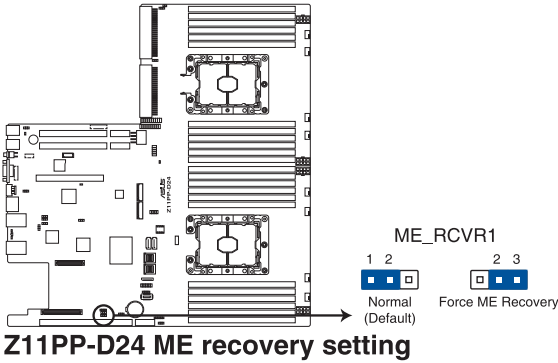

**5. Baseboard Management Controller setting (3-pin BMC\_EN1)**

This jumper allows you to enable (default) or disable on-board BMC. Ensure to set this BMC jumper to enabled to avoid system fan control and hardware monitor error.

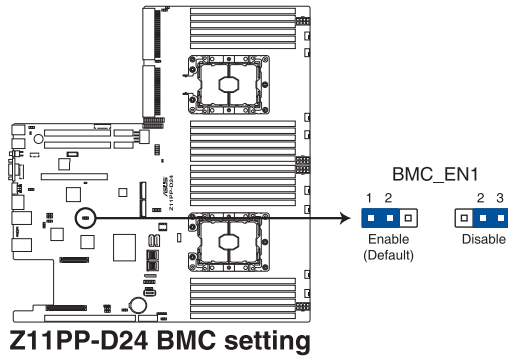

6. **DDR4 thermal event setting (3-pin DIMMTRIP1, DIMMTRIP2)**

This jumper allows you to enable or disable DDR4 DIMM thermal sensing event pin.

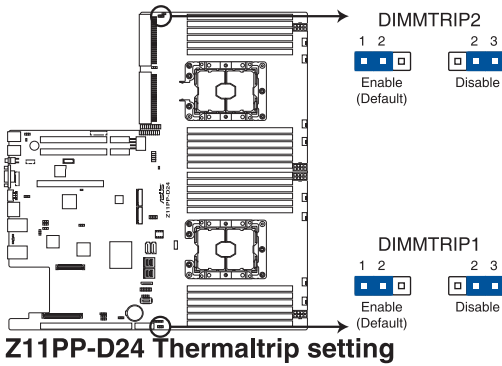

7. **PCH\_MFG1 setting (3-pin PCH\_MFG1)**

This jumper allows you to update the BIOS ME block.

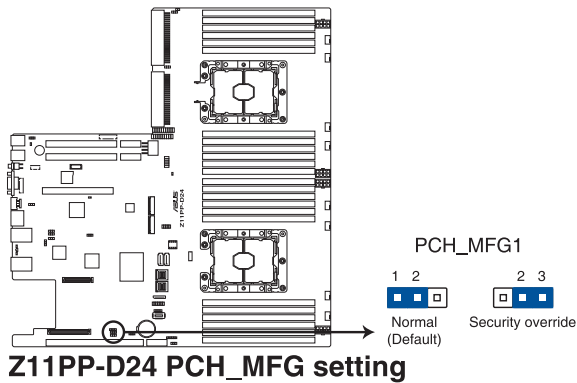

**8. Smart Ride Through (Smart) setting (3-pin SMART\_PSU1)**

This jumper allows you to enable or disable the Smart Ride Through (SmaRT) function. This feature is enabled by default. Set to pins 2-3 to disable it. When enabled, SmaRT allows uninterrupted operation of the system during an AC loss event.

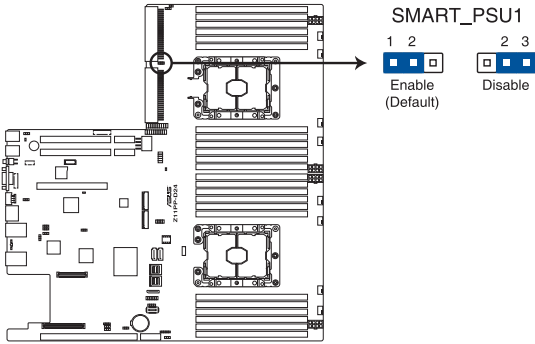

**Z11PP-D24 PMBus 1.2 PSU setting**

**9. DMLAN setting (3-pin DM\_IP\_SEL1)**

This jumper allows you to select the DMLAN setting. Set to pins 2-3 to force the DMLAN IP to static mode (IP=10.10.10.10, submask=255.255.255.0).

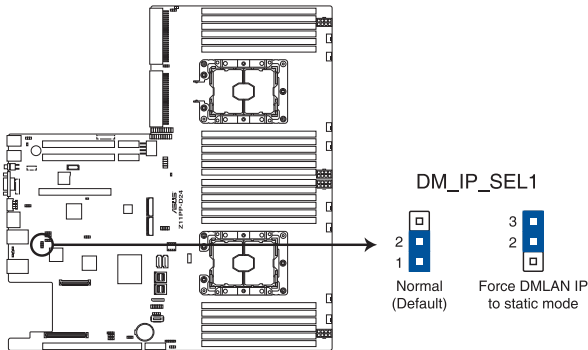

**Z11PP-D24 DM\_IP\_SEL1 setting**

### 10. LANNCSE setting (3-pin LANNCSE\_SEL1)

This jumper allows you to select which LAN NCSE to function.

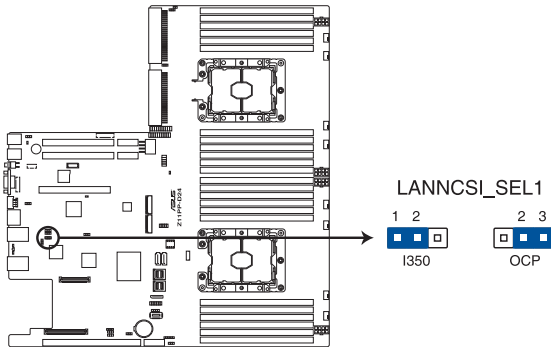

**Z11PP-D24 LANNCSE\_SEL1 setting**

### 11. IPMI SW setting (3-pin IPMI\_SW1)

This jumper allows you to select which protocol in the GPU sensor to function.

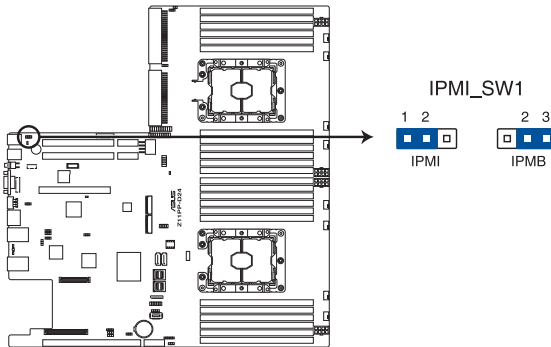

**Z11PP-D24 IPMI\_SW1 setting**

## 4.3 Internal LEDs

### 1. Standby Power LED (SBPWR1)

The motherboard comes with a standby power LED. The green LED lights up to indicate that the system is ON, in sleep mode, or in soft-off mode. This is a reminder that you should shut down the system and unplug the power cable before removing or plugging in any motherboard component. The illustration below shows the location of the onboard LED.

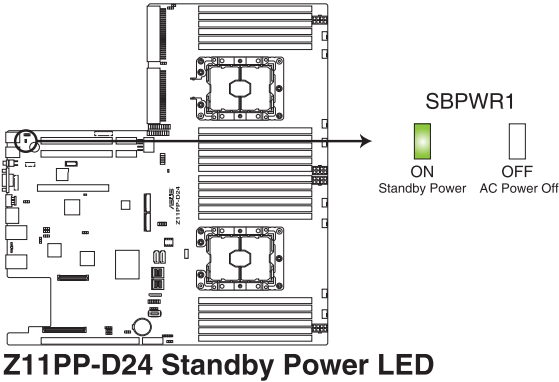

### 2. Location LED (LOCLED1)

This onboard LED lights up when the Location button on the server is pressed or when triggered by a system management software. The Location LED helps visually locate and quickly identify the server in error on a server rack.

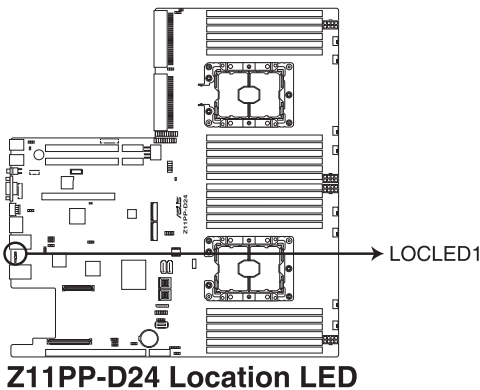

### 3. Hard disk activity LED (HDDLED1)

This LED is for the storage devices connected to the onboard SATA, or SATA/SAS add-on card. The read or write activities of any device connected to the onboard SATA, or SATA/SAS add-on card causes the rear panel LED to light up.

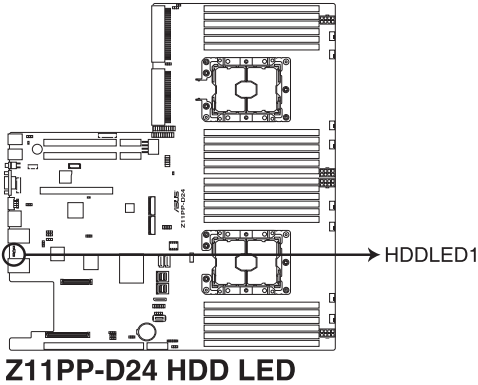

### 4. Message LED (MESLED1)

This onboard LED lights up to red when there is a BMC event log is generated.

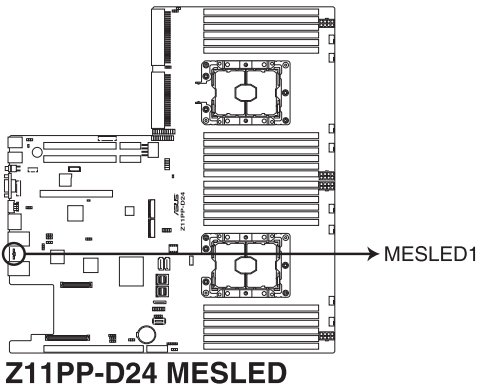

**5. BMC LED (BMCLD1)**

The BMC LED lights up to indicate that the on-board BMC is functional.

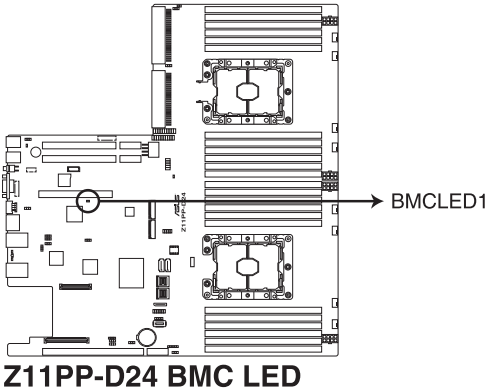

**6. CATT LED (CATTERR1)**

The CATT LED indicates that the system has experienced a fatal or catastrophic error and cannot continue to operate.

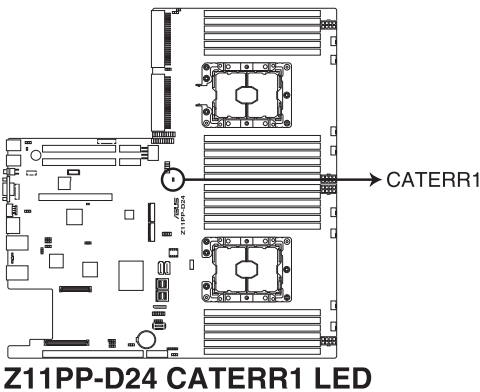

## 4.4 Internal connectors

### 1. Serial ATA connectors (7-pin SSATA1-2)

These connectors, controlled by Intel® C621 chipset, are for the Serial ATA signal cables for Serial ATA hard disk drives (SATA 1 connector is used for the optical drive by default).



If the SATA M.2 (NGFF1) slot is occupied, the SSATA2 slot will be disabled.

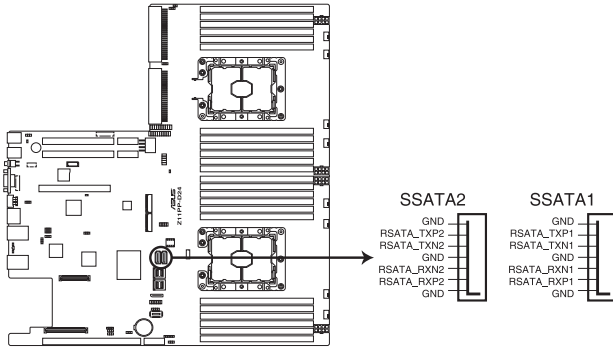

**Z11PP-D24 SSATA connectors**

### 2. Mini-SAS HD connector (ISATA1-2)

This motherboard comes with mini Serial Attached SCSI (SAS) HD connectors, the storage technology that supports Serial ATA. Each connector supports up to four devices.

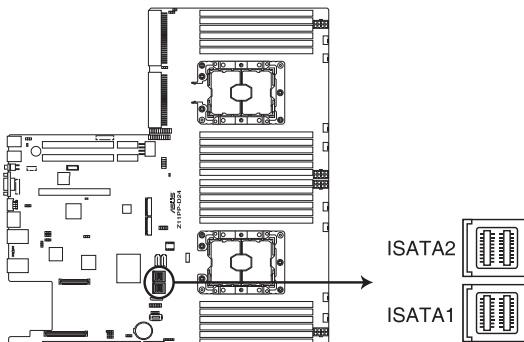

**Z11PP-D24 ISATA connectors**

**3. USB 3.0 connectors (Type A USB3\_5)**

The USB3\_5 connector is for Type-A USB 3.0 devices. You can enjoy all the benefits of USB 3.0 including faster data transfer speeds of up to 5 Gbps, faster charging time for USB-chargeable devices, optimized power efficiency, and backward compatibility with USB 2.0.

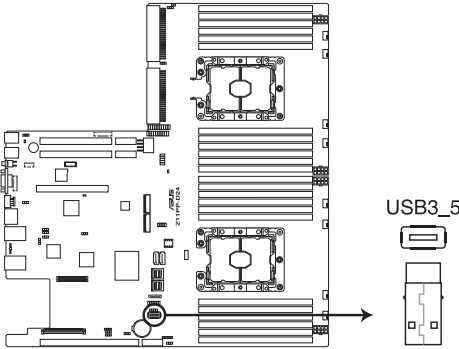

**Z11PP-D24 USB 3.0 connector**

**4. Hard disk activity LED connector (4-pin HDLED1)**

This LED connector is for the storage add-on card cable connected to the SATA or SAS add-on card. The read or write activities of any device connected to the SATA or SAS add-on card causes the front panel LED to light up.

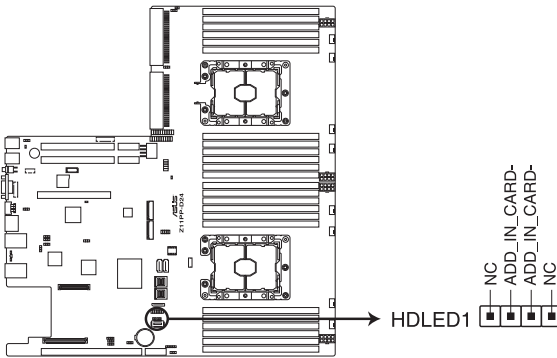

**Z11PP-D24 Hard disk activity LED connector**

**5. USB 2.0 connector (10-1 pin USB78)**

This connector is for USB 2.0 ports. Connect the USB module cable to the connector, and then install the module to a slot opening at the back of the system chassis. The USB connectors comply with USB 2.0 specification that supports up to 480 Mbps connection speed.

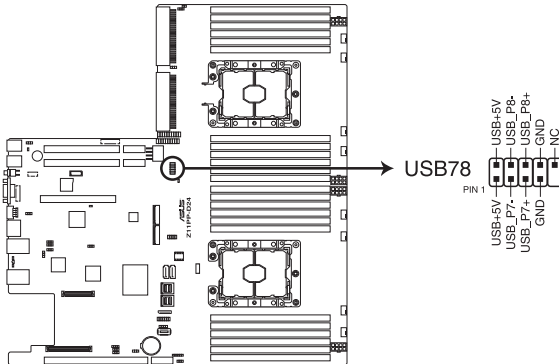

**Z11PP-D24 USB 2.0 connector**



The USB port module is purchased separately.

**6. Fan power connectors (FANPWR1-3)**

These connectors are for the power supply plugs that connects to additional fans. The power supply plugs are designed to fit these connectors in only one orientation. Find the proper orientation and push down firmly until the connectors completely fit.

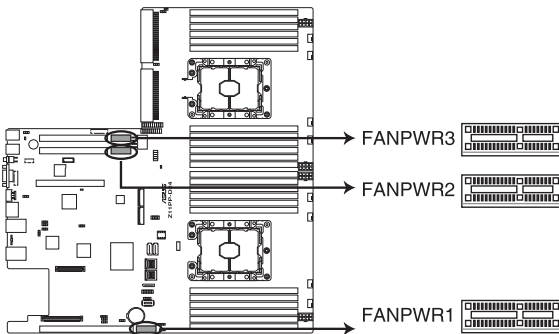

**Z11PP-D24 FANPWR**

### 7. System fan connectors (4-pin FAN1-8)

The fan connectors support cooling fans of 0.8A–1.0A (12 W max.) or a total of 6.4 A–8.0 A (96 W max.) at +12V. Connect the fan cables to the fan connectors on the motherboard, making sure that the black wire of each cable matches the ground pin of the connector.



DO NOT forget to connect the fan cables to the fan connectors. Insufficient air flow inside the system may damage the motherboard components. These are not jumpers! DO NOT place jumper caps on the fan connectors!

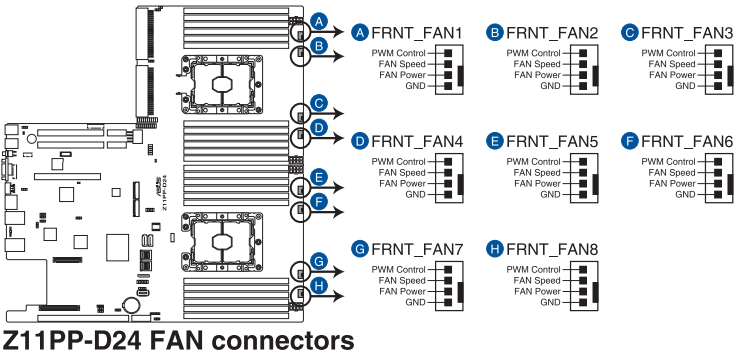

### 8. TPM connector (20-pin TPM1)

This connector supports a Trusted Platform Module (TPM) system, which can securely store keys, digital certificates, passwords, and data. A TPM system also helps enhance network security, protects digital identities, and ensures platform integrity.

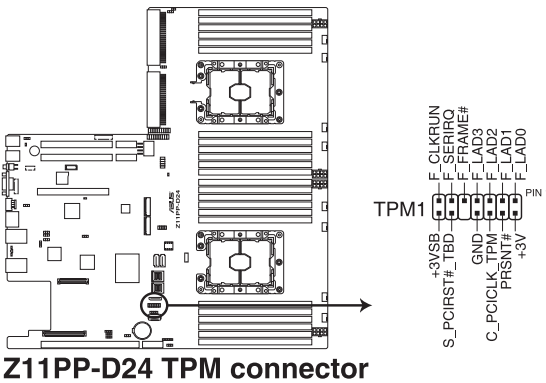

## 9. System panel connector (20-pin PANEL1)

This connector supports several chassis-mounted functions.

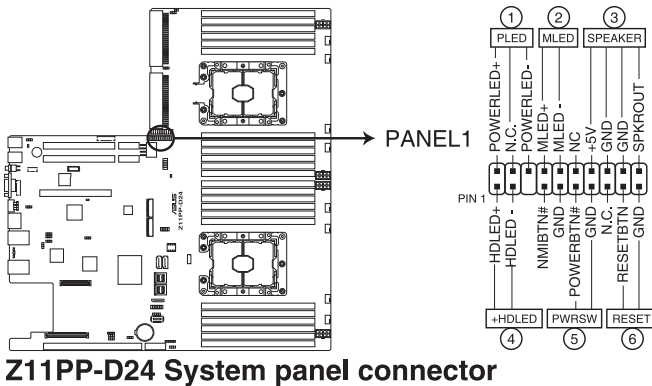

### 1. System power LED (3-pin PLED)

This 3-pin connector is for the system power LED. Connect the chassis power LED cable to this connector. The system power LED lights up when you turn on the system power, and blinks when the system is in sleep mode.

### 2. Message LED (2-pin MLED)

This 2-pin connector is for the message LED cable that connects to the front message LED. The message LED is controlled by the BMC to indicate an abnormal event occurrence.

### 3. System warning speaker (4-pin SPEAKER)

This 4-pin connector is for the chassis-mounted system warning speaker. The speaker allows you to hear system beeps and warnings.

### 4. Hard disk drive activity LED (2-pin HDLED)

This 2-pin connector is for the HDD Activity LED. Connect the HDD Activity LED cable to this connector. The LED lights up or flashes when data is read from or written to the HDD.

### 5. ATX power button/soft-off button (2-pin PWRSW)

This connector is for the system power button. Pressing the power button turns the system on or puts the system in sleep or soft-off mode depending on the BIOS settings. Pressing the power switch for more than four seconds while the system is ON turns the system OFF.

### 6. Reset button (2-pin RESET)

This 2-pin connector is for the chassis-mounted reset button for system reboot without turning off the system power.

## 10. Auxiliary panel connector (20-2 pin AUX\_PANEL1, 20-pin AUX\_PANEL2)

This connector is for additional front panel features including front panel SMB, locator LED and switch, chassis intrusion, and LAN LEDs.

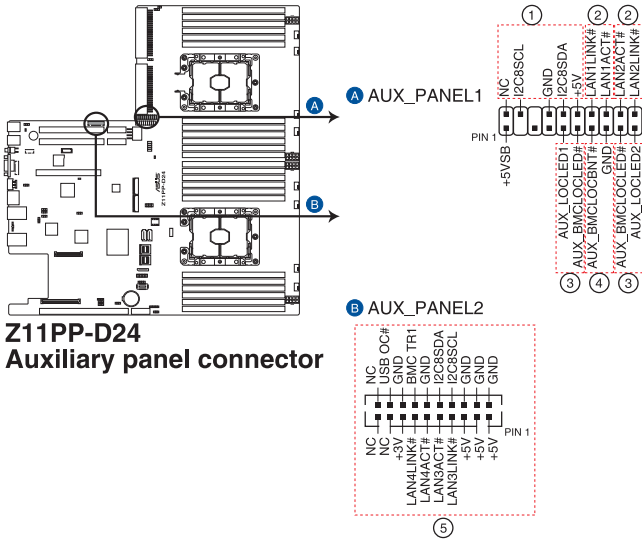

### 1. Front panel SMB (6-1 pin FPSMB)

These leads connect the front panel SMBus cable.

### 2. LAN activity LED (2-pin LAN1\_LED, LAN2\_LED)

These leads are for the Gigabit LAN activity LEDs on the front panel.

### 3. Locator LED (2-pin LOCATORLED1, 2-pin LOCATORLED2)

These leads are for the locator LED1 and LED2 on the front panel. Connect the Locator LED cables to these 2-pin connector. The LEDs will light up when the Locator button is pressed.

### 4. Locator Button/Switch (2-pin LOCATORBTN)

These leads are for the locator button on the front panel. This button queries the state of the system locator.

### 5. LAN activity LED and USB port (2-pin LAN3\_LED, LAN4\_LED, USB ports)

These leads are for the Gigabit LAN activity LEDs and USB ports on the front panel.

## 11. Back panel power connectors (8-pin BPPWR1-2)

These connectors are for the power supply plugs that connects to the back panel. The power supply plugs are designed to fit these connectors in only one orientation. Find the proper orientation and push down firmly until the connectors completely fit.

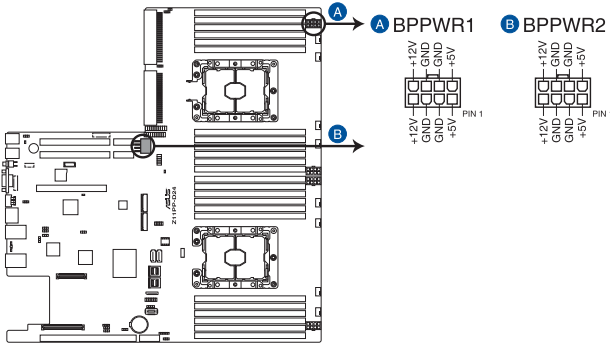

### Z11PP-D24 BP power connectors



DO NOT connect VGA cards to these connectors. Doing so may cause system boot errors and permanent damage to your motherboard or device.

## 12. VGA power connectors (8-pin VGAPWR1-3)

These connectors are for the power supply plugs that connects to the VGA card. The power supply plugs are designed to fit these connectors in only one orientation. Find the proper orientation and push down firmly until the connectors completely fit.

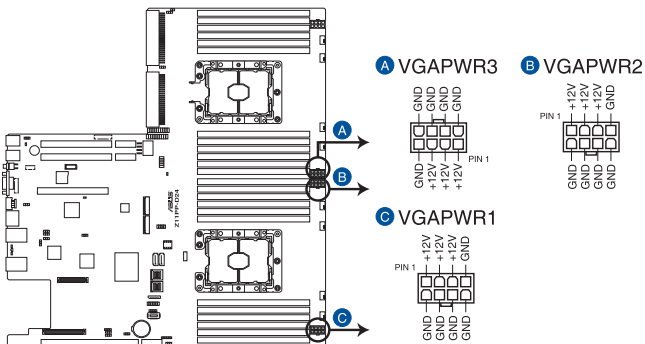

### Z11PP-D24 VGA power connectors



DO NOT connect the back panel to these connectors. Doing so may cause system boot errors and permanent damage to your motherboard or device.

**13. VGA connector (16-pin VGA\_HDR1)**

This connector supports the VGA High Dynamic-Range interface.

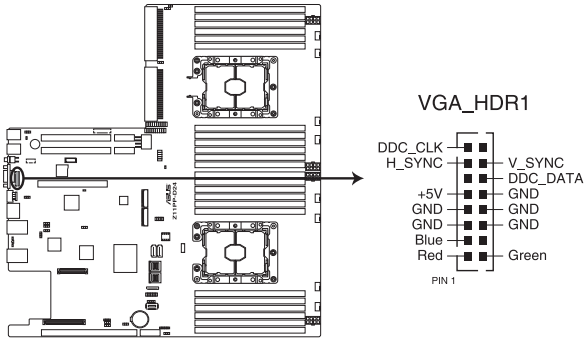

**Z11PP-D24 Internal VGA connector**

**14. Chassis Intrusion (2-pin INTRUSION1)**

These leads are for the intrusion detection feature for chassis with intrusion sensor or microswitch. When you remove any chassis component, the sensor triggers and sends a high level signal to these leads to record a chassis intrusion event. The default setting is to short the CHASSIS# and the GND pin by a jumper cap to disable the function.

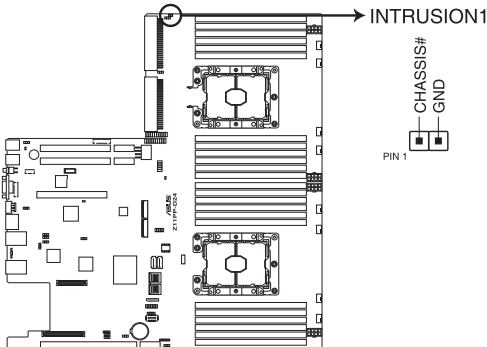

**Z11PP-D24 Chassis Intrusion connector**

### 15. Mezzanine PCIe card connectors (MEZZPCIE1-2)

The MEZZPCIE1-2 connector supports Open Compute Project (OCP) cards.

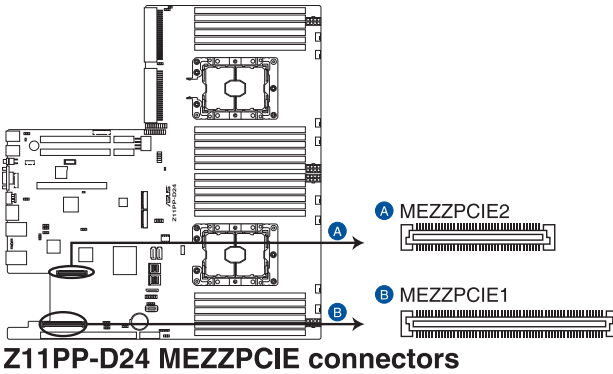

### 16. M.2 (NGFF) card connectors (NGFF1-2)

These connectors allow you to install M.2 devices.

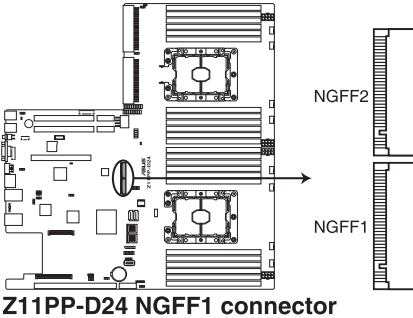

- This connector supports type 2242 / 2260 / 2280 / 22110 devices on both PCI-E and SATA interface.
- If the SATA M.2 (NGFF1) slot is occupied, the SSATA2 slot will be disabled.



The M.2 (NGFF) device is purchased separately

**17. Serial port connector (10-1 pin COM1)**

This connector is for a serial (COM) port. Connect the serial port module cable to this connector, then install the module to a slot opening at the back of the system chassis.

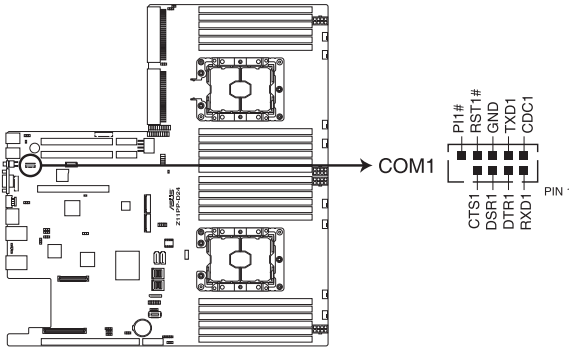

**Z11PP-D24 Serial port connector**



The COM module is purchased separately.

**18. Micro SD card slot (MSD1)**

Your motherboard supports SD Memory Card v2.00 (SDHC) / v3.00 (SDXC).

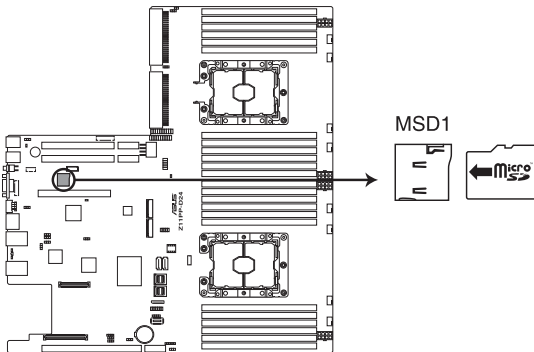

**Z11PP-D24 MSD1**



Disconnect all power (including redundant PSUs) from the existing system before you add or remove a Memory Card, then reboot the system to access the Memory Card.



Some memory cards may not be compatible with your motherboard. Ensure that you use only compatible memory cards to prevent loss of data, damage to your device, or memory card, or both.

### 19. VROC\_KEY connector (4-pin VROC\_KEY)

This connector allows you to connect a KEY module to support Intel VMD RAID function.

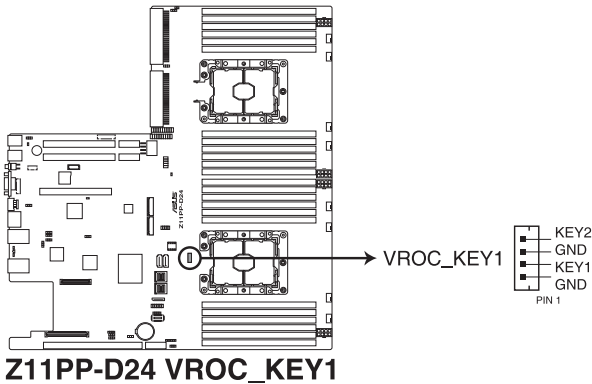

### 20. Serial General Purpose Input/Output connector (6-pin SSGPIO1)

The SSGPIO 1 connector is used for the Intel Rapid Storage Technology Enterprise SGPIO interface that controls the LED pattern generation, device information, and general purpose data.

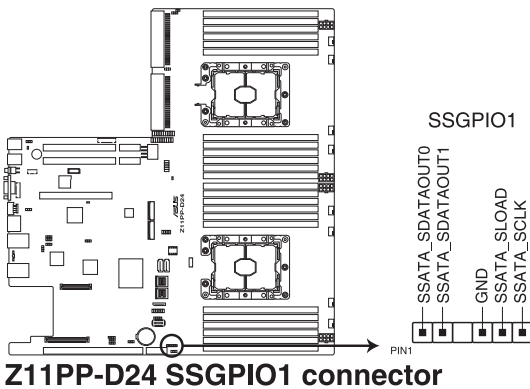

**21. OCP LAN Activity LED connector (4-1 pin OCP\_LED1)**

OCP LAN LED connector supports OCP LAN card Active LED.

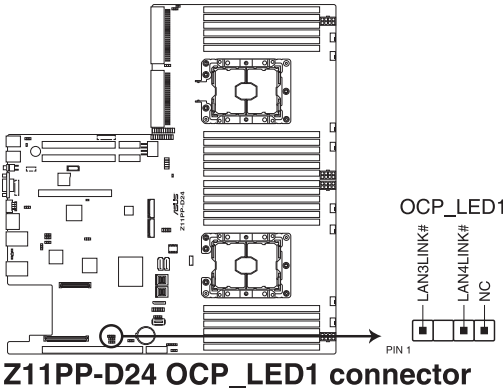

**22. OMNIP connector (24-pin OMNIP1)**

This connector allows you to provide sideband signals from the fabric CPU to a HFI-OMNI supported ASUS card.

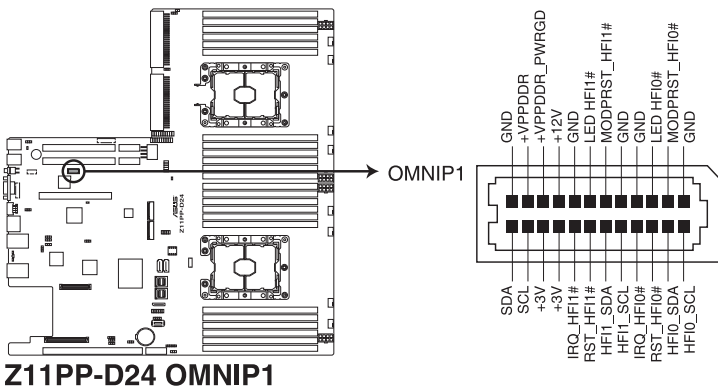

### 23. VPP\_I2C1 connector (10-1 pin VPP\_I2C1)

This connector is used for the Intel VMD function and sensor readings.

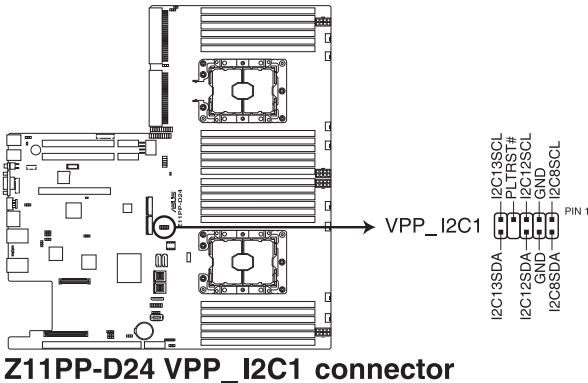

### 24. USB 3.0 connectors (OCUUSB1)

Connect a compatible USB module cable to the OCUUSB1 connector, and then install the module to a slot opening at the back or front of the system chassis. You can enjoy all the benefits of USB 3.0 including faster data transfer speeds of up to 5 Gbps, faster charging time for USB-chargable devices, optimized power efficiency, and backward compatibility with USB 2.0. (OCUUSB1 connector is used for the front USB panel by default).

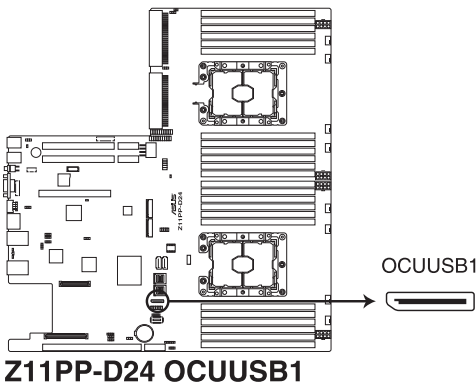

The USB port module is purchased separately.



# **BIOS Setup**

# 5

This chapter tells how to change the system settings through the BIOS Setup menus. Detailed descriptions of the BIOS parameters are also provided.

## 5.1 Managing and updating your BIOS

The following utilities allow you to manage and update the motherboard Basic Input/Output System (BIOS) setup:

### 1. **ASUS CrashFree BIOS 3**

To recover the BIOS using a bootable USB flash disk drive when the BIOS file fails or gets corrupted.

### 2. **ASUS EzFlash**

Updates the BIOS using a USB flash disk.

### 3. **BUPDATER**

Updates the BIOS in DOS mode using a bootable USB flash disk drive.

Refer to the corresponding sections for details on these utilities.



---

Save a copy of the original motherboard BIOS file to a bootable USB flash disk drive in case you need to restore the BIOS in the future. Copy the original motherboard BIOS using the BUPDATER utility.

---

### 5.1.1 **ASUS CrashFree BIOS 3 utility**

The ASUS CrashFree BIOS 3 is an auto recovery tool that allows you to restore the BIOS file when it fails or gets corrupted during the updating process. You can update a corrupted BIOS file using a USB flash drive that contains the updated BIOS file.



---

Prepare a USB flash drive containing the updated motherboard BIOS before using this utility.

---

### **Recovering the BIOS from a USB flash drive**

To recover the BIOS from a USB flash drive:

1. Insert the USB flash drive with the original or updated BIOS file to one USB port on the system.
2. The utility will automatically recover the BIOS. It resets the system when the BIOS recovery finished.



---

**DO NOT** shut down or reset the system while recovering the BIOS! Doing so would cause system boot failure!

---



---

The recovered BIOS may not be the latest BIOS version for this motherboard. Visit the ASUS website at [www.asus.com](http://www.asus.com) to download the latest BIOS file.

---

## 5.1.2 ASUS EZ Flash Utility

The ASUS EZ Flash Utility feature allows you to update the BIOS without having to use a DOS-based utility.



Before you start using this utility, download the latest BIOS from the ASUS website at [www.asus.com](http://www.asus.com).

To update the BIOS using EZ Flash Utility:

1. Insert the USB flash disk that contains the latest BIOS file into the USB port.
2. Enter the BIOS setup program. Go to the **Tool** menu then select **ASUS EZ Flash Utility**. Press <Enter>.

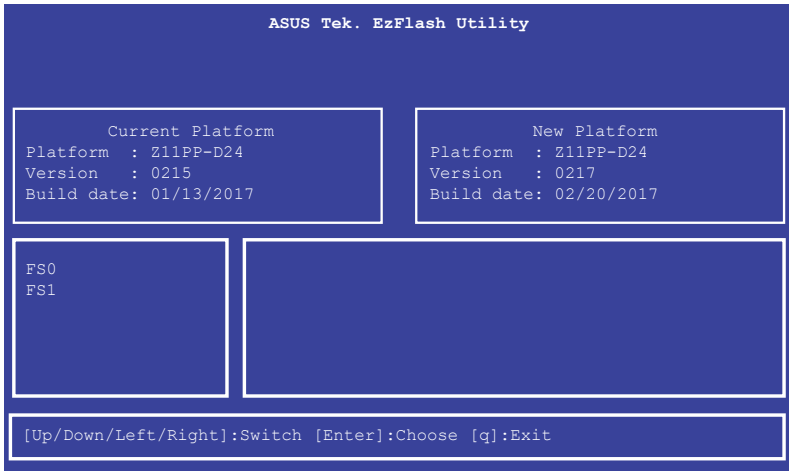

3. Press <Tab> to switch to the **Drive** field.
4. Press the Up/Down arrow keys to find the USB flash disk that contains the latest BIOS, then press <Enter>.
5. Press <Tab> to switch to the **Folder Info** field.
6. Press the Up/Down arrow keys to find the BIOS file, and then press <Enter> to perform the BIOS update process. Reboot the system when the update process is done.



- This function can support devices such as a USB flash disk with FAT 32/16 format and single partition only.
- DO NOT shut down or reset the system while updating the BIOS to prevent system boot failure!



Ensure to load the BIOS default settings to ensure system compatibility and stability. Press <F5> and select **Yes** to load the BIOS default settings.

### 5.1.3 BUPDATER utility



---

The succeeding BIOS screens are for reference only. The actual BIOS screen displays may not be the same as shown.

---

The BUPDATER utility allows you to update the BIOS file in the DOS environment using a bootable USB flash disk drive with the updated BIOS file.

#### Updating the BIOS file

To update the BIOS file using the BUPDATER utility:

1. Visit the ASUS website at [www.asus.com](http://www.asus.com) and download the latest BIOS file for the motherboard. Save the BIOS file to a bootable USB flash disk drive.
2. Copy the BUPDATER utility (BUPDATER.exe) from the ASUS support website at [www.asus.com/support](http://www.asus.com/support) to the bootable USB flash disk drive you created earlier.
3. Boot the system in DOS mode, then at the prompt, type:

```
BUPDATER /i [filename] .CAP
```

where [filename] is the latest or the original BIOS file on the bootable USB flash disk drive, then press <Enter>.

```
A:\>BUPDATER /i[file name].CAP
```

- The utility verifies the file, then starts updating the BIOS file.

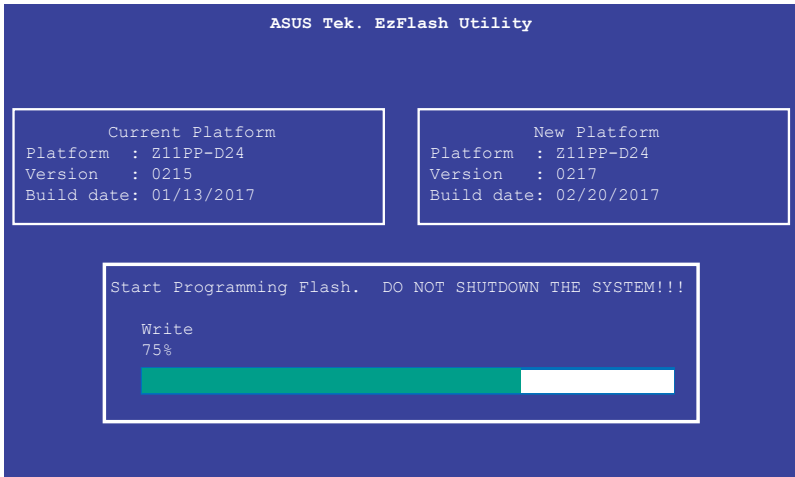

---

DO NOT shut down or reset the system while updating the BIOS to prevent system boot failure!

---

- The utility returns to the DOS prompt after the BIOS update process is completed. Reboot the system from the hard disk drive.

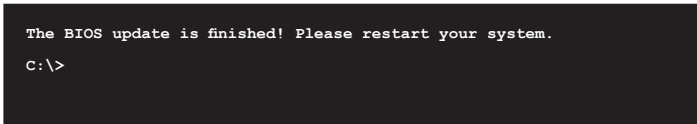

## 5.2 BIOS setup program

This motherboard supports a programmable firmware chip that you can update using the provided utility described in section **5.1 Managing and updating your BIOS**.

Use the BIOS Setup program when you are installing a motherboard, reconfiguring your system, or prompted to “Run Setup.” This section explains how to configure your system using this utility.

Even if you are not prompted to use the Setup program, you can change the configuration of your computer in the future. For example, you can enable the security password feature or change the power management settings. This requires you to reconfigure your system using the BIOS Setup program so that the computer can recognize these changes and record them in the CMOS RAM of the firmware chip.

The firmware chip on the motherboard stores the Setup utility. When you start up the computer, the system provides you with the opportunity to run this program. Press <Del> during the Power-On Self-Test (POST) to enter the Setup utility; otherwise, POST continues with its test routines.

If you wish to enter Setup after POST, restart the system by pressing <Ctrl>+<Alt>+<Delete>, or by pressing the reset button on the system chassis. You can also restart by turning the system off and then back on. Do this last option only if the first two failed.

The Setup program is designed to make it as easy to use as possible. Being a menu-driven program, it lets you scroll through the various sub-menus and make your selections from the available options using the navigation keys.



- 
- The default BIOS settings for this motherboard apply for most conditions to ensure optimum performance. If the system becomes unstable after changing any BIOS settings, load the default settings to ensure system compatibility and stability. Press <F5> and select **Yes** to load the BIOS default settings.
  - The BIOS setup screens shown in this section are for reference purposes only, and may not exactly match what you see on your screen.
  - Visit the ASUS website ([www.asus.com](http://www.asus.com)) to download the latest BIOS file for this motherboard.
-

## 5.2.1 BIOS menu screen

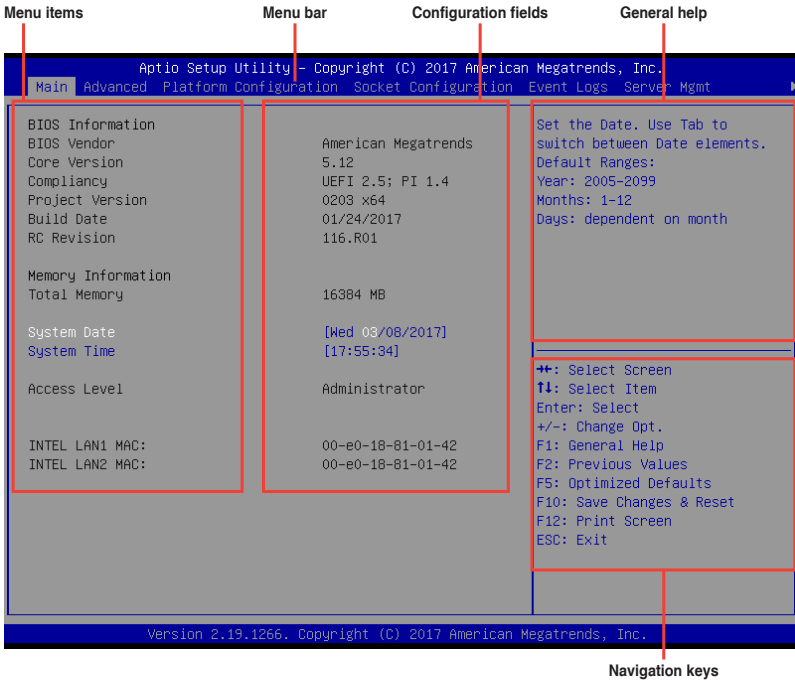

Navigation keys

## 5.2.2 Menu bar

The menu bar on top of the screen has the following main items:

<b>Main</b>	For changing the basic system configuration
<b>Advanced</b>	For changing the advanced system settings
<b>Platform Configuration</b>	For changing the platform settings
<b>Socket Configuration</b>	For changing the socket settings
<b>Event Logs</b>	For changing the event log settings
<b>Server Mgmt</b>	For changing the Server Mgmt settings
<b>Security</b>	For changing the security settings
<b>Boot</b>	For changing the system boot configuration
<b>Tool</b>	For configuring options for special functions
<b>Save &amp; Exit</b>	For selecting the exit options

To select an item on the menu bar, press the right or left arrow key on the keyboard until the desired item is highlighted.

### **5.2.3 Menu items**

The highlighted item on the menu bar displays the specific items for that menu. For example, selecting **Main** shows the Main menu items.

The other items (such as **Advanced**) on the menu bar have their respective menu items.

### **5.2.4 Submenu items**

A solid triangle before each item on any menu screen means that the item has a submenu. To display the submenu, select the item then press <Enter>.

### **5.2.5 Navigation keys**

At the bottom right corner of a menu screen are the navigation keys for the BIOS setup program. Use the navigation keys to select items in the menu and change the settings.

### **5.2.6 General help**

At the top right corner of the menu screen is a brief description of the selected item.

### **5.2.7 Configuration fields**

These fields show the values for the menu items. If an item is user-configurable, you can change the value of the field opposite the item. You cannot select an item that is not user-configurable.

A configurable field is enclosed in brackets, and is highlighted when selected. To change the value of a field, select it and press <Enter> to display a list of options.

### **5.2.8 Pop-up window**

Select a menu item and press <Enter> to display a pop-up window with the configuration options for that item.

### **5.2.9 Scroll bar**

A scroll bar appears on the right side of a menu screen when there are items that do not fit on the screen. Press the Up/Down arrow keys or <Page Up> / <Page Down> keys to display the other items on the screen.

## 5.3 Main menu

When you enter the BIOS Setup program, the Main menu screen appears. The Main menu provides you an overview of the basic system information, and allows you to set the system date, time, language, and security settings.

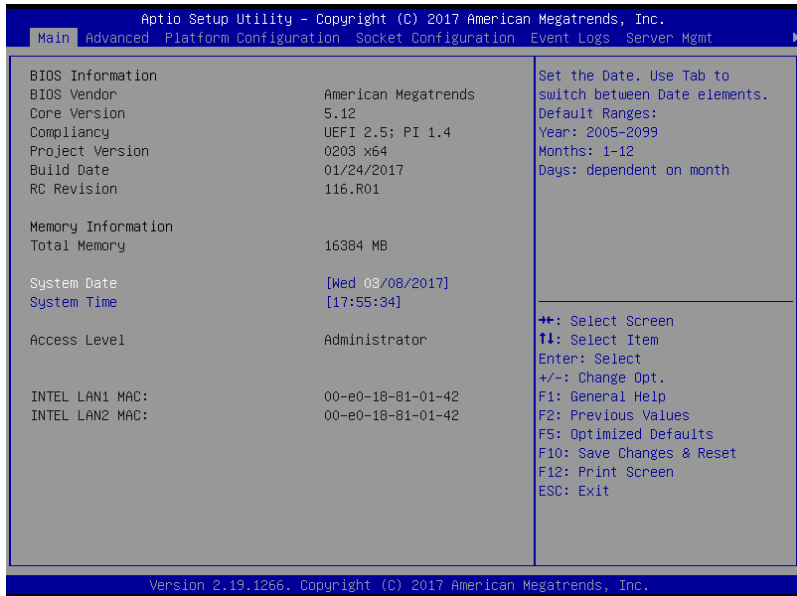

### 5.3.1 System Date [Day xx/xx/xxxx]

Allows you to set the system date.

### 5.3.2 System Time [xx:xx:xx]

Allows you to set the system time.

# 5.4 Advanced menu

The Advanced menu items allow you to change the settings for the CPU and other system devices.



Take caution when changing the settings of the Advanced menu items. Incorrect field values can cause the system to malfunction.

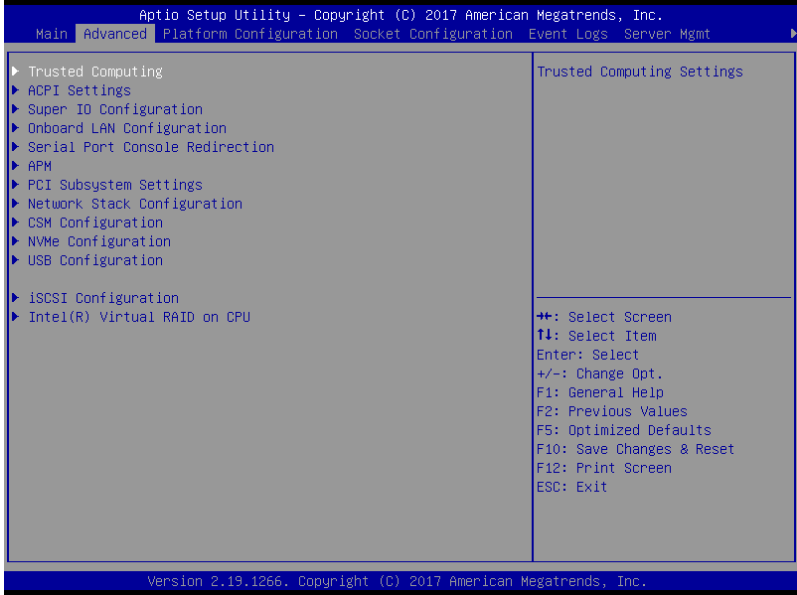

## 5.4.1 Trusted Computing

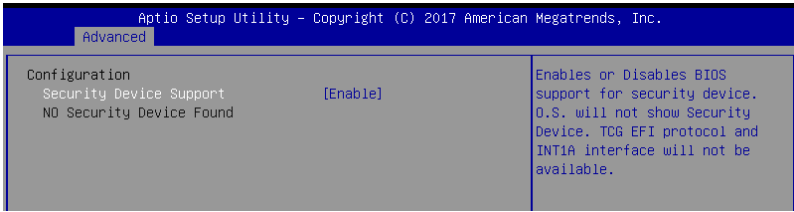

### Configuration

#### Security Device Support [Disabled]

Allows you to enable or disable the BIOS support for security device.

Configuration options: [Disabled] [Enabled]

## 5.4.2 ACPI Settings

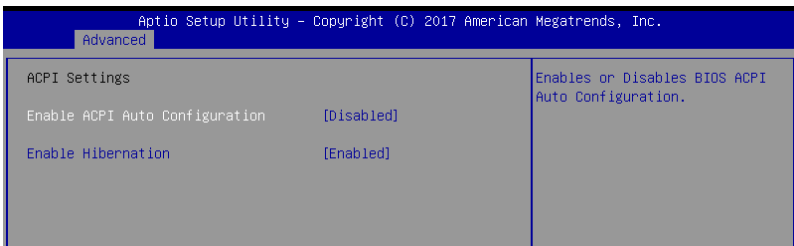

#### Enable ACPI Auto Configuration [Disabled]

Allows you to enable or disable the BIOS ACPI Auto Configuration.

Configuration options: [Disabled] [Enabled]

#### Enable Hibernation [Enabled]

Allows you to enable or disable the ability of the system to hibernate (OS/Sleep State).

Configuration options: [Disabled] [Enabled]



This option may be not effective with some OS.

## 5.4.3 Super IO Configuration

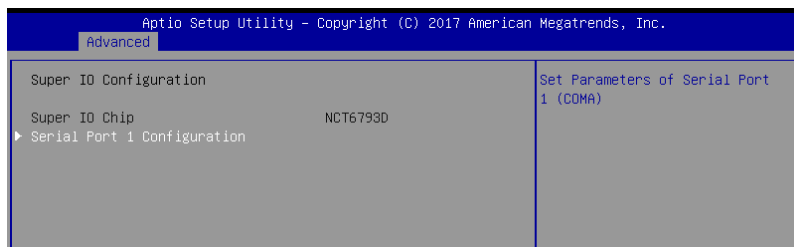

### Serial Port 1 Configuration

Allows you to set the parameters of Serial Port 1.

#### Serial Port [Enabled]

Allows you to enable or disable Serial Port.

Configuration options: [Disabled] [Enabled]



---

The following item appears only when you set **Serial Port** to **[Enabled]**.

---

#### Change Settings [Auto]

Allows you to choose the setting for Super IO device.

Configuration options: [Auto] [IO=3F8h; IRQ=4;]

[IO=3F8h; IRQ=3, 4, 5, 6, 7, 9, 10, 11, 12;]

[IO=2F8h; IRQ=3, 4, 5, 6, 7, 9, 10, 11, 12;]

[IO=3E8h; IRQ=3, 4, 5, 6, 7, 9, 10, 11, 12;]

[IO=2E8h; IRQ=3, 4, 5, 6, 7, 9, 10, 11, 12;]

## 5.4.4 Onboard LAN I350 IO Configuration

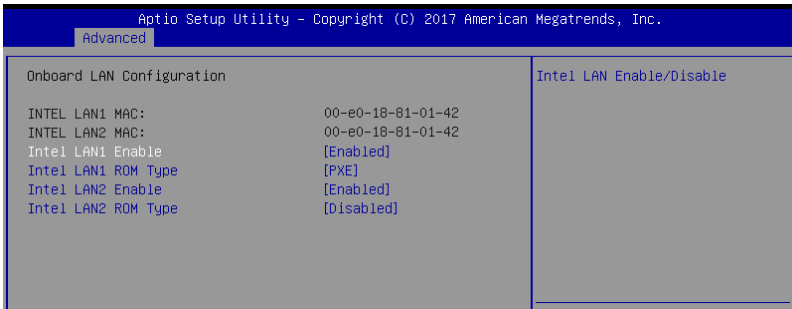

### Intel LAN1 Enable [Enabled]

Allows you to enable or disable the Intel LAN.

Configuration options: [Disabled] [Enabled]



---

The following items appear only when **Intel LAN1 Enable** is set to **[Enabled]**.

---

#### Intel LAN 1 ROM Type [PXE]

Allows you to select the Intel LAN ROM type.

Configuration options: [PXE] [iSCSI] [Disabled]

### Intel LAN2 Enable [Enabled]

Allows you to enable or disable the Intel LAN.

Configuration options: [Disabled] [Enabled]



---

The following items appear only when **Intel LAN2 Enable** is set to **[Enabled]**.

---

#### Intel LAN 2 ROM Type [Disabled]

Allows you to select the Intel LAN ROM type.

Configuration options: [PXE] [iSCSI] [Disabled]

## 5.4.5 Serial Port Console Redirection

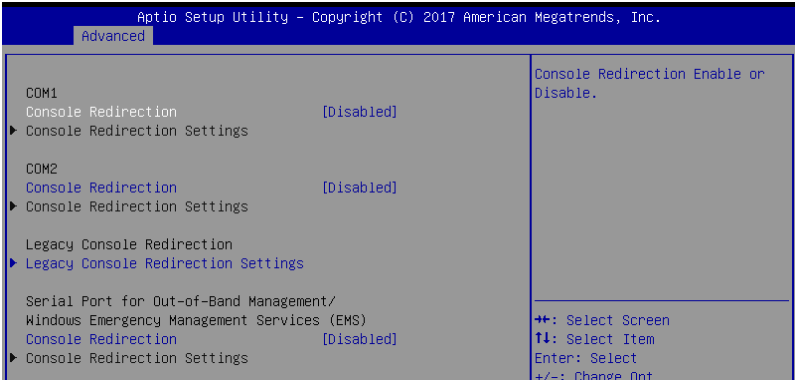

### COM1/COM2

#### Console Redirection [Disabled]

Allows you to enable or disable the console redirection feature.

Configuration options: [Disabled] [Enabled]



---

The following item appears only when you set **Console Redirection** to **[Enabled]**.

---

#### Console Redirection Settings

These items become configurable only when you enable the **Console Redirection** item. The settings specify how the host computer and the remote computer (which the user is using) will exchange data. Both computers should have the same or compatible settings.

##### Terminal Type [VT-UTF8]

Allows you to set the terminal type.

[VT100] ASCII char set.

[VT100+] Extends VT100 to support color, function keys, etc.

[VT-UTF8] Uses UTF8 encoding to map Unicode chars onto 1 or more bytes.

[ANSI] Extended ASCII char set.

##### Bits per second [57600]

Selects serial port transmission speed. The speed must be matched on the other side. Long or noisy lines may require lower speeds.

Configuration options: [9600] [19200] [38400] [57600] [115200]

##### Data Bits [8]

Configuration options: [7] [8]

### **Parity [None]**

A parity bit can be sent with the data bits to detect some transmission errors. [Mark] and [Space] parity do not allow for error detection.

[None]	None
[Even]	parity bit is 0 if the num of 1's in the data bits is even
[Odd]	parity bit is 0 if num of 1's in the data bits is odd
[Mark]	parity bit is always 1
[Space]	parity bit is always 0

### **Stop Bits [1]**

Stop bits indicate the end of a serial data packet. (A start bit indicates the beginning.) The standard setting is 1 stop bit. Communication with slow devices may require more than 1 stop bit.

Configuration options: [1] [2]

### **Flow Control [Hardware RTS/CTS]**

Flow control can prevent data loss from buffer overflow. When sending data, if the receiving buffers are full, a "stop" signal can be sent to stop the data flow. Once the buffers are empty, a "start" signal can be sent to re-start the flow. Hardware flow control uses two wires to send start/stop signals.

Configuration options: [None] [Hardware RTS/CTS]

### **VT -UTF8 Combo Key Support [Enabled]**

This allows you to enable the VT -UTF8 Combination Key Support for ANSI/VT100 terminals.

Configuration options: [Disabled] [Enabled]

### **Recorder Mode [Disabled]**

With this mode enabled only text will be sent. This is to capture Terminal data.

Configuration options: [Disabled] [Enabled]

### **Legacy OS Redirection Resolution [80x24]**

This allows you to set the number of rows and columns supported on the Legacy OS.

Configuration options: [80x24] [80x25]

### **Putty Keypad [VT100]**

This allows you to select the FunctionKey and Keypad on Putty.

Configuration options: [VT100] [LINUX] [XTERMR6] [SCO] [ESCN] [VT400]

### **Redirection After BIOS POST [Always Enable]**

This setting allows you to specify if Bootloader is selected than Legacy console redirection.

Configuration options: [Always Enable] [Bootloader]

## **Legacy Console Redirection Settings**

### **Legacy Console Redirection Port [COM1]**

Allows you to select a COM port to display redirection of Legacy OS and Legacy OPROM Messages.

Configuration options: [COM1] [COM2]

## Serial Port for Out-of-Band Management/Windows Emergency Management Services (EMS)

### Console Redirection [Disabled]

Allows you to enable or disable the console redirection feature.

Configuration options: [Disabled] [Enabled]



---

The following item appears only when you set **Console Redirection** to **[Enabled]**.

---

### Console Redirection Settings

#### Out-of-Band Mgmt Port [COM1]

Microsoft Windows Emergency Management Services (EMS) allow for remote management of a Windows Server OS through a serial port.

Configuration options: [COM1] [COM2]

#### Terminal Type [VT-UTF8]

Microsoft Windows Emergency Management Services (EMS) allow for remote management of a Windows Server OS through a serial port.

Configuration options: [VT100] [VT100+] [VT-UTF8] [ANSI]

#### Bits per second [115200]

Microsoft Windows Emergency Management Services (EMS) allow for remote management of a Windows Server OS through a serial port.

Configuration options: [9600] [19200] [57600] [115200]

#### Flow Control [None]

Microsoft Windows Emergency Management Services (EMS) allow for remote management of a Windows Server OS through a serial port.

Configuration options: [None] [Hardware RTS/CTS] [Software Xon/Xoff]

## 5.4.6 APM

Allows you to configure the Advance Power Management (APM) settings.

Aptio Setup Utility - Copyright (C) 2017 American Megatrends, Inc.		
Advanced		
Restore AC Power Loss	[Last State]	Specify what state to go to when power is re-applied after a power failure (G3 state).
Power On By PCIE	[Disabled]	
Power On By RTC	[Disabled]	

### Restore AC Power Loss [Last State]

When set to [Power Off], the system goes into off state after an AC power loss. When set to [Power On], the system will reboot after an AC power loss. When set to [Last State], the system goes into either off or on state, whatever the system state was before the AC power loss.

Configuration options: [Power Off] [Power On] [Last State]

### Power On By PCIE [Disabled]

[Disabled] Disables the PCIE devices to generate a wake event.

[Enabled] Enables the PCIE devices to generate a wake event.

### Power On By RTC [Disabled]

[Disabled] Disables RTC to generate a wake event.

[Enabled] When set to [Enabled], the items **RTC Alarm Date (Days)** and **Hour/Minute/Second** will become user-configurable with set values.

## 5.4.7 PCI Subsystem Settings

Allows you to configure PCI, PCI-X, and PCI Express Settings.

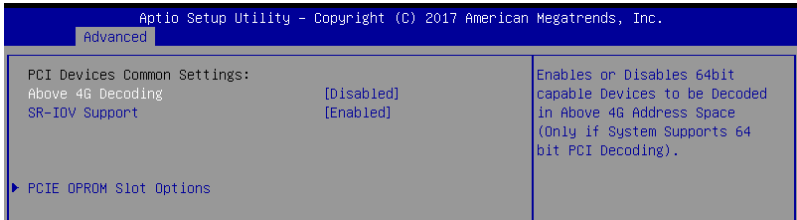

### Above 4G Decoding [Disabled]

Allows you to enable or disable 64-bit capable devices to be decoded in above 4G address space. It only works if the system supports 64-bit PCI decoding.

Configuration options: [Disabled] [Enabled]

### SR-IOV Support [Disabled]

This option enables or disables Single Root IO Virtualization Support if the system has SR-IOV capable PCIe devices.

Configuration options: [Disabled] [Enabled]

### PCIE OPROM Slot Options

#### PCIE1-3 Slot OPROM [Enabled]

This option allows you to enable or disable the OPROM of the PCIe slots.

Configuration options: [Disabled] [Enabled]

#### MEZZ1 Slot OPROM [Enabled]

This option allows you to enable or disable the OPROM of the MEZZ slot.

Configuration options: [Disabled] [Enabled]

## 5.4.8 Network Stack Configuration

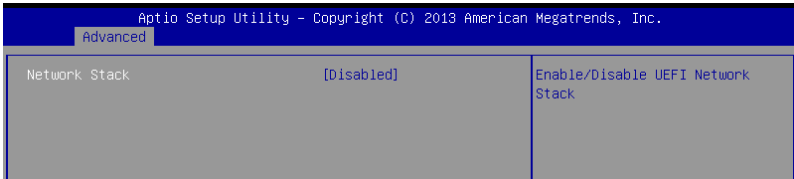

### Network stack [Disabled]

Enables or disables the network stack feature.

Configuration options: [Disable] [Enable]



---

The following item appears only when **Network stack** is set to **[Enabled]**.

---

#### Ipv4 PXE Support [Disabled]

Enables or disables the Ipv4 PXE Boot Support. If disabled, Ipv4 PXE boot option will not be created.

Configuration options: [Disabled] [Enabled]

#### Ipv4 HTTP Support [Disabled]

Enables or disables the Ipv4 HTTP Boot Support. If disabled, Ipv4 HTTP boot option will not be created.

Configuration options: [Disabled] [Enabled]

#### Ipv6 PXE Support [Disabled]

Enables or disables the Ipv6 PXE Boot Support. If disabled, Ipv6 PXE boot option will not be created.

Configuration options: [Disabled] [Enabled]

#### Ipv6 HTTP Support [Disabled]

Enables or disables the Ipv6 HTTP Boot Support. If disabled, Ipv6 HTTP boot option will not be created.

Configuration options: [Disabled] [Enabled]

#### PXE boot wait time [0]

Wait time to press ESC key to abort the PXE boot.

#### Media detect time [1]

Wait time (in seconds) to detect media.

## 5.4.9 CSM Configuration

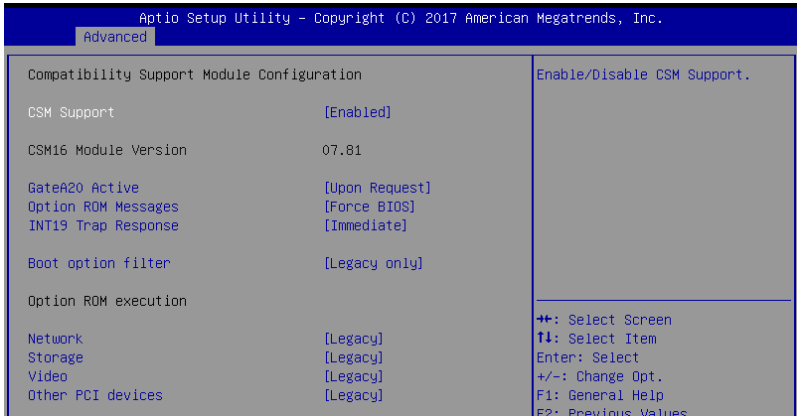

### CSM Support [Enabled]

This option allows you to enable or disable CSM Support.  
Configuration options: [Disabled] [Enabled]



The following item appears only when **CSM Support** is set to **[Enabled]**.

#### GateA20 Active [Upon Request]

This allows you to set the GA20 option.  
Configuration options: [Upon Request] [Always]

#### Option ROM Messages [Force BIOS]

This allows you to set the display mode for option ROM.  
Configuration options: [Force BIOS] [Keep Current]

#### INT19 Trap Response [Immediate]

[Immediate]           Execute the trap right away.  
[Postponed]           Execute the trap during legacy boot.

#### Boot Option filter [Legacy only]

This option allows you to control the Legacy/UEFI ROMs priority.  
Configuration options: [UEFI and Legacy] [Legacy only] [UEFI only]

#### Network / Storage / Video [Legacy]

This option allows you to control the execution of UEFI and Legacy PXE / Storage / Video OpROM.  
Configuration options: [UEFI] [Legacy]

#### Other PCI devices [Legacy]

This item determines the OpROM execution policy for devices other than Network, Storage, or Video.  
Configuration options: [UEFI] [Legacy]

## 5.4.10 NVMe Configuration

This page will display the NVMe controller and drive information.

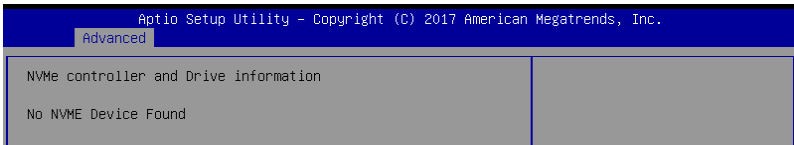

## 5.4.11 USB Configuration

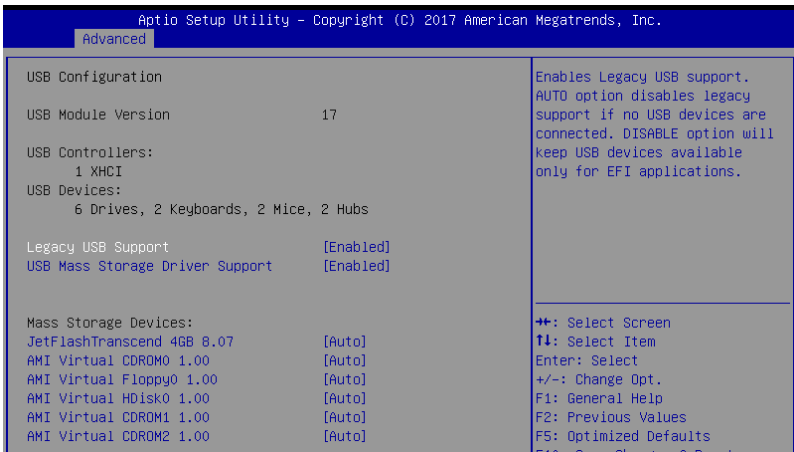

### Legacy USB Support [Enabled]

Allows you to enable or disable Legacy USB device support.

Configuration options: [Enabled] [Disabled] [Auto]

### USB Mass Storage Driver Support [Enabled]

Allows you to enable or disable the USB Mass Storage driver support.

Configuration options: [Disabled] [Enabled]

### Mass Storage Devices

#### AMI Virtual CDROM0-2 / Floppy / HDisk0 1.00 [Auto]

Allows you to select the mass storage device emulation type.

Configuration options: [Auto] [Floppy] [Forced FDD] [Hard Disk] [CD-ROM]

### 5.4.12 iSCSI Configuration

Allows you to configure the iSCSI parameters.

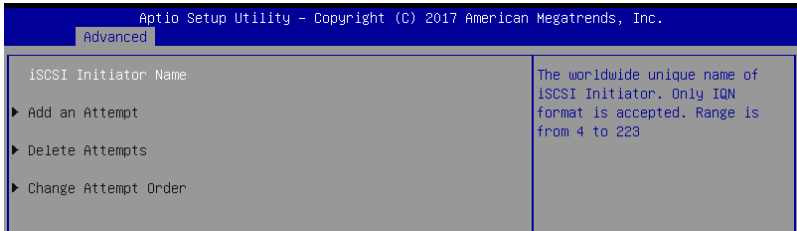

### 5.4.13 Intel(R) RSTe RAID Controller

Allows you to configure the view the RAID volumes and VMD controllers on the system.

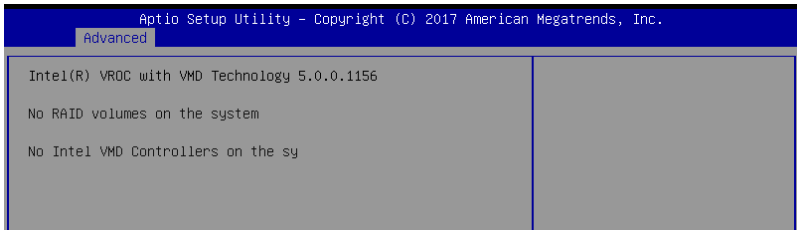

## 5.5 Platform Configuration menu

The IntelRCSetup menu items allow you to change the platform settings.

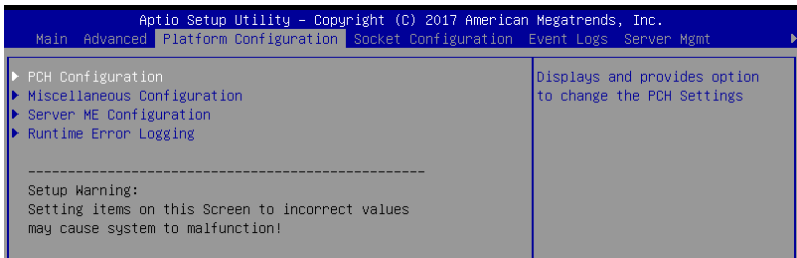

## 5.5.1 PCH Configuration

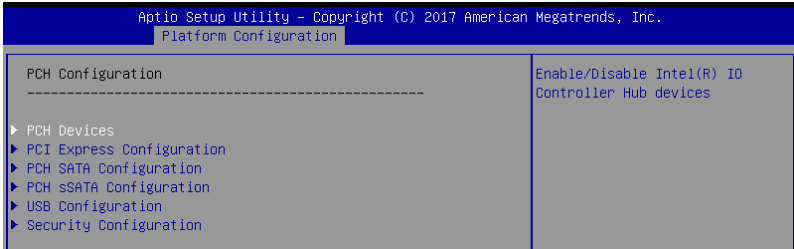

### PCH Devices

#### Board Capability [DeepSx]

[SUS\_PWR\_DN\_ACK] Send.  
[DeepSx] Show DeepSx Policies.

#### DeepSx Power Policies [Disabled]

Allows you to configure the DeepSx Mode configuration.  
Configuration options: [Disabled] [Enabled in S5] [Enabled in S4 and S5]

#### GP27 Wake From DeepSx [Disabled]

Allows you to enable or disable GP27 Wake From DeepSx.  
Configuration options: [Disabled] [Enabled]

### PCI Express Configuration

#### PCI-E ASPM Support (Global) [L1 Only]

Allows you to select ASPM support for all downstream devices.  
Configuration options: [Per individual port] [L1 Only]

#### PCH DMI ASPM [Platform-POR]

Allows you to configure the PCH DMI ASPM.  
Configuration options: [Platform-POR] [ASPM L1] [Disabled]

### PCH SATA Configuration

#### SATA Controller [Enabled]

Allows you to enable or disable the SATA Controller.  
Configuration options: [Disabled] [Enabled]

#### Configure sSATA as [AHCI]

Allows you to identify the SATA port connected to Solid State Drive or Hard Disk Drive.  
Configuration options: [IDE] [AHCI] [RAID]

#### Support Aggressive Link Power Management [Enabled]

Allows you to enable or disable the Support Aggressive Link Power (SALP) Management.  
Configuration options: [Disabled] [Enabled]

## SATA Port 0-7

### Port 0-7

Allows you to enable or disable the SATA port.  
Configuration options: [Disabled] [Enabled]

## PCH sSATA Configuration

### sSATA Controller [Enabled]

Allows you to enable or disable the sSATA Controller.  
Configuration options: [Disabled] [Enabled]

### Configure sSATA as [AHCI]

Allows you to identify the SATA port connected to Solid State Drive or Hard Disk Drive.  
Configuration options: [IDE] [AHCI] [RAID]

### Support Aggressive Link Power Management [Enabled]

Allows you to enable or disable the Support Aggressive Link Power (SALP) Management.  
Configuration options: [Disabled] [Enabled]

### sSATA Port 0-2

#### Port 0-2

Allows you to enable or disable the SATA port.  
Configuration options: [Disabled] [Enabled]

## USB Configuration

### USB Precondition [Disabled]

Allows you to enable or disable precondition work on USB host controller and root ports for faster enumeration.  
Configuration options: [Disabled] [Enabled]

### XHCI Manual Mode [Disabled]

This option is used by validation.  
Configuration options: [Disabled] [Enabled]



---

The following items appears only when the **XHCI Manual Mode** is set to **[Enabled]**.

---

### Trunk Clock Gating (BTCG) [Enabled]

Allows you to enable or disable BTCG.  
Configuration options: [Disabled] [Enabled]

### Enable USB 3.0 pins [Disable all pins]

Allows you to enable or disable USB 3.0 pins or on a per pin basis.  
Configuration options: [Select Per-Pin] [Disable all pins] [Enable all pins]

### USB Per-Connector Disable [Disabled]

Allows you to enable or disable each of the USB physical connectors. Once a connector is disabled, any USB devices plugged into the connector will not be detected by BIOS or OS.  
Configuration options: [Disabled] [Enabled]



The following items appears only when the **USB Per-Connector Disable** is set to **[Enabled]**.

**USB HS Physical Connector #0-13 Disable [Enabled]**

Configuration options: [Disabled] [Enabled]

**USB SS Physical Connector #0-9 Disable [Enabled]**

Configuration options: [Disabled] [Enabled]

## Security Configuration

**SMM BIOS Write Protect [Enabled]**

Allows you to enable or disable SMM BIOS Write Protect.

Configuration options: [Disabled] [Enabled]

## 5.5.2 Miscellaneous Configuration

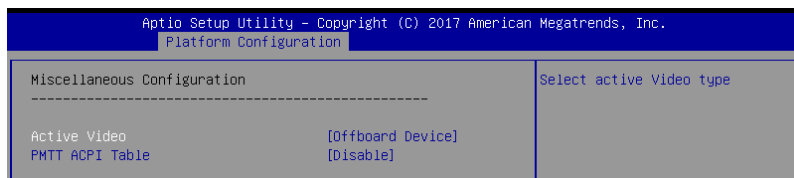

**Active Video [Offboard Device]**

Allows you to select the video type.

Configuration options: [Auto] [Onboard Device] [Offboard Device]

**PMTT ACPI Table [Disabled]**

Allows you to enable or disable PMTT ACPI Table for DDR4 only.

Configuration options: [Disabled] [Enabled]

## 5.5.3 Server ME Configuration

Displays the Server ME Technology parameters on your system.

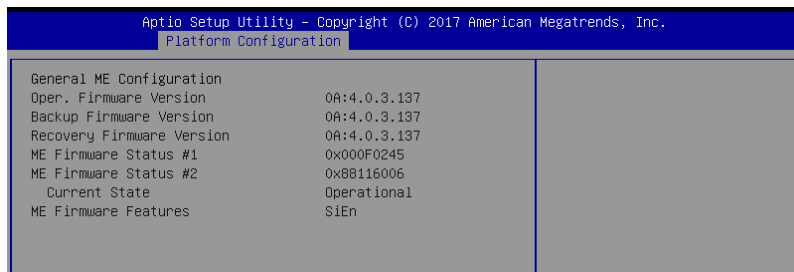

## 5.5.4 Runtime Error Logging Support

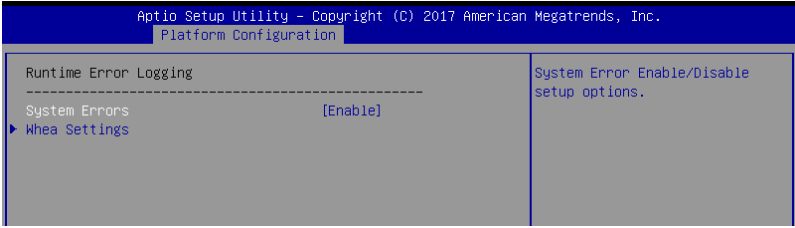

### Runtime Error Logging

#### System Errors [Enabled]

This item allows you to enable or disable System Errors.  
Configuration options: [Disabled] [Enabled]

#### Whea Settings

#### Whea Support [Disabled]

This item allows you to enable or disable the WHEA support.  
Configuration options: [Disabled] [Enabled]

## 5.6 Socket Configuration menu

The IntelRCSetup menu items allow you to change the socket settings.

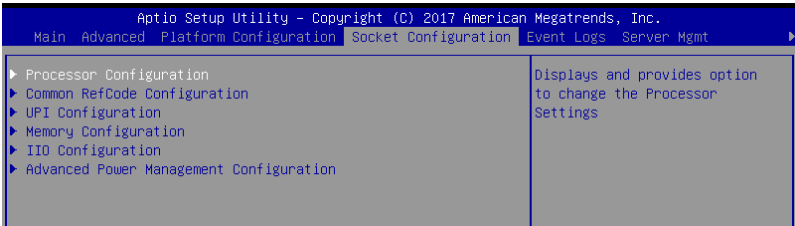

## 5.6.1 Processor Configuration

### Hyper-Threading [Enabled]

Allows you to enable or disable the Hyper-Threading Technology function. When disabled, only one thread per activated core is enabled.

Configuration options: [Disabled] [Enabled]

### Execute Disable Bit [Enabled]

XD can prevent certain classes of malicious buffer overflow attacks when combined with a supporting OS (Windows Server 2003 SP1, Windows XP SP2, SuSE Linux 9.2, Redhat Enterprise 3 Update 3).

Configuration options: [Disabled] [Enabled]

### Enable Intel(R) TXT Support [Disabled]

Forces the XD feature log to always return 0 when disabled.

Configuration options: [Disabled] [Enabled]

### VMX [Enabled]

Enables the Vanderpool Technology. Takes effect after reboot.

Configuration options: [Disabled] [Enabled]

### Enable SMX [Disabled]

Enables the Safer Mode Extensions.

Configuration options: [Disabled] [Enabled]

**Hardware Prefetcher [Enabled]**

This Item allows you to turn on/off the mid level cache(L2) streamer prefetcher.  
Configuration options: [Disabled] [Enabled]

**Adjacent Cache Prefetch [Enabled]**

This Item allows you to turn on/off prefetching of adjacent cache lines.  
Configuration options: [Disabled] [Enabled]

**DCU Streamer Prefetcher [Enabled]**

This Item allows you to enable or disable prefetcher of next L1 data line.  
Configuration options: [Disabled] [Enabled]

**DCU IP Prefetcher [Enabled]**

This Item allows you to enable or disable prefetch of next L1 line based upon sequential load history.  
Configuration options: [Disabled] [Enabled]

**LLC Prefetch [Disabled]**

This Item allows you to enable or disable LLC Prefetch on all threads.  
Configuration options: [Disabled] [Enabled]

**DCU Mode [32K 8Way Without ECC]**

Configuration options: [32K 8Way Without ECC] [16K 4Way With ECC]

**Extended APIC [Disabled]**

This Item allows you to enable or disable the extended APIC support.  
Configuration options: [Disabled] [Enabled]

**AES-NI [Enabled]**

This Item allows you to enable or disable the AES-NI support.  
Configuration options: [Disabled] [Enabled]

**5.6.2 Common RefCode Configuration**

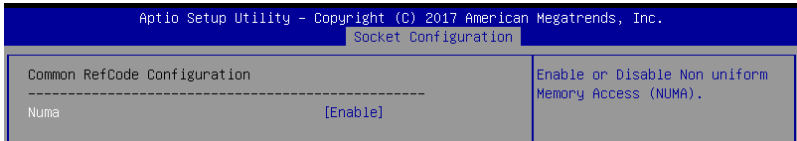

**Numa [Enabled]**

This item enables or disables the Non uniform Memory Access (NUMA).  
Configuration options: [Disabled] [Enabled]

## 5.6.3 UPI Configuration

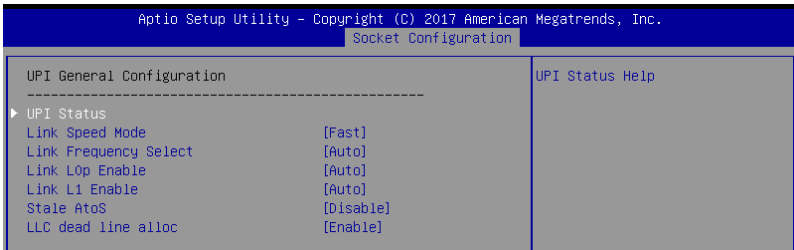

### UPI General Configuration

#### UPI Status

This item displays information about the UPI status.

#### Link Speed Mode [Fast]

This item allows you to select the UPI link speed as either the fast mode or slow mode.

Configuration options: [Slow] [Fast]

#### Link Frequency Select [Auto]

This item allows for selecting the UPI link frequency.

Configuration options: [Auto] [9.6 GB/s] [10.4 GB/s] [Use Per Link Setting]

#### UPI Link0p Enable [Enabled]

Configuration options: [Disabled] [Enabled] [Auto]

#### UPI Link1 Enable [Enabled]

Configuration options: [Disabled] [Enabled] [Auto]

#### Stale AtoS [Disabled]

Configuration options: [Disabled] [Enabled] [Auto]

#### LLC dead line alloc [Enabled]

Configuration options: [Disabled] [Enabled] [Auto]

## 5.6.4 Memory Configuration

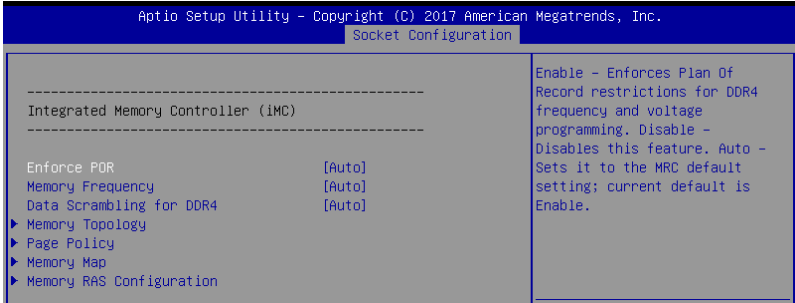

### Enforce POR [Auto]

Allows you to enforce POR restrictions for DDR4 frequency and voltage programming.  
Configuration options: [Auto] [POR] [Disabled]

### Memory Frequency [Auto]

Allows you to select the memory frequency setting.  
Configuration options: [Auto] [1800] - [3000-OvrClk]

### Data Scrambling for DDR4 [Auto]

Allows you to enable or disable data scrambling.  
Configuration options: [Auto] [Disabled] [Enabled]

### Memory Topology

Displays memory topology with DIMM population information.

### Page Policy

Allows you to configure Page Policy settings.

#### Page Policy [Disabled]

Configuration options: [Auto] [Closed] [Adaptive]

### Memory Map

#### IMC Interleaving [Auto]

Select different IMC interleaving setting.  
Configuration options: [Auto] [1-way Interleave] [2-way Interleave]

#### Channel Interleaving [Auto]

Select different channel interleaving setting.  
Configuration options: [Auto] [1-way Interleave] [2-way Interleave]  
[3-way Interleave]

**Rank Interleaving [Auto]**

Select different rank interleaving setting.

Configuration options: [Auto] [1-way Interleave] [2-way Interleave]  
[4-way Interleave] [8-way Interleave]

**Memory RAS Configuration****Mirror Mode [Disabled]**

Allows you to select Mirror Modes. Mirror Mode will set entire 1LM/2LM memory in system to be mirrored, consequently reducing the memory capacity by half. Enabling Mirror Mode will disable XPT Prefetch.

Configuration options: [Disabled] [Mirror Mode 1LM] [Mirror Mode 2LM]

**UEFI ARM Mirror [Disabled]**

Allows you to enable or disable UEFI ARM Mirror.

Configuration options: [Disabled] [Enabled]

**Memory Rank Sparing [Disabled]**

Allows you to enable or disable Memory Rank Sparing

Configuration options: [Disabled] [Enabled]

**Patrol Scrub [Enabled]**

Allows you to enable or disable Patrol Scrub.

Configuration options: [Disabled] [Enabled]

## 5.6.5 I/O Configuration

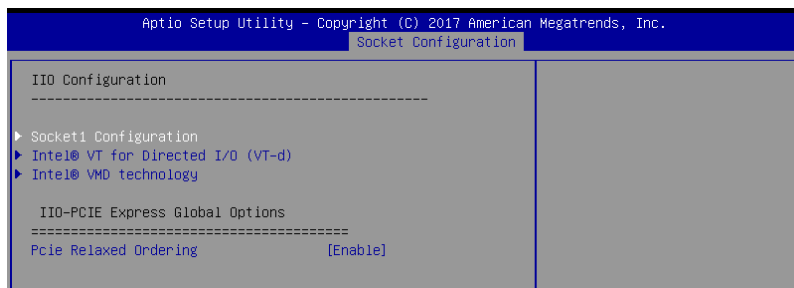

### Socket Configuration

#### **PCIE1 / PCIE2 / MEZZPCIE1 Option ROM [Enabled]**

Allows you to enable or disable the PCIE1 / PCIE2 / MEZZPCIE1 Option ROM.

Configuration options: [Disabled] [Enabled]

### Intel(R) VT for Directed I/O (VT-d)

#### **Intel(R) VT for Directed I/O (VT-d) [Disabled]**

Allows you to enable or disable the Intel Virtualization Technology for Directed I/O.

Configuration options: [Disabled] [Enabled]

### Intel(R) VMD Technology

#### **Intel(R) VMD for Volume Management Device on Socket 0-3**

Allows you to enable or disable the Intel(R) VMD for Volume Management Device Technology on a specific stack.

Configuration options: [Disabled] [Enabled]

### PCI Express Global Options

#### **PCIe relaxed Ordering [Enabled]**

Allows you to enable or disable PCIe relaxed Ordering.

Configuration options: [Disabled] [Enabled]

## 5.6.6 Advanced Power Management Configuration

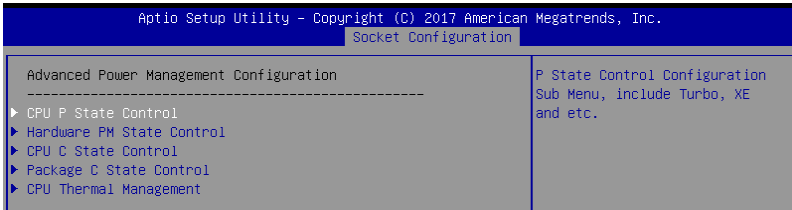

### CPU P State Control

#### Boot performance mode [Max Performance]

Allows you to switch between Boot performance mode.

Configuration options: [Max Performance] [Max Efficient] [Set by Intel Node Manager]

#### Energy Efficient Turbo [Enabled]

Allows you to enable or disable Energy Efficient Turbo.

Configuration options: [Disabled] [Enabled]

#### Turbo Mode [Enabled]

Allows you to enable or disable Turbo Mode.

Configuration options: [Disabled] [Enabled]

### Hardware PM State Control

#### Hardware P-States [Native Mode]

Allows you to switch between Hardware P-States mode.

Configuration options: [Disabled] [Native Mode] [Out of Band Mode] [Native Mode with no Legacy Support]

### CPI C State Control

#### Autonomous Core C-State [Disabled]

Allows you to enable or disable Autonomous Core C-State Report.

Configuration options: [Disabled] [Enabled]

#### CPU C6 Report [Auto]

Allows you to select CPU C6 Report.

Configuration options: [Disabled] [Enabled] [Auto]

#### OS ACPI Cx [ACPI C2]

Allows you to select OS ACPI Cx Report.

Configuration options: [ACPI C2] [ACPI C3]

## Package C State Control

### Package C State [Auto]

Allows you to select Package C State.

Configuration options: [C0/C1 state] [C2 state] [C6(non Retention state)] [C6(Retention state)] [No Limit] [Auto]

## CPU Thermal Control

### CPU T-State Control

#### Software Controlled T-States [Disabled]

Allows you to enable or disable Software Controlled T-States.

Configuration options: [Disabled] [Enabled]

## 5.7 Event Logs menu

The Event Logs menu items allow you to change the event log settings and view the system event logs.

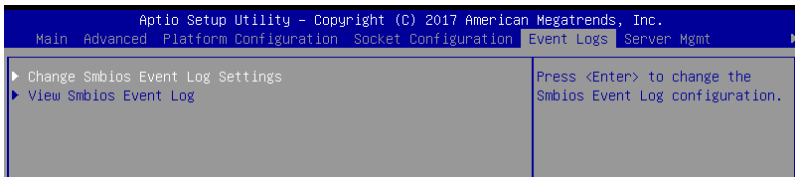

### 5.7.1 Change Smbios Event Log Settings

Press <Enter> to change the Smbios Event Log configuration.



---

All values changed here do not take effect until computer is restarted.

---

### Enabling/Disabling Options

#### Smbios Event Log [Enabled]

Change this to enable or disable all features of Smbios Event Logging during boot.

Configuration options: [Disabled] [Enabled]

#### Erasing Settings

#### Erase Event Log [No]

Choose options for erasing Smbios Event Log. Erasing is done prior to any logging activation during reset.

Configuration options: [No] [Yes, Next reset] [Yes, Every reset]

### 5.7.2 View Smbios Event Log

Press <Enter> to view all smbios event logs.

## 5.8 Server Mgmt menu

The Server Management menu displays the server management status and allows you to change the settings.

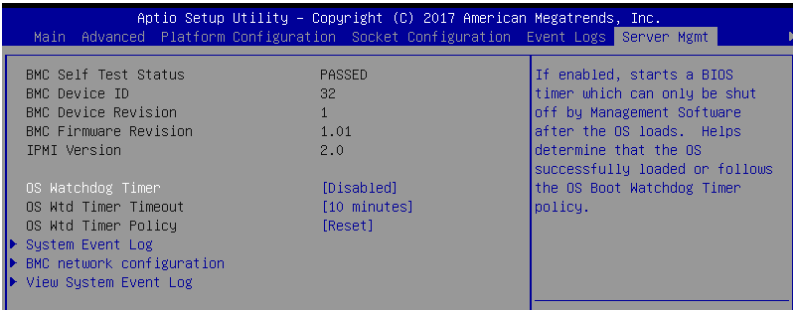

### OS Watchdog Timer [Disabled]

This item allows you to start a BIOS timer which can only be shut off by Intel Management Software after the OS loads.

Configuration options: [Disabled] [Enabled]



---

The following items is configurable only when the **OS Watchdog Timer** is set to **[Enabled]**.

---

#### OS Wtd Timer Timeout [10 minutes]

Allows you to configure the length fo the OS Boot Watchdog Timer.

Configuration options: [5 minutes] [10 minutes] [15 minutes] [20 minutes]

#### OS Wtd Timer Policy [Reset]

This item allows you to configure the how the system should respond if the OS Boot Watch Timer expires.

Configuration options: [Do Nothing] [Reset] [Power Down]

### System Event Log

Allows you to change the SEL event log configuration.

#### Erase SEL [No]

Allows you to choose options for erasing SEL.

Configuration options: [No] [Yes, On next reset] [Yes, On every reset]

#### When SEL is Full [Do Nothing]

Allows you to choose options for reactions to a full SEL.

Configuration options: [Do Nothing] [Erase Immediately]

### BMC network configuration

The sub-items in this configuration allow you to configure the BMC network parameters.

### View System Event Log

This item allows you to view the system event log records.

## 5.9 Security menu

This menu allows a new password to be created or a current password to be changed. The menu also enables or disables the Secure Boot state and lets the user configure the System Mode state.

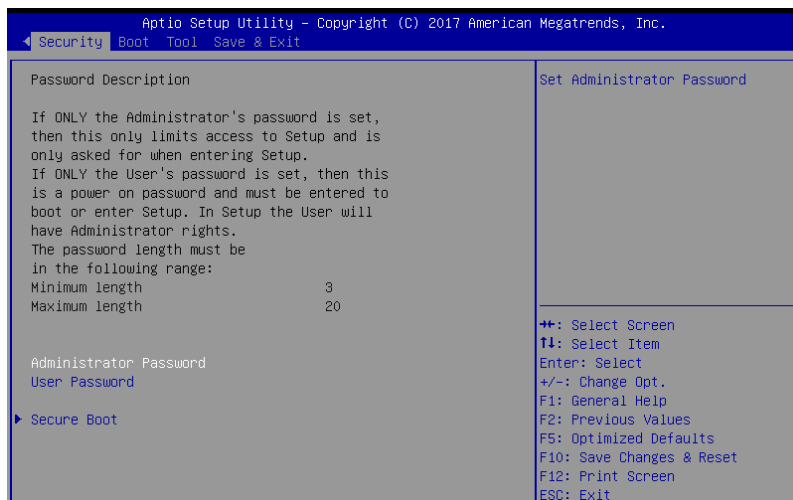

### Administrator Password

To set an administrator password:

1. Select the Administrator Password item and press <Enter>.
2. From the Create New Password box, key in a password, then press <Enter>.
3. Confirm the password when prompted.

To change an administrator password:

1. Select the Administrator Password item and press <Enter>.
2. From the Enter Current Password box, key in the current password, then press <Enter>.
3. From the Create New Password box, key in a new password, then press <Enter>.
4. Confirm the password when prompted.



---

To clear the administrator password, follow the same steps as in changing an administrator password, but press <Enter> when prompted to create/confirm the password.

---

## User Password

To set a user password:

1. Select the User Password item and press <Enter>.
2. From the Create New Password box, key in a password, then press <Enter>.
3. Confirm the password when prompted.

To change a user password:

1. Select the User Password item and press <Enter>.
2. From the Enter Current Password box, key in the current password, then press <Enter>.
3. From the Create New Password box, key in a new password, then press <Enter>.
4. Confirm the password when prompted.

To clear a user password:

1. Select the Clear User Password item and press <Enter>.
2. Select **Yes** from the Warning message window then press <Enter>.

## Secure Boot

This item allows you to customize the Secure Boot settings.

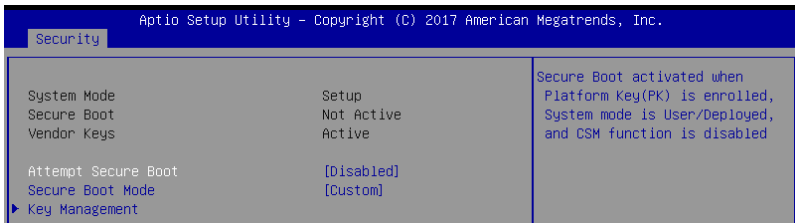

### Attempt Secure Boot [Disabled]

Secure Boot can be enabled if the system is running in User mode with enrolled platform Key (EPK) or if the CSM function is disabled.

Configuration options: [Disabled] [Enabled]

### Secure Boot Mode [Custom]

Allows you to set the Secure Boot selector.

Configuration options: [Custom] [Standard]

## Key Management

This item only appears when the item Secure Boot Mode is set to [Custom]. The Key Management item allows you to modify Secure Boot variables and set Key Management page.

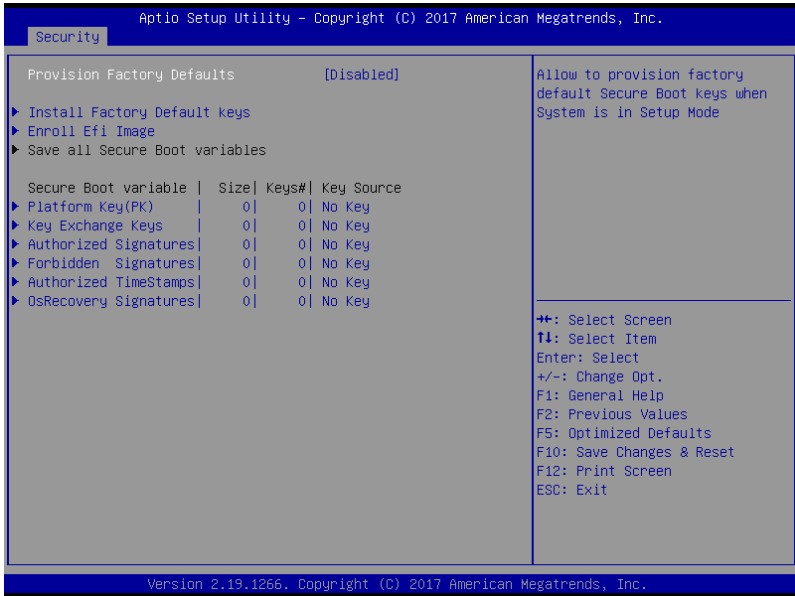

### Provision Factory Defaults [Disabled]

Allows you to provision factory default Secure Boot keys when the system is in Setup Mode.

Configuration options: [Disabled] [Enabled]

### Install Factory Default keys

This item will install all Factory Default keys.

### Enroll Efi Image

This item will allow the image to run in Secure Boot mode.

### Save All Secure Boot Variables

This item will ask you if you want to save all secure boot variables. Select Yes if you want to save all secure boot variables, otherwise select No.

### Platform Key (PK) / Key Exchange Key (KEK) / Authorized Signatures (DB) / Forbidden Signatures (DBX) / Authorized TimeStamps (DBT) / OsRecovery Signatures

Configuration options: [Erase] [Set New] [Save to File]

## 5.10 Boot menu

The Boot menu items allow you to change the system boot options.

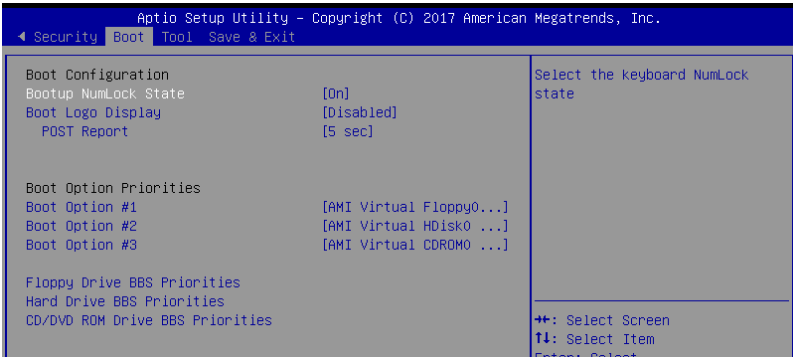

### Bootup NumLock State [On]

Allows you to select the power-on state for the NumLock.

Configuration options: [Off] [On]

### Boot Logo Display [Auto]

Allows you to enable or disable the full screen logo display feature.

Configuration options: [Auto] [Full Screen] [Disabled]

### POST Report [5 sec]

Allows you to set the desired POST Report waiting time from 1 to 10 seconds.

Configuration options: [1 sec] ~ [10 sec] [Until Press ESC]

### Boot Option Priorities

These items specify the boot device priority sequence from the available devices. The number of device items that appears on the screen depends on the number of devices installed in the system.



- To select the boot device during system startup, press <F8> when ASUS Logo appears.
- To access Windows OS in Safe Mode, please press <F8> after POST.

### Floppy Drive BBS Priorities / Hard Drive BBS Priorities / CD/DVD ROM Drive BBS Priorities

These items appear only when you connect Floppy / SATA ODD or HDD to the SATA ports and allow you to set the booting order of the SATA devices.

# 5.11 Tool menu

The Tool menu items allow you to configure options for special functions. Select an item then press <Enter> to display the submenu.

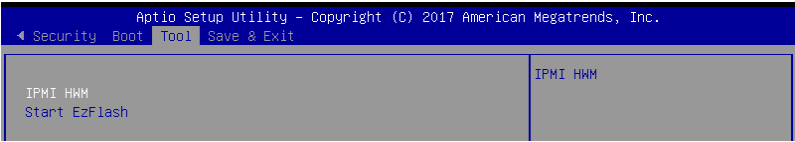

## IPMI HWM

Allows you to run the IPMI hardware monitor.

## Start EZ Flash

Allows you to run ASUS EZ Flash BIOS ROM Utility when you press <Enter>. Refer to the ASUS EZ Flash Utility section for details.

## 5.12 Exit menu

The Exit menu items allow you to save or discard your changes to the BIOS items.

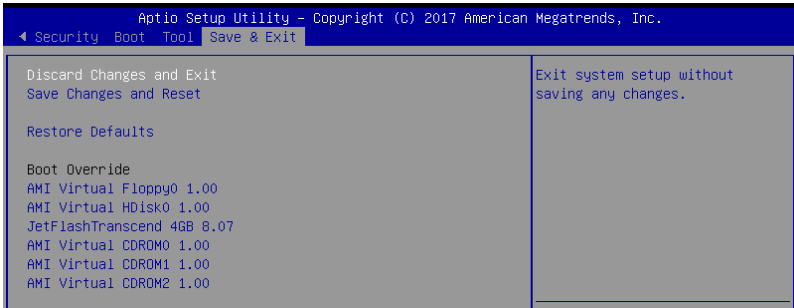

Pressing <Esc> does not immediately exit this menu. Select one of the options from this menu or <F10> from the legend bar to exit.

### Discard Changes & Exit

Exit System setup without saving any changes.

### Save Changes & Reset

Exit System setup after saving the changes.

### Restore Defaults

Restore/load default values for all the setup options.

### Boot Override

These items displays the available devices. The device items that appears on the screen depends on the number of devices installed in the system. Click an item to start booting from the selected device.



# **RAID Configuration**

# 6

This chapter provides instructions for setting up, creating, and configuring RAID sets using the available utilities.

## 6.1 Setting up RAID

The motherboard supports the Intel® Rapid Storage Technology enterprise Option ROM Utility with RAID 0, RAID 1, RAID 10, and RAID 5 support (for Windows OS and Linux).

### 6.1.1 RAID definitions

**RAID 0 (Data striping)** optimizes two identical hard disk drives to read and write data in parallel, interleaved stacks. Two hard disks perform the same work as a single drive but at a sustained data transfer rate, double that of a single disk alone, thus improving data access and storage. Use of two new identical hard disk drives is required for this setup.

**RAID 1 (Data mirroring)** copies and maintains an identical image of data from one drive to a second drive. If one drive fails, the disk array management software directs all applications to the surviving drive as it contains a complete copy of the data in the other drive. This RAID configuration provides data protection and increases fault tolerance to the entire system. Use two new drives or use an existing drive and a new drive for this setup. The new drive must be of the same size or larger than the existing drive.

**RAID 10** is data striping and data mirroring combined without parity (redundancy data) having to be calculated and written. With the RAID 10 configuration you get all the benefits of both RAID 0 and RAID 1 configurations. Use four new hard disk drives or use an existing drive and three new drives for this setup.

**RAID 5** stripes both data and parity information across three or more hard disk drives. Among the advantages of RAID 5 configuration include better HDD performance, fault tolerance, and higher storage capacity. The RAID 5 configuration is best suited for transaction processing, relational database applications, enterprise resource planning, and other business systems. Use a minimum of three identical hard disk drives for this setup.



---

If you want to boot the system from a hard disk drive included in a created RAID set, copy first the RAID driver from the support DVD to a floppy disk before you install an operating system to the selected hard disk drive.

---

## 6.1.2 Installing hard disk drives

The motherboard supports Serial ATA for RAID set configuration. For optimal performance, install identical drives of the same model and capacity when creating a disk array.

To install the SATA hard disks for RAID configuration:

1. Install the SATA hard disks into the drive bays following the instructions in the system user guide.
2. Connect a SATA signal cable to the signal connector at the back of each drive and to the SATA connector on the motherboard.
3. Connect a SATA power cable to the power connector on each drive.

## 6.1.3 Setting the RAID item in BIOS

You must set the RAID item in the BIOS Setup before you can create a RAID set from SATA hard disk drives attached to the SATA connectors supported by Intel® C621 chipset.

To do this:

1. Enter the BIOS Setup during POST.
2. Go to the **Platform Configuration menu** Menu > **PCH Configuration** Menu > **PCH SATA Configuration**, then press <Enter>.
3. Set **Configure sSATA as** to [RAID Mode]
4. Press <F10> to save your changes and exit the BIOS Setup.



---

Refer to Chapter 5 for details on entering and navigating through the BIOS Setup.

---

## 6.1.4 RAID configuration utilities

Depending on the RAID connectors that you use, you can create a RAID set using the utilities embedded in each RAID controller. For example, use the **Intel® Rapid Storage Technology** if you installed Serial ATA hard disk drives on the Serial ATA connectors supported by the Intel® C621 chipset.

Refer to the succeeding section for details on how to use the RAID configuration utility.

## 6.2 Intel® Rapid Storage Technology enterprise SATA/SSATA Option ROM Utility

The Intel® Rapid Storage Technology enterprise SATA/SSATA Option ROM utility allows you to create RAID 0, RAID 1, RAID 10 (RAID 1+0), and RAID 5 set from Serial ATA hard disk drives that are connected to the Serial ATA connectors supported by the Southbridge.



Before you proceed, ensure that you have installed the Serial ATA hard disk drives, have set the correct jumper settings of the motherboard, and have set the correct SATA mode in the BIOS setup. You can refer to the **Installing hard disk drives** and **Setting the RAID mode sections in BIOS** for more information.

To launch the Intel® Rapid Storage Technology enterprise SATA/SSATA Option ROM utility:

1. Turn on the system.
2. During POST, press <Ctrl>+<I> to display the utility main menu.

```
Intel(R) Rapid Storage Technology enterprise - SATA Option ROM - 3.6.0.1023
Copyright(C) 2003-12 Intel Corporation. All Rights Reserved.

[ MAIN MENU ]
1. Create RAID Volume
2. Delete RAID Volume
3. Reset Disks to Non-RAID
4. Exit

[ DISK/VOLUME INFORMATION ]

RAID Volumes:
None defined.

Physical Disks:
ID Drive Model Serial # Size Type/Status (Vol ID)
0 ST3300656SS HWS00000991753TR 279.3GB Non-RAID Disk
1 ST3300656SS 37VN00009846RAJ1 279.3GB Non-RAID Disk
2 ST3300656SS 397600009846UEDY 279.3GB Non-RAID Disk
3 ST3300656SS GWC50000991756G6 279.3GB Non-RAID Disk

[↑↓]-Select [ESC]-Exit [ENTER]-Select Menu
```

The navigation keys at the bottom of the screen allow you to move through the menus and select the menu options.



The RAID BIOS setup screens shown in this section are for reference only and may not exactly match the items on your screen.

## 6.2.1 Creating a RAID set

To create a RAID set:

1. From the utility main menu, select **1. Create RAID Volume** and press <Enter>.
2. Key in a name for the RAID set and press <Enter>.

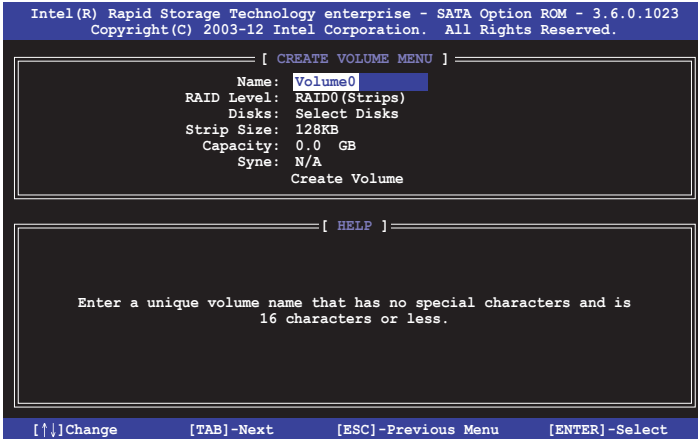

3. Press the up/down arrow keys to select a RAID Level that you wish to create then press <Enter>.
4. From the **Disks** item field, press <Enter> to select the hard disk drives that you want to include in the RAID set.

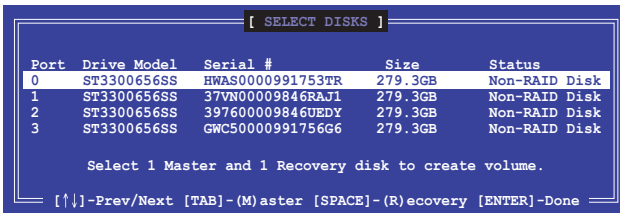

5. Use the up/down arrow keys to move the selection bar then press <Space> to select a disk. A small triangle before the Port number marks the selected drive. Press <Enter> when you are done.

- Use the up/down arrow keys to select the stripe size for the RAID array (for RAID 0, 10 and 5 only) then press <Enter>. The available stripe size values range from 4 KB to 128 KB. The following are typical values:  
RAID 0: 128KB  
RAID 10: 64KB  
RAID 5: 64KB



---

We recommend a lower stripe size for server systems, and a higher stripe size for multimedia computer systems used mainly for audio and video editing.

---

- In the **Capacity** field item, key in the RAID volume capacity that you want to use and press <Enter>. The default value field indicates the maximum allowed capacity.
- Press <Enter> to start creating the RAID volume.
- From the following warning message, press <Y> to create the RAID volume and return to the main menu, or press <N> to go back to the **CREATE VOLUME** menu.



## 6.2.2 Deleting a RAID set



Take caution when deleting a RAID set. You will lose all data on the hard disk drives when you delete a RAID set.

To delete a RAID set:

1. From the utility main menu, select **2. Delete RAID Volume** and press <Enter>.
2. From the Delete Volume Menu, press the up/down arrow keys to select the RAID set you want to delete then press <Del>.

```
Intel(R) Rapid Storage Technology enterprise - SATA Option ROM - 3.6.0.1023
Copyright(C) 2003-12 Intel Corporation. All Rights Reserved.

[ DELETE VOLUME MENU ]

Name      Level      Drives    Capacity  Status    Bootable
Volume0   RAID0 (Stripe)  2         298.0GB   Normal    Yes

[ HELP ]

Deleting a volume will reset the disks to non-RAID

WARNING: ALL DISK DATA WILL BE DELETED.
(This does not apply to Recovery volumes)

[↑↓]-Select      [ESC]-Previous Menu      [DEL]-Delete Volume
```

3. Press <Y> to confirm deletion of the selected RAID set and return to the utility main menu, or press <N> to return to the **DELETE VOLUME** menu.

```
[ DELETE VOLUME VERIFICATION ]

ALL DATA IN THE VOLUME WILL BE LOST!
(This does not apply to Recovery volumes)

Are you sure you want to delete volume "Volume0"? (Y/N):
```

## 6.2.3 Resetting disks to Non-RAID



Take caution before you reset a RAID volume hard disk drive to non-RAID. Resetting a RAID volume hard disk drive deletes all internal RAID structure on the drive.

To reset a RAID set:

1. From the utility main menu, select **3. Reset Disks to Non-RAID** and press <Enter>.
2. Press the up/down arrow keys to select the drive(s) or disks of the RAID set you want to reset, then press <Space>. A small triangle before the Port number marks the selected drive. Press <Enter> when you are done.

```
[ RESET RAID DATA ]
Resetting RAID disk will remove its RAID structures
and revert it to a non-RAID disk.

WARNING: Resetting a disk causes all data on the disk to be lost.
(This does not apply to Recovery volumes)

Port  Drive Model  Serial #          Size      Status
---  -
0     ST3300656SS    HWAS0000991753TR 279.3GB  Member Disk
1     ST3300656SS    37VN00009846RAJ1 279.3GB  Member Disk

Select the disks that should be reset.

[↑↓]-Previous/Next [SPACE]-Selects [ENTER]-Selection Complete
```

3. Press <Y> in the confirmation window to reset the drive(s) or press <N> to return to the utility main menu.

## 6.2.4 Exiting the Intel® Rapid Storage Technology enterprise SATA/SSATA Option ROM utility

To exit the utility:

1. From the utility main menu, select **4. Exit** then press <Enter>.
2. Press <Y> to exit or press <N> to return to the utility main menu.

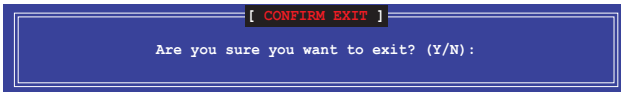

## 6.2.5 Rebuilding the RAID



---

This option is only for the RAID 1 set.

---

### Rebuilding the RAID with other non-RAID disk

If any of the SATA hard disk drives included in the RAID 1 array failed, the system displays the status of the RAID volume as **“Degraded”** during POST. You can rebuild the RAID array with other installed non-RAID disks.

To rebuild the RAID with other non-RAID disk:

1. During POST, press <Ctrl>+<I> at the prompt to enter the Intel Rapid Storage Technology option ROM utility.
2. If there is a non-RAID SATA Hard Disk available, the utility will prompt you to rebuild the RAID. Press the up/down arrow keys to select the destination disk then press <Enter> to start the rebuilding process, or press <ESC> to exit.

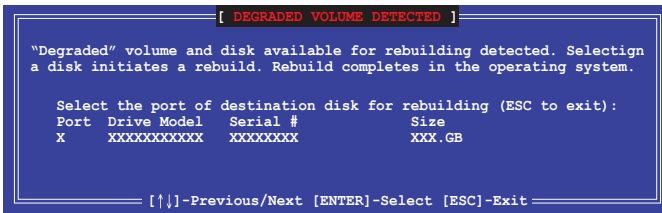

---

Select a destination disk with the same size as the original hard disk.

---

- The utility immediately starts rebuilding after the disk is selected. When done, the status of the degraded RAID volume is changed to **“Rebuild”**.

```

Intel(R) Rapid Storage Technology enterprise - SATA Option ROM - 3.6.0.1023
Copyright(C) 2003-12 Intel Corporation. All Rights Reserved.

===== [ MAIN MENU ] =====
1. Create RAID Volume          3. Reset Disks to Non-RAID
2. Delete RAID Volume         4. Exit

===== [ DISK/VOLUME INFORMATION ] =====

RAID Volumes:
ID  Name      Levell      Strip      Size      *=Data is Encrypted
1   Volume0   RAID1(Mirror)  N/A       149.0GB   Status  Bootable
                                     Rebuild Yes

Physical Devices:
Port  Drive Model  Serial #      Size      Type/Status (Vol ID)
1     ST3160812AS  9LS0F4HL     149.0GB   Member Disk(0)
2     ST3160812AS  3LS0JYL8     149.0GB   Member Disk(0)

Volumes with "Rebuild" status will be rebuilt within the operating system.

[↑↓]-Select      [ESC]-Exit      [ENTER]-Select Menu

```

- Press <Esc> to exit Intel Rapid Storage Technology and reboot the system.
- Select **Start > Programs > Intel Rapid Storage > Intel Rapid Storage Console** or click the **Intel Rapid Storage Technology** tray icon to load the Intel Rapid Storage Manager utility.
- From the **View** menu, select **Advanced Mode** to display the details of the Intel Rapid Storage Console.
- From the **Volumes view** option, select **RAID volume** to view the rebuilding status. When finished, the status is changed to **“Normal”**.

### Rebuilding the RAID with a new hard disk

If any of the SATA hard disk drives included in the RAID array failed, the system displays the status of the RAID volume as **“Degraded”** during POST. You may replace the disk drive and rebuild the RAID array.

To rebuild the RAID with a new hard disk:

- Remove the failed SATA hard disk and install a new SATA hard disk of the same specification into the same SATA Port.



---

Select a destination disk with the same size as the original hard disk.

---

- Reboot the system then follow the steps in section **Rebuilding the RAID with other non-RAID disk**.

## 6.2.6 Setting the Boot array in the BIOS Setup Utility

You can set the boot priority sequence in the BIOS for your RAID arrays when creating multi-RAID using the Intel® Rapid Storage Technology enterprise SATA Option ROM utility.

To set the boot array in the BIOS:



---

Set at least one of the arrays bootable to boot from the hard disk.

---

1. Reboot the system and press <Del> to enter the BIOS setup utility during POST.
2. Go to the **Boot** menu and select the boot option priority.
3. Use up/down arrow keys to select the boot priority and press <Enter>. See the **Boot menu** section of Chapter 5 for more details.
4. From the **Exit** menu, select **Save Changes & Exit**, then press <Enter>.
5. When the confirmation window appears, select **Yes**, then press <Enter>.

## 6.3 Intel® Rapid Storage Technology enterprise (Windows)

The Intel® Rapid Storage Technology enterprise allows you to create RAID 0, RAID 1, RAID 10 (RAID 1+0), and RAID 5 set(s) from Serial ATA hard disk drives that are connected to the Serial ATA connectors supported by the Southbridge.



You need to manually install the Intel® Rapid Storage Technology enterprise utility on a Windows® operating system. Please refer to the installation instructions in Chapter 7.

To enter the Intel® Rapid Storage Technology enterprise utility under Windows operating system:

1. Turn on the system and go to the windows desktop.
2. Click the **Intel® Rapid Storage Technology enterprise** icon to display the main menu.

Your storage system is configured for data protection, increased performance and optimal data storage capacity. You can create additional volumes to further optimize your storage system.

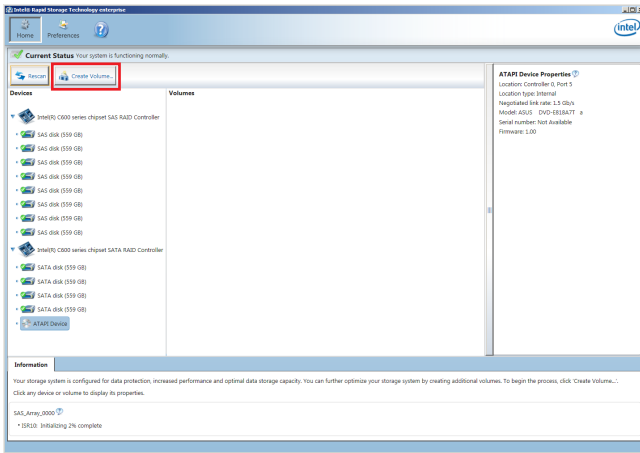

You can click **Rescan** to re-scan any attached hard disks.

## 6.3.1 Creating a RAID set

To create a RAID set:

1. From the utility main menu, select **Create Volume** and select volume type.
2. Click **Next**.

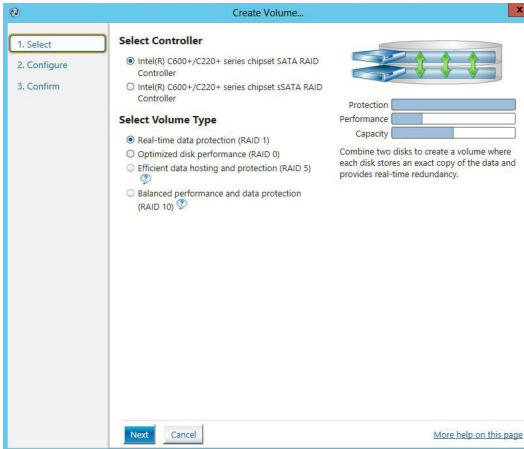

3. Enter a name for the RAID set, then select the array disks.
4. Select **Volume Size** tab, you can drag the bar to decide the volume size.
5. Click **Next**.

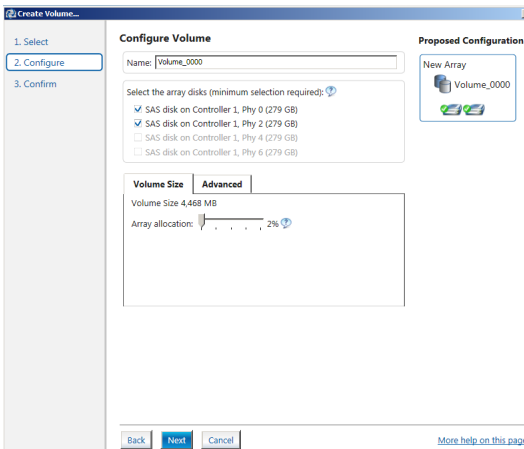

- If you do not want to keep the data on one of the selected disks, select **NO** when prompted.
- If you want to **Enable volume write-back cache** or **Initialize volume**, click **Advanced**.

6. Confirm the volume creation, then click **Create Volume** to continue.



This process could take a while depending on the number and size of the disks. You can continue using other applications during this time.

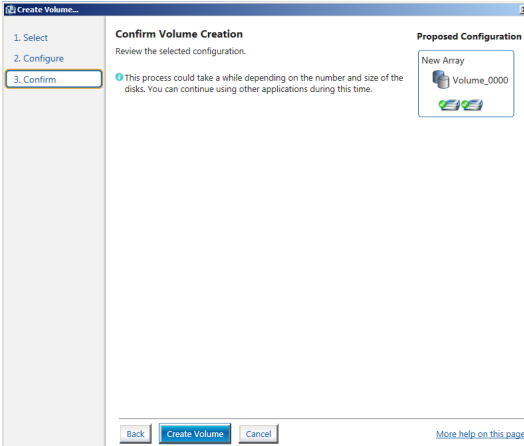

7. Wait until the process is completed, then click **OK** when prompted.

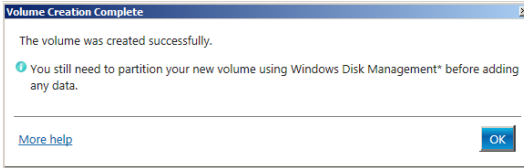

You still need to partition your new volume using Windows Disk Management before adding any data.

The RAID set is displayed in the **Volumes** list and you can change the settings in **Volume Properties**.

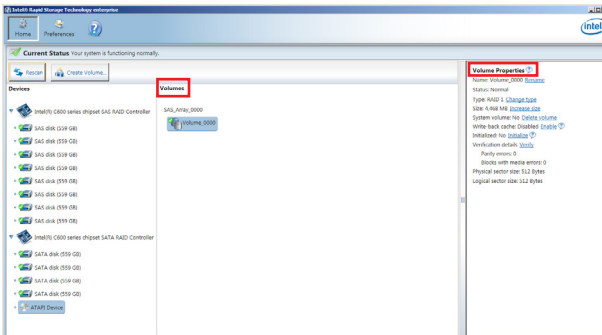

## 6.3.2 Changing a Volume Type

To change the volume type in **Volume Properties**:

1. Click the SATA array items you want to change in **Volumes** field.
2. From the **Volume Properties** field, select **Type: RAID 1 Change type**.

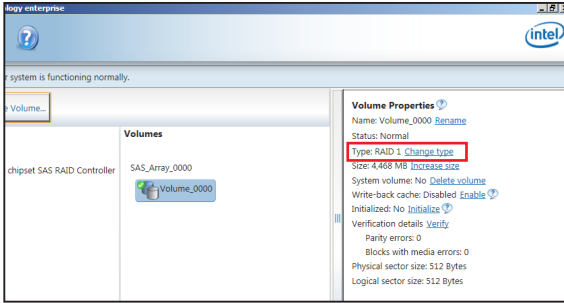

3. You can change the **Name**, **Select the new volume type**, and **Select additional disks to include in the new volume** if needed.
4. Select the **Data stripe size** for the RAID array (for RAID 0, 10 and 5 only), and click **OK**. The available stripe size values range from 4 KB to 128 KB. The following are typical values:  
RAID 0: 128KB  
RAID 10: 64KB  
RAID 5: 64KB

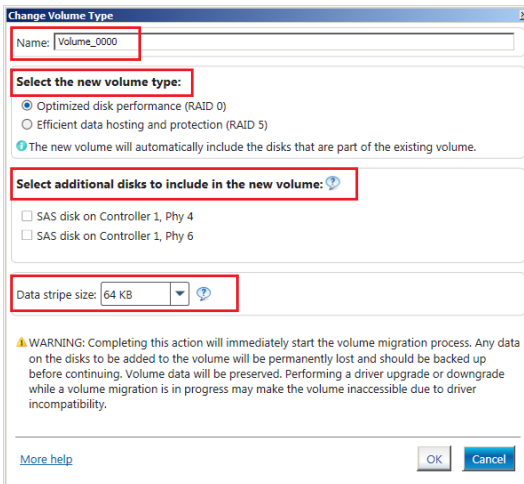

We recommend a lower stripe size for server systems, and a higher stripe size for multimedia computer systems used mainly for audio and video editing.

### 6.3.3 Deleting a volume



Be cautious when deleting a volume. You will lose all data on the hard disk drives. Before you proceed, ensure that you back up all your important data from your hard drives.

To delete a volume:

1. From the utility main menu, select the volume (ex. Volume\_0000) in **Volumes** field you want to delete.

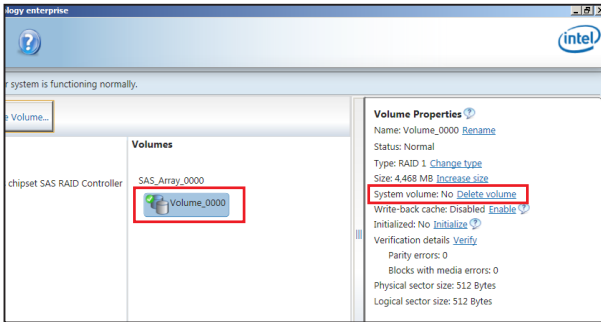

2. Select **Delete volume** in **Volume Properties** field. The following screen appears.

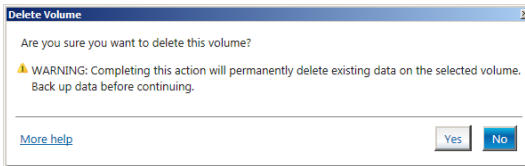

3. Click **Yes** to delete the volume and return to the utility main menu, or click **No** to return to the main menu.

## 6.3.4 Preferences

### System Preferences

Allow you to set to show the notification area icon and show system information, warning, or errors here.

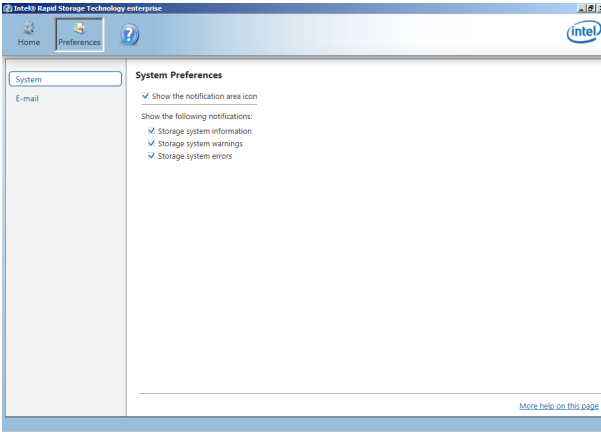

### E-Mail Preferences

Allow you to set to sent e-mail of the following events:

- Storage system information
- Storage system warnings
- Storage system errors

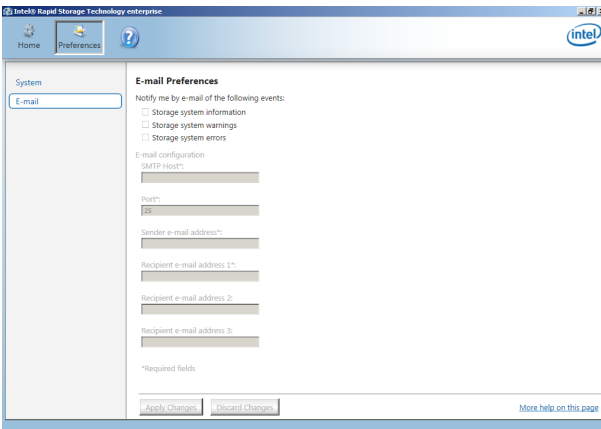

# 6.4 Intel® Virtual Raid on CPU in BIOS

This feature allows you to do CPU RAID functions with Intel® CPU RSTe.



- Due to chipset behavior, enabling the Intel® RSTe CPU RAID functions requires an Intel® VROC hardware key module.
- Refer to section **4.4 Internal connectors** for the location of the VROC\_KEY1 connector.
- The KEY module is purchased separately.

To enter the Intel® Virtual Raid on CPU in BIOS:

1. Enter the BIOS Setup during POST.
2. Go to the **Advanced** menu > **CSM Configuration**, then press <Enter> to display the CSM Configuration menu.



Refer to Chapter 5 for details on entering and navigating through the BIOS Setup.

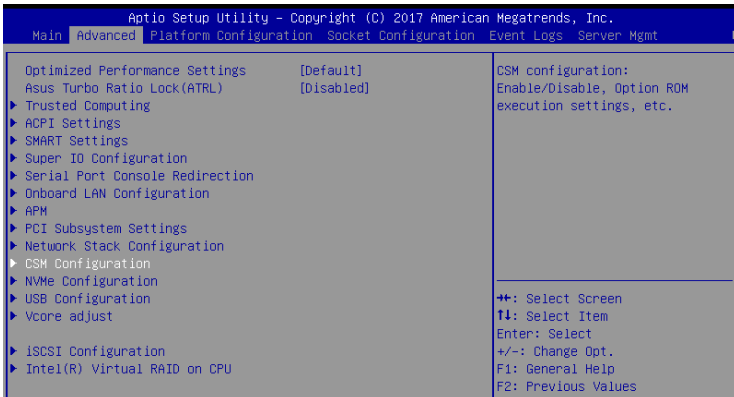

3. Select the **[Disabled]** option for the CSM Support option in the CSM Configuration menu.



- Go to the **Save & Exit** menu > **Save Changes and Reset**, or press <F10> to save and reset.
- Enter the BIOS Setup again during POST.
- Go to the **Advanced** menu > **Intel(R) Virtual Raid on CPU** > **All Intel VMD Controllers** then press <Enter> to display the Intel® Virtual Raid on CPU menu.

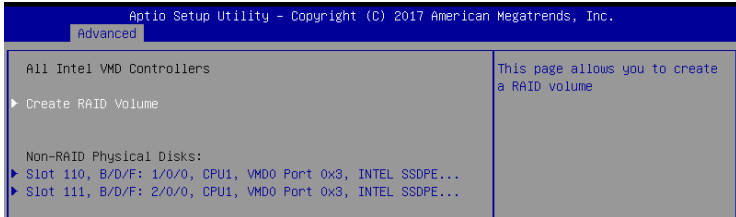

## 6.4.1 Creating a RAID set

To create a RAID set:

- From the Intel® Virtual Raid on CPU menu, select **Create RAID Volume** and press <Enter>. The following screen appears:

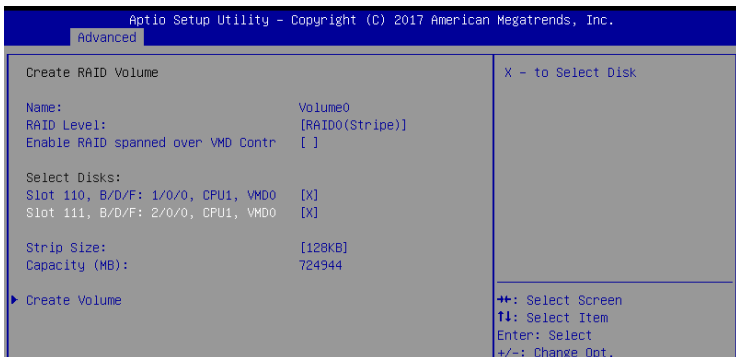

- When the **Name** item is selected, enter a name for the RAID set and press <Enter>.
- When the **RAID Level** item is selected, press <Enter> to select the RAID level to create, and then press <Enter>.
- When the **Enable RAID spanned over VMD Controllers** item is selected, press <Enter> and select **X** to enable this function.
- Under **Select Disks**, press <Enter> and select **X** for the disks you want to include in the RAID set.

6. When the **Strip Size** item is selected, press <Enter> to select strip size for the RAID array (for RAID 0, 10 and 5 only), and then press <Enter>. The available strip size values range from 4 KB to 128 KB. The following are typical values:
  - RAID 0: 128 KB
  - RAID 10: 64 KB
  - RAID 5: 64 KB



---

We recommend a lower strip size for server systems, and a higher strip size for multimedia computer systems used mainly for audio and video editing.

---

7. When the **Capacity (MB)** item is selected, enter the RAID volume capacity that you want and press <Enter>. The default value indicates the maximum allowed capacity.
8. When the **Create Volume** item is selected, press <Enter> to create the RAID volume and return to the Intel® Rapid Storage Technology menu.

## 6.4.2 Deleting a RAID set





---

Be cautious when deleting a RAID set. You will lose all data on the hard disk drives when you delete a RAID set.

---

To delete a RAID set:

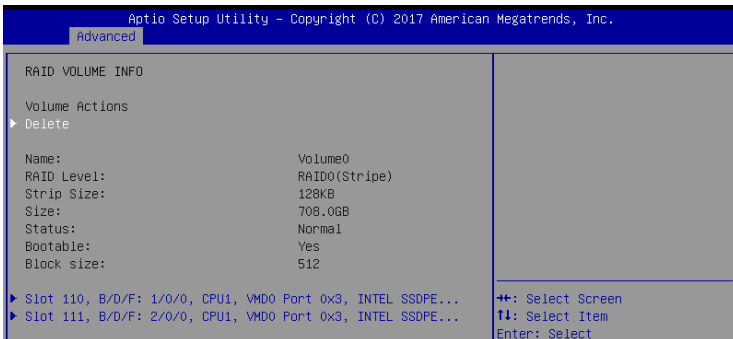
1. From the Intel® Virtual Raid on CPU menu, select the RAID volume you want to delete and press <Enter>. The following screen appears:



2. When the **Delete** item is selected, press <Enter>, then select **Yes** to delete the RAID volume and return to the Intel® Virtual Raid on CPU menu, or select **No** to cancel.



# Driver Installation

# 7

This chapter provides the instructions for installing the necessary drivers for different system components in the Windows® Operating Systems.

## 7.1 RAID driver installation

After creating the RAID sets for your server system, you are now ready to install an operating system to the independent hard disk drive or bootable array. This part provides the instructions on how to install the RAID controller drivers during OS installation.

### 7.1.1 Creating a USB flash drive with RAID drive

When installing Windows® Server OS, you can load the RAID driver from a USB flash drive. You can create a USB flash drive with RAID driver in Windows by copying the files from the support DVD to the USB flash drive.

To copy the RAID driver to a USB flash drive in Windows environment:

1. Place the motherboard support DVD in the optical drive.
2. Connect a USB flash drive to your system.
3. Click on the optical drive to browse the contents of the support DVD.
4. Click **Drivers > C620 INTEL RAID > Windows > Driver** and then copy the RAID driver folder to the USB flash drive.

### 7.1.2 Installing the RAID controller driver

#### During Windows® Server 2012 R2 OS installation

To install the RAID controller driver when installing Windows® Server 2012 R2 OS:

1. Boot the computer using the Windows® Server 2012 R2 OS installation disc. Follow the screen instructions to start installing Windows Server 2012 R2.
2. When prompted to choose a type of installation, click **Custom: Install Windows only (advanced)**.

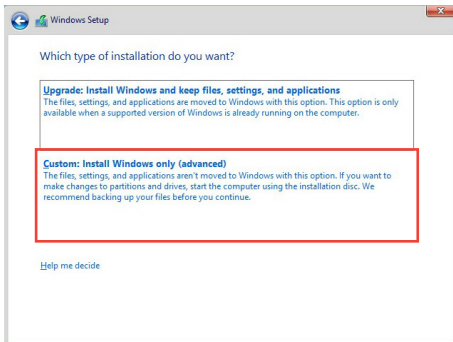

3. Click **Load Driver**.

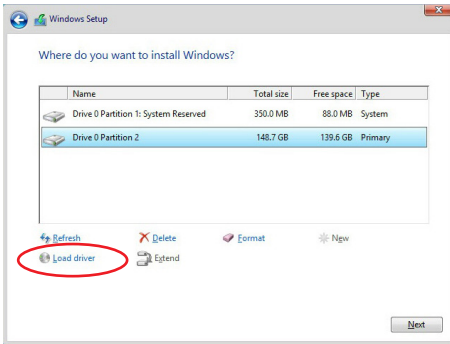

4. A message appears reminding you to insert the installation media containing the driver of the RAID controller driver (the installation media can be a CD, DVD, or USB flash drive).
- If you have only one optical drive installed in your system, eject the Windows OS installation disc and replace with the motherboard Support DVD into the optical drive.
  - Or you may connect a USB flash drive containing the RAID controller driver.

Click **Browse** to continue.

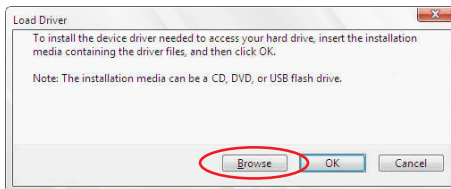

5. Locate the driver in the corresponding folder of the Support DVD or USB flash drive and then click **OK** to continue.
6. Select the RAID controller driver you need from the list and click **Next**.

7. When the system finishes loading the RAID driver,
  - Replace the motherboard Support DVD with the Windows Server installation disc.
  - Remove the USB flash drive.

Select the drive to install Windows and click **Next**.

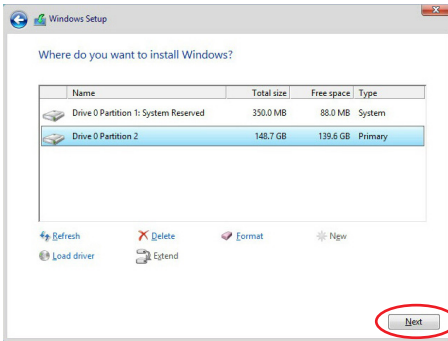

8. Setup then proceeds with the OS installation. Follow screen instructions to continue.

## 7.2 Management applications and utilities installation

The support DVD that is bundled with your motherboard contains drivers, management applications, and utilities that you can install to maximize the features of your motherboard.



1. The contents of the support DVD are subject to change at any time without notice. Visit the ASUS website ([www.asus.com](http://www.asus.com)) for the latest updates on software and utilities.
2. The support DVD is supported on Windows® Server 2012 R2 and Windows® Server 2016.

## 7.3 Running the Support DVD

When you place the support DVD into the optical drive, the DVD automatically displays the main screen if Autorun is enabled in your computer. By default, the Drivers tab is displayed.



If Autorun is NOT enabled in your computer, browse the contents of the support DVD to locate the file **ASSETUP.EXE** from the **BIN** folder. Double-click the **ASSETUP.EXE** to run the support DVD.

The main screen of the Support DVD contains the following tabs:

1. Drivers
2. Utilities
3. Manual
4. Contact



The main screen of the Support DVD looks exactly the same on the Windows® Server 2012 R2 and on the Windows® Server 2016 Operating System (OS).

### 7.3.1 Drivers menu tab

The Drivers Menu shows the available device drivers if the system detects installed devices. Install the necessary drivers to activate the devices.

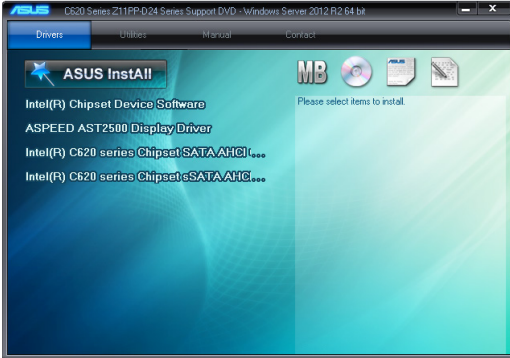

### 7.3.2 Utilities menu tab

The Utilities menu displays the software applications and utilities that the motherboard supports.



### 7.3.3 Manual menu

The Manual menu provides the link to the Broadcom NetXtreme II Network Adapter user guide.



You need an internet browser installed in your OS to view the User Guide.



### 7.3.4 Contact information menu

The Contact menu displays the ASUS contact information, e-mail addresses, and useful links if you need more information or technical support for your motherboard.

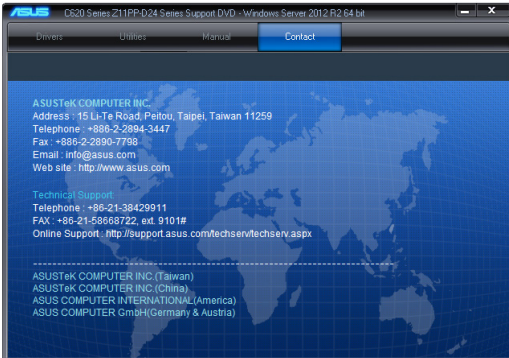

# 7.4 Intel® chipset device software installation

This section provides the instructions on how to install the Intel® chipset device software on the system.

You need to manually install the Intel® chipset device software on a Windows operating system.

To install the Intel® chipset device software:

1. Restart the computer, and then log on with **Administrator** privileges.
2. Insert the motherboard/system support DVD into the optical drive. The support DVD automatically displays the **Drivers** menu if Autorun is enabled in your computer.



If Autorun is NOT enabled in your computer, browse the contents of the support DVD to locate the file **ASSETUP.EXE** from the **BIN** folder. Double-click the **ASSETUP.EXE** to run the support DVD.

3. Click the item **Intel® Chipset Device Software** from the menu.

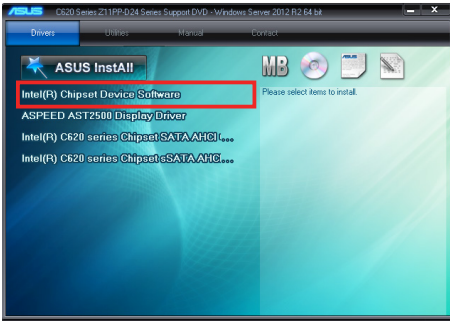

4. The **Intel® Chipset Device Software** window appears. Click **Next** to start the installation.

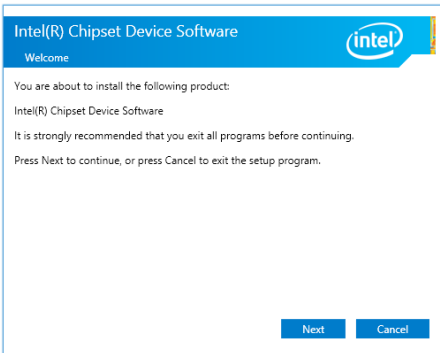

5. Read the **License Agreement** and click **Accept** to continue the process.

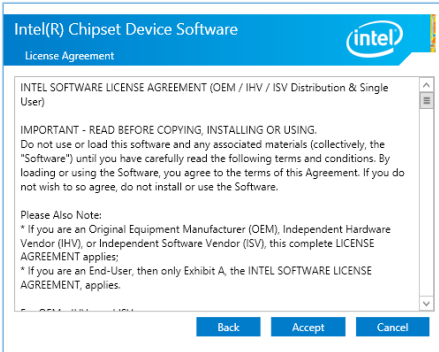

6. Read the **Readme File Information** and click **Install** to start the installation process.

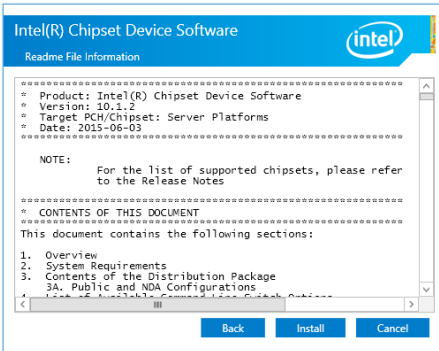

7. Click **Restart Now** to complete the setup process.

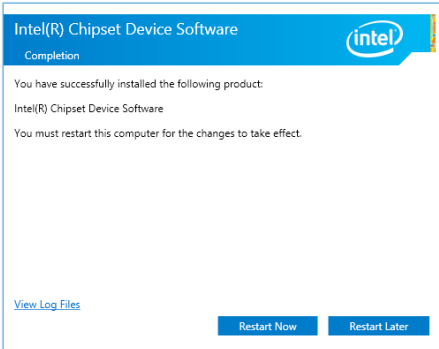

# 7.5 VGA driver installation

This section provides the instructions on how to install the ASPEED Video Graphics Adapter (VGA) driver.

You need to manually install the ASPEED VGA driver on a Windows® operating system.

To install the ASPEED VGA driver:

1. Restart the computer, and then log on with **Administrator** privileges.
2. Insert the motherboard/system support DVD into the optical drive. The support DVD automatically displays the **Drivers** menu if Autorun is enabled in your computer.



If Autorun is NOT enabled in your computer, browse the contents of the support DVD to locate the file **ASSETUP.EXE** from the **BIN** folder. Double-click the **ASSETUP.EXE** to run the support DVD.

3. Click the **ASPEED AST2500 Display Driver** to begin installation.

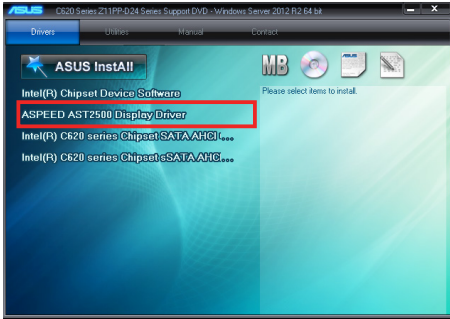

4. From the installation window, click **Next** to start the installation.



5. Click **Install** to start the installation process.

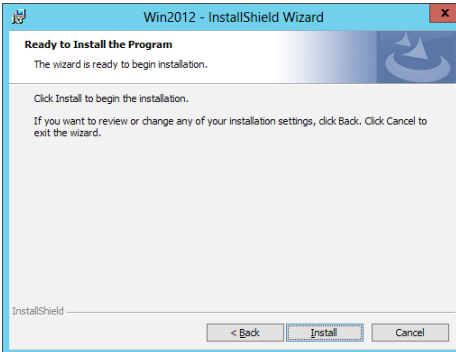

6. Click **Finish** to complete the installation.

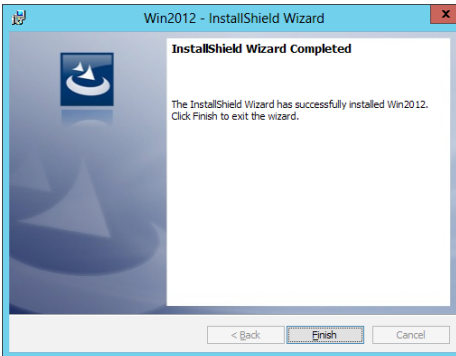

# 7.6 Intel® Rapid Storage Technology enterprise 5.0 installation

This section provides the instructions on how to install the Intel® Rapid Storage Technology enterprise 5.0 on the system.

You need to manually install the Intel® Rapid Storage Technology enterprise 5.0 utility on a Windows® operating system.

To install the Intel® Rapid Storage Technology enterprise 5.0 utility:

1. Restart the computer, and then log on with **Administrator** privileges.
2. Insert the motherboard/system support DVD into the optical drive, and navigate to the **Utilities** menu.
3. Click the **Intel® Rapid Storage Technology enterprise 5.0** to begin installation.



4. The **Intel® Rapid Storage Technology enterprise** window appears. Click **Next** to start the installation.

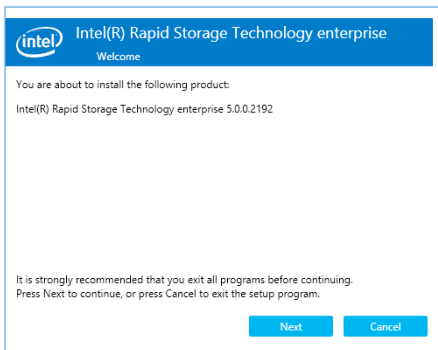

5. Read the **Warning** message and click **Next** to continue.

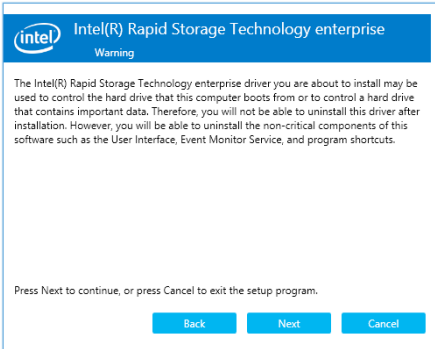

6. Read the **License Agreement** and click **Accept** to continue the process.

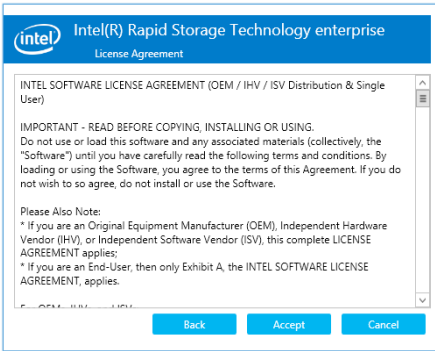

7. Select the destination folder and click **Next** to continue.

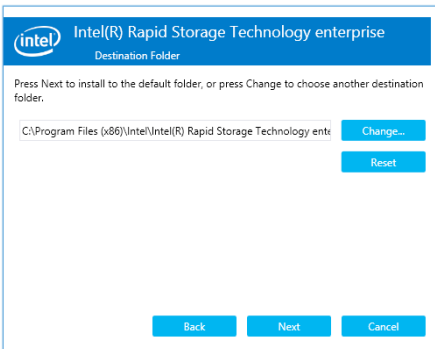

8. Tick the features that you would like to install and click **Next** to continue.

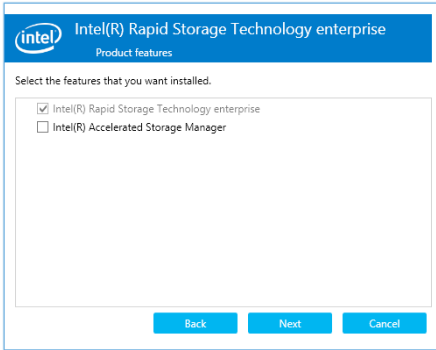

9. Click **Install** to start the installation process.

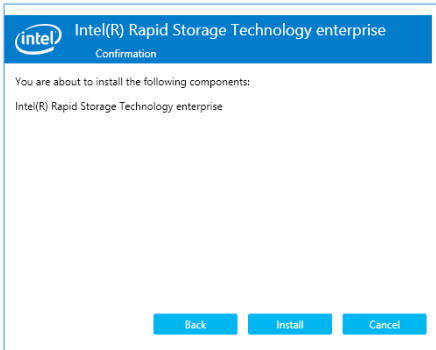

10. Click **Restart Now** to complete the setup process.

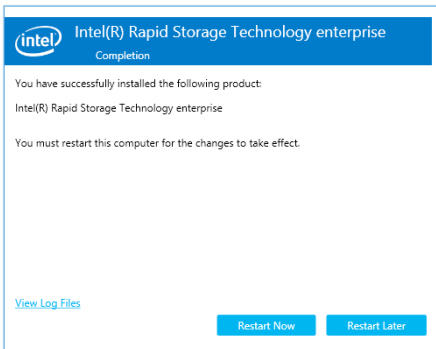

# Appendix

This appendix includes additional information that you may refer to when configuring the motherboard.

# Z11PP-D24 block diagram

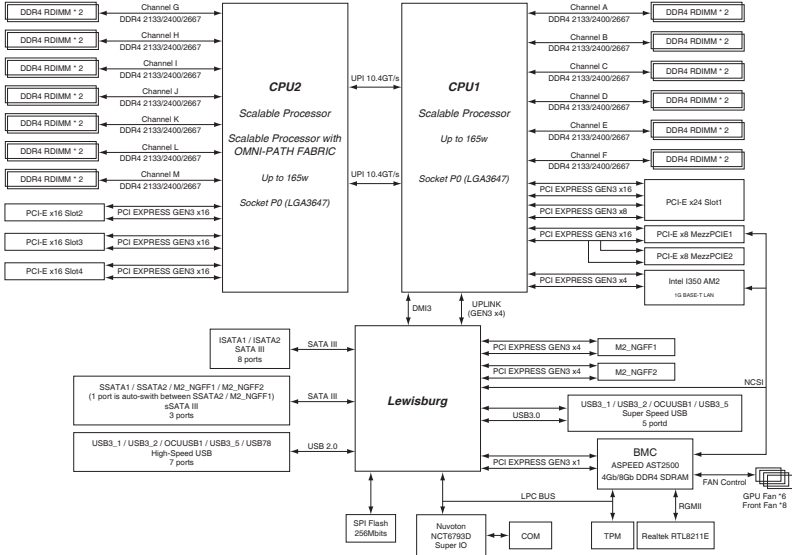

## Notices

### Federal Communications Commission Statement

This device complies with Part 15 of the FCC Rules. Operation is subject to the following two conditions:

- This device may not cause harmful interference.
- This device must accept any interference received including interference that may cause undesired operation.

This equipment has been tested and found to comply with the limits for a Class B digital device, pursuant to Part 15 of the FCC Rules. These limits are designed to provide reasonable protection against harmful interference in a residential installation. This equipment generates, uses and can radiate radio frequency energy and, if not installed and used in accordance with manufacturer's instructions, may cause harmful interference to radio communications. However, there is no guarantee that interference will not occur in a particular installation. If this equipment does cause harmful interference to radio or television reception, which can be determined by turning the equipment off and on, the user is encouraged to try to correct the interference by one or more of the following measures:

- Reorient or relocate the receiving antenna.
- Increase the separation between the equipment and receiver.
- Connect the equipment to an outlet on a circuit different from that to which the receiver is connected.
- Consult the dealer or an experienced radio/TV technician for help.



---

The use of shielded cables for connection of the monitor to the graphics card is required to assure compliance with FCC regulations. Changes or modifications to this unit not expressly approved by the party responsible for compliance could void the user's authority to operate this equipment.

---

### Compliance Statement of Innovation, Science and Economic Development Canada (ISED)

This device complies with Innovation, Science and Economic Development Canada licence exempt RSS standard(s). Operation is subject to the following two conditions: (1) this device may not cause interference, and (2) this device must accept any interference, including interference that may cause undesired operation of the device.

CAN ICES-3(B)/NMB-3(B)

### Déclaration de conformité de Innovation, Sciences et Développement économique Canada (ISED)

Le présent appareil est conforme aux CNR d'Innovation, Sciences et Développement économique Canada applicables aux appareils radio exempts de licence. L'exploitation est autorisée aux deux conditions suivantes : (1) l'appareil ne doit pas produire de brouillage, et (2) l'utilisateur de l'appareil doit accepter tout brouillage radioélectrique subi, même si le brouillage est susceptible d'en compromettre le fonctionnement.

CAN ICES-3(B)/NMB-3(B)

## REACH

Complying with the REACH (Registration, Evaluation, Authorization, and Restriction of Chemicals) regulatory framework, we published the chemical substances in our products at ASUS website at <http://csr.asus.com/english/REACH.htm>.

## ASUS Recycling/Takeback Services

ASUS recycling and takeback programs come from our commitment to the highest standards for protecting our environment. We believe in providing solutions for you to be able to responsibly recycle our products, batteries, other components as well as the packaging materials. Please go to <http://csr.asus.com/english/Takeback.htm> for detailed recycling information in different regions.



---

**DO NOT** throw the motherboard in municipal waste. This product has been designed to enable proper reuse of parts and recycling. This symbol of the crossed out wheeled bin indicates that the product (electrical and electronic equipment) should not be placed in municipal waste. Check local regulations for disposal of electronic products.

---



---

**DO NOT** throw the mercury-containing button cell battery in municipal waste. This symbol of the crossed out wheeled bin indicates that the battery should not be placed in municipal waste.

---

## Australia statement notice

From 1 January 2012 updated warranties apply to all ASUS products, consistent with the Australian Consumer Law. For the latest product warranty details please visit <https://www.asus.com/support/>. Our goods come with guarantees that cannot be excluded under the Australian Consumer Law. You are entitled to a replacement or refund for a major failure and compensation for any other reasonably foreseeable loss or damage. You are also entitled to have the goods repaired or replaced if the goods fail to be of acceptable quality and the failure does not amount to a major failure.

If you require assistance please call ASUS Customer Service 1300 2787 88 or visit us at <https://www.asus.com/support/>.

## ASUS contact information

### ASUSTeK COMPUTER INC.

Address 4F, No. 150, Li-Te Rd., Peitou, Taipei 112, Taiwan  
Telephone +886-2-2894-3447  
Fax +886-2-2890-7798  
Web site <https://www.asus.com>

#### **Technical Support**

Telephone +86-21-38429911  
Fax +86-21-58668722 ext: 9101  
Online Support <https://www.asus.com/support/Product/ContactUs/Services/questionform/?lang=en>

### ASUSTeK COMPUTER INC. (Taiwan)

Address 4F, No. 150, Li-Te Rd., Peitou, Taipei 112, Taiwan  
Telephone +886-2-2894-3447  
Fax +886-2-2890-7798  
Web site <https://www.asus.com/tw/>

#### **Technical Support**

Telephone +886-2-2894-3447 (0800-093-456)  
Online Support <https://www.asus.com/support/Product/ContactUs/Services/questionform/?lang=zh-tw>

### ASUSTeK COMPUTER INC. (China)

Address No. 5077, Jindu Road, Minhang District, Shanghai, China  
Telephone +86-21-5442-1616  
Fax +86-21-5442-0099  
Web site <https://www.asus.com.cn>

#### **Technical Support**

Telephone +86-20-2804-7506 (400-620-6655)  
Online Support <https://www.asus.com/support/Product/ContactUs/Services/questionform/?lang=zh-cn>

## ASUS contact information

### ASUS COMPUTER INTERNATIONAL (America)

Address 48720 Kato Rd., Fremont, CA 94538, USA  
Fax +1-510-608-4555  
Web site <https://www.asus.com/us/>

#### **Technical Support**

Support fax +1-812-284-0883  
General support +1-812-282-2787  
Online support <https://www.asus.com/support/Product/ContactUs/Services/questionform/?lang=en-us>

### ASUS COMPUTER GmbH (Germany and Austria)

Address Harkort Str. 21-23, 40880 Ratingen, Germany  
Fax +49-2102-959911  
Web site <https://www.asus.com/de/>

#### **Technical Support**

Telephone +49-1805-010923  
Support Fax +49-2102-959911  
Online support <https://www.asus.com/support/Product/ContactUs/Services/questionform/?lang=de-de>

### ASUS Czech Service s.r.o. (Europe)

Address Na Rovince 887, 720 00 Ostrava – Hrabová,  
Czech Republic  
Telephone +420-596766888  
Web site <https://www.asus.com/cz/>

#### **Technical Support**

Telephone +420-596-766-891  
Fax +420-596-766-329  
E-mail [advance.rma.eu@asus.com](mailto:advance.rma.eu@asus.com)  
Online Support <https://www.asus.com/support/Product/ContactUs/Services/questionform/?lang=cs-cz>

## ASUS contact information

### ASUS Holland BV (The Netherlands)

Address Marconistraat 2, 7825GD EMMEN, The Netherlands  
Web site <https://www.asus.com/nl/>

#### **Technical Support**

Telephone +31-(0)591-5-70292  
Fax +31-(0)591-666853  
E-mail [advance.rma.eu@asus.com](mailto:advance.rma.eu@asus.com)  
Online Support <https://www.asus.com/support/Product/ContactUs/Services/questionform/?lang=nl-nl>

### ASUS Polska Sp. z o.o. (Poland)

Address Ul. Postępu 6, 02-676 Warszawa, Poland  
Web site <https://www.asus.com/pl/>

#### **Technical Support**

Telephone +48-225718033  
Online Support <https://www.asus.com/support/Product/ContactUs/Services/questionform/?lang=pl-pl>

### ASK-Service (Russia and CIS)

Address г.Москва, ул. Орджоникидзе, д.10, Россия  
Telephone (495) 640-32-75  
Web site <https://www.asus.com/ru/>

#### **Technical Support**

Telephone 008-800-100-ASUS (008-800-100-2787)  
Online Support <https://www.asus.com/support/Product/ContactUs/Services/questionform/?lang=ru-ru>

