

INSTALLATION INSTRUCTIONS

PACREM Bluetooth® Remote and Dongle Installation and Instructions

WARNING: In order to prevent any negative effects on the environment and on people, the battery included in this product should be disposed of separately from other household waste, by taking it to authorized collection centers, in accordance with the EU countries local waste disposal legislations.

WARNING: The battery included in this product is compliant with Chapter IV of the Batteries and Waste Batteries Regulation (EU) 2023/1542.

Unpack carton and verify contents. If any listed parts are missing, immediately contact a Chief Customer Service representative.

PARTS

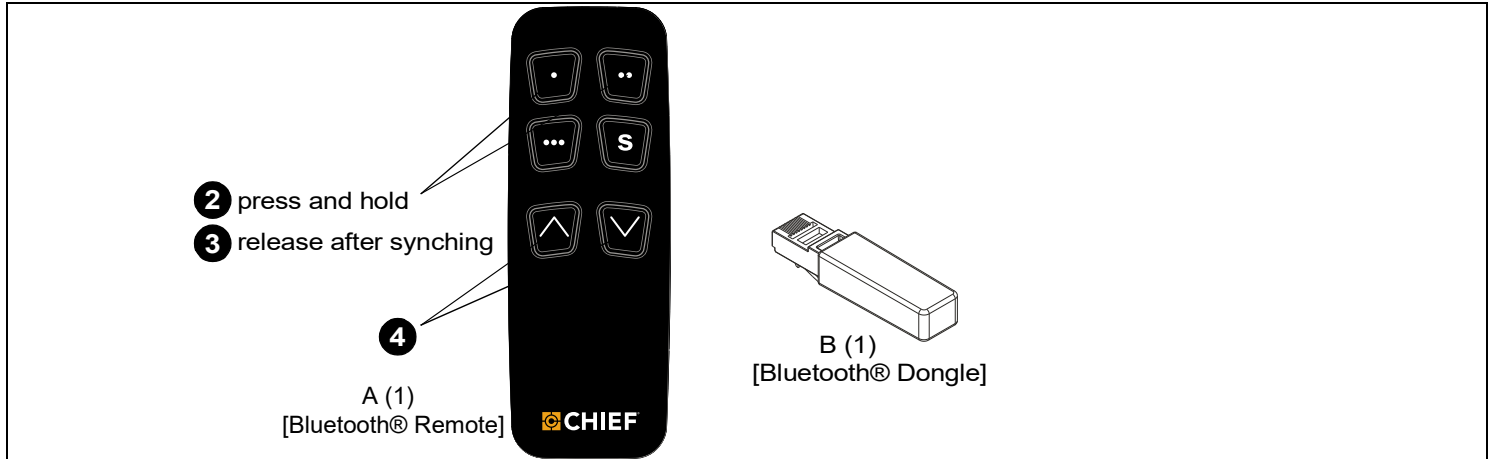

Figure 1

Dongle Installation

1. Plug in the Bluetooth® dongle (B) into the available RJ45 port on the motor control box. (See Figure 2)

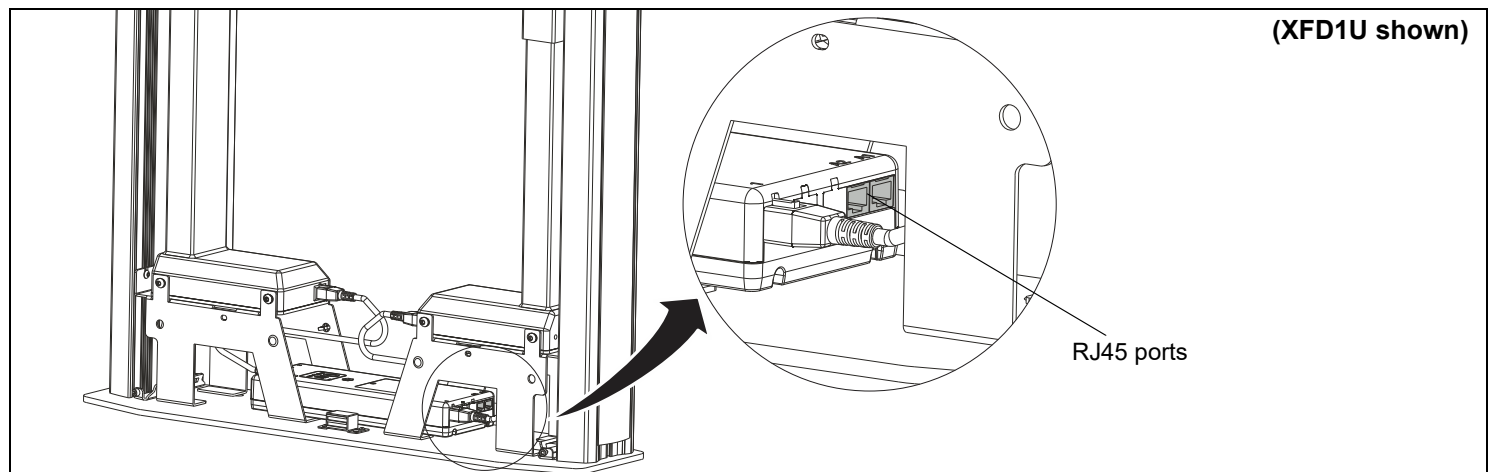

Figure 2

NOTE: Dongle will have a blue "blink" when properly connected.

Continued . . .

Legrand | AV, and its affiliated corporations and subsidiaries (collectively, "Legrand | AV"), intend to make this manual accurate and complete. However, Legrand | AV makes no claim that the information contained herein covers all details, conditions or variations, nor does it provide for every possible contingency in connection with the installation or use of this product. The information contained in this document is subject to change without notice or obligation of any kind. Legrand | AV makes no representation of warranty, expressed or implied, regarding the information contained herein. Legrand | AV assumes no responsibility for accuracy, completeness or sufficiency of the information contained in this document.

CHIEF®

A brand of **legrand**

Chief, a products division of Legrand
10900 Red Circle Drive, Minnetonka, MN 55343

• P: 800.582.6480 / 952.225.6000 • F: 877.894.6918 / 952.894.6918

8800-003064 Rev02

©2026 Legrand | AV

www.legrandav.com

03/2026

INSTALLATION INSTRUCTIONS

Continued. . .

Remote Installation

2. Press and hold top two buttons on the Bluetooth® remote (A). (See Figure 1)

NOTE: The blinking "blue" light on the dongle (B) will stay solid while holding the remote buttons.

3. When the "blue" light on the dongle (B) turns off, the remote is synched and buttons can be released.
4. Test remote functionality by using the up and down buttons. (See Figure 1)

NOTE: The Bluetooth® remote does not require batteries to be installed. The battery pre-installed in the remote will last up to 10 years.

Height Adjustment

5. Press "UP" or "DOWN" buttons to raise or lower height as desired.

Save Height Levels

6. Adjust height until desired preset level is reached using "UP" and "DOWN" buttons.
7. Press "SAVE" button ("S")
8. Press one of three preset buttons (., .. or ...) to save preset position.
9. Repeat Steps 6-8 as desired.

Troubleshooting

If lifting function does not work properly, try to following troubleshooting steps. If none of these work, contact customer service.

1. If there is uneven movement, initialize the control box (reset)
 - Hold "Down" button until lift has reached it's lower limit.
 - Briefly release "Down" button
 - Press and hold "Down" for three seconds, wait until all movement has stopped, then release
2. If there is no movement, check the following
 - Check all cable connectors between controllers and actuators.
 - Check power cable connection to control box.
3. If there is slight movement and then reverse travel, check for any obstructions that may be interfering such as cables or peripheral devices.
4. Contact customer service if none of the above steps fix the problem.

Legrand | AV, and its affiliated corporations and subsidiaries (collectively, "Legrand | AV"), intend to make this manual accurate and complete. However, Legrand | AV makes no claim that the information contained herein covers all details, conditions or variations, nor does it provide for every possible contingency in connection with the installation or use of this product. The information contained in this document is subject to change without notice or obligation of any kind. Legrand | AV makes no representation of warranty, expressed or implied, regarding the information contained herein. Legrand | AV assumes no responsibility for accuracy, completeness or sufficiency of the information contained in this document.

CHIEF®

A brand of  Legrand

Chief, a products division of Legrand
10900 Red Circle Drive, Minnetonka, MN 55343

• P: 800.582.6480 / 952.225.6000 • F: 877.894.6918 / 952.894.6918

8800-003064 Rev02
©2026 Legrand | AV
www.legrandav.com
03/2026