

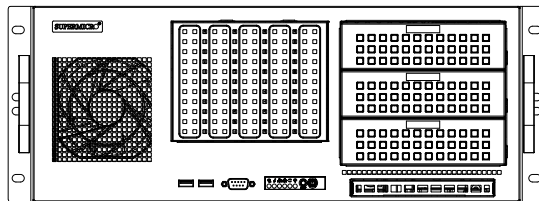

SC842

CHASSIS SERIES

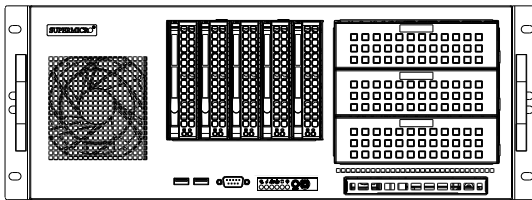

SC842i-500B

SC842TQ-665B

SC842TQ-865B

SC842XTQ-R606B

USER'S MANUAL

2.0a

The information in this User's Manual has been carefully reviewed and is believed to be accurate. The vendor assumes no responsibility for any inaccuracies that may be contained in this document, makes no commitment to update or to keep current the information in this manual, or to notify any person or organization of the updates. **Please Note: For the most up-to-date version of this manual, please see our web site at www.supermicro.com.**

Super Micro Computer, Inc. ("Supermicro") reserves the right to make changes to the product described in this manual at any time and without notice. This product, including software and documentation, is the property of Supermicro and/or its licensors, and is supplied only under a license. Any use or reproduction of this product is not allowed, except as expressly permitted by the terms of said license.

IN NO EVENT WILL SUPERMICRO BE LIABLE FOR DIRECT, INDIRECT, SPECIAL, INCIDENTAL, SPECULATIVE OR CONSEQUENTIAL DAMAGES ARISING FROM THE USE OR INABILITY TO USE THIS PRODUCT OR DOCUMENTATION, EVEN IF ADVISED OF THE POSSIBILITY OF SUCH DAMAGES. IN PARTICULAR, SUPERMICRO SHALL NOT HAVE LIABILITY FOR ANY HARDWARE, SOFTWARE, OR DATA STORED OR USED WITH THE PRODUCT, INCLUDING THE COSTS OF REPAIRING, REPLACING, INTEGRATING, INSTALLING OR RECOVERING SUCH HARDWARE, SOFTWARE, OR DATA.

Any disputes arising between manufacturer and customer shall be governed by the laws of Santa Clara County in the State of California, USA. The State of California, County of Santa Clara shall be the exclusive venue for the resolution of any such disputes. Super Micro's total liability for all claims will not exceed the price paid for the hardware product.

California Best Management Practices Regulations for Perchlorate Materials: This Perchlorate warning applies only to products containing CR (Manganese Dioxide) Lithium coin cells. "Perchlorate Material-special handling may apply. See www.dtsc.ca.gov/hazardouswaste/perchlorate"

WARNING: Handling of lead solder materials used in this product may expose you to lead, a chemical known to the State of California to cause birth defects and other reproductive harm.

Manual Revision 2.0a
Release Date: April 13, 2015

Unless you request and receive written permission from Super Micro Computer, Inc., you may not copy any part of this document.

Information in this document is subject to change without notice. Other products and companies referred to herein are trademarks or registered trademarks of their respective companies or mark holders.

Copyright © 2014 by Super Micro Computer, Inc.
All rights reserved.

Printed in the United States of America

Preface

About This Manual

This manual is written for professional system integrators and PC technicians. It provides information for the installation and use of the SC842 chassis. Installation and maintenance should be performed by experienced technicians only.

Supermicro's SC842 4U chassis features a unique and highly-optimized design for single and dual Intel/AMD processors. The chassis is equipped with a 500, R600, 665 or 865 Watt high-efficiency power supply. High-performance fans provide ample optimized cooling for the system. The chassis supports up to five 3.5" SAS/SATA hard drives which offer maximum storage capacity in a 4U form factor.

This document lists compatible parts available when this document was published. Always refer to the our Web site for updates on supported parts and configurations.

Manual Organization

Chapter 1 Introduction

The first chapter provides a checklist of the main components included with this chassis and describes the primary features of the SC842 chassis. This chapter also includes contact information.

Chapter 2 Standardized Warning Statements for AC/DC Systems

This chapter lists warnings, precautions, and system safety. You should thoroughly familiarize yourself with this chapter for a general overview of safety precautions that should be followed before installing and servicing this chassis.

Chapter 3 Chassis Components

Refer here for details on this chassis model including the fans, hard drives and other components.

Chapter 4 System Interface

Chapter 4 provides details on the system interface, which includes the functions and information provided by the control panel on the chassis as well as other LEDs located throughout the system.

Chapter 5 Chassis Setup and Maintenance

Refer to this chapter for detailed information on this chassis. You should follow the procedures given in this chapter when installing, removing, or reconfiguring your chassis.

Chapter 6 Rack Installation

This chapter details information on installing the chassis into a rack. You should follow the procedures given in this chapter when installing, removing or reconfiguring your chassis in a rack environment.

Appendix A SC842 Chassis Cables

Appendix B SC842 Power Supply Specifications

Appendix C BPN-SAS-842TQ Backplane Specifications

Table of Contents

Chapter 1 Introduction

1-1	Overview	1-1
1-2	Shipping List.....	1-1
	Part Numbers.....	1-1
1-3	Chassis Features	1-2
	Hot-Swappable Hard Drives.....	1-2
	Internal Hard Drives	1-2
	PCI Slots	1-2
	Peripheral Drives.....	1-2
	Other Features	1-2
1-4	Contacting Supermicro.....	1-3

Chapter 2 Standardized Warning Statements for AC/DC Systems

2-1	About Standardized Warning Statements.....	2-1
	Warning Definition	2-1
	Installation Instructions.....	2-4
	Circuit Breaker	2-5
	Power Disconnection Warning	2-6
	Equipment Installation.....	2-8
	Restricted Area.....	2-9
	Battery Handling.....	2-10
	Redundant Power Supplies	2-12
	Backplane Voltage	2-13
	Comply with Local and National Electrical Codes	2-14
	Product Disposal.....	2-15
	Hot Swap Fan Warning.....	2-16
	DC Power Supply	2-18
	DC Power Disconnection.....	2-20
	Hazardous Voltage or Energy Present on DC Power Terminals.....	2-21

Chapter 3 Chassis Components

3-1	Overview	3-1
3-2	Components.....	3-1
	Hard Drives and Peripheral Drives	3-1
	Fans	3-1
	Mounting Rails (Optional)	3-1
	Power Supply.....	3-1
3-3	Where to get Replacement Components.....	3-2

Chapter 4 System Interface

4-1	Overview	4-1
4-2	Control Panel Buttons	4-2
4-3	Control Panel LEDs	4-2
4-4	Drive Carrier LEDs	4-4

Chapter 5 Chassis Setup and Maintenance

5-1	Overview	5-1
5-2	Removing the Chassis Cover	5-2
5-3	Installing and Removing Hard Drives	5-3
	Removing Hard Drive Carriers (SC842TQ Series).....	5-3
	Installing a Drive into the Drive Carrier (SC842TQ Series).....	5-4
	Installing Hard Drive Carriers (SC842TQ Series).....	5-5
	Removing the Hard Drive Cage (SC842i Series).....	5-6
	Installing Hard Drives into the Cage (SC842i Series)	5-7
	Installing the Hard Drive Cage (SC842i Series).....	5-8
5-4	Installing an I/O Shield.....	5-9
5-5	Installing the Motherboard	5-10
	Permanent and Optional Standoffs.....	5-10
	Expansion Card Setup	5-12
	Installing the Rear System Fans.....	5-13
	Checking the Server's Airflow	5-14
5-6	Power Supply	5-15
	Replacing the Power Supply.....	5-15
	Installing the DVD-ROM and Peripheral Drive	5-16

Chapter 6 Rack Installation

6-1	Overview	6-1
6-2	Unpacking the System	6-1
6-3	Preparing for Setup.....	6-1
	Choosing a Setup Location.....	6-1
	Rack Precautions	6-2
	General Server Precautions.....	6-2
	Rack Mounting Considerations	6-3
	Ambient Operating Temperature	6-3
	Reduced Airflow	6-3
	Mechanical Loading	6-3
	Circuit Overloading.....	6-3
	Reliable Ground	6-3
6-4	Rack Mounting	6-4

	Rack Mounting Overview	6-4
	Mounting the Chassis in an Open (Telco) Style Rack	6-4
6-5	Rack Mounting with the Optional Rail System	6-5
	Rail System Overview	6-5
	Separating the Sections of the Rack Rails	6-5
	Installing the Inner Rails	6-6
	Outer Rack Rails	6-7

Appendix A SC842 Chassis Cables

Appendix B SC842 Power Supply Specifications

Appendix C BPN-SAS-842TQ Backplane Specifications

Notes

Chapter 1

Introduction

1-1 Overview

Supermicro's SC842 4U chassis features a unique and highly-optimized design. The chassis is equipped with a high-efficiency power supply. High-performance fans provide ample optimized cooling. Up to five 3.5" drives provide maximum storage capacity in a 4U form factor.

1-2 Shipping List

Part Numbers

Please visit the Supermicro website for the latest shipping lists and part numbers for your particular chassis model at www.supermicro.com.

SC842 Chassis Series			
Model	HDD	PCI Slots	Power Supply
SC842i-500B	5x 3.5" internal fixed SAS/SATA drives	7x FF	500W
SC842TQ-665B	5x 3.5" hot swap SAS/SATA drives	7x FF	665W
SC842TQ-865B	5x 3.5" hot swap SAS/SATA drives	7x FF	865W
SC842XTQ-R606B	5x 3.5" hot swap SAS/SATA drives	7x FF, 4x FH	600W Redundant (Platinum)

Legend:

FH: Full-height, half-length PCI slots

FF: Full-height, full-length PCI slots.

1-3 Chassis Features

The SC842 high-performance chassis includes the following features:

Hot-Swappable Hard Drives

The SC842TQ model chassis features hard drive bays which supports up to five hot-swappable 3.5" SAS/SATA hard drives. Once set up correctly, hot-swappable drives can be removed without powering down the server. In addition, these drives support SES2 (SAS/SATA). 3.5" hard drives are sold separately.

Internal Hard Drives

The SC842i /TQ model chassis support five internally mounted 3.5" SAS/SATA hard drives. In the unlikely event of a hard drive failure, the system must be powered down and disconnected from any power source before removing these hard drives.

PCI Slots

SC842i/TQ chassis includes seven full-height, full-length PCI slots for expansion cards. SC842XTQ chassis includes eleven full-height, full-length I/O PCI slots.

Peripheral Drives

Each SC842 chassis supports one slim DVD drive and up to three 5-1/4" peripheral drives.

Other Features

Other onboard features are included to promote system health. These include up to two rear cooling fans, one front cooling fan, a convenient power switch, reset button, and LED indicators.

1-4 Contacting Supermicro

Headquarters

Address: Super Micro Computer, Inc.
980 Rock Ave.
San Jose, CA 95131 U.S.A.

Tel: +1 (408) 503-8000

Fax: +1 (408) 503-8008

Email: marketing@supermicro.com (General Information)
support@supermicro.com (Technical Support)

Website: www.supermicro.com

Europe

Address: Super Micro Computer B.V.
Het Sterrenbeeld 28, 5215 ML
's-Hertogenbosch, The Netherlands

Tel: +31 (0) 73-6400390

Fax: +31 (0) 73-6416525

Email: sales@supermicro.nl (General Information)
support@supermicro.nl (Technical Support)
rma@supermicro.nl (Customer Support)

Website: www.supermicro.nl

Asia-Pacific

Address: Super Micro Computer, Inc.
3F, No. 150, Jian 1st Rd.
Zhonghe Dist., New Taipei City 235
Taiwan (R.O.C)

Tel: +886-(2) 8226-3990

Fax: +886-(2) 8226-3992

Email: support@supermicro.com.tw

Website: www.supermicro.com.tw

Notes

Chapter 2

Standardized Warning Statements for AC/DC Systems

2-1 About Standardized Warning Statements

The following statements are industry standard warnings, provided to warn the user of situations which have the potential for bodily injury. Should you have questions or experience difficulty, contact Supermicro's Technical Support department for assistance. Only certified technicians should attempt to install or configure components.

Read this appendix in its entirety before installing or configuring components in the Supermicro chassis.

These warnings may also be found on our web site at http://www.supermicro.com/about/policies/safety_information.cfm.

Warning Definition



Warning!

This warning symbol means danger. You are in a situation that could cause bodily injury. Before you work on any equipment, be aware of the hazards involved with electrical circuitry and be familiar with standard practices for preventing accidents.

警告の定義

この警告サインは危険を意味します。

人身事故につながる可能性がありますので、いずれの機器でも動作させる前に、電気回路に含まれる危険性に注意して、標準的な事故防止策に精通して下さい。

此警告符号代表危險。

您正處於可能受到嚴重傷害的工作環境中。在您使用設備開始工作之前，必須充分意識到觸電的危險，並熟練掌握防止事故發生的標準工作程序。請根據每項警告結尾的聲明號碼找到此設備的安全性警告說明的翻譯文本。

此警告符號代表危險。

您正處於可能身體可能會受損傷的工作環境中。在您使用任何設備之前，請注意觸電的危險，並且要熟悉預防事故發生的標準工作程序。請依照每一注意事項後的號碼找到相關的翻譯說明內容。

Warnung

WICHTIGE SICHERHEITSHINWEISE

Dieses Warnsymbol bedeutet Gefahr. Sie befinden sich in einer Situation, die zu Verletzungen führen kann. Machen Sie sich vor der Arbeit mit Geräten mit den Gefahren elektrischer Schaltungen und den üblichen Verfahren zur Vorbeugung vor Unfällen vertraut. Suchen Sie mit der am Ende jeder Warnung angegebenen Anweisungsnummer nach der jeweiligen Übersetzung in den übersetzten Sicherheitshinweisen, die zusammen mit diesem Gerät ausgeliefert wurden.

BEWAHREN SIE DIESE HINWEISE GUT AUF.

INSTRUCCIONES IMPORTANTES DE SEGURIDAD

Este símbolo de aviso indica peligro. Existe riesgo para su integridad física. Antes de manipular cualquier equipo, considere los riesgos de la corriente eléctrica y familiarícese con los procedimientos estándar de prevención de accidentes. Al final de cada advertencia encontrará el número que le ayudará a encontrar el texto traducido en el apartado de traducciones que acompaña a este dispositivo.

GUARDE ESTAS INSTRUCCIONES.

IMPORTANTES INFORMATIONS DE SÉCURITÉ

Ce symbole d'avertissement indique un danger. Vous vous trouvez dans une situation pouvant entraîner des blessures ou des dommages corporels. Avant de travailler sur un équipement, soyez conscient des dangers liés aux circuits électriques et familiarisez-vous avec les procédures couramment utilisées pour éviter les accidents. Pour prendre connaissance des traductions des avertissements figurant dans les consignes de sécurité traduites qui accompagnent cet appareil, référez-vous au numéro de l'instruction situé à la fin de chaque avertissement.

CONSERVEZ CES INFORMATIONS.

תקנת הצהרות אזהרה

הצהרות הבאות הן אזהרות על פי תקני התעשייה, על מנת להזהיר את המשתמש מפני חבלה פיזית אפשרית. במידה ויש שאלות או היתקלות בבעיה כלשהי, יש ליצור קשר עם מחלקת תמיכה טכנית של סופרמיקרו. טכנאים מוסמכים בלבד רשאים להתקין או להגדיר את הרכיבים.

יש לקרוא את הנספח במלואו לפני התקנת או הגדרת הרכיבים במארוזי סופרמיקרו.

تحذير! هذا الرمز يعني خطر انك في حالة يمكن أن تتسبب في اصابة جسدية .
قبل أن تعمل على أي معدات، كن على علم بالمخاطر الناجمة عن الدوائر
الكهربائية
وكن على دراية بالممارسات الوقائية لمنع وقوع أي حوادث
استخدم رقم البيان المنصوص في نهاية كل تحذير للعثور ترجمتها

안전을 위한 주의사항

경고!

이 경고 기호는 위험이 있음을 알려 줍니다. 작업자의 신체에 부상을 야기 할 수 있는 상태에 있게 됩니다. 모든 장비에 대한 작업을 수행하기 전에 전기회로와 관련된 위험요소들을 확인하시고 사전에 사고를 방지할 수 있도록 표준 작업질차를 준수해 주시기 바랍니다.

해당 번역문을 찾기 위해 각 경고의 마지막 부분에 제공된 경고문 번호를 참조하십시오

BELANGRIJKE VEILIGHEIDSINSTRUCTIES

Dit waarschuwings symbool betekent gevaar. U verkeert in een situatie die lichamelijk letsel kan veroorzaken. Voordat u aan enige apparatuur gaat werken, dient u zich bewust te zijn van de bij een elektrische installatie betrokken risico's en dient u op de hoogte te zijn van de standaard procedures om ongelukken te voorkomen. Gebruik de nummers aan het eind van elke waarschuwing om deze te herleiden naar de desbetreffende locatie.

BEWAAR DEZE INSTRUCTIES

Installation Instructions



Warning!

Read the installation instructions before connecting the system to the power source.

設置手順書

システムを電源に接続する前に、設置手順書をお読み下さい。

警告

将此系统连接电源前，请先阅读安装说明。

警告

將系統與電源連接前，請先閱讀安裝說明。

Warnung

Vor dem Anschließen des Systems an die Stromquelle die Installationsanweisungen lesen.

¡Advertencia!

Lea las instrucciones de instalación antes de conectar el sistema a la red de alimentación.

Attention

Avant de brancher le système sur la source d'alimentation, consulter les directives d'installation.

יש לקרוא את הוראות התקנה לפני חיבור המערכת למקור מתח.

اقرأ إرشادات التركيب قبل توصيل النظام إلى مصدر للطاقة

주의!

시스템을 전원에 연결하기 전에 설치 안내를 읽어주십시오.

Waarschuwing

Raadpleeg de installatie-instructies voordat u het systeem op de voedingsbron aansluit.

Circuit Breaker



Warning!

This product relies on the building's installation for short-circuit (overcurrent) protection. Ensure that the protective device is rated not greater than: 250 V, 20 A.

サーキット・ブレーカー

この製品は、短絡(過電流)保護装置がある建物での設置を前提としています。

保護装置の定格が60V、20Aを超えないことを確認下さい。

警告

此产品的短路(过载电流)保护由建筑物的供电系统提供,确保短路保护设备的额定电流不大于600V,20A。

警告

此产品的短路(过载电流)保护由建筑物的供电系统提供,确保短路保护设备的额定电流不大于60V,20A。

Warnung

Dieses Produkt ist darauf angewiesen, dass im Gebäude ein Kurzschluss- bzw. Überstromschutz installiert ist. Stellen Sie sicher, dass der Nennwert der Schutzvorrichtung nicht mehr als: 60V, 20A beträgt.

¡Advertencia!

Este equipo utiliza el sistema de protección contra cortocircuitos (o sobrecorrientes) del edificio. Asegúrese de que el dispositivo de protección no sea superior a: 60V, 20A.

Attention

Pour ce qui est de la protection contre les courts-circuits (surtension), ce produit dépend de l'installation électrique du local. Vérifiez que le courant nominal du dispositif de protection n'est pas supérieur à :60V, 20A.

هذا المنتج يعتمد على معدات الحماية من الدوائر القصيرة التي تم تثبيتها في
المبنى

경고!

이 제품은 전원의 단락(과전류)방지에 대해서 전적으로 건물의 관련 설비에 의존합니다. 보호장치의 정격이 반드시 60V(볼트), 20A(암페어)를 초과하지 않도록 해야 합니다.

Waarschuwing

Dit product is afhankelijk van de kortsluitbeveiliging (overspanning) van uw elektrische installatie. Controleer of het beveiligde apparaat niet groter gedimensioneerd is dan 60V, 20A.

Power Disconnection Warning



Warning!

The system must be disconnected from all sources of power and the power cord removed from the power supply module(s) before accessing the chassis interior to install or remove system components.

電源切斷の警告

システムコンポーネントの取り付けまたは取り外しのために、シャーシ内部にアクセスするには、

システムの電源はすべてのソースから切斷され、電源コードは電源モジュールから取り外す必要があります。

警告

在你打开机箱并安装或移除内部器件前，必须将系统完全断电，并移除电源线。

警告

在您打開機殼安裝或移除內部元件前，必須將系統完全斷電，並移除電源線。

Warnung

Das System muss von allen Quellen der Energie und vom Netzanschlusskabel getrennt sein, das von den Spg.Versorgungsteilmodulen entfernt wird, bevor es auf den Chassisinnenraum zurückgreift, um Systemsbestandteile anzubringen oder zu entfernen.

¡Advertencia!

El sistema debe ser disconnected de todas las fuentes de energía y del cable eléctrico quitado de los módulos de fuente de alimentación antes de tener acceso el interior del chasis para instalar o para quitar componentes de sistema.

Attention

Le système doit être débranché de toutes les sources de puissance ainsi que de son cordon d'alimentation secteur avant d'accéder à l'intérieur du châssis pour installer ou enlever des composants de système.

אזהרה!

יש לנתק את המערכת מכל מקורות החשמל ויש להסיר את כבל החשמלי מהספק לפני גישה לחלק הפנימי של המארז לצורך התקנת או הסרת רכיבים.

يجب فصل النظام من جميع مصادر الطاقة وإزالة سلك الكهرباء من وحدة امداد الطاقة قبل الوصول إلى المناطق الداخلية للهيكल لتثبيت أو إزالة مكونات الجهاز

경고!

시스템에 부품들을 장착하거나 제거하기 위해서는 새시 내부에 접근하기 전에 반드시 전원 공급장치로부터 연결되어있는 모든 전원과 전기코드를 분리해주어야 합니다.

Waarschuwing

Voordat u toegang neemt tot het binnenwerk van de behuizing voor het installeren of verwijderen van systeem onderdelen, dient u alle spanningsbronnen en alle stroomkabels aangesloten op de voeding(en) van de behuizing te verwijderen

Equipment Installation



Warning!

Only trained and qualified personnel should be allowed to install, replace, or service this equipment.

機器の設置

トレーニングを受け認定された人だけがこの装置の設置、交換、またはサービスを許可されています。

警告

只有经过培训且具有资格的人员才能进行此设备的安装、更换和维修。

警告

只有經過受訓且具資格人員才可安裝、更換與維修此設備。

Warnung

Das Installieren, Ersetzen oder Bedienen dieser Ausrüstung sollte nur geschultem, qualifiziertem Personal gestattet werden.

¡Advertencia!

Solamente el personal calificado debe instalar, reemplazar o utilizar este equipo.

Attention

Il est vivement recommandé de confier l'installation, le remplacement et la maintenance de ces équipements à des personnels qualifiés et expérimentés.

אזהרה!

צוות מוסמך בלבד רשאי להתקין, להחליף את הציוד או לתת שירות עבור הציוד.

يجب أن يسمح فقط للموظفين المؤهلين والمدربين لتثبيت واستبدال أو خدمة هذا الجهاز

경고!

훈련을 받고 공인된 기술자만이 이 장비의 설치, 교체 또는 서비스를 수행할 수 있습니다.

Waarschuwing

Deze apparatuur mag alleen worden geïnstalleerd, vervangen of hersteld door geschoold en gekwalificeerd personeel.

Restricted Area



Warning!

This unit is intended for installation in restricted access areas. A restricted access area can be accessed only through the use of a special tool, lock and key, or other means of security. (This warning does not apply to workstations).

アクセス制限区域

このユニットは、アクセス制限区域に設置されることを想定しています。

アクセス制限区域は、特別なツール、鍵と錠前、その他のセキュリティの手段を用いてのみ出入りが可能です。

警告

此部件应安装在限制进出的场所，限制进出的场所指只能通过使用特殊工具、锁和钥匙或其它安全手段进出的场所。

警告

此裝置僅限安裝於進出管制區域，進出管制區域係指僅能以特殊工具、鎖頭及鑰匙或其他安全方式才能進入的區域。

Warnung

Diese Einheit ist zur Installation in Bereichen mit beschränktem Zutritt vorgesehen. Der Zutritt zu derartigen Bereichen ist nur mit einem Spezialwerkzeug, Schloss und Schlüssel oder einer sonstigen Sicherheitsvorkehrung möglich.

¡Advertencia!

Esta unidad ha sido diseñada para instalación en áreas de acceso restringido. Sólo puede obtenerse acceso a una de estas áreas mediante la utilización de una herramienta especial, cerradura con llave u otro medio de seguridad.

Attention

Cet appareil doit être installée dans des zones d'accès réservés. L'accès à une zone d'accès réservé n'est possible qu'en utilisant un outil spécial, un mécanisme de verrouillage et une clé, ou tout autre moyen de sécurité.

אזור עם גישה מוגבלת

אזהרה!

יש להתקין את היחידה באזורים שיש בהם הגבלת גישה. הגישה ניתנת בעזרת כלי אבטחה בלבד (מפתח, מנעול וכד').

تم تخصيص هذه الوحدة لت تركيبها في مناطق محظورة . يمكن الوصول إلى منطقة محظورة فقط من خلال استخدام أداة خاصة، قفل ومفتاح أو أي وسيلة أخرى للالأمان

경고!

이 장치는 접근이 제한된 구역에 설치하도록 되어 있습니다. 특수도구, 잠금 장치 및 키, 또는 기타 보안 수단을 통해서만 접근 제한 구역에 들어갈 수 있습니다.

Waarschuwing

Dit apparaat is bedoeld voor installatie in gebieden met een beperkte toegang. Toegang tot dergelijke gebieden kunnen alleen verkregen worden door gebruik te maken van speciaal gereedschap, slot en sleutel of andere veiligheidsmaatregelen.

Battery Handling



Warning!

There is the danger of explosion if the battery is replaced incorrectly. Replace the battery only with the same or equivalent type recommended by the manufacturer. Dispose of used batteries according to the manufacturer's instructions

電池の取り扱い

電池交換が正しく行われなかった場合、破裂の危険性があります。交換する電池はメーカーが推奨する型、または同等のものを使用下さい。使用済電池は製造元の指示に従って処分して下さい。

警告

電池更換不當會有爆炸危險。請只使用同類電池或製造商推薦的功能相當的電池更換原有電池。請按製造商的說明處理廢舊電池。

警告

電池更換不當會有爆炸危險。請使用製造商建議之相同或功能相當的電池更換原有電池。請按照製造商的說明指示處理廢棄舊電池。

Warnung

Bei Einsetzen einer falschen Batterie besteht Explosionsgefahr. Ersetzen Sie die Batterie nur durch den gleichen oder vom Hersteller empfohlenen Batterietyp. Entsorgen Sie die benutzten Batterien nach den Anweisungen des Herstellers.

Attention

Danger d'explosion si la pile n'est pas remplacée correctement. Ne la remplacer que par une pile de type semblable ou équivalent, recommandée par le fabricant. Jeter les piles usagées conformément aux instructions du fabricant.

¡Advertencia!

Existe peligro de explosión si la batería se reemplaza de manera incorrecta. Reemplazar la batería exclusivamente con el mismo tipo o el equivalente recomendado por el fabricante. Desechar las baterías gastadas según las instrucciones del fabricante.

אזהרה!

קיימת סכנת פיצוץ של הסוללה במידה והוחלפה בדרך לא תקינה. יש להחליף את הסוללה בסוג התואם מחברת יצרן מומלצת.

סילוק הסוללות המשומשות יש לבצע לפי הוראות היצרן.

هناك خطر من انفجار في حالة استبدال البطارية بطريقة غير صحيحة فعليك استبدال البطارية فقط بنفس النوع أو ما يعادلها كما أوصت به الشركة المصنعة تخلص من البطاريات المستعملة وفقا لتعليمات الشركة الصانعة

경고!

배터리가 올바르게 교체되지 않으면 폭발의 위험이 있습니다. 기존 배터리와 동일하거나 제조사에서 권장하는 동등한 종류의 배터리로만 교체해야 합니다. 제조사의 안내에 따라 사용된 배터리를 처리하여 주십시오.

Waarschuwing

Er is ontploffingsgevaar indien de batterij verkeerd vervangen wordt. Vervang de batterij slechts met hetzelfde of een equivalent type die door de fabrikant aanbevolen wordt. Gebruikte batterijen dienen overeenkomstig fabrieksvoorschriften afgevoerd te worden.

Redundant Power Supplies



Warning!

This unit might have more than one power supply connection. All connections must be removed to de-energize the unit.

冗長電源装置

このユニットは複数の電源装置が接続されている場合があります。
ユニットの電源を切るためには、すべての接続を取り外さなければなりません。

警告

此部件连接的电源可能不止一个，必须将所有电源断开才能停止给该部件供电。

警告

此装置连接的电源可能不只一个，必须切断所有电源才能停止对该装置的供电。

Warnung

Dieses Gerät kann mehr als eine Stromzufuhr haben. Um sicherzustellen, dass der Einheit kein Strom zugeführt wird, müssen alle Verbindungen entfernt werden.

¡Advertencia!

Puede que esta unidad tenga más de una conexión para fuentes de alimentación. Para cortar por completo el suministro de energía, deben desconectarse todas las conexiones.

Attention

Cette unité peut avoir plus d'une connexion d'alimentation. Pour supprimer toute tension et tout courant électrique de l'unité, toutes les connexions d'alimentation doivent être débranchées.

אם קיים יותר מספק אחד

אזהרה!

ליחידה יש יותר מחיבור אחד של ספק. יש להסיר את כל החיבורים על מנת לרוקן את היחידה.

قد يكون لهذا الجهاز عدة اتصالات بوحدات امداد الطاقة.
يجب إزالة كافة الاتصالات لعزل الوحدة عن الكهرباء

경고!

이 장치에는 한 개 이상의 전원 공급 단자가 연결되어 있을 수 있습니다. 이 장치에 전원을 차단하기 위해서는 모든 연결 단자를 제거해야만 합니다.

Waarschuwing

Deze eenheid kan meer dan één stroomtoevoeraansluiting bevatten. Alle aansluitingen dienen verwijderd te worden om het apparaat stroomloos te maken.

Backplane Voltage



Warning!

Hazardous voltage or energy is present on the backplane when the system is operating. Use caution when servicing.

バックプレーンの電圧

システムの稼働中は危険な電圧または電力が、バックプレーン上にかかっています。

修理する際にはご注意ください。

警告

当系統正在进行时，背板上有很危险的电压或能量，进行维修时务必小心。

警告

當系統正在進行時，背板上有危險的電壓或能量，進行維修時務必小心。

Warnung

Wenn das System in Betrieb ist, treten auf der Rückwandplatine gefährliche Spannungen oder Energien auf. Vorsicht bei der Wartung.

¡Advertencia!

Cuando el sistema está en funcionamiento, el voltaje del plano trasero es peligroso. Tenga cuidado cuando lo revise.

Attention

Lorsque le système est en fonctionnement, des tensions électriques circulent sur le fond de panier. Prendre des précautions lors de la maintenance.

מתח בפנל האחורי

אזהרה!
קיימת סכנת מתח בפנל האחורי בזמן תפעול המערכת. יש להיזהר במהלך
העבודה.

هناك خطر من التيار الكهربائي أو الطاقة الموجودة على اللوحة
عندما يكون النظام يعمل كن حذرا عند خدمة هذا الجهاز

경고!

시스템이 동작 중일 때 후면판 (Backplane)에는 위험한 전압이나 에너지가 발생
합니다. 서비스 작업 시 주의하십시오.

Waarschuwing

Een gevaarlijke spanning of energie is aanwezig op de backplane wanneer het
systeem in gebruik is. Voorzichtigheid is geboden tijdens het onderhoud.

Comply with Local and National Electrical Codes



Warning!

Installation of the equipment must comply with local and national electrical codes.

地方および国の電気規格に準拠

機器の取り付けはその地方および国の電気規格に準拠する必要があります。

警告

设备安装必须符合本地与本国电气法规。

警告

設備安裝必須符合本地與本國電氣法規。

Warnung

Die Installation der Geräte muss den Sicherheitsstandards entsprechen.

¡Advertencia!

La instalación del equipo debe cumplir con las normas de electricidad locales y
nacionales.

Attention

L'équipement doit être installé conformément aux normes électriques nationales et locales.

תיאום חוקי החשמל הארצי

אזהרה!

התקנת הציוד חייבת להיות תואמת לחוקי החשמל המקומיים והארציים.

تركيب المعدات الكهربائية يجب أن يمتثل للقوانين المحلية والوطنية المتعلقة بالكهرباء

경고!

현 지역 및 국가의 전기 규정에 따라 장비를 설치해야 합니다.

Waarschuwing

Bij installatie van de apparatuur moet worden voldaan aan de lokale en nationale elektriciteitsvoorschriften.

Product Disposal



Warning!

Ultimate disposal of this product should be handled according to all national laws and regulations.

製品の廃棄

この製品を廃棄処分する場合、国の関係する全ての法律・条例に従い処理する必要があります。

警告

本产品的废弃处理应根据所有国家的法律和规章进行。

警告

本產品的廢棄處理應根據所有國家的法律和規章進行。

Warnung

Die Entsorgung dieses Produkts sollte gemäß allen Bestimmungen und Gesetzen des Landes erfolgen.

¡Advertencia!

Al deshacerse por completo de este producto debe seguir todas las leyes y reglamentos nacionales.

Attention

La mise au rebut ou le recyclage de ce produit sont généralement soumis à des lois et/ou directives de respect de l'environnement. Renseignez-vous auprès de l'organisme compétent.

סילוק המוצר

אזהרה!

סילוק סופי של מוצר זה חייב להיות בהתאם להנחיות וחוקי המדינה.

عند التخلص النهائي من هذا المنتج ينبغي التعامل معه وفقا لجميع القوانين واللوائح الوطنية

경고!

이 제품은 해당 국가의 관련 법규 및 규정에 따라 폐기되어야 합니다.

Waarschuwing

De uiteindelijke verwijdering van dit product dient te geschieden in overeenstemming met alle nationale wetten en reglementen.

Hot Swap Fan Warning



Warning!

The fans might still be turning when you remove the fan assembly from the chassis. Keep fingers, screwdrivers, and other objects away from the openings in the fan assembly's housing.

ファン・ホットスワップの警告

シャーシから冷却ファン装置を取り外した際、ファンがまだ回転している可能性があります。ファンの開口部に、指、ドライバー、およびその他のものを近づけないで下さい。

警告

当您从机架移除风扇装置，风扇可能仍在转动。小心不要将手指、螺丝起子和其他物品太靠近风扇

警告

當您從機架移除風扇裝置，風扇可能仍在轉動。小心不要將手指、螺絲起子和其他物品太靠近風扇。

Warnung

Die Lüfter drehen sich u. U. noch, wenn die Lüfterbaugruppe aus dem Chassis genommen wird. Halten Sie Finger, Schraubendreher und andere Gegenstände von den Öffnungen des Lüftergehäuses entfernt.

¡Advertencia!

Los ventiladores podran dar vuelta cuando usted quite el montaje del ventilador del chasis. Mantenga los dedos, los destornilladores y todos los objetos lejos de las aberturas del ventilador

Attention

Il est possible que les ventilateurs soient toujours en rotation lorsque vous retirez le bloc ventilateur du châssis. Prenez garde à ce que doigts, tournevis et autres objets soient éloignés du logement du bloc ventilateur.

אזהרה!

כאשר מסירים את חלקי המאוורר מהמארז, יתכן והמאווררים עדיין עובדים. יש להרחיק למרחק בטוח את האצבעות וכלי עבודה שונים מהפתחים בתוך המאוורר

من الممكن أن المراوح لا تزال تدور عند إزالة كتلة المروحة من الهيكل يجب إبقاء الأصابع ومفكات البراغي وغيرها من الأشياء بعيدا عن الفتحات في كتلة المروحة.

경고!

새시로부터 팬 조립품을 제거할 때 팬은 여전히 회전하고 있을 수 있습니다. 팬 조립품 외관의 열려있는 부분들로부터 손가락 및 스크류드라이버, 다른 물체들이 가까이 하지 않도록 배치해 주십시오.

Waarschuwing

Het is mogelijk dat de ventilator nog draait tijdens het verwijderen van het ventilatorsamenstel uit het chassis. Houd uw vingers, schroevendraaiers en eventuele andere voorwerpen uit de buurt van de openingen in de ventilatorbehuizing.

DC Power Supply



Warning!

When stranded wiring is required, use approved wiring terminations, such as closedloop or spade-type with upturned lugs. These terminations should be the appropriate size for the wires and should clamp both the insulation and conductor.

警告

より線が必要な場合、承認済みのケーブル終端(上向きの端子を備えたクローズループ型またはU字型の終端など)を使用してください。使用するワイヤーに適したサイズで、絶縁体および導体が両方ともクランプされている終端でなければなりません。

警告

需要多股佈線時，請使用經核准的佈線終端，例如閉環或鏟型接線片。這些終端的大小應適合線路，並且可以同時夾住絕緣體和導體。

警告

需要使用绞线连接时，请使用经认可的连接端子，如闭环端子或具有接线柱的铲形端子。这些端子的大小应与线缆相吻合，并且可以将绝缘部分和导体夹紧固定。

Warnung

Wenn Litzenverdrahtung erforderlich ist, sind zugelassene Verdrahtungsabschlüsse, z.B. für einen geschlossenen Regelkreis oder gabelförmig, mit nach oben gerichteten Kabelschuhen zu verwenden. Diese Abschlüsse sollten die angemessene Größe für die Drähte haben und sowohl die Isolierung als auch den Leiter festklemmen.

¡Advertencia!

Quando se necesite hilo trenzado, utilizar terminales para cables homologados, tales como las de tipo "bucle cerrado" o "espada", con las lengüetas de conexión vueltas hacia arriba. Estos terminales deberán ser del tamaño apropiado para los cables que se utilicen, y tendrán que sujetar tanto el aislante como el conductor.

Attention

Quand des fils torsadés sont nécessaires, utiliser des douilles terminales homologuées telles que celles à circuit fermé ou du type à plage ouverte avec cosses rebroussées. Ces douilles terminales doivent être de la taille qui convient aux fils et doivent être refermées sur la gaine isolante et sur le conducteur.

תקנון הצהרות אזהרה

הצהרות הבאות הן אזהרות על פי תקני התעשייה, על מנת להזהיר את המשתמש מפני חבלה פיזית אפשרית. במידה ויש שאלות או היתקלות בבעיה כלשהי, יש ליצור קשר עם מחלקת תמיכה טכנית של סופרמיקרו. טכנאים מוסמכים בלבד רשאים להתקין או להגדיר את הרכיבים.

יש לקרוא את הנספח במלואו לפני התקנת או הגדרת הרכיבים במארזי סופרמיקרו.

تحذير

كإل سأل امدختس او ،لبس ل مهب تعطقت ني ذل كإل سأل ابولطم نو كي امدنح
عونلا ةيقي قحل اءى افس أب اءى شأل وأ قق لغم قق لشم ،اهي لع قق فاومل اءان!
كإل سأل بس انملا م جحل لا نو كي تاء ان إل ا هذل يغب ني و .قبولقم تاورعلا عم
لصوم و لزعل ا نم لك حبك ب ج ي و

주의!

꼬인 배선이 요구 될 때에는 폐회로나 돌출부가 위로 튀어 나온 Spade 형태의 승인된 배선 터미네이션들을 사용하세요.

이 터미네이션들은 배선들을 위해 적절한 크기여야 하고, 절연체와 도체 모두를 고정시킬 수 있어야 합니다.

Waarschuwing

Wanneer geslagen bedrading vereist is, dient u bedrading te gebruiken die voorzien is van goedgekeurde aansluitingspunten, zoals het gesloten-lus type of het grijperschop type waarbij de aansluitpunten omhoog wijzen. Deze aansluitpunten dienen de juiste maat voor de draden te hebben en dienen zowel de isolatie als de geleider vast te klemmen.

DC Power Disconnection



Warning!

Before performing any of the following procedures, ensure that power is removed from the DC circuit.

警告

次の手順を開始する前に、DC回路から電源が切斷されていることを確認してください。

警告

進行以下任一操作程序前，請確保直流電路已斷電。

警告

請在進行以下任一操作程序前，確保直流電路的電源已經斷開。

Warnung

Vor Ausführung der folgenden Vorgänge ist sicherzustellen, daß die Gleichstromschaltung keinen Strom erhält.

¡Advertencia!

Antes de proceder con los siguientes pasos, comprobar que la alimentación del circuito de corriente continua (CC) esté cortada (OFF).

Attention

Avant de pratiquer l'une quelconque des procédures ci-dessous, vérifier que le circuit en courant continu n'est plus sous tension.

אזהרה !
לפני ביצוע אחת הפעולות הבאות, ודא כי אספקת החשמל למועגל הזרם הישר DC הינה מנותקת.

تحذير

ءاهن إكالسألأ اءاءءءساو ،للسلأ مءب ءءءقء نء ذلأ كالسألأ ابولطم نوكة اءءن ع عم عونلأ ءءقءقءءءلأ اءءءسأب ءءشألأ وأ ءءلغم ءءلءلشءم ،اءءل ع ءءقءاوملأ بسءو كالسألل بسءنءلأ مءءءلأ نوكة ءاءءءنلأ هءهل ءءبءنءو .ءبولقم ءاورعلاء لصلومو لزعلاء نم لك ءبءك

주의!

다음 절차를 수행하기 전에, 전원이 DC 회로로부터 제거되었는지를 확인해 주십시오.

Waarschuwing

Wanneer geslagen bedrading vereist is, dient u bedrading te gebruiken die voorzien is van goedgekeurde aansluitingspunten, zoals het gesloten-lus type of het grijperschop type waarbij de aansluitpunten omhoog wijzen. Deze aansluitpunten dienen de juiste maat voor de draden te hebben en dienen zowel de isolatie als de geleider vast te klemmen.

Hazardous Voltage or Energy Present on DC Power Terminals



Warning!

Hazardous voltage or energy may be present on DC power terminals. Always replace cover when terminals are not in service. Be sure uninsulated conductors are not accessible when cover is in place.

警告

直接電力端子に危険な電圧やエネルギーが発生している可能性があります。使用していない端子には常にカバーをつけてください。カバーがついているときは非絶縁形コンダクターに接触していないことを確認してください。

警告

直流電源終端可能產生危險的電壓或能量。終端不使用時，請務必蓋上機蓋。當蓋上機蓋，確認不絕緣導體無法使用。

警告

直流电源终端可能会产生危险的电压或能量。终端不使用时，请务必盖上机盖。机盖盖上后，请确保导体未绝缘部分无法使用。

Warnung

In mit Gleichstrom betriebenen Terminals kann es zu gefährlicher Spannung kommen. Die Terminals müssen abgedeckt werden, wenn sie nicht in Betrieb sind. Stellen Sie bei Benutzung der Abdeckung sicher, dass alle nicht isolierten, stromführenden Kabel abgedeckt sind.

¡Advertencia!

Puede haber energía o voltaje peligrosos en los terminales eléctricos de CC. Reemplace siempre la cubierta cuando no estén utilizándose los terminales. Asegúrese de que no haya acceso a conductores descubiertos cuando la cubierta esté colocada.

Attention

Le voltage ou l'énergie électrique des terminaux à courant continu peuvent être dangereux. Veuillez à toujours replacer le couvercle lors les terminaux ne sont pas en service. Assurez-vous que les conducteurs non isolés ne sont pas accessibles lorsque le couvercle est en place.

אזהרה!

מקור מתח מסוכן עלול להיות נוכח על הקטבים של זרם ה-DC. החלף תמיד את המכסה כאשר הקטבים לא בשימוש. ודא כי המוליכים הלא מבודדים אינם נגישים כאשר המכסה נמצא במקומו.

تحذير

لادبتسأ. ؤمصاعلا ؤق اطلأ تااطحم ىل ع ؤدوجوم نوكت ؤق اطلأ وأ ؤرطخلأ دهجلأ دق ريغ تالصلوملا هيف لكش ال امم. ؤمدخلأ يف تسيل تااطحملأ امذن ع امئاد اعاطغ هنالكم يف اعاطغلأ امذن ع اهيل لوصولأ نلكمي ال لوزعم

주의!

DC전원 단자들에 위험한 전압이나 에너지가 발생할 수 있습니다.

단말기들을 운영하지 않을 때에는 덮개로 다시 덮어 놓아 주십시오. 덮개가 제자리에 있어야만 절연되지 않은 도체들의 접근을 막을 수 있습니다.

Waarschuwing

Op DC-aansluitingspunten kunnen zich gevaarlijke voltages of energieën voordoen. Plaats altijd de afsluiting wanneer de aansluitingspunten niet worden gebruikt. Zorg ervoor dat blootliggende contactpunten niet toegankelijk zijn wanneer de afsluiting is geplaatst.

Chapter 3

Chassis Components

3-1 Overview

This chapter describes the most common components included with your chassis. Some components listed may not be included or compatible with your particular chassis model. For more information, see the installation instructions detailed later in this manual.

3-2 Components

Hard Drives and Peripheral Drives

The SC842 chassis supports up to five hot-swappable 3.5" hard drives (SC842TQ series) or up to five internal 3.5" hard drives (SC842i series), and one optional slim DVD-ROM drive and up to three 5-1/4" peripheral drives. For the latest shipping list, visit our web site at www.supermicro.com.

Fans

The SC842 chassis supports one 9 cm front cooling fan and two 8 cm rear exhaust fans. System fans for the SC842 chassis are powered from the serverboard. These fans are powered by 4-pin PWM connectors.

Mounting Rails (Optional)

The SC842 can be placed on a two-post or four-post rack for secure storage and use. To set up your rack with the optional mounting rail, follow the step-by-step instructions included in this manual.

Power Supply

Each SC842 chassis model includes a high-efficiency power supply rated at 500, R600, 665 or 865 Watts. In the unlikely event of a power supply failure, replacement is easily accomplished.

3-3 Where to get Replacement Components

Although not frequently, you may need replacement parts for your system. To ensure the highest level of professional service and technical support, we strongly recommend purchasing exclusively from our Supermicro Authorized Distributors/System Integrators/Resellers. A list of Supermicro Authorized Distributors/System Integrators/Reseller can be found at: <http://www.supermicro.com>. Click the Where to Buy link.

Chapter 4

System Interface

4-1 Overview

There are several LEDs on the control panel as well as others on the drive carriers to keep you constantly informed of the overall status of the system as well as the activity and health of specific components. SC842 models have two buttons on the chassis control panel: a reset button and an on/off switch. This chapter explains the meanings of all LED indicators and the appropriate response you may need to take.

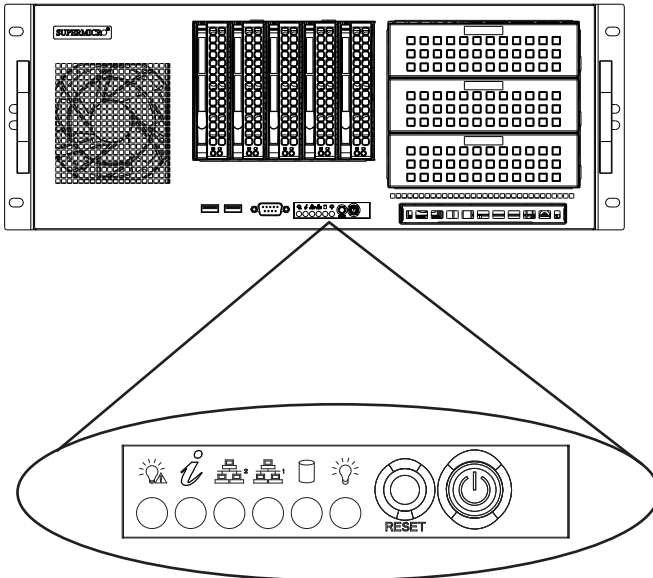

Figure 4-1. SC842 Front Panel

4-2 Control Panel Buttons

There are two push-buttons located on the front of the chassis. These are (in order from left to right), a reset button and a power on/off button.



Reset: The reset button is used to reboot the system.



Power: The main power switch is used to activate or remove power from the power supply to the server system. Turning off system power with this button removes the main power but keeps standby power supplied to the system. Therefore, you must unplug system before servicing.

4-3 Control Panel LEDs

The control panel located on the front of the SC842 chassis has six LEDs. These LEDs provide you with critical information related to different parts of the system. This section explains what each LED indicates when illuminated and any corrective action you may need to take.



Power Failure: When this LED flashes, it indicates a power failure in the power supply.



Informational LED	
Status	Description
Solid red	An overheat condition has occurred. (This may be caused by cable congestion).
Blinking red (1Hz)	Fan failure, check for an inoperative fan.
Blinking red (0.25Hz)	Power failure, check for a non-operational power supply.
Solid blue	Local UID has been activated. Use this function to locate the server in a rack mount environment.
Blinking blue (300 msec)	Remote UID is on. Use this function to identify the server from a remote location.



NIC2: Indicates network activity on LAN2 when flashing.



NIC1: Indicates network activity on LAN1 when flashing.



HDD: Indicates SAS/SATA drive and/or DVD-ROM drive activity when flashing.



Power: Indicates power is being supplied to the system's power supply units. This LED should normally be illuminated when the system is operating.

4-4 Drive Carrier LEDs

Each hard drive carrier has two LEDs.

Blue: When illuminated, this blue LED (on the front of the drive carrier) indicates drive activity. A connection to the backplane enables this LED to blink on and off when that particular drive is being accessed.

Red: The red LED to indicate a drive failure. If one of the hard drives fails, replace it with a compatible enterprise-level hard drive model.

Chapter 5

Chassis Setup and Maintenance

5-1 Overview

This chapter details the basic steps required to install components in the SC842 chassis. The only tool you will need is a Phillips head screwdriver. Print this chapter to use as a reference while setting up your chassis.

Review the warnings and precautions listed in the manual before setting up or servicing this chassis. These include information in Chapter 2 and the warnings and precautions listed in the setup instructions.

5-2 Removing the Chassis Cover

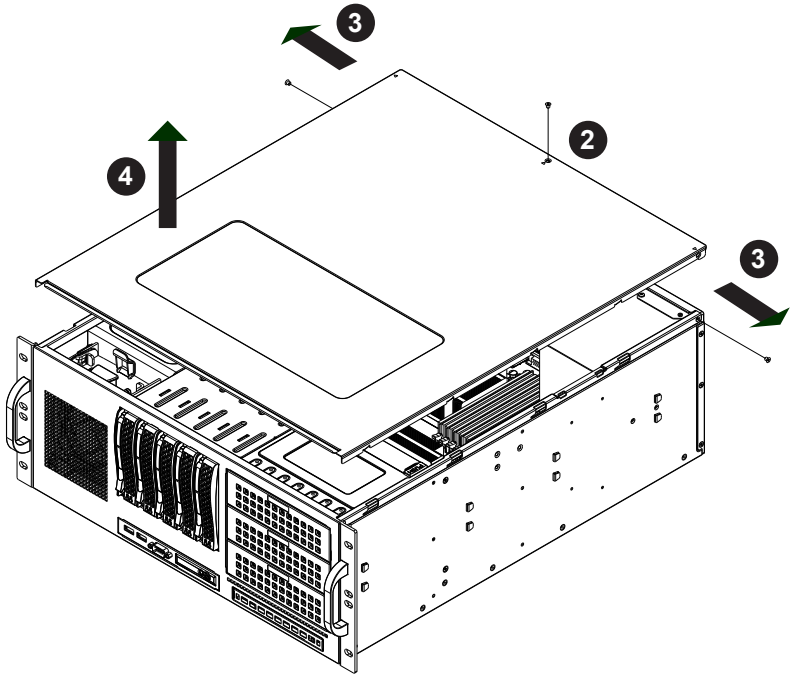

Figure 5-1. Removing the Chassis Cover

Removing the Chassis Cover

1. Power down the system and remove the power cord from the rear of the power supply. Remove the cords from both power supplies if your chassis includes a redundant power module.
2. Remove the screw at the rear of the chassis and set it aside for later use.
3. Remove the two screws on the sides of the cover and set them aside.
4. Lift the cover up and off the chassis.

Warning: Except for short periods of time, do NOT operate the chassis without the cover in place. The chassis cover must be in place to allow proper airflow and prevent overheating.

5-3 Installing and Removing Hard Drives

Hard drives are mounted in drive carriers to simplify their installation and removal from the chassis. The SC842TQ chassis supports up to five hot-swappable 3.5" hard drives in carriers which can be removed without powering down the system. The SC842i features an internal hard drive cage. The SC842i must be powered down before removing this cage.

Removing Hard Drive Carriers (SC842TQ Series)

Removing the Hard Drive and Hard Drive Carriers

1. Press the release button on the drive carrier. This extends the drive carrier handle.
2. Use the handle to pull the drive carrier out of the chassis.

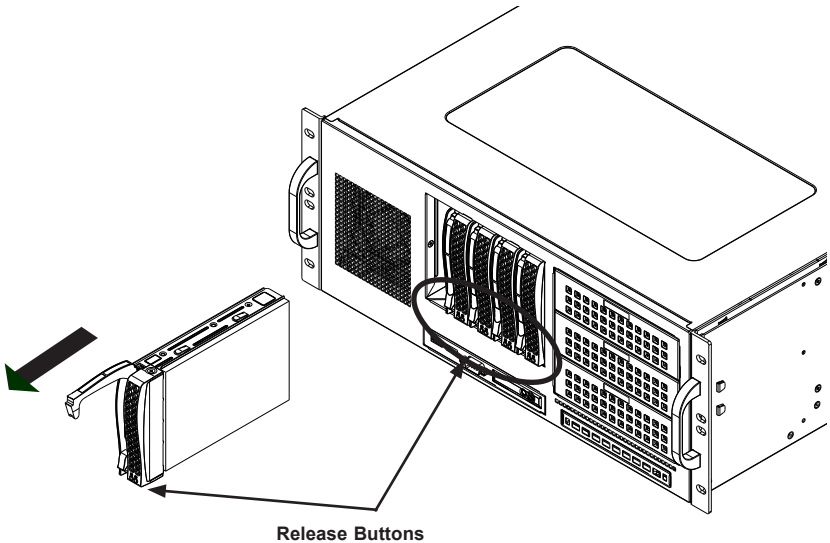

Figure 5-2. Removing the Hard Drive Carriers

Installing a Drive into the Drive Carrier (SC842TQ Series)

Installing a Hard Drive

1. Remove the two screws securing the dummy drive to the drive carrier.
2. Lift the dummy drive out of the drive carrier.
3. Place the hard drive carrier on a flat, stable surface such as a desk, table, or work bench.
4. Slide the hard drive into the carrier with the printed circuit board side facing down.
5. Carefully align the mounting holes in the hard drive and the carrier. Make sure the bottom of the hard drive and bottom of the hard drive carrier are flush.
6. Secure the hard drive using all six screws.
7. Replace the drive carrier into the chassis. Make sure to close the drive carrier using the drive carrier handle.

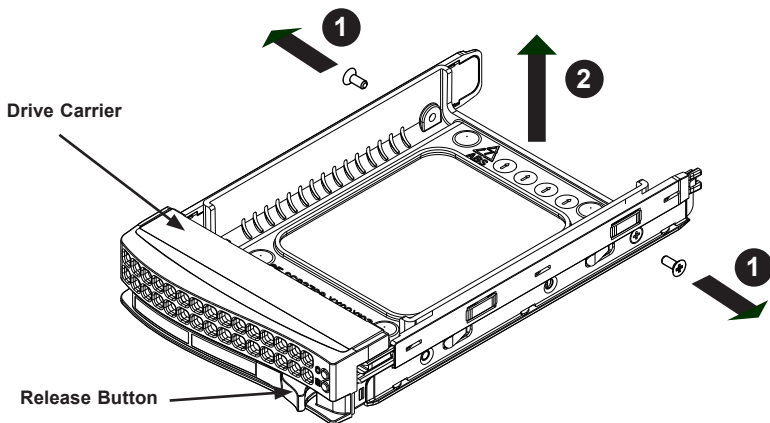

Figure 5-3. Removing the Dummy Drive from the Carrier

Warning! Enterprise level hard disk drives are recommended for use in Supermicro chassis and servers. For information on recommended HDDs, visit the Supermicro web site at www.supermicro.com.

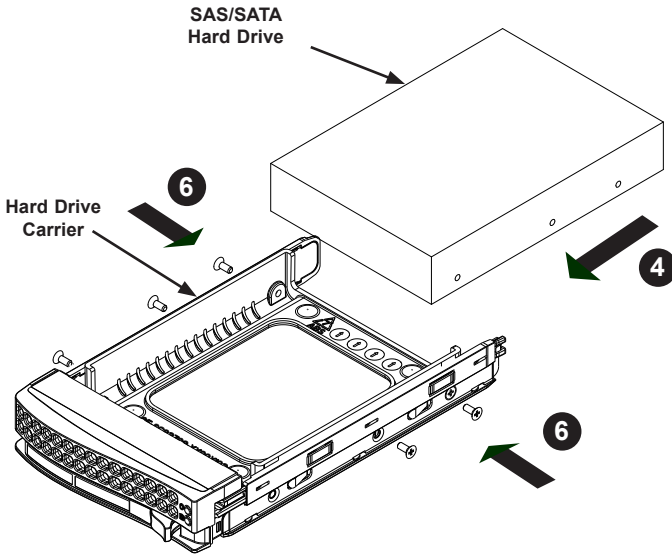

Figure 5-4. Installing a Drive into a Hard Drive Carrier

Installing Hard Drive Carriers (SC842TQ Series)

Installing the Hard Drive Carriers

1. Reinsert the hard drive carrier into the hard drive bay.
2. Gently push in the handle, which locks the drive carrier into the drive bay.

Removing the Hard Drive Cage (SC842i Series)

Removing the Hard Drive Cage

1. Power down the system and remove the power cord from the rear of the power supply. Remove the cords from both power supplies if your chassis includes a redundant power module. Remove the chassis cover as described in Section 5-2.
2. Remove the four screws securing the internal hard drive cage and bracket to the chassis as illustrated below and set them aside for later use.
3. Gently push the internal hard drive cage out through the front of the chassis.

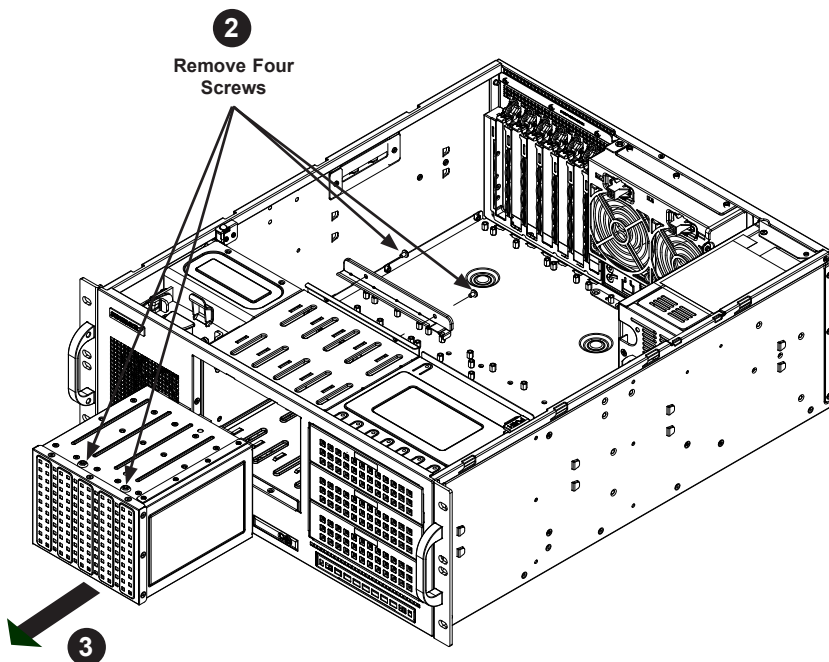

Figure 5-5. Removing the Internal HDD Cage

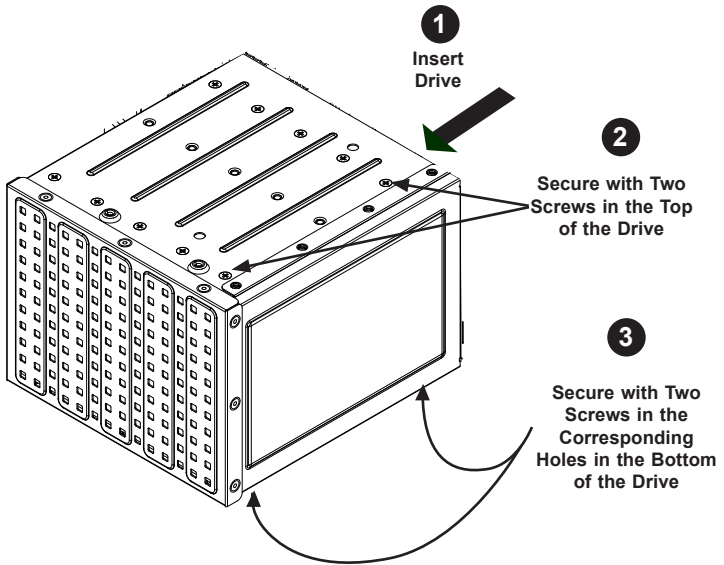

Figure 5-6. Installing Hard Drives into the Internal Hard Drive Cage

Installing Hard Drives into the Cage (SC842i Series)

Installing Drives into the Internal Hard Drive Cage

1. Insert a hard drive into the hard drive cage, aligning the holes in the drive with those in the cage.
2. Secure the drive to the top of the cage with two hard drive screws.
3. Secure the drive to the bottom of the cage with two hard drive screws.

Installing the Hard Drive Cage (SC842i Series)

Installing the Hard Drive Cage

1. Insert the hard drive cage through the front of the chassis.
2. Reinstall the four screws which were previously set aside to secure the hard drive cage and bracket to the chassis as illustrated below.
3. Plug the power cord(s) into the rear the power supply (two power supplies on redundant models) and power up the system.

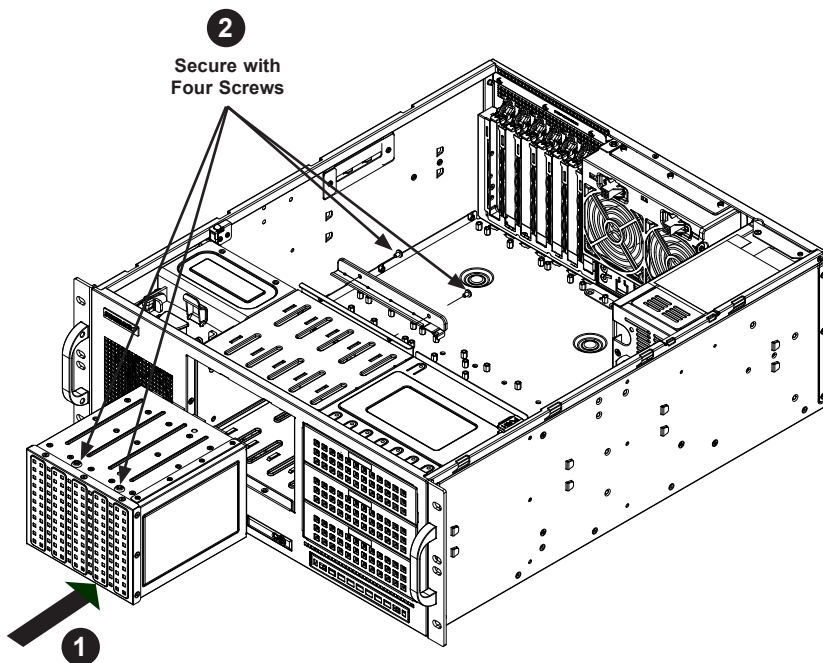

Figure 5-7. Installing the Internal HDD Cage

5-4 Installing an I/O Shield

Installing an I/O Shield

I/O shields help to hold the motherboard ports in place. Install the I/O shield that came with your motherboard before installing the motherboard.

1. Power down the system and remove the power cord from the rear of the power supply. Remove the cords from both power supplies if your chassis includes a redundant power module. Remove the chassis cover as described in Section 5-2.
2. Locate the I/O shield that came with the motherboard.
3. Push the I/O shield gently into the rear opening of the chassis, until it clicks into the secure position.

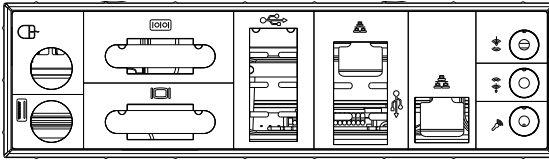

Figure 5-8. Motherboard I/O Shield (Example)

5-5 Installing the Motherboard

Permanent and Optional Standoffs

Standoffs prevent short circuits by creating space between the motherboard and the chassis floor. The SC842 chassis includes permanent and optional removable standoffs in locations used by most motherboards. These standoffs accept the rounded Phillips head screws included in the SC842 accessories packaging.

Some motherboards require additional screws for heatsinks, general components and/or to secure them to the chassis. Optional standoffs are included to support these motherboards. To use an optional standoff, you must secure a hexagonal post by screwing it into the necessary spot. Compare the mounting holes between the motherboard and the chassis, then add or remove the optional standoffs as needed.

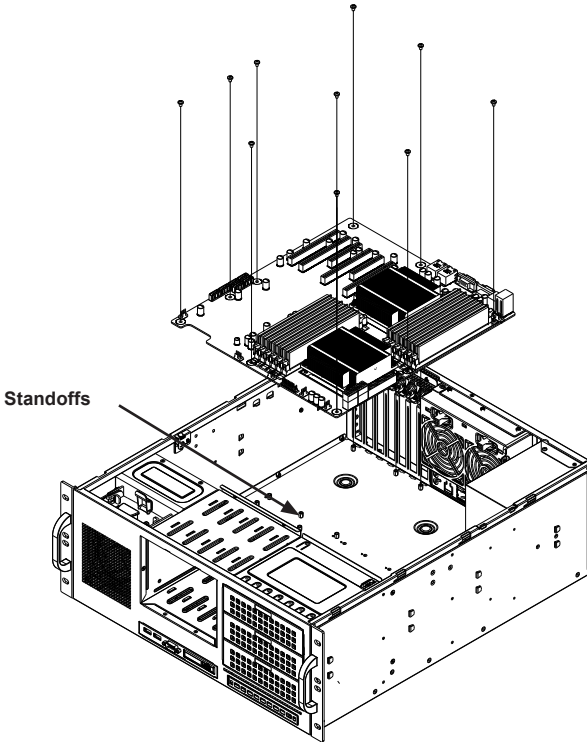

Figure 5-9. Motherboard Standoffs

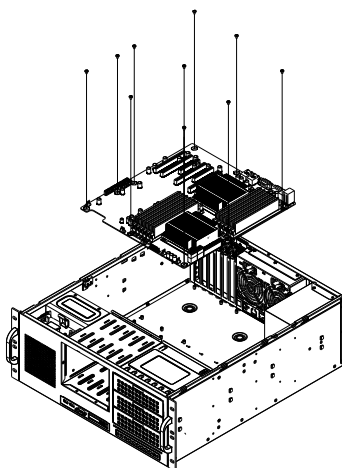

Figure 5-10. Installing the Motherboard

Motherboard Installation

Installing the Motherboard

1. Review the documentation that came with your motherboard. Become familiar with component placement, requirements, and precautions.
2. Confirm that the power supply (and redundant power supply if applicable) has been disconnected. Lay the chassis on a flat surface.
3. Open the chassis cover.
4. Remove any packaging from the chassis.
5. If required by your motherboard, install standoffs in any areas that do not have a permanent standoff. To do this, tighten a hexagonal optional standoff into the chassis.
6. Lay the motherboard on the chassis aligning the permanent and optional standoffs.
7. Secure the motherboard to the chassis using the rounded, Phillips head screws. Do not exceed eight pounds of torque when tightening down the motherboard.
8. Secure the CPU(s) and heatsinks to the motherboard.

Expansion Card Setup

The SC842TQ/i chassis features seven PCI slots which support up to seven expansion cards. SC842XTQ chassis features eleven PCI slots which support up to eleven expansion cards.

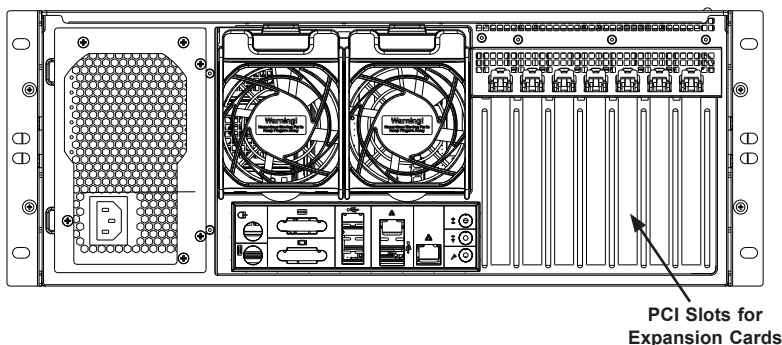

Figure 5-11. PCI Slots

Installing Expansion Cards

1. Power down the system and remove the power cord from the rear of the power supply. Remove the cords from both power supplies if your chassis includes a redundant power module. Remove the chassis cover as described in Section 5-2.
2. Locate the motherboard port which is aligned with the PCI slot where you want to install an expansion card.
3. Each PCI slot cover is secured by one screw located on the top of the cover. Remove this screw and slide the slot cover up and out of the slot. Set the screw aside for use in Step 5.
4. Gently slide the expansion card into the correct motherboard slot and lock it. Never force a component into a motherboard or the chassis.
5. Secure the expansion card with the screw set aside in Step 3.
6. Reconnect the power cord(s) to the power supply (and the redundant power supply if applicable to your chassis model), and power up the system.

Rear System Fans

The SC842 chassis includes up to two rear exhaust fans.

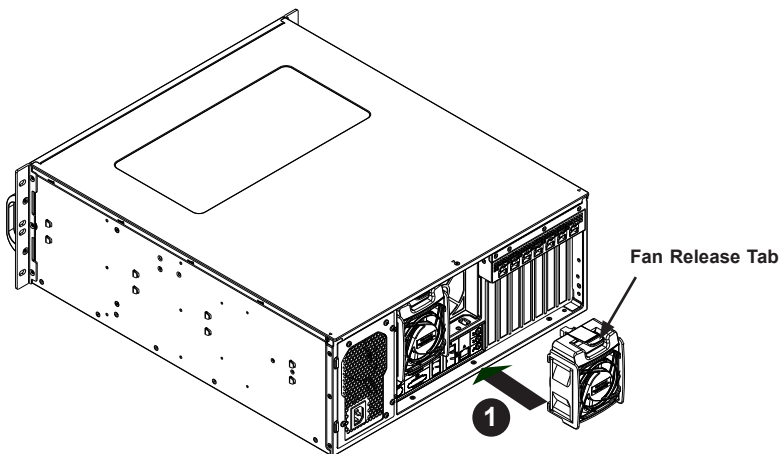

Figure 5-12. Installing the Rear Fan

Installing the Rear System Fans

Installing the Rear System Fans

1. Slide the rear fan into the slot as illustrated. The fan release tab is located just above the edge of the fan housing.
2. Ensure that the fan is secured in the fan cage and that the fan cable is connected to the motherboard.

Checking the Server's Airflow

Checking the Airflow

1. Make sure there are no objects to obstruct the airflow in and out of the server.
If necessary, route and organize the cables appropriately.
2. Do not operate the chassis without drive carriers in the drive bays.

5-6 Power Supply

The SC842 chassis includes either a 500, R600, 665 or 865 Watt power supply. In the unlikely event of a power supply failure the system must be powered-down and the power supply removed using a Phillips head screw driver.

Replacing the Power Supply

Replacing the Power Supply

1. Power down the system and remove the power cord from the rear of the power supply. Remove the cords from both power supplies if your chassis includes a redundant power module. Remove the chassis cover as described in Section 5-2.
2. Unscrew the three screws securing the power supply to the chassis. Set these screws aside for later use.
3. Pull the power supply up and out of the chassis.
4. Replace the failed power supply module with a new module of the same type or a compatible power supply module.
5. Slide the power supply into place and secure it to the chassis using the three screws which were previously set aside.
6. Reconnect the power cord(s) to the power supply (and the redundant power supply if applicable to your chassis model), and power up the system.

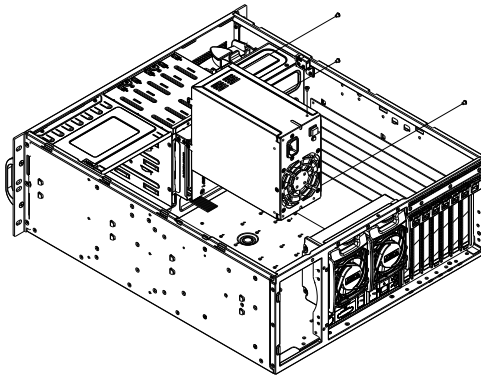

Figure 5-13. Installing the Power Supply

Installing the DVD-ROM and Peripheral Drive

SC842 chassis models supports a slim DVD-ROM and up to three 5-1/4" peripheral drives.

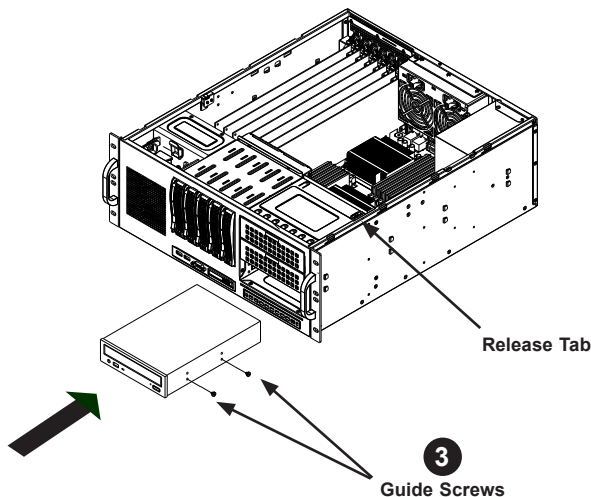

Figure 5-14. Installing the Peripheral Drive

Installing a Peripheral Drive

1. Power down the system and remove the power cord from the rear of the power supply. Remove the cords from both power supplies if your chassis includes a redundant power module. Remove the chassis cover as described in Section 5-2.
2. **If adding a drive to the chassis**, remove the mini-bezel from the drive bay. The mini-bezel is the small grating that covers the drive bay. Remove this by simply pulling it out of the bay.
If replacing an existing drive, remove the existing drive by depressing the release tab, then pulling the drive out of the chassis.
3. Attach the two guide screws which are included in the accessory box.
4. Insert the new drive unit in the slot until the release tab locks into place.
5. Connect the data and power cables to the motherboard.
6. Reconnect the power cord(s) to the power supply (and the redundant power supply if applicable to your chassis model), and power up the system.

Chapter 6

Rack Installation

6-1 Overview

This chapter provides a quick setup to install the chassis into a rack. Following these steps in the order given should enable you to complete the rack installation within a minimal amount of time.

6-2 Unpacking the System

Inspect the box the chassis was shipped in and note if it was damaged in any way. If the chassis itself shows damage you should file a damage claim with the carrier who delivered it.

Decide on a suitable location for the rack unit that will hold the chassis. It should be situated in a clean, dust-free area that is well ventilated. Avoid areas where heat, electrical noise and electromagnetic fields are generated. You will also need it placed near a grounded power outlet. Be sure to read the Rack and Server Precautions in the next section.

6-3 Preparing for Setup

Rail assemblies (two inner rails, two outer rails and the mounting screws you will need to install the system into a four-post rack) are optional features on the SC842 chassis and can be purchased separately. Refer to the Supermicro web site at www.supermicro.com for the rail model number and ordering information. Please read this section in its entirety before beginning the installation procedure outlined in the sections that follow.

Choosing a Setup Location

- Leave enough clearance in front of the rack to enable you to open the front door completely (twenty-five inches).
- Leave approximately thirty inches of clearance in the back of the rack to allow for sufficient airflow and ease in servicing.

- This product is for installation only in a Restricted Access Location (dedicated equipment rooms, service closets and similar environments).

Rack Precautions

- Ensure that the leveling jacks on the bottom of the rack are fully extended to the floor with the full weight of the rack resting on them.
- In single rack installation, stabilizers should be attached to the rack.
- In multiple rack installations, the racks should be coupled together.
- Always make sure the rack is stable before extending a component from the rack.
- You should extend only one component at a time - extending two or more simultaneously may cause the rack to become unstable.

General Server Precautions

- Review the electrical and general safety precautions that came with the components you are adding to your chassis.
- Determine the placement of each component in the rack *before* you install the rails.
- Install the heaviest server components on the bottom of the rack first, and then work up.
- Use a regulating uninterruptible power supply (UPS) to protect the server from power surges, voltage spikes and to keep your system operating in case of a power failure.
- Allow the hot plug hard drives and power supply modules to cool before touching them.
- Always keep the rack's front door and all panels and components on the servers closed when not servicing to maintain proper cooling.

Rack Mounting Considerations

Ambient Operating Temperature

If installed in a closed or multi-unit rack assembly, the ambient operating temperature of the rack environment may be greater than the ambient room temperature. Therefore, consideration should be given to installing the equipment in an environment compatible with the manufacturer's maximum rated ambient temperature (T_{mra}).

Reduced Airflow

Equipment should be mounted into a rack so that the amount of airflow required for safe operation is not compromised.

Mechanical Loading

Equipment should be mounted into a rack so that a hazardous condition does not arise due to uneven mechanical loading.

Circuit Overloading

Consideration should be given to the connection of the equipment to the power supply circuitry and the effect that any possible overloading of circuits might have on overcurrent protection and power supply wiring. Appropriate consideration of equipment nameplate ratings should be used when addressing this concern.

Reliable Ground

A reliable ground must be maintained at all times. To ensure this, the rack itself should be grounded. Particular attention should be given to power supply connections other than the direct connections to the branch circuit (i.e. the use of power strips, etc.).



To prevent bodily injury when mounting or servicing this unit in a rack, you must take special precautions to ensure that the system remains stable. The following guidelines are provided to ensure your safety:

- This unit should be mounted at the bottom of the rack if it is the only unit in the rack.
- When mounting this unit in a partially filled rack, load the rack from the bottom to the top with the heaviest component at the bottom of the rack.
- If the rack is provided with stabilizing devices, install the stabilizers before mounting or servicing the unit in the rack.

6-4 Rack Mounting

Rack Mounting Overview

This section provides information on installing the SC842 chassis into an open rack. There are a variety of rack units on the market, which may mean the assembly procedure will differ slightly. You should also refer to the installation instructions that came with the rack unit you are using.

Mounting the Chassis in an Open (Telco) Style Rack

To install the chassis into a Telco type rack, use one L-shaped bracket on either side of the chassis (two total). First, determine how far from the front of the rack the server will extend. Larger chassis should be positioned to balance the weight between front and back. If a bezel is included on your chassis, remove it, then attach the two front brackets to each side of the chassis. Finish by sliding the chassis into the rack and tightening the brackets to the rack. Additional L-brackets may be purchased separately if additional support is required.

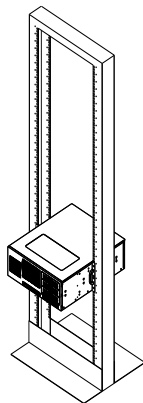

Figure 6-1. Mounting in an Open Style Rack

Warning: When initially installing the server to a rack, test that the rail locking tabs engage to prevent the server from being overextended. Have a rack lift in place as a precaution in case the test fails.

Note: figures are for illustrative purposes only. Always install servers into racks from the bottom up.



Stability hazard. The rack stabilizing mechanism must be in place, or the rack must be bolted to the floor before you slide the unit out for servicing. Failure to stabilize the rack can cause the rack to tip over.

6-5 Rack Mounting with the Optional Rail System

Rail System Overview

This section provides information on installing the SC842 chassis into a four-post rack unit with the optional quick-release rails. There are a variety of rack units on the market, which may mean the assembly procedure will differ slightly. You should also refer to the installation instructions that came with the rack unit you are using.

Separating the Sections of the Rack Rails

The optional rail package includes two rail assemblies in the rack mounting kit. Each assembly consists of two sections: an inner fixed chassis rail that secures directly to the server chassis and an outer fixed rack rail that secures directly to the rack itself.

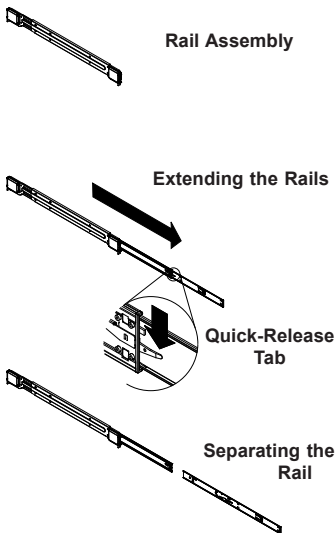

Separating the Inner and Outer Rails

1. Locate the rail assembly in the chassis packaging.
2. Extend the rail assembly by pulling it outward.
3. Press the quick-release tab.
4. Separate the inner rail from the outer rail assembly.

Figure 6-2. Separating the Rack Rails

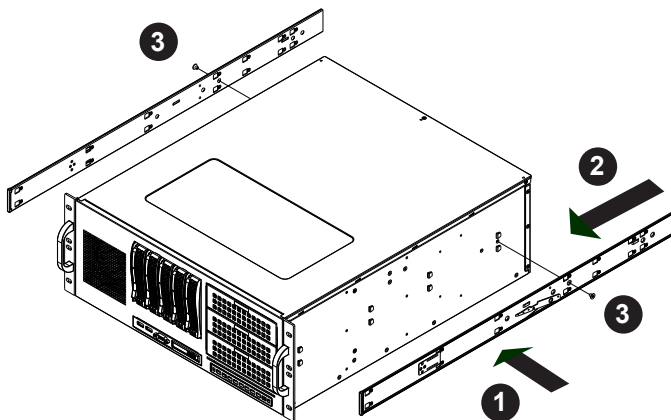

Figure 6-3. Installing the Inner Rails

Installing the Inner Rails

Installing the Inner Rails

1. Place the inner rails on the side of the chassis aligning the hooks of the chassis with the rail holes. Make sure the rail faces "outward".
2. Slide the inner rail toward the front of the chassis.
3. Secure the chassis with two screws as illustrated. Repeat steps 1 and 2 for the other inner rail.



Warning: do not pick up the server by the front handles. They are designed to pull the system from a rack only.

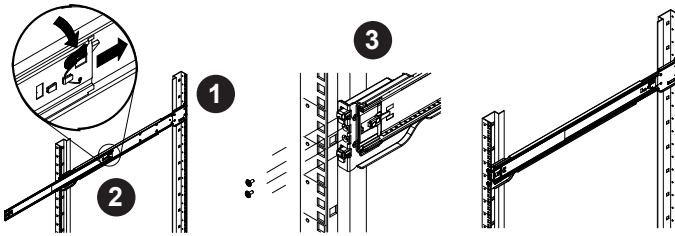

Figure 6-4. Assembling the Outer Rails

Outer Rack Rails

Outer rails attach to the rack and hold the chassis in place.

Installing the Outer Rails to the Rack

1. Secure the back end of the outer rail to the rack, using the screws provided.
2. Press the button where the two outer rails are joined to retract the smaller outer rail.
3. Hang the hooks of the rails onto the rack holes and if desired, use screws to secure the front of the outer rail onto the rack.
4. Repeat steps 1-3 for the remaining outer rail.

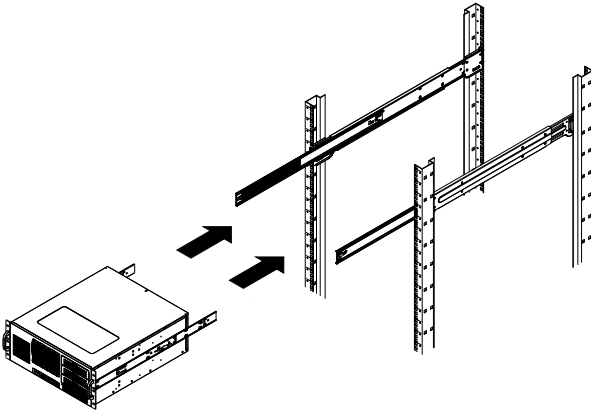

Figure 6-5. Installing the Chassis into a Rack

Note: figures are for illustrative purposes only. Always install servers into racks from the bottom up.

Installing the Chassis into a Rack

1. Extend the outer rails as illustrated above.
2. Align the inner rails of the chassis with the outer rails on the rack.
3. Slide the inner rails into the outer rails, keeping the pressure even on both sides. When the chassis has been pushed completely into the rack, it should click into the locked position.
4. Optional screws may be used to secure the front of the chassis to the rack.

Appendix A

SC842 Chassis Cables

A-1 Overview

This appendix lists supported cables for your chassis system. It only includes the most commonly used components and configurations. For more compatible cables, refer to the manufacturer of the motherboard you are using and our Web site at: www.supermicro.com.

A-2 Cables List

SC842 Chassis			
Part #	Type	Length	Description
CBL-0044L	Cable	2'	SATA cable
CBL-0087	Ribbon, Round	20"	16-pin to 16-pin ribbon cable for control panel
CBL-0084L	Cable	6"	Front control cable, 16-pin split cable
CBL-0286L	Cable	30 cm	4-pin to 4-pin rear fan power extension with square header.
CBL-0336L	Cable	57 cm	4-pin middle fan power extension
Varies	Cable	6'	Regional power cord

Notes

Appendix B

SC842 Power Supply Specifications

This appendix lists power supply specifications for your chassis system.

SC842i-500B	
500W	
MFR Part #	PWS-502-PQ
Rated AC Voltage	100 - 240V 50-60Hz 7-3.5 Amp
+5V standby	3 Amp
+12V1	17 Amp
+12V2	17 Amp
+12V3	17 Amp
+12V4	18 Amp
-12V	0.5 Amp
+5V	20 Amp
+3.3V	15 Amp

SC842XTQ-R606B	
600W	
MFR Part #	PWS-606P-1R
AC Input	100 - 240V 50-60Hz 7.5 - 3.0 Amp
DC Output	3 Amp @ +5V standby 50 Amp @ +12V
With Power Distributor	+5V: 30 Amp +3.3V: 28 Amp -12V: 0.6 Amp

SC842TQ-665B	
665W	
MFR Part #	PWS-665-PQ
Rated AC Voltage	100 - 240V 50 - 60Hz 10 -5 Amp
+5V standby	6 Amp
+12V	54 Amp
+5V	30 Amp
+3.3V	24 Amp
-12V	0.5 Amp

SC842TQ-865B	
865W	
MFR Part #	PWS-865-PQ
Rated AC Voltage	100 - 240V 50 - 60Hz 12 - 6 Amp
+5V standby	6.5 Amp
+12V	70 Amp
+5V	30 Amp
+3.3V	30 Amp
-12V	1 Amp

Appendix C

BPN-BPN-SAS-842TQ Backplane Specifications

To avoid personal injury and property damage, carefully follow all the safety steps listed below when accessing your system or handling the components.

C-1 ESD Safety Guidelines

Electrostatic Discharge (ESD) can damage electronic components. To prevent damage to your system, it is important to handle it very carefully. The following measures are generally sufficient to protect your equipment from ESD.

- Use a grounded wrist strap designed to prevent static discharge.
- Touch a grounded metal object before removing a component from the antistatic bag.
- Handle the backplane by its edges only; do not touch its components, peripheral chips, memory modules or gold contacts.
- When handling chips or modules, avoid touching their pins.
- Put the card and peripherals back into their antistatic bags when not in use.

C-2 General Safety Guidelines

- Always disconnect power cables before installing or removing any components from the computer, including the BPN-BPN-SAS-842TQ backplane.
- Disconnect the power cable before installing or removing any cables from the backplane.
- Make sure that the BPN-BPN-SAS-842TQ backplane is securely and properly installed on the motherboard to prevent damage to the system due to power shortage.

C-3 An Important Note to Users

All images and layouts shown in this user's guide are based upon the latest backplane revision available at the time of publishing. The card you have received may or may not look exactly the same as the graphics shown in this manual.

C-4 Introduction to the BPN-BPN-SAS-842TQ Backplane

The BPN-BPN-SAS-842TQ backplane has been designed to utilize the most up-to-date technology available, providing your system with reliable, high-quality performance.

This manual reflects BPN-BPN-SAS-842TQ Revision 1.01, the most current release available at the time of publication. Always refer to the Supermicro web site at www.supermicro.com for the latest updates, compatible parts and supported configurations.

C-5 Front Connectors

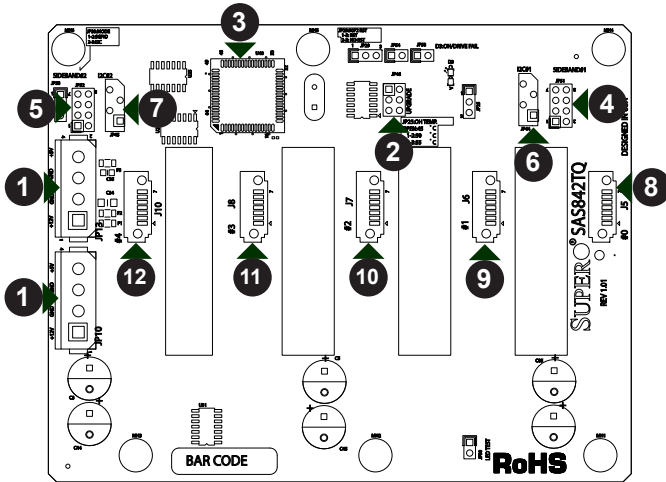

Figure C-1. Front Connectors

Front Connectors

- | | |
|---|--|
| 1. Power Connectors (4-pin): JP10, JP13 | 7. I ² C Connector #2: JP45 |
| 2. Upgrade Pin: JP46 | 8. Connector #0: J5 |
| 3. MG9072 Chip | 9. Connector #1: J6 |
| 4. Sideband #1: JP51 | 10. Connector #2: J7 |
| 5. Sideband #2: JP52 | 11. Connector #3: J8 |
| 6. I ² C Connector #1: JP44 | 12. Connector #4: J10 |

C-6 Front Connector and Pin Definitions

#1. Backplane Main Power Connectors

These 4-pin connectors designated JP10 and JP13 provide power to the backplane. See the table on the right for pin definitions.

Backplane Main Power 4-Pin Connector	
Pin#	Definition
1	+12V
2 and 3	Ground
4	+5V

#2 Upgrade Connector

The upgrade connector is designated JP46 and is for the manufacturer's diagnostic purposes only.

#3. MG9072 Chip

The MG9072 is an enclosure management chip that supports the SES-2 controller and SES-2 protocols.

#4 and #5. Sideband Connectors

The sideband connectors are designated JP51 and JP52. For SES-2 to work properly, you must connect an 8-pin sideband cable. See the table to the right for pin definitions.

Sideband Connectors			
Pin #	Definition	Pin #	Definition
2	SDIN/ Backplane Addressing (SB5)	1	Controller ID (SB6)
4	SDOUT/I ² C Reset (SB4)	3	GND (SB2)
6	GND (SB3)	5	SLOAD/ SDA (SB1)
8	Backplane ID (SB7)	7	SCLOCK/ SCL (SB0)

#6 and #7. I²C Connectors

The I²C connectors, designated JP44 and JP45, are used to monitor HDD activity and status. See the table on the right for pin definitions.

I ² C Connector Pin Definitions	
Pin#	Definition
1	Data
2	Ground
3	Clock
4	No Connection

#8 - #12. SAS/SATA Connectors

The SAS/SATA connectors are numbered 0 through 4. Each may be connected to the system with a SAS or SATA cable.

C-7 Front Jumper Locations and Pin Definitions

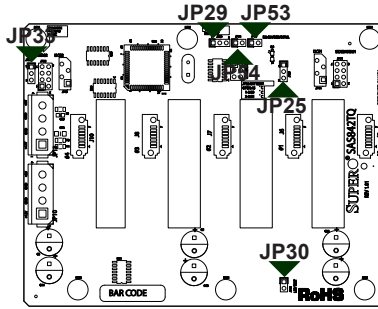
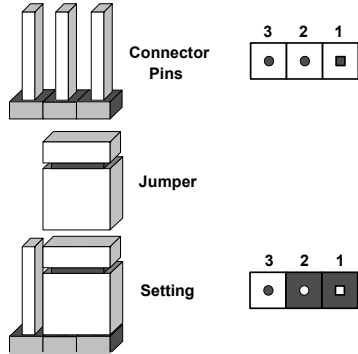

Figure C-2. Front Jumpers

Explanation of Jumpers

To modify the operation of the backplane, jumpers can be used to choose between optional settings. Jumpers create shorts between two pins to change the function of the connector. Pin 1 is identified with a square solder pad on the printed circuit board. Note: On two pin jumpers, "Closed" means the jumper is on and "Open" means the jumper is off the pins.



Jumper Settings		
Jumper	Jumper Settings	Note
JP25	Open: 45 degrees Celcius Pins 1-2: 50 degrees Celcius Pins 2-3: 55 degrees Celcius	OH TEMP: Overheat temperature settings
JP29	Pins 1-2: Reset Pins 2-3: No reset	MG9072 chip reset
JP30	---	For manufacturer's use only
JP53	---	For manufacturer's use only
JP54	---	For manufacturer's use only

I²C and SGPIO Mode Jumper Settings

This backplane can utilize I²C or SGPIO. SGPIO is the default mode and can be used without making changes to your jumpers. The following information details which jumpers must be configured to use I²C mode or restore your backplane to SGPIO mode.

I ² C and SGPIO Settings		
Jumper	SGPIO Jumper Setting (Default)	I ² C Jumper Setting
JP33	Pins 1-2	Pins 2-3

Front LED Indicators

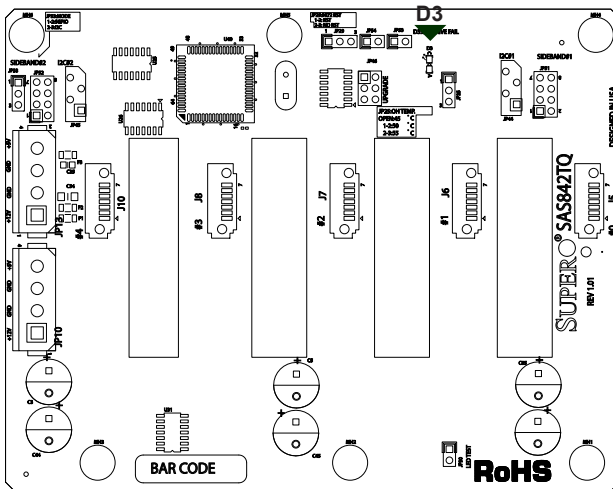

Figure C-3. Front LEDs

Front LEDs		
LED	State	Specification
D3	On	Overheat or Drive Failure

C-8 Rear Connectors and LED Indicators

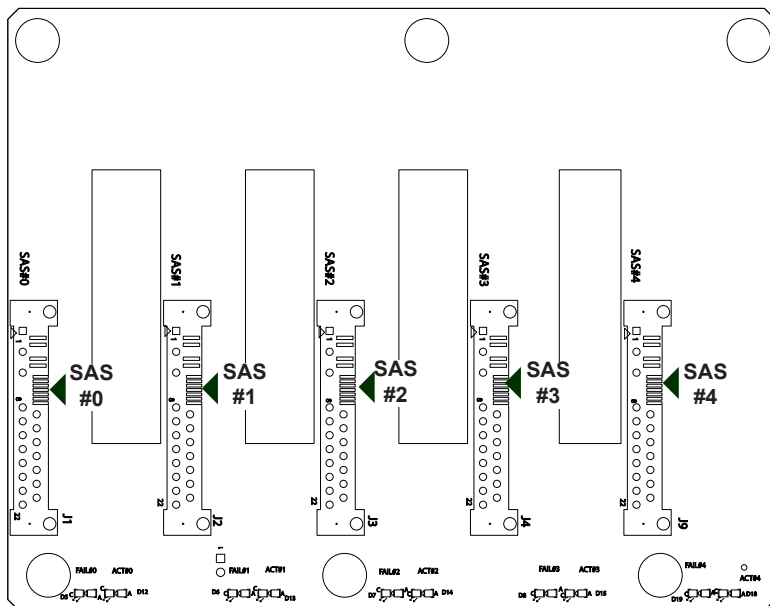

Figure C-4. Rear Connectors

Rear SAS/SATA Connectors		
Rear Connector	Connector Number	SAS/SATA Drive Number
SAS #0	J1	SAS/SATA HDD #0
SAS #1	J2	SAS/SATA HDD #1
SAS #2	J3	SAS/SATA HDD #2
SAS #3	J4	SAS/SATA HDD #3
SAS #4	J9	SAS/SATA HDD #4

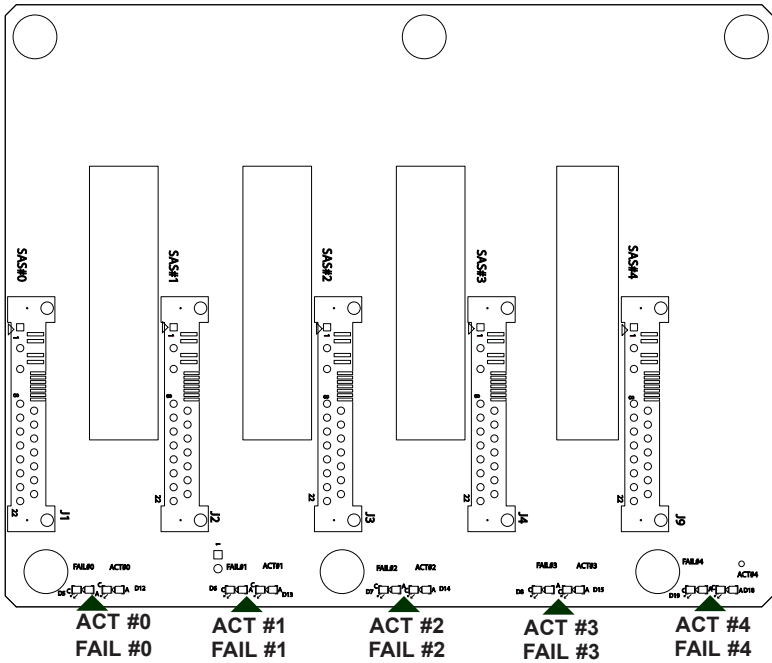

Figure C-5. Rear LEDs

Rear LED Indicators		
Rear Connector	Hard Drive Activity	Failure LED
SAS #0	D12	D5
SAS #1	D13	D6
SAS #2	D14	D7
SAS #3	D15	D8
SAS #4	D18	D19

Disclaimer (cont.)

The products sold by Supermicro are not intended for and will not be used in life support systems, medical equipment, nuclear facilities or systems, aircraft, aircraft devices, aircraft/emergency communication devices or other critical systems whose failure to perform be reasonably expected to result in significant injury or loss of life or catastrophic property damage. Accordingly, Supermicro disclaims any and all liability, and should buyer use or sell such products for use in such ultra-hazardous applications, it does so entirely at its own risk. Furthermore, buyer agrees to fully indemnify, defend and hold Supermicro harmless for and against any and all claims, demands, actions, litigation, and proceedings of any kind arising out of or related to such ultra-hazardous use or sale.