

DISCLAIMER

Crimson AV LLC, intend to make this manual accurate and complete. However, Crimson AV LLC makes no claim that the information contained herein covers all details, conditions or variations, nor does it provide for every possible contingency in connection with the installation or use of this product. The information contained in this document is subject to change without notice or obligation of any kind. Crimson AV LLC makes no representation of warranty, expressed or implied, regarding the information contained herein. Crimson AV LLC assumes no responsibility for accuracy, completeness or sufficiency of the information contained in this document.



WARNING!



WARNING! SEVERE PERSONAL INJURY AND PROPERTY DAMAGE CAN RESULT FROM IMPROPER INSTALLATION OR ASSEMBLY. READ THE FOLLOWING WARNINGS BEFORE BEGINNING.

WARNING! FAILURE TO READ, THOROUGHLY UNDERSTAND, AND FOLLOW ALL INSTRUCTIONS CAN RESULT IN SERIOUS PERSONAL INJURY, DAMAGE TO EQUIPMENT, OR VOIDING OF FACTORY WARRANTY! IT IS THE INSTALLER'S RESPONSIBILITY TO MAKE SURE ALL COMPONENTS ARE PROPERLY ASSEMBLED AND INSTALLED USING THE INSTRUCTIONS PROVIDED.

WARNING! EXCEEDING THE WEIGHT CAPACITY CAN RESULT IN SERIOUS PERSONAL INJURY OR DAMAGE TO EQUIPMENT! IT IS THE INSTALLER'S RESPONSIBILITY TO MAKE SURE THE COMBINED WEIGHT OF ALL COMPONENTS ATTACHED TO THE M90 UP TO (AND INCLUDING) THE DISPLAY DOES NOT EXCEED 300 LBS (136 KG). USE WITH HEAVIER TELEVISIONS MAY RESULT IN INSTABILITY CAUSING TIP OVER RESULTING IN DEATH OR SERIOUS INJURY!

WARNING! USE THIS MOUNTING SYSTEM ONLY FOR ITS INTENDED USE AS DESCRIBED IN THESE INSTRUCTIONS. DO NOT USE ATTACHMENTS NOT RECOMMENDED BY THE MANUFACTURER.

WARNING! NEVER OPERATE THIS MOUNTING SYSTEM IF IT IS DAMAGED. RETURN THE MOUNTING SYSTEM TO A SERVICE CENTER FOR EXAMINATION AND REPAIR.
WARNING! DO NOT USE THIS PRODUCT OUTDOORS.

WARNING! RISK OF INJURY TO PERSONS! DO NOT PLACE VIDEO EQUIPMENT SUCH AS TELEVISIONS OR COMPUTER MONITORS ON CART LEGS.

WARNING! RISK OF SERIOUS INJURY OR DEATH! PLACING A REMOTE CONTROL OR TOY ON THE CART MAY ENCOURAGE A CHILD TO CLIMB ONTO THE CART CAUSING THE CART TO TIP OVER ONTO THE CHILD. DO NOT PLACE REMOTE CONTROLS OR TOYS ON THE CART!

WARNING! RISK OF SERIOUS INJURY OR DEATH! RELOCATING AUDIO AND/OR VIDEO EQUIPMENT TO THE CART MAY RESULT IN THE CART COLLAPSING OR OVERTURNING ONTO A CHILD. DO NOT RELOCATE AUDIO AND/OR VIDEO EQUIPMENT TO THE CART!

NOTE: THE M90 CART HAS NO USER SERVICEABLE PARTS. NOTE: THE M90 CART CAN SUPPORT SCREEN SIZES UP TO A MAXIMUM OF 100" WIDE.

WEIGHT CAPACITY

EN Maximum Weight Capacity

ES Peso máximo de pantalla

FR Poids maximal de l'écran

300lb/136kg



EN

PACKAGE CONTENTS

ES Contenido del paquete

FR Contenu de l'emballage

MS90 UPRIGHTS

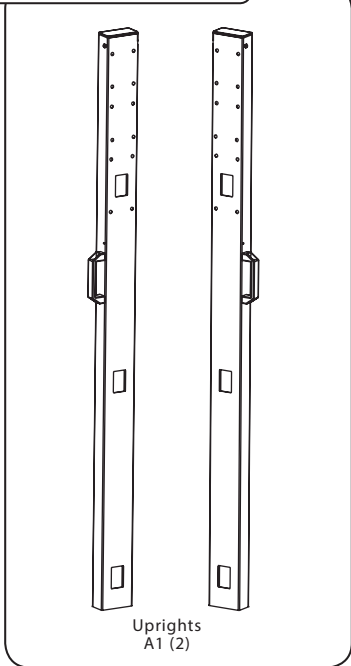

M90 BASE

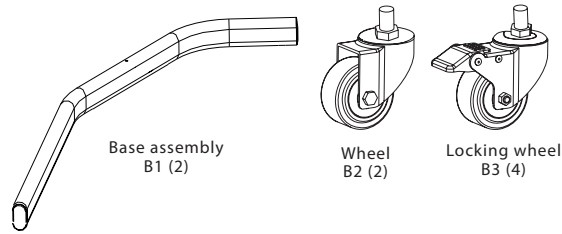

S3731-1

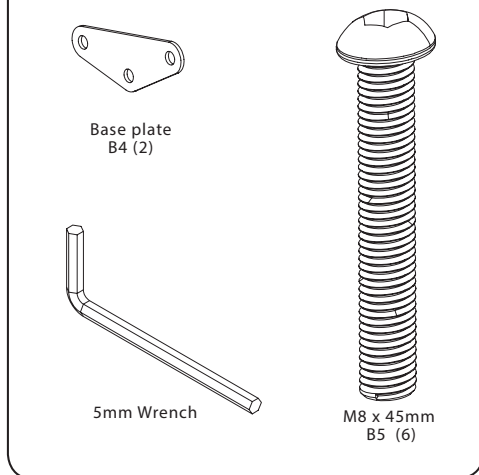

EN

PACKAGE CONTENTS

ES Contenido del paquete

FR Contenu de l'emballage

MS100 ADAPTER

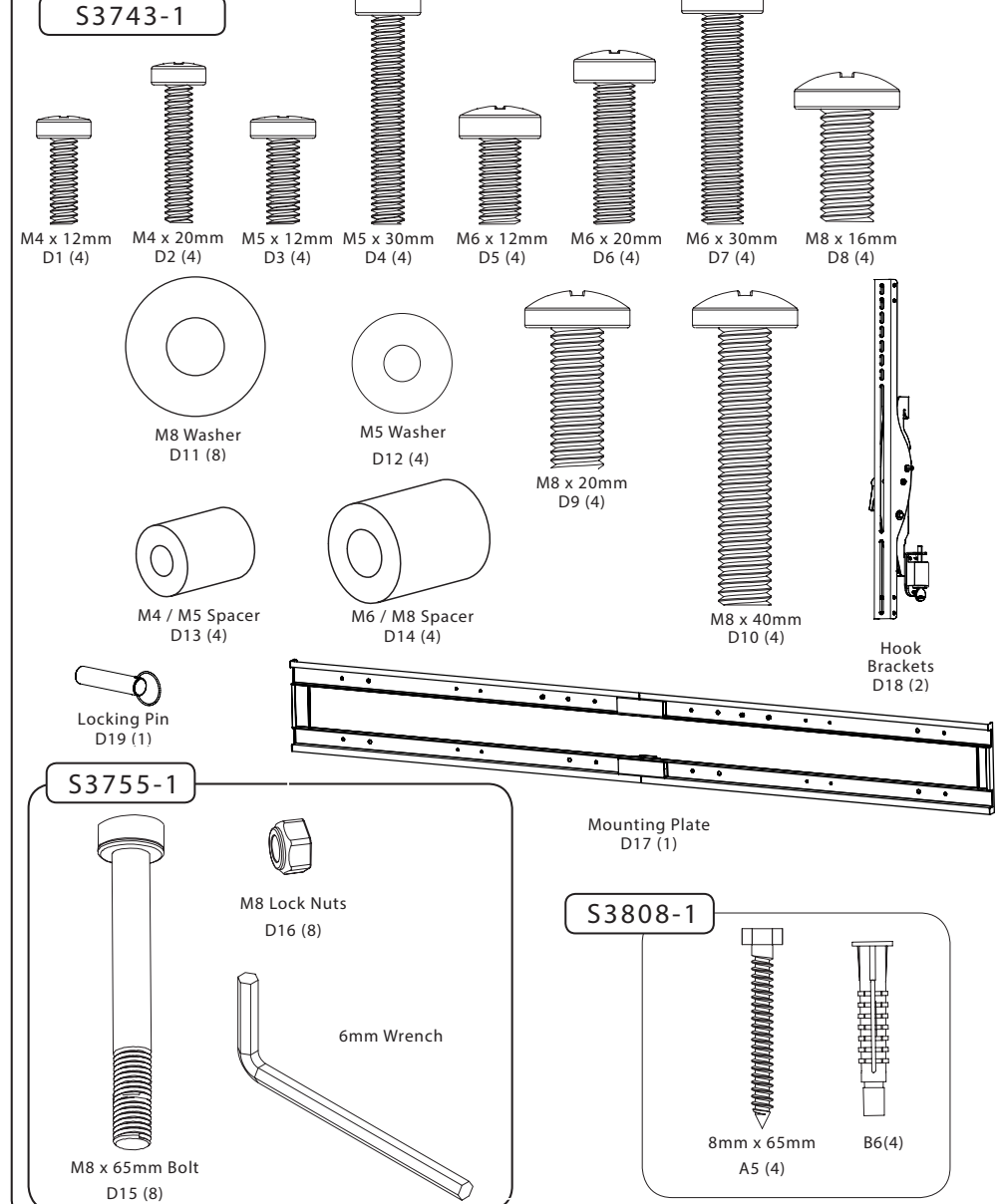

EN

PACKAGE CONTENTS

ES

Contenido del paquete

FR

Contenu de l'emballage

MS90 BOX

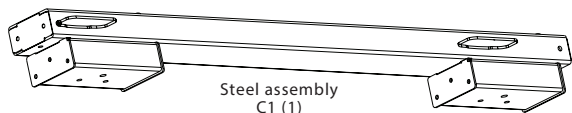

S3876-1

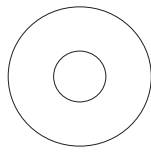
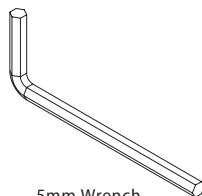
M6 Washer
C2 (8)

5mm Wrench

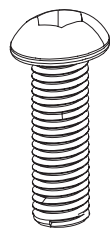
M8 x 15mm
C3 (8)M6 x 30mm
C4 (8)**EN**

ACCESSORIES SOLD SEPARATELY

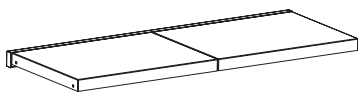
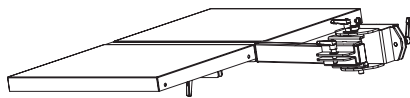
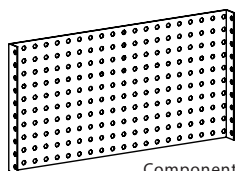
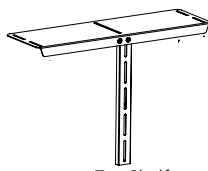
Back Shelf
MS9BSlide Shelf
MS9SComponent Panel
MPC9Top Shelf
MS9T

INSTALLATION INSTRUCTIONS

ES

Instrucciones de instalación

FR

Instructions d'installation

1 ATTACH WHEELS TO CART BASE ASSEMBLY

EN

Thread wheels (B2 & B3) into base assembly (B1). Place the locking wheels (B3) in the rear and front.

ES

Ruedas de hilo (B2 y B3) en la base de montaje (B1). Coloque el bloqueo de las ruedas (B3) en la parte trasera y en el frente.

FR

Fixez les roulettes (B2 et B3) pour l'assemblage de base (B1). Placez le blocage des roues (B3) à l'arrière et avant.

1

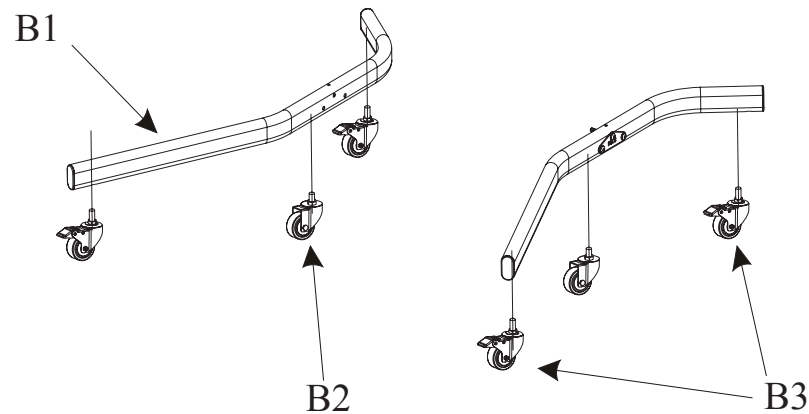

2-1

ATTACH CART BASE ASSEMBLY

- EN** Using base plates (B4) and bolts (B5) attach cart base assembly to steel assembly.
- ES** Utilizando las placas base (B4) y tornillos (B5) colocar la base de montaje a la extrusión.
- FR** En utilisant les plaques de base (B4) et boulons (B5) attacher la base de montage à l'extrusion.

2-1

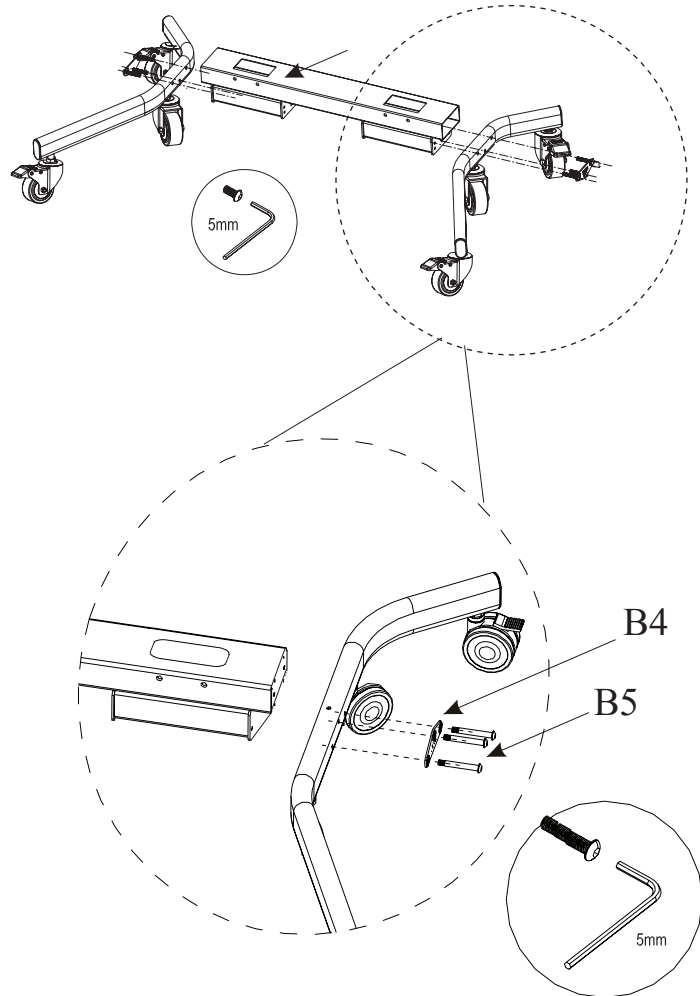

2-2

INSTALL CART UPRIGHTS

- EN** Slide uprights (A1) into steel assembly (C1) and secure using bolts (C3 and C4).
- ES** Extrusiones (A1) de diapositivas en el conjunto de caja de acero (C1) y seguro pernos con (C3 y C4).
- FR** Extrusions (A1) Slide dans l'assemblage de la boîte en acier (C1) et fixer avec des vis (C3 et C4).

2-2

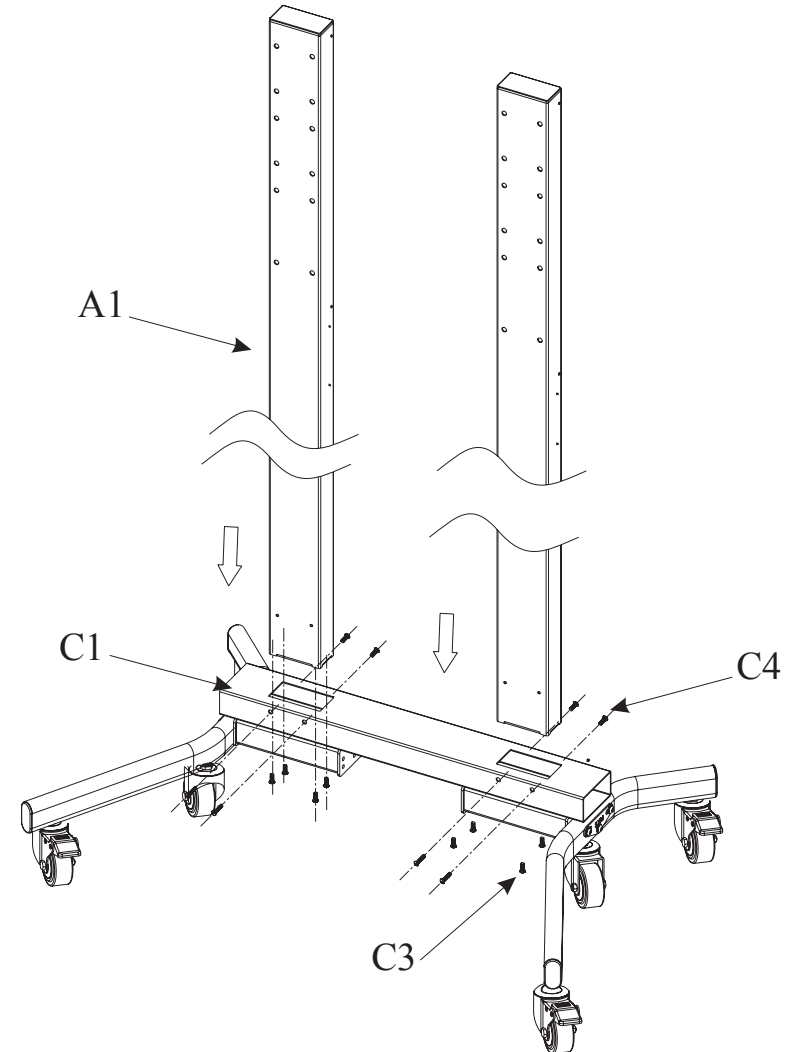

3 ATTACH CART/STAND UNIVERSAL PLATE

EN Attach universal plate (D17) to desired position on uprights with bolt (D15) and nut (D16).

ES Fije la placa universales (D17) a la posición deseada en montantes con el perno (D15) y la tuerca (D16).

FR Fixez la plaque universelle (D17) à la position désirée sur des montants avec un boulon (D15) et l'écrou (D16).

3

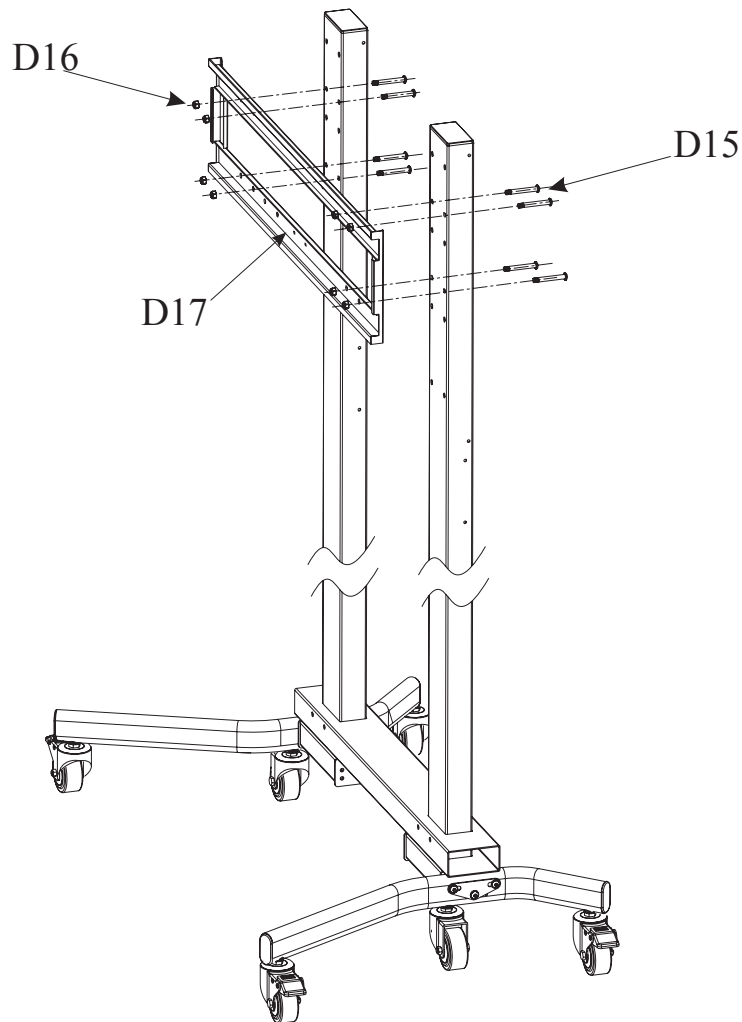

4-1 ATTACH MOUNT BRACKETS

EN Align mount bracket (D18) to holes on back of TV. Fasten using supplied hardware with a screwdriver. Hand tools only.

ES Alinee el soporte de montaje (D18) a los agujeros en la parte posterior de la televisión. Sujete con partes que vienen con un destornillador. Herramientas de mano solamente.

FR Aligner le support de montage (D18) dans les trous à l'arrière du téléviseur. Fixer à l'aide de matériel fourni avec un tournevis. Outils à main seulement..

4-1

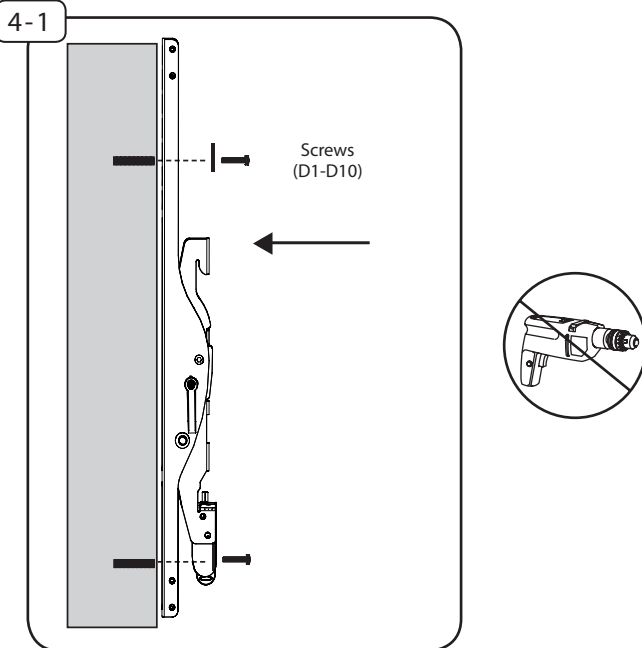

WARNING!



EXCEEDING THE WEIGHT CAPACITY CAN RESULT IN SERIOUS PERSONAL INJURY OR DAMAGE TO EQUIPMENT! IT IS THE INSTALLER'S RESPONSIBILITY TO MAKE SURE THE COMBINED WEIGHT OF ALL COMPONENTS ATTACHED TO THE M90 UP TO (AND INCLUDING) THE DISPLAY DOES NOT EXCEED 300 LBS (136 KG). USE WITH HEAVIER TELEVISIONS MAY RESULT IN INSTABILITY CAUSING TIP OVER RESULTING IN DEATH OR SERIOUS INJURY!

4-2

ATTACH MOUNT BRACKETS

EN If screws bottom out use washers (not included) to eliminate slack.

ES Si los tornillos tocó fondo a continuación, utilizar arandelas (no incluidos) para eliminar la holgura.

FR Si les vis touché le fond, puis utiliser des rondelles (non inclus) afin d'éliminer mou.

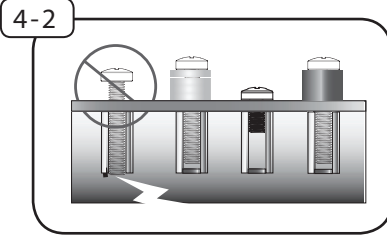

4-3

ATTACH MOUNT BRACKETS

EN Use spacers (D13 or D14) between TV and mount if needed.

ES Utilice espaciadores (D13 y D14) entre la televisión y montar si es necesario.

FR Utiliser des entretoises (D13 et D14) entre le téléviseur et le support métallique si

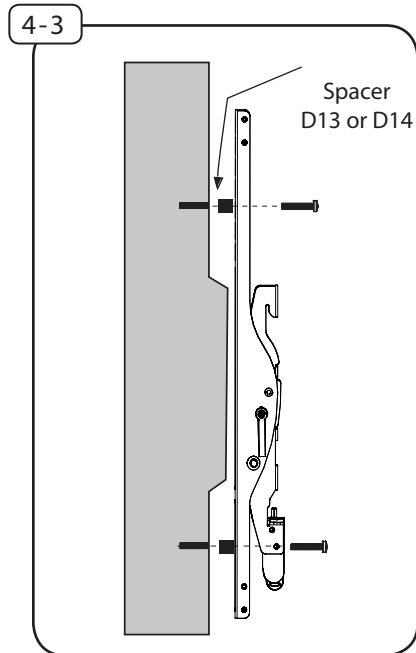

5

HANG TV

EN Hang TVs by hooking mount bracket onto adapter plate and lock in place with key.

ES Colgar televisores adaptadora soporte de montaje y el bloqueo en su lugar con la tecla.

FR Accrochez sur de montage sur plaque d'adaptation et de verrouillage en place avec la clé.

5

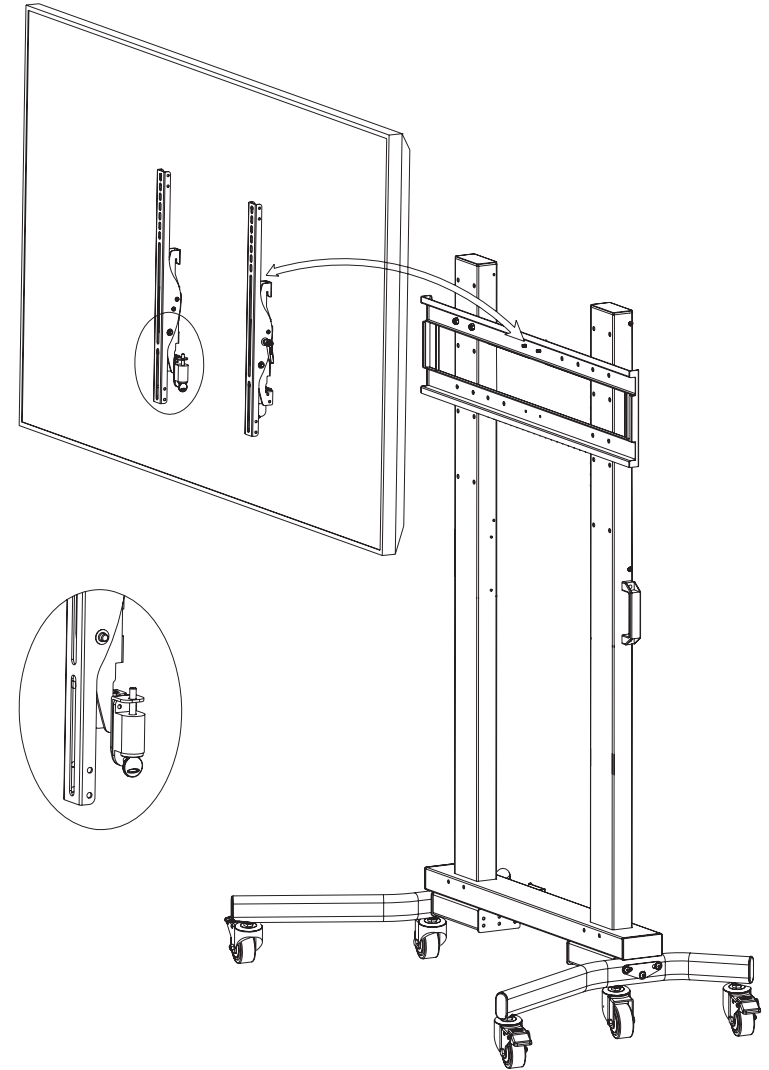

6

ADJUST TILT

EN Adjust tilt to desired position and turn tilt knob clockwise to tighten and secure.

ES Ajuste la inclinación a la posición deseada y gire la inclinación hacia la derecha para apretar y seguro.

FR Régler l'inclinaison à la position désirée et tourner inclinaison vers la droite pour serrer et sécurisé.

WARRANTY

Congratulations on the purchase of this Crimson product! The product you now have in your possession is made of durable materials and is based on a design, every detail of which has been meticulously thought-out. That is why Crimson AV LLC products are covered by a 10-year warranty against defects in materials or manufacturing.

Crimson AV LLC disclaims any liability for modifications, improper installations, or installations over the specified weight range. To the maximum extent permitted by law, Crimson AV LLC disclaims any other warranties, expressed or implied, including warranties of fitness for a particular purpose and warranties of merchantability. Crimson AV LLC will not be liable for any damages arising out of the use of, or inability to use, Crimson AV LLC products. Crimson AV LLC bears no responsibility for incidental or consequential damages. This includes, but is not limited to, any labor charges for the repair of Crimson AV LLC products performed by anyone other than Crimson AV LLC.

Specifications are subject to change without prior notice.

6

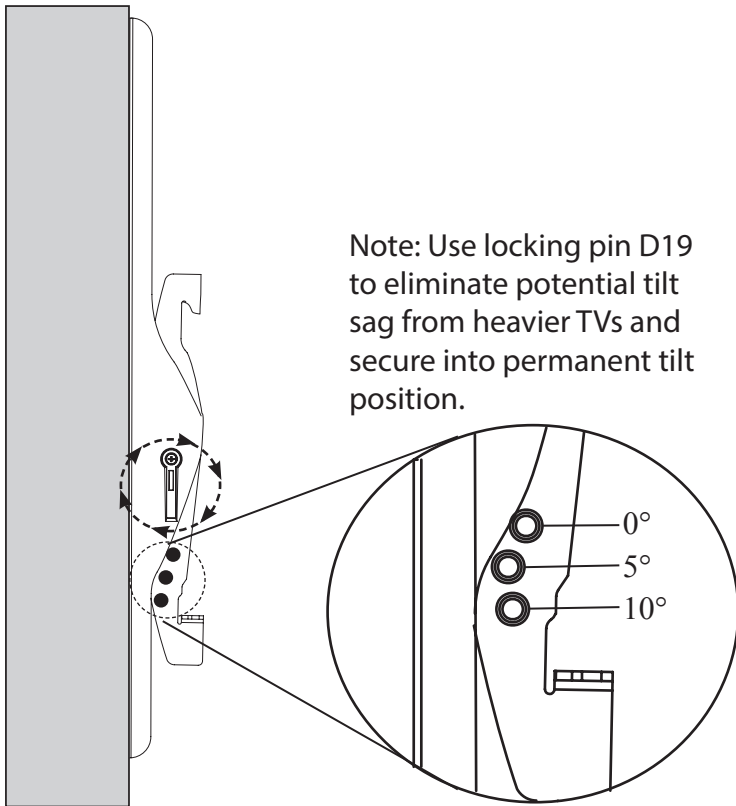

ES

GARANTÍA

ES

¡Felicitaciones por su compra de este producto Crimson! Ahora tiene en su poder un producto fabricado con materiales resistentes, basado en un diseño muy bien meditado. Por ello, Crimson AV LLC responde de los posibles defectos de material o fabricación con una garantía de 10 años.

Crimson AV LLC no se hace responsable de modificaciones, instalaciones inadecuadas o instalaciones que superen el rango de peso especificado. En la medida en que la ley lo permita, Crimson AV LLC no se hace responsable de ninguna otra garantía, expresa o implícita, incluso las garantías de aptitud para un fin determinado o de comercialización.

Crimson AV LLC no se hace responsable de ningún tipo de daños causados por el uso de los productos Crimson AV LLC o por el uso inapropiado de dichos productos. Crimson AV LLC no es responsable de los daños incidentales o emergentes. Dentro de éstos se incluyen todo tipo de gastos que pudieran surgir de las reparaciones de productos Crimson AV LLC que no se hayan realizado en Crimson AV LLC.

Las especificaciones están sujetas a cambios sin previo aviso.

FR

GARANTIE

FR

Nous vous félicitons pour l'achat de ce produit Crimson! Vous venez d'acquérir un produit réalisé à partir de matériaux durables et d'une conception ingénieuse jusque dans les moindres détails. Crimson AV LLC est ainsi en mesure de garantir ses produits pendant 10 ans contre les défauts de matériaux et de fabrication.

Crimson AV LLC rejette toute responsabilité relativement à quelque problème pouvant être associé à une modification d'un produit, à une mauvaise installation ou à une installation ne respectant pas les limites de charge. Sous réserve des lois en vigueur, Crimson AV LLC réfute toute autre garantie expresse ou implicite, notamment toute garantie de commercialisation ou de convenance à un usage quelconque. Crimson AV LLC réfute toute responsabilité pour des dommages résultant de l'utilisation ou de l'impossibilité d'utiliser des produits Crimson AV LLC. Crimson AV LLC réfute également toute responsabilité pour quelque dommage accessoire ou indirect. Ceci s'applique notamment aux frais de main d'oeuvre pour la réparation de produits Crimson AV LLC par une personne ne travaillant pas pour Crimson AV LLC.

Les spécifications sont sujettes à changement sans préavis.

WARRANTY CONTINUED

EN

NOTICE TO CUSTOMERS OUTSIDE THE UNITED STATES: CRIMSON PRODUCT WARRANTY APPLIES ONLY TO PRODUCTS PURCHASED IN THE UNITED STATES. FOR PURCHASES OUTSIDE OF THE UNITED STATES, PLEASE CONTACT YOUR COUNTRY'S DISTRIBUTOR FOR COUNTRY SPECIFIC WARRANTY INFORMATION.

ES

AVISO PARA CLIENTES QUE SE ENCUENTREN FUERA DE LOS EE.UU.: LA GARANTÍA DEL PRODUCTO DE CRIMSON TIENE VALIDEZ SÓLO PARA LAS COMPRAS REALIZADAS EN LOS EE.UU. SI REALIZÓ LA COMPRA EN EL EXTERIOR, COMUNÍQUESE CON EL DISTRIBUIDOR DE SU PAÍS PARA OBTENER INFORMACIÓN ESPECÍFICA ACERCA DE LA GARANTÍA EN ESE PAÍS.

FR

AVIS AUX CLIENTS DE L'EXTÉRIEUR DES ÉTATS-UNIS: CETTE GARANTIE DE PRODUIT CRIMSON S'APPLIQUE UNIQUEMENT AUX PRODUITS ACHETÉS AUX ÉTATS-UNIS. SI VOTRE PRODUIT A ÉTÉ ACHETÉ À L'EXTÉRIEUR DES ÉTATS-UNIS, LE DISTRIBUTEUR DE VOTRE PAYS POURRA VOUS RENSEIGNER SUR LES DÉTAILS DE LA GARANTIE APPLICABLE.



© 2010 Crimson AV LLC. All rights reserved.
 Crimson is a Crimson AV LLC brand. Crimson and Crimson AV Mounting Solutions logos are trademarks of Crimson AV LLC.

Crimson AV LLC
 1854 Elmdale Ave
 Glenview, IL 60026