



SALAMANDER
DESIGNS

Furniture Shaped By Your Needs ®



COLLABORATION FURNITURE BUNDLES

Popular, Pre-Configured Cabinet Solutions



D2/347BM1/DV/NO



SALAMANDER
DESIGNS
Furniture Shaped By Your Needs ®



Demanding projects require a manufacturer with trusted experience and resources. Salamander crafts technology furniture that is shaped by your business and workplace needs, and our solutions provide a new level of workplace flexibility, connecting technological functionality and ergonomics with design aesthetic. Our professional grade, premium quality furniture systems, are engineered to perform, simple to install, and built to last.

Salamander's advanced, flexible furniture solutions are designed to satisfy:

- **Integrators** appreciate high level of functionality and ease of setup.
- **Architects and designers** respect stylistic autonomy, selection, and furniture solutions that provide ADA compliance.
- **Users** respond to comfort and ergonomics, which increases productivity.

ONE STEP BUNDLES

In this book you will see credenza bundle solutions that include some of the most asked-for products in the market.



See Our **full-line catalog** for customizable credenzas for a wide range of applications.

TELEPRESENCE SOLUTIONS



D2/367BM2/MM/GW

Technological convergence has arrived in today's business environments. Furniture should also be smart and agile to support the unified communications technology that drives user engagement.

FPS1XL/EL/GG



FPS1/ELT/GG

Motorized stands add functionality, flexibility, and style to collaborative workspaces.

Our credenza solutions provide high-level workplace flexibility, connecting technical functionality with design aesthetic.



D2/347BM2/OS/BG

COLLABORATION SOLUTIONS

D1/337AM1/BL/WE



Businesses today operate in fluid, dynamic environments. Salamander builds furniture that defines and shapes today's office -- and tomorrow's. We help create adaptable, collaborative, enduring furniture that is built to perform and to last.



CREDENZAS

ONE STEP
BUNDLES

These robust, large-capacity cabinet systems house all electronics, including integrated support for AV and IT systems. Freestanding and fully-integrated, credenzas are perfect for retrofit installations, allowing for quick and efficient installation without involving additional tradespeople to install electrical wiring or reinforce walls.



D2/347BM2/CH/BO

Credenza Bundles include a selection of our most popular options.

ONE STEP BUNDLES

Camera Shelf

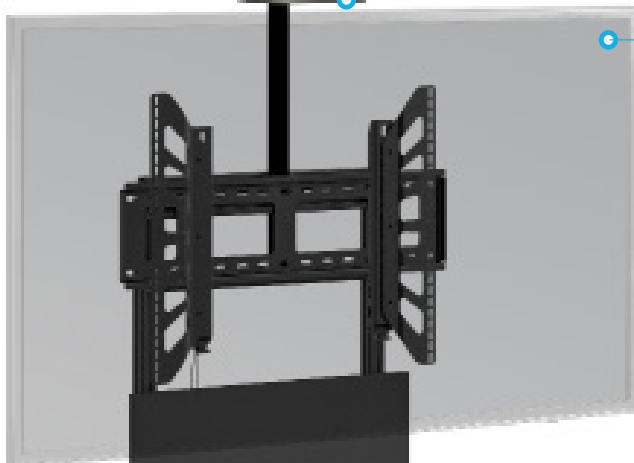

VIDEO

SINGLE OR DUAL MONITOR

Integrated mount with black modesty panel and camera shelf.

VESA Compliant:

Horizontal 200 - 850mm
Vertical 200 - 500mm

Adjustable Center of Screen settings:

61.5" / 59.75" / 58" / 56"

Aluminum Frame

Durable and flexible support chassis.

Approx. 22"D

RACK MOUNTING

13-U RACK CARTRIDGE

Pull-out 19" standard rack with rails front and back of the rack. It slides in and out quickly, enabling easy placement, removal and maneuver of full equipment racks during installation and service.

Ventilation

Built-in louvers for better air flow to keep equipment cool.

Soft-Close Doors

COOLING & ACCESS

STORAGE

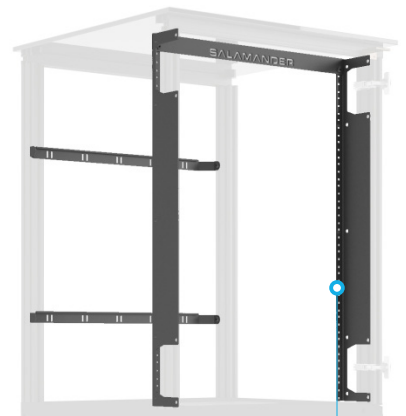

15-U RACK RAILS

Rack Rails are mounted to cabinet frame, for industry standard 19" rack mounting components.

Includes lacing bar for cable management.



ACTIVE COOLING

Automatic, low-noise cooling system.

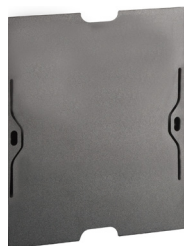

PINCH-OUT REARS

Permit fast, easy access to components and wiring.

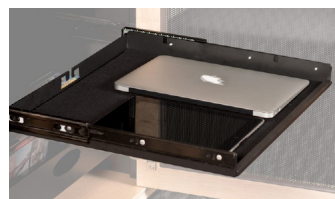

PULL-OUT TRAY

Adjustable position.

6 BAY CREDENZAS

Interior Bays Measure: 21"W x 27"H x 21"D

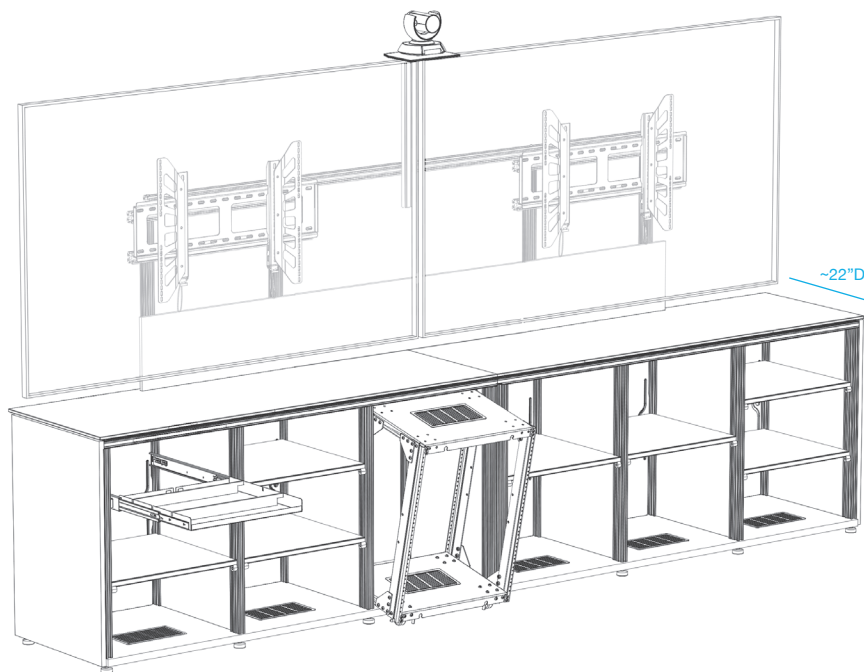

6-Bay, Credenza Dual Monitor Bundle

***D2/367BM2/**

- Dual Monitor Mount:
Holds (2) 55-90", 175 lbs (80kg) ea.
- Single Camera Shelf
- (1) Pull-Out Storage Tray
- (7) Adjustable Shelves
- (1) 13-U Pull-Out Rack Cartridge
- (5) Removable Rear Panels
- (1) Active Cooling Rear Panel

** Ships as two credenzas to be mated together.*

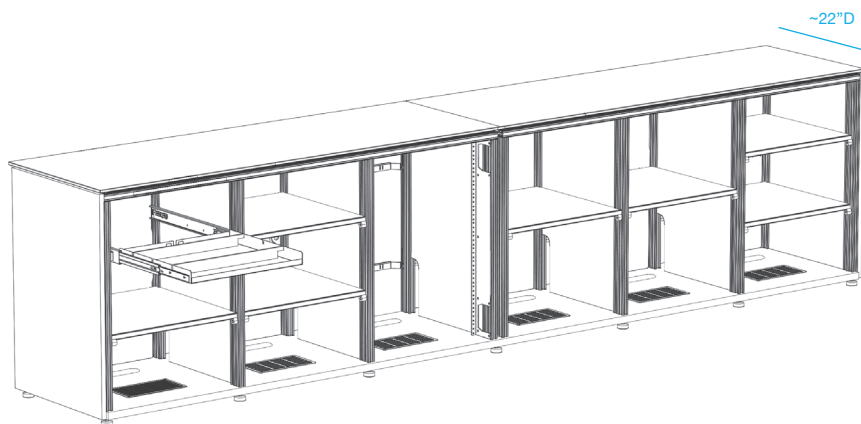

6-Bay, Credenza No Monitor Bundle

***D2/367A/**

- (1) Pull-Out Storage Tray
- (7) Adjustable Shelves
- (1) 15-U Rack Rails
- (5) Removable Rear Panels
- (1) Active Cooling Rear Panel

** Ships as two credenzas to be mated together.*

4 BAY CREDENZAS

ONE STEP
BUNDLES

Interior Bays Measure: 21"W x 27"H x 21"D

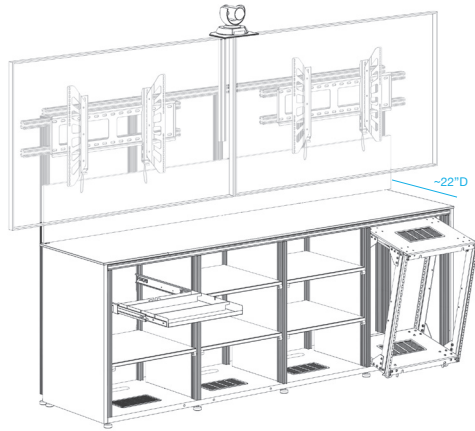

4-Bay, Credenza, Dual Monitor Bundle D2/347BM2/

- Dual Monitor Mount:
Holds (2) 55-90", 175 lbs ea. (80kg) ea.
- Single Camera Shelf
- (1) Pull-Out Storage Tray
- (5) Adjustable Shelves
- (1) 13-U Pull-Out Rack Cartridge
- (3) Removable Rear Panels
- (1) Active Cooling Rear Panel

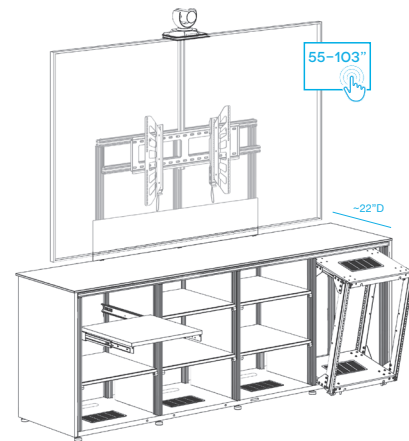

4-Bay, Credenza, Single Monitor Bundle D2/347BM1/

- Single Monitor Mount:
Holds 50-103", 175 lbs (80kg)
- Single Camera Shelf
- (1) Pull-Out Storage Tray
- (5) Adjustable Shelves
- (1) 13-U Pull-Out Rack Cartridge
- (3) Removable Rear Panels
- (1) Active Cooling Rear Panel

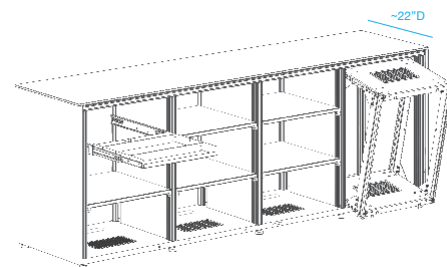

4-Bay, Credenza, No Monitor Bundle D2/347A/

- (1) Pull-Out Storage Tray
- (5) Adjustable Shelves
- (1) 15-U Rack Rails
- (3) Removable Rear Panels
- (1) Active Cooling Rear Panel

3 BAY CREDENZAS

Interior Bays Measure: 21"W x 27"H x 21"D

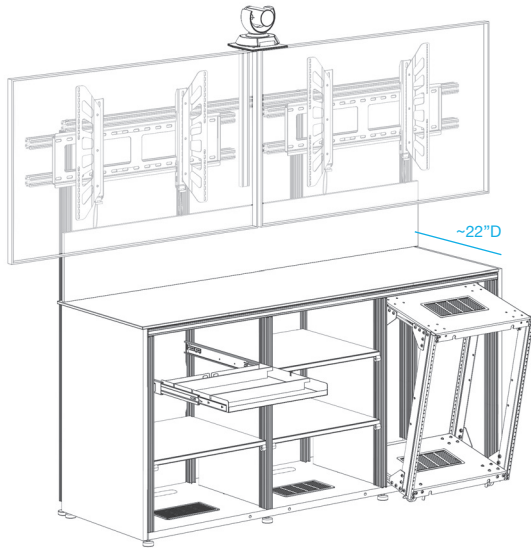

3-Bay, Credenza Dual Monitor Bundle D2/337BM2/

- Dual Monitor Mount:
Holds (2) 50-60", 175 lbs ea. (80kg) ea.
- Single Camera Shelf
- (1) Pull-Out Storage Tray
- (3) Adjustable Shelves
- (1) 13-U Pull-Out Rack Cartridge
- (2) Removable Rear Panels
- (1) Active Cooling Rear Panel

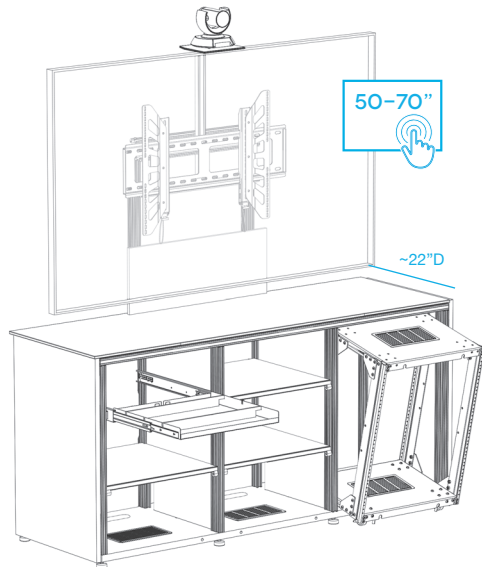

3-Bay, Credenza Single Monitor Bundle D2/337BM1/

- Single Monitor Mount:
Holds 50-70", 175 lbs (80kg)
- Single Camera Shelf
- (1) Pull-Out Storage Tray
- (3) Adjustable Shelves
- (1) 13-U Pull-Out Rack Cartridge
- (2) Removable Rear Panels
- (1) Active Cooling Rear Panel

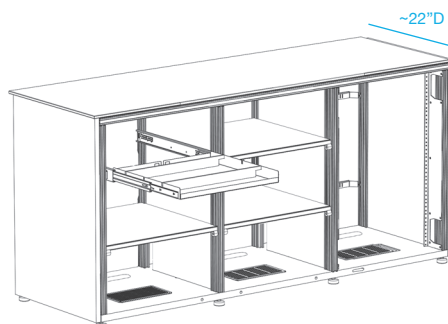

3-Bay, Credenza No Monitor Bundle D2/337A/

- (1) Pull-Out Storage Tray
- (3) Adjustable Shelves
- (1) 15-U Rack Rails
- (2) Removable Rear Panels
- (1) Active Cooling Rear Panel

CREDENZAS

ONE STEP
BUNDLES

	BERLIN Wenge, Wave-Texture Doors with 1/2" (12 mm) Black Solid Surface	CHICAGO Black Oak, Grass-Textured Doors with 1/2" (12 mm) Black Solid Surface	DENVER WAL- NUT Medium Walnut, Bark-Textured Doors with 1/2" (12 mm) Black Solid Surface	DENVER OAK Natural Oak, Bark-Textured Doors with 1/2" (12 mm) Black Solid Surface	MIAMI Gloss Warm White Door, with 1/2" (12 mm) Black Solid Surface	MIAMI Gloss Warm White Door, with 1/2" (12 mm) White Solid Surface
6-Bay, Credenza Dual Monitor Bundle 129.5"W x 31.25"H x 21.25"D	D2/367BM2/BL/WE	D2/367BM2/CH/OB	D2/367BM2/DV/MW	D2/367BM2/DV/NO	D2/367BM2/MM/GW/BK	D2/367BM2/MM/GW/WH
6-Bay, Credenza No Monitor Bundle 129.5"W x 31.25"H x 21.25"D	D2/367A/BL/WE	D2/367A/CH/OB	D2/367A/DV/MW	D2/367A/DV/NO	D2/367A/MM/GW/BK	D2/367A/MM/GW/WH
4-Bay, Credenza Dual Monitor Bundle 85.5"W x 31.25"H x 21.25"D	D2/347BM2/BL/WE	D2/347BM2/CH/OB	D2/347BM2/DV/MW	D2/347BM2/DV/NO	D2/347BM2/MM/GW/BK	D2/347BM2/MM/GW/WH
4-Bay, Credenza Single Monitor Bundle 85.5"W x 31.25"H x 21.25"D	D2/347BM1/BL/WE	D2/347BM1/CH/OB	D2/347BM1/DV/MW	D2/347BM1/DV/NO	D2/347BM1/MM/GW/BK	D2/347BM1/MM/GW/WH
4-Bay, Credenza No Monitor Bundle 85.5"W x 31.25"H x 21.25"D	D2/347A/BL/WE	D2/347A/CH/OB	D2/347A/DV/MW	D2/347A/DV/NO	D2/347A/MM/GW/BK	D2/347A/MM/GW/WH
3-Bay, Credenza Dual Monitor Bundle 64.75"W x 31.25"H x 21.25"D	D2/337BM2/BL/WE	D2/337BM2/CH/OB	D2/337BM2/DV/MW	D2/337BM2/DV/NO	D2/337BM2/MM/GW/BK	D2/337BM2/MM/GW/WH
3-Bay, Credenza Single Monitor Bundle 64.75"W x 31.25"H x 21.25"D	D2/337BM1/BL/WE	D2/337BM1/CH/OB	D2/337BM1/DV/MW	D2/337BM1/DV/NO	D2/337BM1/MM/GW/BK	D2/337BM1/MM/GW/WH
3-Bay, Credenza No Monitor Bundle 64.75"W x 31.25"H x 21.25"D	D2/337A/BL/WE	D2/337A/CH/OB	D2/337A/DV/MW	D2/337A/DV/NO	D2/337A/MM/GW	D2/337A/MM/GW/WH

	ZURICH Linear Texture - Opium Brown Doors with 1/2" (12 mm) Black Solid Surface	OSLO Black Glass Doors, Black Oak Sides with 1/2" (12 mm) Black Solid Surface	BARCELONA -WALNUT/BLACK Natural Walnut, Black Glass Doors, Beveled Edge Top	BARCELONA -WALNUT/WHITE Natural Walnut, Warm White Doors, Beveled Edge Top
6-Bay, Credenza Dual Monitor Bundle 129.5"W x 31.25"H x 21.25"D	D2/367BM2/ZU/OB	D2/367BM2/OS/BG	NA	NA
6-Bay, Credenza No Monitor Bundle 129.5"W x 31.25"H x 21.25"D	D2/367A/ZU/OB	D2/367A/OS/BG	NA	NA
4-Bay, Credenza Dual Monitor Bundle 86.5"W x 34.5"H x 22"D	D2/347BM2/ZU/OB	D2/347BM2/OS/BG	D2/347BM2/BA/NW/BG	D2/347BM2/BA/NW/GW
4-Bay, Credenza Single Monitor Bundle 86.5"W x 34.5"H x 22"D	D2/347BM1/ZU/OB	D2/347BM1/OS/BG	D2/347BM1/BA/NW/BG	D2/347BM1/BA/NW/GW
4-Bay, Credenza No Monitor Bundle 86.5"W x 34.5"H x 22"D	D2/347A/ZU/OB	D2/347A/OS/BG	D2/347A/BA/NW/BG	D2/347A/BA/NW/GW
3-Bay, Credenza Dual Monitor Bundle 65.75"W x 34.5"H x 22"D	D2/337BM2/ZU/OB	D2/337BM2/OS/BG	D2/337BM2/BA/NW/BG	D2/337BM2/BA/NW/GW
3-Bay, Credenza Single Monitor Bundle 65.75"W x 34.5"H x 22"D	D2/337BM1/ZU/OB	D2/337BM1/OS/BG	D2/337BM1/BA/NW/BG	D2/337BM1/BA/NW/GW
3-Bay, Credenza No Monitor Bundle 65.75"W x 34.5"H x 22"D	D2/337A/ZU/OB	D2/337A/OS/BG	D2/337A/BA/NW/BG	D2/337A/BA/NW/GW

WALL CABINETS

ONE STEP BUNDLES

Low-profile, shallow depth credenzas are sleek, streamlined solutions for supporting AV/IT technology. Our innovative design conceals all equipment and cables, and simple installation allows them to be affixed to any wall without special preparation. A unique, shallow depth provides a comfortable working position for interactive display users.

*ADA COMPLIANT



D1/337AM1/BLWE

Low-Profile, Wall Cabinet Bundles include a selection of our most popular options.

ONE STEP
BUNDLES

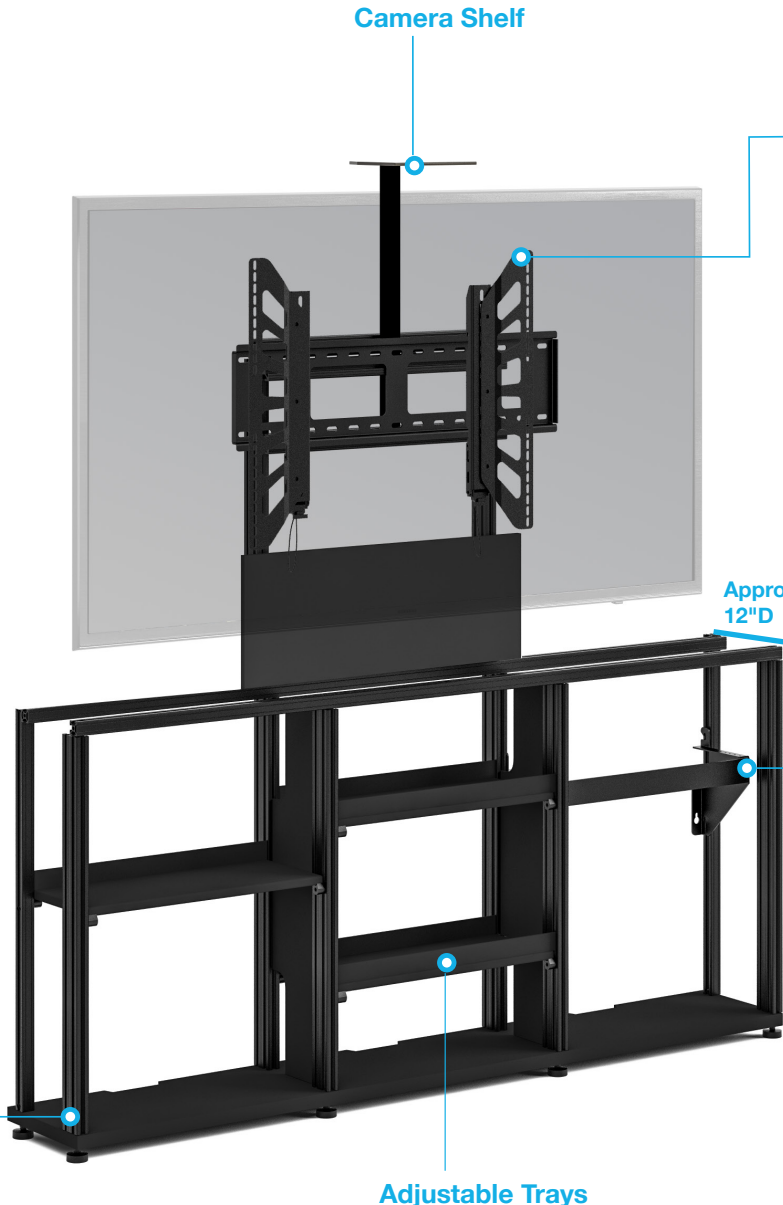

Camera Shelf

VIDEO

SINGLE OR DUAL MONITOR

Integrated mount with black modesty panel and camera shelf.

VESA Complaint:

Horizontal: 200 - 800mm

Vertical: 200 - 500mm

Adjustable Center of Screen settings:

61.5" / 59.75" / 58" / 56"

SINGLE XL MONITOR

Heavy duty, integrated mount with black modesty panel.

VESA Complaint:

Horizontal: 400 - 1200mm

Vertical: 400 - 600mm

EZ-TOUCH MOUNTS

Effortless, manual assist lift and lift/tilt mounts with our patented design features spring-assisted counterbalance technology.

VESA Complaint: 600 x 400mm

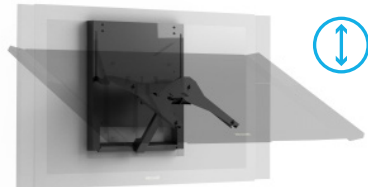

Aluminum Frame

Durable and flexible support chassis.

Adjustable Trays

RACK MOUNTING

3-U VERTICAL RACK

Rack is mounted to cabinet frame, for industry standard 19" pro audio rack mounting.

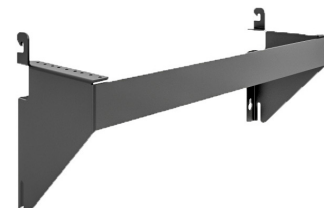

6 BAY, LOW-PROFILE WALL CABINETS

Interior Bays Measure: 21"W x 27"H x 11"D

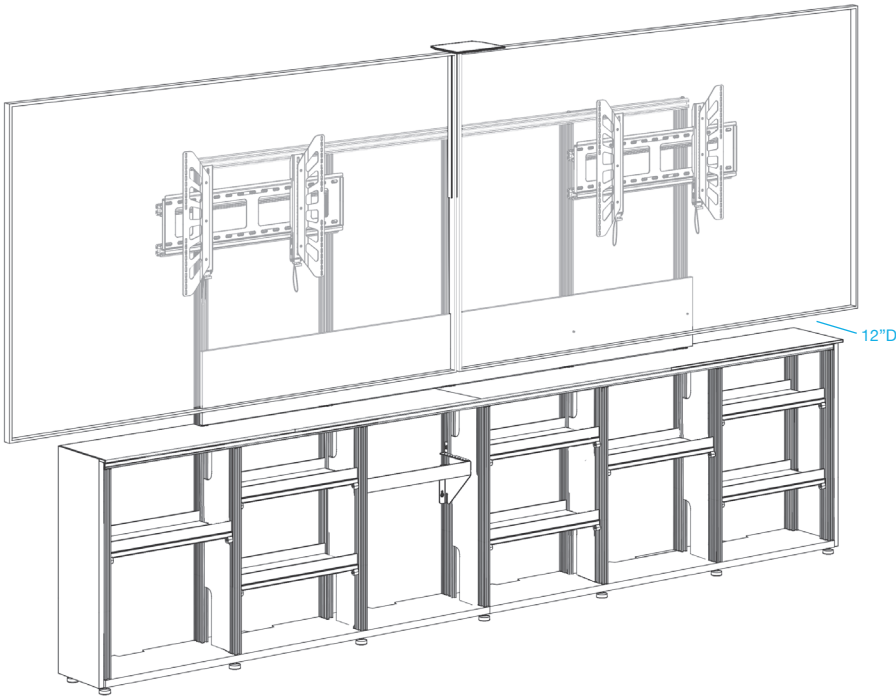

6-Bay, Low-Profile Wall Cabinet Dual Monitor Bundle

***D1/367AM2/**

- Dual Monitor Mount:
Holds (2) 55-90", 125 lbs (57kg) ea.
- Single Camera Shelf
- (8) Adjustable Trays
- (1) 3-U Vertical Rack Rail

** Ships as two credenzas to be mated together.**

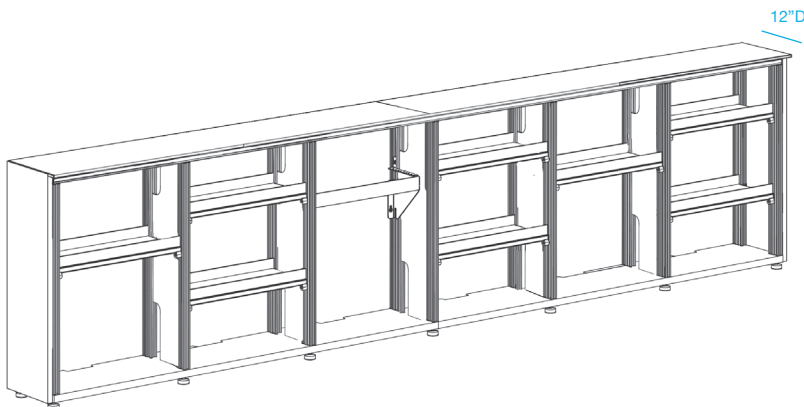

6-Bay, Low-Profile Wall Cabinet No Monitor Bundle

***D1/367A/**

- (8) Adjustable Trays
- (1) 3-U Vertical Rack Rail

** Ships as two credenzas to be mated together.**

4 BAY, LOW-PROFILE WALL CABINETS

ONE STEP
BUNDLES

Interior Bays Measure: 21"W x 27"H x 11"D

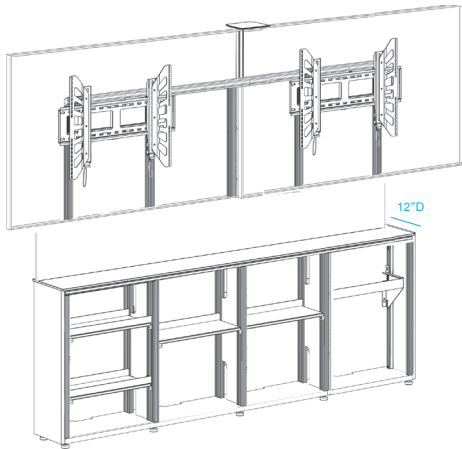

4-Bay, Low-Profile Wall Cabinet Dual Monitor Bundle

[D1/347AM2/](#)

- Dual Monitor Mount:
Holds (2) 55-90", 125 lbs (57kg) ea.
- Single Camera Shelf
- (4) Adjustable Trays
- (1) 3-U Vertical Rack Rail

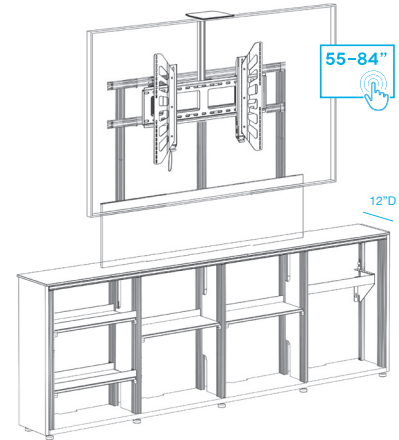

4-Bay, Low-Profile Wall Cabinet Single Monitor Bundle

[D1/347AM1/](#)

- Single Monitor Mount:
Holds 50-103", 175 lbs (80kg)
- Single Camera Shelf
- (4) Adjustable Trays
- (1) 3-U Vertical Rack Rail

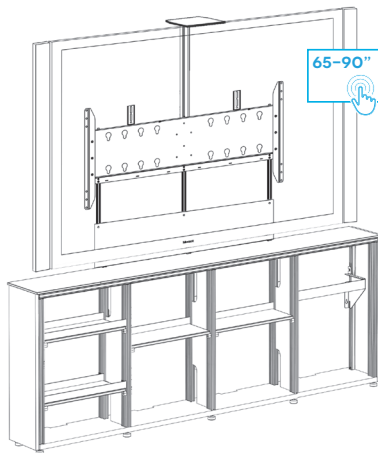

4-Bay, Low-Profile Wall Cabinet Single XL Monitor Bundle

[D1/347AMXL/](#)

- XL Monitor Mount: Holds 65-90", 300 lbs (136 kg)
- Designed to accommodate the 84" Microsoft Surface Hub
- Single Camera Shelf
- (4) Adjustable Trays
- (1) 3-U Vertical Rack Rail

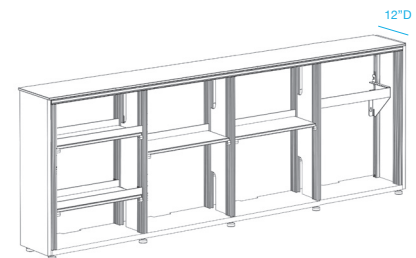

4-Bay, Low-Profile Wall Cabinet No Monitor Bundle

[D1/347A/](#)

- (4) Adjustable Trays
- (1) 3-U Vertical Rack Rail

3 BAY, LOW-PROFILE WALL CABINETS

Interior Bays Measure: 21"W x 27"H x 11"D

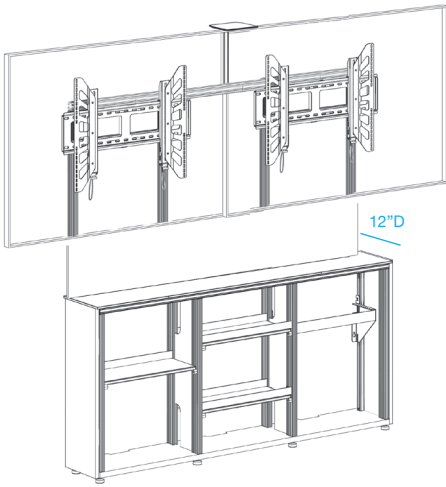

3-Bay, Low-Profile Wall Cabinet Dual Monitor Bundle
D1/337AM2/

- Dual Monitor Mount: Holds (2) 50-60", 125 lbs (57kg) ea.
- Single Camera Shelf
- (3) Adjustable Trays
- (1) 3-U Vertical Rack

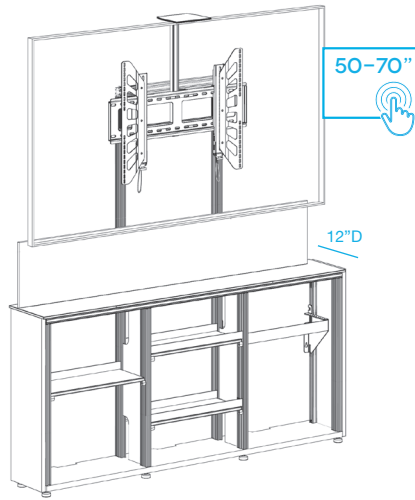

3-Bay, Low-Profile Wall Cabinet Single Monitor Bundle
D1/337AM1/

- Single Monitor Mount: Holds 50-70", 175 lbs (80kg)
- Single Camera Shelf
- (3) Adjustable Trays
- (1) 3-U Vertical Rack

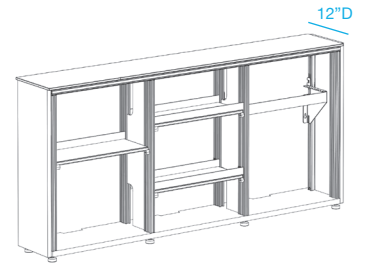

3-Bay, Low-Profile Wall Cabinet No Monitor Bundle
D1/337A/

- (3) Adjustable Trays
- (1) 3-U Vertical Rack

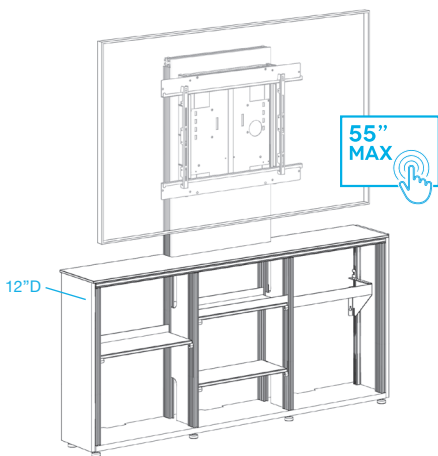

3-Bay, Low-Profile Wall Cabinet EZ-Touch Lift Mount
D1/337AL/

- EZ-Touch Lift Mount: Holds up to 55", 81-145 lbs (37-66kg)
- (3) Adjustable Trays
- (1) 3-U Vertical Rack

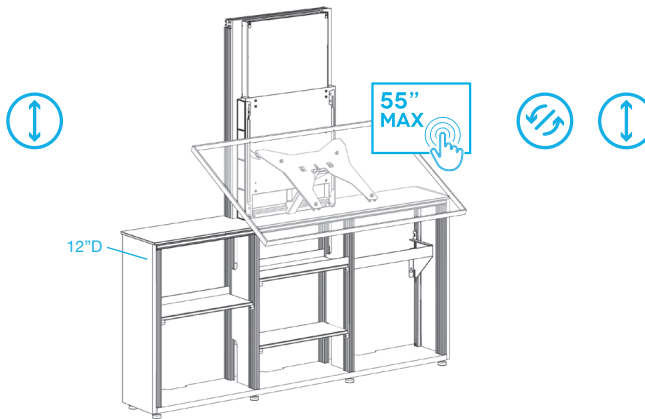

3-Bay, Low-Profile Wall Cabinet EZ-Touch Lift & Tilt Mount
D1/337ALT/

- EZ-Touch Lift & Tilt Mount: Holds up to 55" Max, 48 - 112 lbs
- (3) Adjustable Trays
- (1) 3-U Vertical Rack

LOW-PROFILE WALL CABINETS

ONE STEP
BUNDLES

	BERLIN Wenge, Wave-Texture Doors with 1/2" (12 mm) Solid Surface Black Top	CHICAGO Black Oak, Grass-Textured Doors with 1/2" (12 mm) Solid Surface Black Top	DENVER WALNUT Medium Walnut, Bark-Textured Doors with 1/2" (12 mm) Solid Surface Black Top	DENVER OAK Natural Oak, Bark-Textured Doors with 1/2" (12 mm) Solid Surface Black Top
6-Bay, Low-Profile, Wall Cabinet Dual Monitor Bundle 129.5"W x 31.25"H x 12"D	D1/367AM2/BL/WE	D1/367AM2/CH/OB	D1/367AM2/DV/MW	D1/367AM2/DV/NO
6-Bay, Low-Profile, Wall Cabinet No Monitor Bundle 129.5"W x 31.25"H x 12"D	D1/367A/BL/WE	D1/367A/CH/OB	D1/367A/DV/MW	D1/367A/DV/NO
4-Bay, Low-Profile, Wall Cabinet Dual Monitor Bundle 85.5"W x 31.25"H x 12"D	D1/347AM2/BL/WE	D1/347AM2/CH/OB	D1/347AM2/DV/MW	D1/347AM2/DV/NO
4-Bay, Low-Profile, Wall Cabinet Single Monitor Bundle 85.5"W x 31.25"H x 12"D	D1/347AM1/BL/WE	D1/347AM1/CH/OB	D1/347AM1/DV/MW	D1/347AM1/DV/NO
4-Bay, Low-Profile, Wall Cabinet Single XL Monitor Bundle 85.5"W x 31.25"H x 12"D	D1/347AMXL/BL/WE	D1/347AMXL/CH/OB	D1/347AMXL/DV/MW	D1/347AMXL/DV/NO
4-Bay, Low-Profile, Wall Cabinet No Monitor Bundle 64.75"W x 31.25"H x 12"D	D1/347A/BL/WE	D1/347A/CH/OB	D1/347A/DV/MW	D1/347A/DV/NO
3-Bay, Low-Profile, Wall Cabinet Dual Monitor Bundle 64.75"W x 31.25"H x 12"D	D1/337AM2/BL/WE	D1/337AM2/CH/OB	D1/337AM2/DV/MW	D1/337AM2/DV/NO
3-Bay, Low-Profile, Wall Cabinet Single Monitor Bundle 64.75"W x 31.25"H x 12"D	D1/337AM1/BL/WE	D1/337AM1/CH/OB	D1/337AM1/DV/MW	D1/337AM1/DV/NO
3-Bay, Low-Profile, Wall Cabinet No Monitor Bundle 64.75"W x 31.25"H x 12"D	D1/337A/BL/WE	D1/337A/CH/OB	D1/337A/DV/MW	D1/337A/DV/NO

	MIAMI Gloss Warm White Door, with 1/2" (12 mm) Solid Surface Black Top	MIAMI Gloss Warm White Door, with 1/2" (12 mm) White Solid Surface	ZURICH Opium Brown Linear Texture Doors with 1/2" (12 mm) Solid Surface Black Top	OSLO Black Glass Doors with Black Oak Sides, 1/2" (12 mm) Solid Surface Black Top
6-Bay, Low-Profile, Wall Cabinet Dual Monitor Bundle 129.5"W x 31.25"H x 12"D	D1/367AM2/MM/GW/BK	D1/367AM2/MM/GW/WH	D1/367AM2/ZU/OB	D1/367AM2/OS/BG
6-Bay, Low-Profile, Wall Cabinet No Monitor Bundle 129.5"W x 31.25"H x 12"D	D1/367A/MM/GW/BK	D1/367A/MM/GW/WH	D1/367A/ZU/OB	D1/367A/OS/BG
4-Bay, Low-Profile, Wall Cabinet Dual Monitor Bundle 85.5"W x 31.25"H x 12"D	D1/347AM2/MM/GW/BK	D1/347AM2/MM/GW/WH	D1/347AM2/ZU/OB	D1/347AM2/OS/BG
4-Bay, Low-Profile, Wall Cabinet Single Monitor Bundle 85.5"W x 31.25"H x 12"D	D1/347AM1/MM/GW/BK	D1/347AM1/MM/GW/WH	D1/347AM1/ZU/OB	D1/347AM1/OS/BG
4-Bay, Low-Profile, Wall Cabinet Single XL Monitor Bundle 85.5"W x 31.25"H x 12"D	D1/347AMXL/MM/GW/BK	D1/347AMXL/MM/GW/WH	D1/347AMXL/ZU/OB	D1/347AMXL/OS/BG
4-Bay, Low-Profile, Wall Cabinet No Monitor 64.75"W x 31.25"H x 12"D	D1/347A/MM/GW/BK	D1/347A/GW/WH	D1/347A/ZU/OB	D1/347A/OS/BG
3-Bay, Low-Profile, Wall Cabinet Dual Monitor Bundle 64.75"W x 31.25"H x 12"D	D1/337AM2/MM/GW/BK	D1/337AM2/MM/GW/WH	D1/337AM2/ZU/OB	D1/337AM2/OS/BG
3-Bay, Low-Profile, Wall Cabinet Single Monitor Bundle 64.75"W x 31.25"H x 12"D	D1/337AM1/MM/GW/BK	D1/337AM1/MM/GW/WH	D1/337AM1/ZU/OB	D1/337AM1/OS/BG
3-Bay, Low-Profile, Wall Cabinet No Monitor Bundle 64.75"W x 31.25"H x 12"D	D1/337A/MM/GW/BK	D1/337A/MM/GW/WH	D1/337A/ZU/OB	D1/337A/OS/BG

STYLES

We select the finest materials and finishes. Choose from sleek, hand-polished, high-gloss finishes to richly textured real wood fronts or a contemporary beveled edge style with a mix of materials.

If you are looking for something different or special please contact us to discuss custom options.

TEXTURED



BERLIN
Wenge, Wave-Texture
Doors with 1/2" (12mm) Black,
Solid Surface



CHICAGO
Black Oak, Grass-Textured
Doors with 1/2" (12mm) Black,
Solid Surface



DENVER - OAK
Natural Oak, Bark-Textured
Doors with 1/2" (12mm) Black,
Solid Surface



DENVER - WALNUT
Medium Walnut, Bark-Textured
Doors with 1/2" (12mm) Black,
Solid Surface



ZURICH
Opium Brown, Linear-Texture -
Doors with 1/2" (12mm) Black,
Solid Surface

BLACK & WHITE



OSLO
Black Glass Doors with Black
Oak Sides, 1/2" (12mm) Black,
Solid Surface



MIAMI
Gloss Warm White Door,
Doors with 1/2" (12mm) Black,
Solid Surface



MIAMI
Gloss Warm White Door,
Doors with 1/2" (12mm) White
Solid Surface

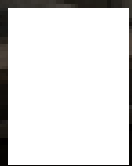

MOTORIZED STANDS & MOUNTS

FPS1XL/EL/GG

Innovative furniture and mounting solutions seamlessly integrate with touch screens to add functionality, flexibility, and style to collaborative workspaces. These advanced solutions provide accessible, comfortable, and ergonomically correct touchscreen positioning, improving productivity and enhancing user experience.

MOBILE STANDS

Salamander Designs creates fully adjustable, electric lift, mobile stands that offer convenience, flexibility, and designer style. The sleek, compact design moves easily between spaces and is designed for touch screen in working, drafting, collaboration, and presentation positions. Accessories include rack-mounted equipment storage, retractable cable reel and more.



Shown with 84" screen.

FPS1XL/EL/GG
XL Electric Lift Mobile Stand

VESA COMPLIANT:
Horizontal 400, 600, 800, 1000, 1200mm
Vertical 400, 500, 600mm

WEIGHT CAPACITY:
300 lbs (136 kgs)



***Road Case:**
FPSA/RC/XL
Accommodates Stand
& Microsoft 84" Surface Hub



Shown with 55" screen.

FPS1/EL/GG
Electric Lift Mobile Stand

VESA COMPLIANT:
Horizontal 200, 300, 400, 600mm
Vertical 200, 300, 400mm

WEIGHT CAPACITY:
175 lbs (79 kgs)



***Road Case:**
FPSA/RC/EL
Accommodates Stand
& Microsoft 55" Surface Hub



Shown with 55" screen.

FPS1/ELT/GG
Electric Lift & Tilt Mobile Stand

VESA COMPLIANT:
Horizontal 200, 300, 400, 600mm
Vertical 200, 300, 400mm

WEIGHT CAPACITY:
175 lbs (79 kgs)



***Road Case:**
FPSA/RC/ELT
Accommodates Stand
& Microsoft 55" Surface Hub

*ROAD CASE EQUIPMENT FOR EASY DEPLOYMENT

Combine a mobile stand with a road case to provide secure and convenient transport of your display.



MOBILE STANDS FEATURES & ACCESSORIES



ACCESSORIES

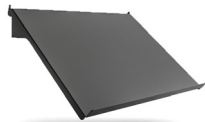

Keyboard Storage Shelf
FPSA/KS/GT

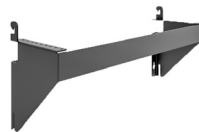

Rack Mounting Equipment Bracket
FPSA/VR/3U



Retractable Power Cable Reel
FPSA/CR



Power Distribution Unit, 9 Outlets
SA/RM/PDU



Secure Equipment Storage Cover
FPSA/SC/GT



Small Shelf with Mounting Straps
FPSA/AS1



Wireless Remote Control with Memory
FPSA/RF1

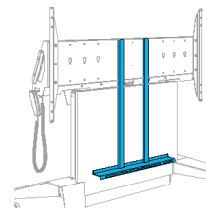

SpeakerBracket
FPSA/SBK

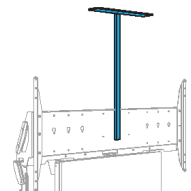

Camera Shelf
FPSA/CS

WALL STANDS

Electric-lift, wall stand features an accessible, compact, low profile design that conceals all equipment and cabling. Easy to install and secure to any wall.



FPS1W/EL/GG

Electric Lift Stand

VESA COMPLIANT:

Horizontal 200 - 800mm
Vertical 200 - 500mm

WEIGHT CAPACITY:

175 lbs (79 kgs)



ACCESSORIES



Camera Shelf
FPSA/CS



Wireless Remote
Control with Memory
FPSA/RF1

WALL MOUNTS

Low profile wall mounts.



- Installation is easy thanks to our Lift-n-Load design
- Simple wall mounting, complete with high-grade wall and TV hardware
- Includes security lock

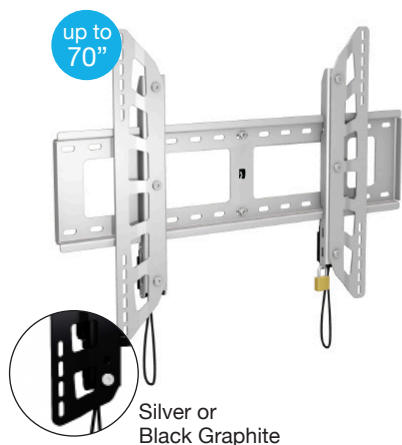

Silver or
Black Graphite

PL100/L

Flat Mount, Large Silver

PL100/L/BK

Flat Mount, Large Black

SCREENS: 32-70"

WEIGHT CAPACITY:

175 lbs (79 kgs)

VESA COMPLIANT:

Horizontal 200 - 800mm
Vertical 200 - 500mm

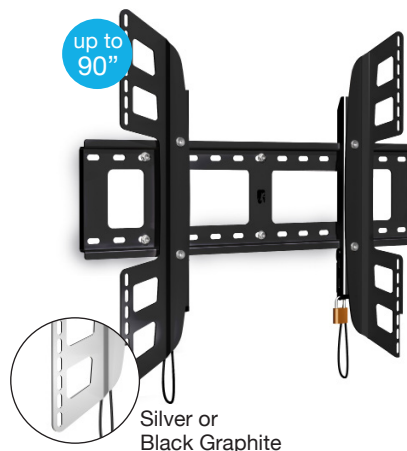

Silver or
Black Graphite

FX100/XL

Flat / Tilt Mount
Combo - Silver

FX100/XL/BK

Flat / Tilt Mount
Combo - Black

Includes both flat
and tilt brackets

SCREENS: 50-90" *

WEIGHT CAPACITY:

175 lbs (79 kgs)

VESA COMPLIANT:

Horizontal 300 -900mm
Vertical 300 - 600mm

* Not for use with 84" Microsoft Surface Hub.

EZ-TOUCH MOUNTS™

Salamander Designs EZ Touch Wall Mounts provide effortless, manual high/low adjustment which is hidden behind the touch screen. Our patented design features spring-assisted counterbalance technology.

EZ1/ML360

EZ Touch Wall Mount
Manual Assist Lift
Range of Travel 25.6" (650mm)

VESA COMPLIANT:

1200 x 600mm

WEIGHT CAPACITY:

196 - 361 lbs (89 - 164 kgs)



EZ1/ML145

EZ Touch Wall Mount
Manual Assist Lift
Range of Travel 15.75" (400mm)

VESA COMPLIANT:

Horizontal 200 - 800mm
Vertical 100 - 440mm

WEIGHT CAPACITY:

81 - 145 lbs (37 - 66 kgs)

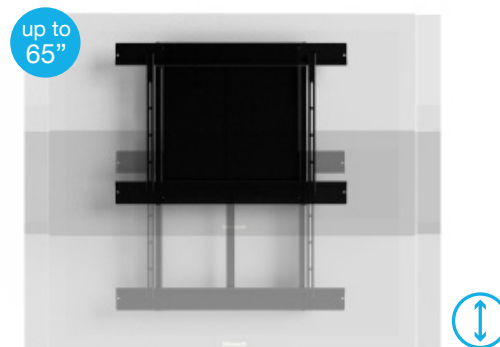

EZ1/MLT112

EZ Touch Wall Mount
Manual Assist Lift & Tilt
Range of Travel 15.75" (400mm)
Drafting position 60 degrees
55" Max Display

VESA COMPLIANT:

Horizontal 400, 600mm
Vertical 400mm

WEIGHT CAPACITY:

48 - 112 lbs (22 - 51 kgs)

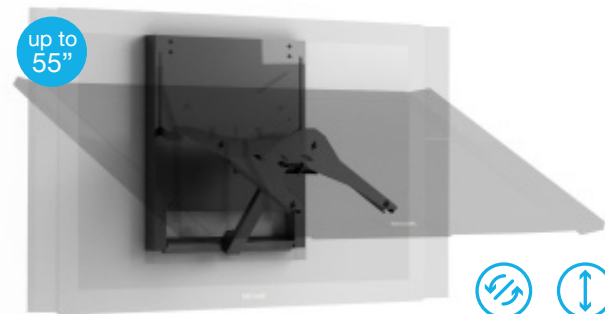

CAN'T FIND IT? WE'LL BUILD IT

Salamander offers fully customizable cabinet systems for a wide range of applications.

You start with the frame then choose a style and customize with functional features...

Power and Data Ports, Integrated Speakers, Wall Mounting Kits, Footing options, hospitality solutions that include **Built-In Refrigerator**, a **Coffee Station** and much more.



Custom 367



Custom 236



Custom 345



Custom 237



* ADA COMPLIANT

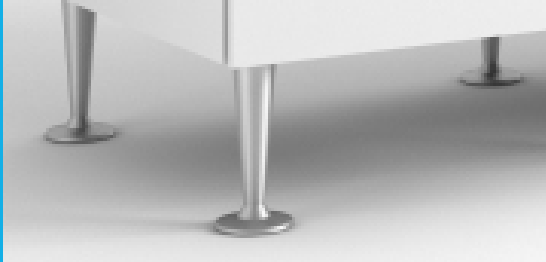

The Americans with Disability Act (ADA) Standards for Accessible Design was adopted by the Department of Justice to help create buildings and facilities that are accessible to more than 50 million Americans with disabilities.

The ADA requires that all new construction of places of public accommodation and commercial facilities be accessible. These include a wide range of entities, such as office buildings, and public spaces. The proper furniture selection can help to provide compliance for accessibility.

For example: Section 307: Protruding Objects. If your Display monitor is wall-mounted and has nothing below it to alert someone with visual impairments navigating with a cane to its presence, it can have a maximum depth of 4 inches from the wall. Simply by specifying an integrated cabinet below the display can provide compliance.

If you are considering a technology deployment or are making updates to an existing space, these requirements may apply. Ignoring them can put your business or organization at risk for legal action.

ADA Standards for Accessible Design, US Department of Justice 2010 Standards: Titles II and III; Chapter 3: Building Blocks Relevant Sections: 307 Protruding Objects, 308 Reach Ranges, 309 Operable Parts.

For more information:
https://www.ada.gov/2010ADASTandards_index.htm





CUSTOM MADE EASY

Salamander specializes in custom designing and manufacturing high-performing furniture solutions for complex projects.

Call us for a free design consultation.

WEB: salamanderdesigns.com/commercial

EMAIL: custom@salamanderdesigns.com

PHONE: 800-535-9910



SALAMANDER
DESIGNS

Furniture Shaped By Your Needs ®