

Package Contents

- Dual Gang Wall Mount
- (x4) #6-32 Machine Screws
- Plastic Front Cover
- (x2) T8H Torx Security Screw
- *AP-205H-MNT2 Wall Mount Kit Installation Guide*

Introduction

The AP-205H-MNT2 Wall Mount Kit provides a secure and practical solution for mounting the AP-205H to single and dual gang wall boxes.

Installing the AP-205H-MNT2 Wall Mount Kit

Use the following instructions to install the AP-205H-MNT2 Wall Mount Kit.

1. If the wall box is not already exposed, unscrew and remove the existing wall plate, as shown in [Figure 1](#).

Figure 1 *Removing Existing Wall Plate*

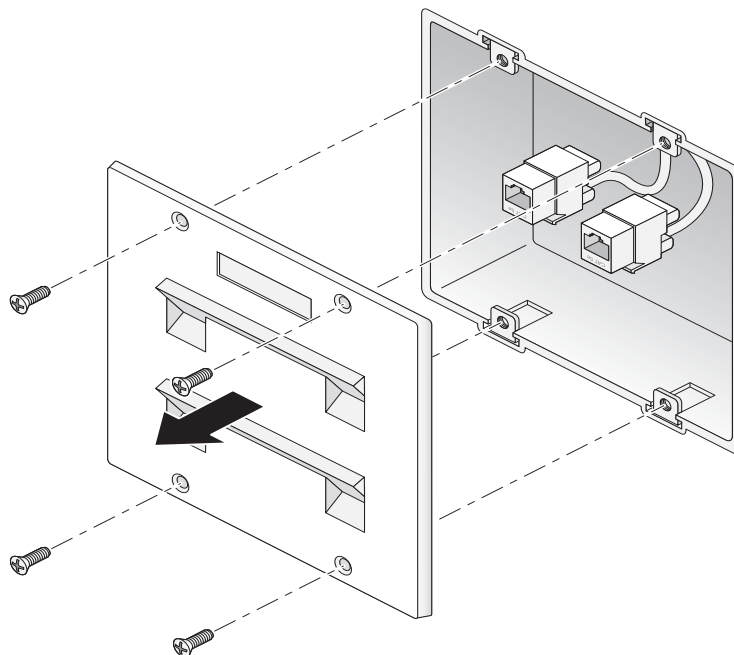

2. Detach any RJ45 cables by unclipping the connectors from the wall plate, or cutting/removing the UTP cable(s).
3. Use a short Ethernet cable (sold separately, part number AP-CBL-ETH10) to connect the E0 port to an RJ45 connector, or crimp an RJ45 plug (not supplied) to the cable, and insert into the E0 port. Do the same for the PT port if used.

Installation for Single Gang Wall Box

If mounting the AP-205H-MNT2 Wall Mount Kit to a single gang wall box, refer to steps 4-5.

4. Align the screw holes on the mounting bracket with the corresponding holes on the single gang wall box, as indicated in [Figure 2](#).

Figure 2 Attaching Wall Mount to Single Gang Wall Box

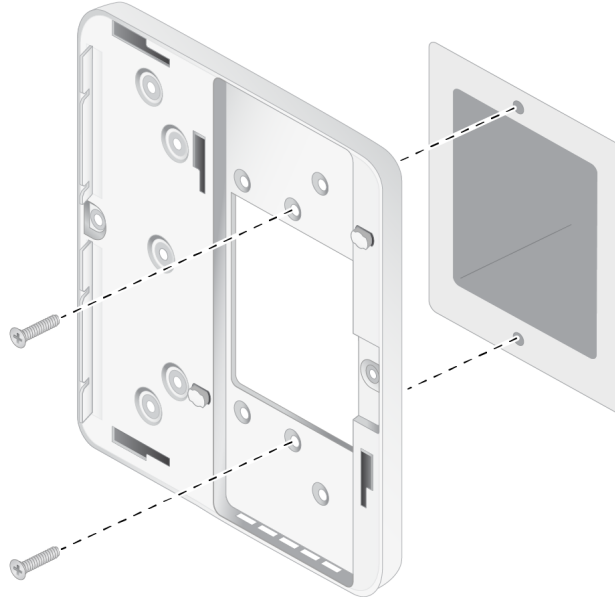

5. Remove the #6-32 x 1 machine screws from their bag and screw the wall mount onto the wall box.

Installation for Dual Gang Wall

If mounting the AP-205H-MNT2 Wall Mount Kit to a dual gang wall box, refer to steps 6-7.

6. Align the screw holes on the mounting bracket with the corresponding holes on the dual gang wall box, as indicated in [Figure 3](#).

Figure 3 Attaching Wall Mount to Dual Gang Wall Box

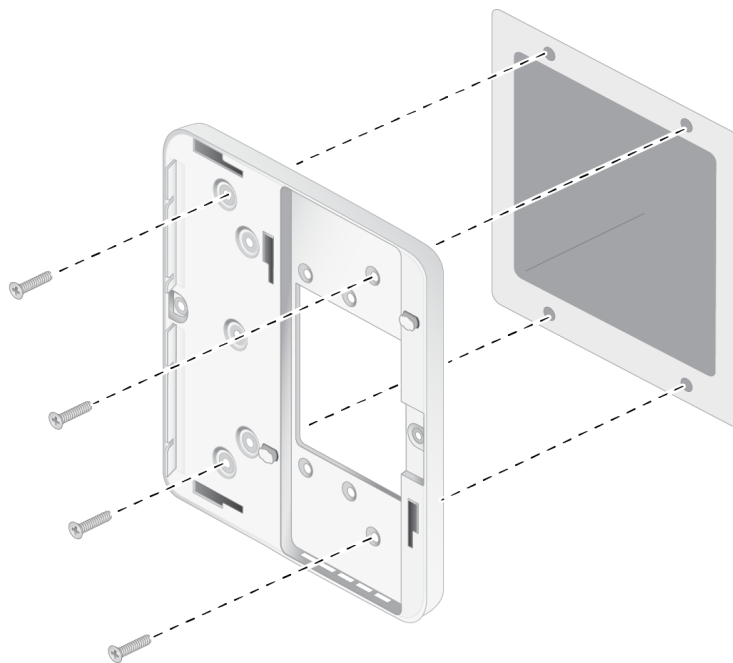

7. Remove the #6-32 screws from their bag and screw the wall mount onto the wall box, as shown in [Figure 3](#).
8. Connect any required cables to the rear of the AP.
9. Align the mounting slots on the back of your AP-205H with the corresponding posts on the wall mount as shown in [Figure 4](#).

Figure 4 *Securing AP-205H to Wall Mount*

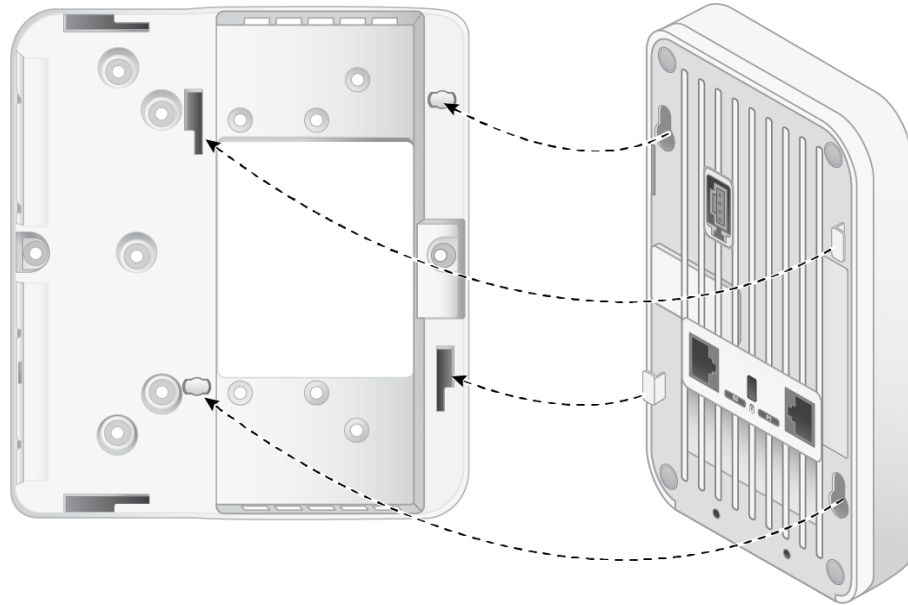

10. Push the AP against the holes and then downward until the posts engage the slots at the top of the mounting holes.
11. (Optional) Using the second T8H Torx security screw provided, insert into the hole on the upper-right side of the mount and tighten to lock the AP-205H into the mount.
12. Position the prongs on the back of the front cover inside the slots on the front mount housing, as shown in [Figure 5](#).

Figure 5 *Fitting Front Cover onto Wall Mount*

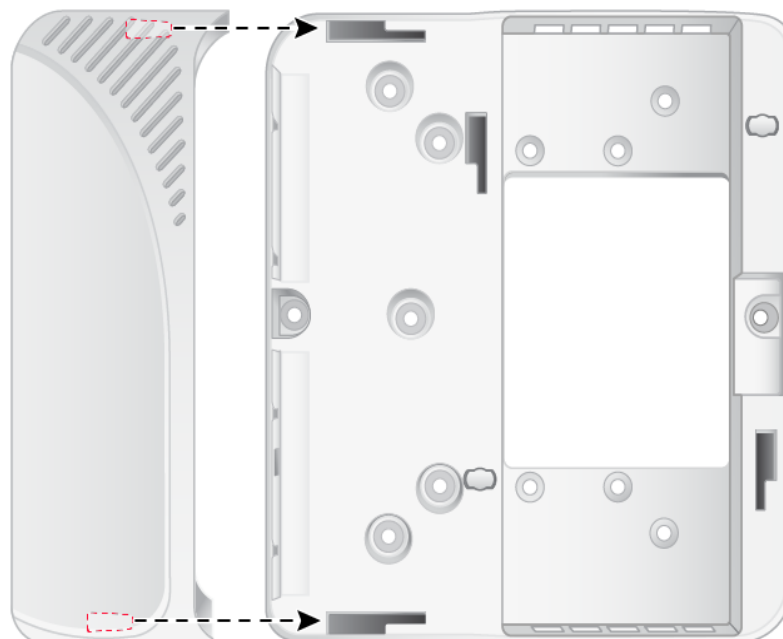

- Slide the cover into the tracks toward the AP until the left side of the cover is level with the side of the mount. Refer to [Figure 6](#), demonstrating the cover sliding from open position (left) to locked position (right).

Figure 6 Plastic Side Cover Sliding into Wall Mount (Rear View)

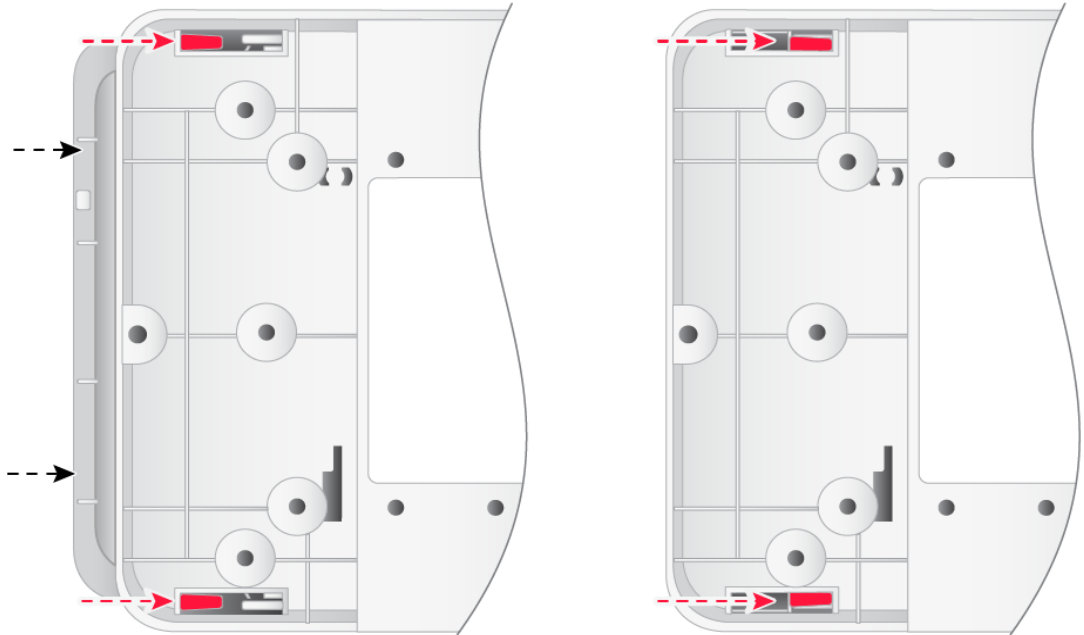

- (Optional) Once the front cover is securely attached to the mount, insert one of the T8H Torx Security Screw into the hole located at the left side of the cover and tighten until secure.
- (Optional) If not using PoE, connect the AC-DC power adapter (sold separately, part number AP-CBL-SER) to the DC power socket located on the right of the AP-205H.

