

# INSTALLATION INSTRUCTIONS

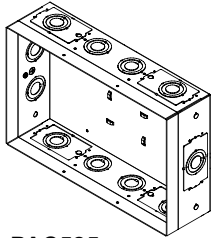

PAC525

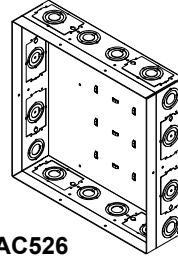

PAC526

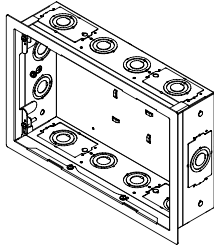

PAC525F

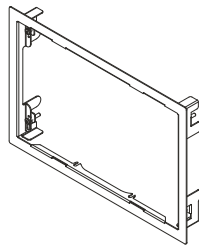

PAC525F-KIT

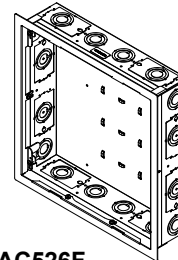

PAC526F

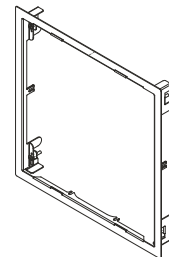

PAC526F-KIT

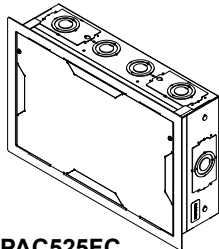

PAC525FC

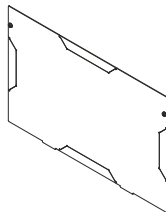

PAC525CVR-KIT

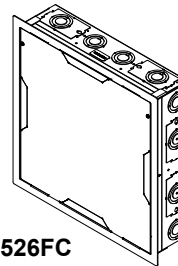

PAC526FC

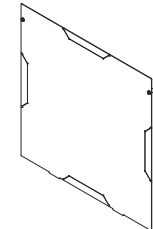

PAC526CVR-KIT

## In-Wall Accessory Boxes

# CHIEF<sup>®</sup>

A brand of  legrand<sup>®</sup>

# PAC525/526

## DISCLAIMER

Legrand | AV and its affiliated corporations and subsidiaries (collectively "Legrand | AV"), intend to make this manual accurate and complete. However, Legrand | AV makes no claim that the information contained herein covers all details, conditions or variations, nor does it provide for every possible contingency in connection with the installation or use of this product. The information contained in this document is subject to change without notice or obligation of any kind. Legrand | AV makes no representation of warranty, expressed or implied, regarding the information contained herein. Legrand | AV assumes no responsibility for accuracy, completeness or sufficiency of the information contained in this document.

Chief® is a registered trademark of Legrand AV Inc.

## DEFINITIONS

**MOUNTING SYSTEM:** A MOUNTING SYSTEM is the primary Chief product to which an accessory and/or component is attached.

**ACCESSORY:** AN ACCESSORY is the secondary Chief product which is attached to a primary Chief product, and may have a component attached or setting on it.

**COMPONENT:** A COMPONENT is an audiovisual item designed to be attached or resting on an accessory or mounting system such as a video camera, CPU, screen, display, projector, etc.



**WARNING:** A WARNING alerts you to the possibility of serious injury or death if you do not follow the instructions.



**CAUTION:** A CAUTION alerts you to the possibility of damage or destruction of equipment if you do not follow the corresponding instructions.



## IMPORTANT SAFETY INSTRUCTIONS



**WARNING:** Failure to read, thoroughly understand, and follow all instructions can result in serious personal injury, damage to equipment, or voiding of factory warranty! It is the installer's responsibility to make sure all accessories are properly assembled and installed using the instructions provided.



**WARNING:** Failure to provide adequate structural strength for this accessory can result in serious personal injury or damage to equipment! It is the installer's responsibility to make sure the structure to which this accessory is attached can support five times the combined weight of all equipment. Reinforce the structure as required before installing the accessory.



**WARNING:** Exceeding the weight capacity can result in serious personal injury or damage to equipment! It is the installer's responsibility to make sure the combined weight of all components located in the accessory does not exceed 10 lbs (4.5 kg).

- Each PAC525/526 may hold up to 2 complete backplanes and each individual backplane may hold a maximum weight of 10 lbs (4.5 kg).
- A half backplane (after separation) may hold a maximum weight of 5 lbs (2.3 kg).



**WARNING:** Use this accessory only for its intended use as described in these instructions. Do not use attachments not recommended by the manufacturer.



**WARNING:** Never operate this accessory if it is damaged. Return the accessory to a service center for examination and repair.



**WARNING:** For indoor use only.

**IMPORTANT ! :** The PAC525/526 accessory is designed to be mounted to either a 2" x 3" or 2" x 4" wood stud wall 16" on center, or a 2" x 3"-25ga (minimum) or 2" x 4"-25ga (minimum) steel studs wall.

**NOTE:** Spacings - Minimum spacings between the 120 Vac power components and the A/V components shall be maintained for safe operation of the equipment when installed in accordance with the National Electric Code, ANSI/NFPA 70.

**NOTE:** When selecting a Listed 120 Vac Receptacle for use as the main power source for the PAC series boxes (to power the A/V equipment), make sure that AC Receptacle is rated at least 15A and it is used in the building's AC branch circuit that is connected to a circuit breaker rated at least 15A. Do not connect more than 12A from the Receptacle.

In the U.S., the equipment shall be installed per the applicable requirements of the National Electrical Code, CSA C22.1.

In Canada, the equipment shall be installed per the applicable requirements of the National Electrical Code, ANS/NFPA 70.

**NOTE:** It is the installer's responsibility to ensure that the enclosure is bonded to the ground in the switch box, in accordance with the National Electric Code, ANSI/NFPA 70 or Canadian Electrical Code, CSA C22.1. A green grounding screw is provided in the enclosure for the purpose, if required.









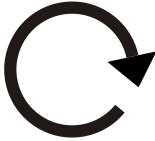

**--SAVE THESE INSTRUCTIONS--**

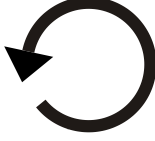
**DIMENSION DRAWINGS** are located at the end of these Installation Instructions.

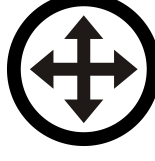
**TABLE OF CONTENTS**

		Installation Instructions
DISCLAIMER.....	2	Adding Template/Temporary Cover.....9
DEFINITIONS.....	2	PAC525/526F-KIT.....9
IMPORTANT SAFETY INSTRUCTIONS.....	2	PAC525/526CVR-KIT.....10
TABLE OF CONTENTS.....	3	Dimensions - PAC525.....11
LEGEND.....	4	Dimensions - PAC525F.....11
TOOLS REQUIRED FOR INSTALLATION....	5	Dimensions - PAC525FC.....12
PARTS INCLUDED.....	5	Dimensions - PAC525F-KIT.....12
ASSEMBLY AND INSTALLATION.....	6	Dimensions - PAC525CVR-KIT.....13
Locating PAC525/526.....	6	Dimensions - PAC526.....13
PAC525/526 Site Preparation.....	7	Dimensions - PAC526F.....14
PAC525/526 Box Preparation and Installation.	7	Dimensions - PAC526FC.....14
		Dimensions - PAC526F-KIT.....15
		Dimensions - PAC526CVR-KIT.....15

## LEGEND

	<b>Tighten Fastener</b> Apretar elemento de fijación Befestigungsteil festziehen Apertar fixador Serrare il fissaggio Bevestiging vastdraaien Serrez les fixations		<b>Pencil Mark</b> Marcar con lápiz Stiftmarkierung Marcar com lápis Segno a matita Potloodmerkteken Marquage au crayon
	<b>Loosen Fastener</b> Aflojar elemento de fijación Befestigungsteil lösen Desapertar fixador Allentare il fissaggio Bevestiging losdraaien Desserrez les fixations		<b>Drill Hole</b> Perforar Bohrloch Fazer furo Praticare un foro Gat boren Percez un trou
	<b>Phillips Screwdriver</b> Destornillador Phillips Kreuzschlitzschraubendreher Chave de fendas Phillips Cacciavite a stella Kruiskopschroevendraaier Tournevis à pointe cruciforme		<b>Adjust</b> Ajustar Einstellen Ajustar Regolare Afstellen Ajuster
	<b>Open-Ended Wrench</b> Llave de boca Gabelschlüssel Chave de bocas Chiave a punte aperte Steeksleutel Clé à fourche		<b>Remove</b> Quitar Entfernen Remover Rimuovere Verwijderen Retirez
	<b>By Hand</b> A mano Von Hand Com a mão A mano Met de hand À la main		<b>Optional</b> Opcional Optional Opcional Opzionale Optie En option
	<b>Hex-Head Wrench</b> Llave de cabeza hexagonal Sechskantschlüssel Chave de cabeça sextavada Chiave esagonale Zeskantsleutel Clé à tête hexagonale		<b>Security Wrench</b> Llave de seguridad Sicherheitsschlüssel Chave de segurança Chiave di sicurezza Veiligheidssleutel Clé de sécurité

**TOOLS REQUIRED FOR INSTALLATION**

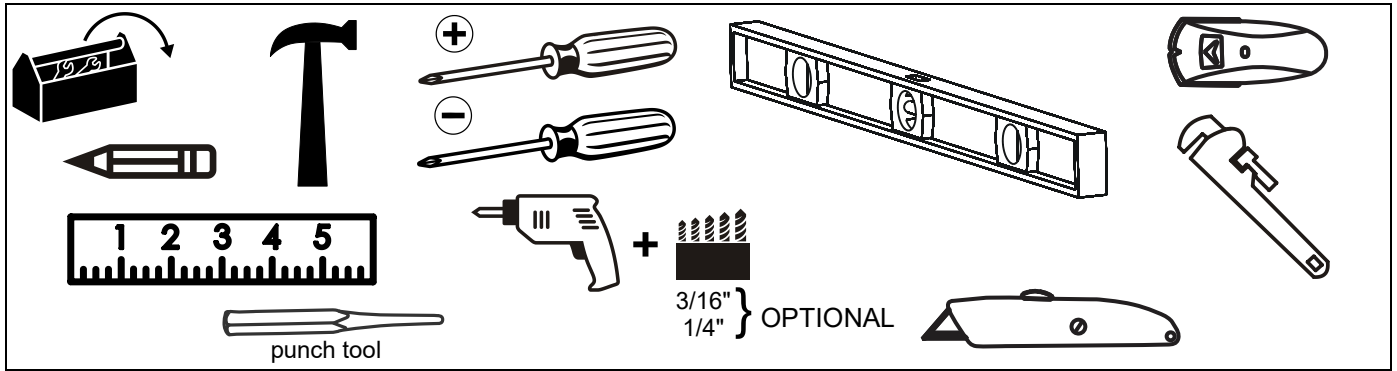

**PARTS INCLUDED**

**PAC525/526**

E (1)  
[PAC525/526]  
(PAC525 shown)

F (1)  
[Template/  
Temporary Cover]

A (4)  
1/4 x 2-1/2"

B (8)  
06-32"

C (8)  
06 x 3/8"

D (4)  
3/8"

**PAC525/526F**

G (1)  
[PAC525/526F]  
(PAC525 shown)

F (1)  
[Template/  
Temporary Cover]

A (4)  
1/4 x 2-1/2"

B (8)  
06-32"

C (8)  
06 x 3/8"

D (4)  
3/8"

**PAC525/526FC**

H (1)  
[PAC525/526FC]  
(PAC525 shown)

F (1)  
[Template/  
Temporary Cover]

A (4)  
1/4 x 2-1/2"

B (8)  
06-32"

C (8)  
06 x 3/8"

D (4)  
3/8"

**+ PAC525/526CVR-KIT (SEE PAGE 6)**

**PARTS - continued**

**PAC525/526F-KIT**

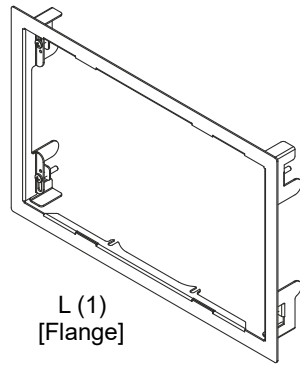

L (1)  
[Flange]



M (4 - PAC525, 6 - PAC526)  
10-24 x 1/4"

**PAC525/526CVR-KIT**

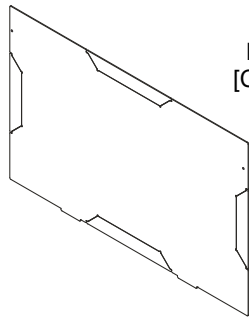

N (1)  
[Cover]



P (2)  
#06 x 1-1/4"

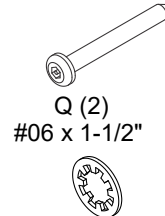

Q (2)  
#06 x 1-1/2"

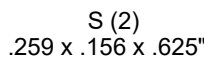

S (2)  
.259 x .156 x .625"



T (2)  
#06

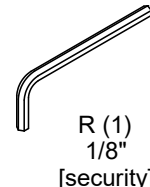

R (1)  
1/8"  
[security]

**Assembly And Installation**

**ASSEMBLY AND INSTALLATION**

**IMPORTANT ! :** In the following instructions, the reference to PAC525/526 includes the following models:

- PAC525
- PAC525F
- PAC525FC
- PAC526
- PAC526F
- PAC526FC

The PAC525/526 is intended for use in both installations where an existing finished drywall wall is present, and where the wall surface has not been finished and the structural studs are exposed. The box should be installed with an offset equal to the thickness of the drywall. The wall then must be finished around the opening of the box after the box has been installed.

**Locating PAC525/526**

1. Identify a suitable wall location for the accessory.
2. Locate and mark studs using a stud sensor.
3. Identify possible structural conflicts (electrical wiring, plumbing, gas lines, HVAC).



**WARNING:** ELECTRICAL SHOCK HAZARD! CUTTING OR DRILLING INTO ELECTRICAL WIRES OR CABLES CAN CAUSE DEATH OR SERIOUS PERSONAL INJURY! ALWAYS make certain area behind mounting surfaces is free of electrical wires and cables before cutting, drilling or installing fasteners.



**WARNING:** EXPLOSION AND FIRE HAZARD! CUTTING OR DRILLING INTO GAS PLUMBING CAN CAUSE DEATH OR SERIOUS PERSONAL INJURY. ALWAYS make certain area behind mounting surfaces is free of gas, water, waste or any other plumbing before cutting, drilling or installing fasteners.

4. Determine all additional/optional components required:
  - Conduit pipe
  - Conduit connectors (both large and small)
  - Electrical box(es) (3" x 2")
  - Steel electrical box cover(s)
  - Electrical outlet(s)

**WARNING:** All wiring should be performed by a licensed electrician following all local codes and ordinances.

### PAC52/526 Site Preparation

1. Using a level, draw a horizontal line at the lower edge of the install site. (See Figure 1)
2. Create an exploratory hole to confirm edge of the studs.
3. Using the line drawn in Step 1 as lower edge and placing between studs, use the enclosed template (F) to draw lines around corners of template, and connect lines on bottom, top and sides. (See Figure 1)

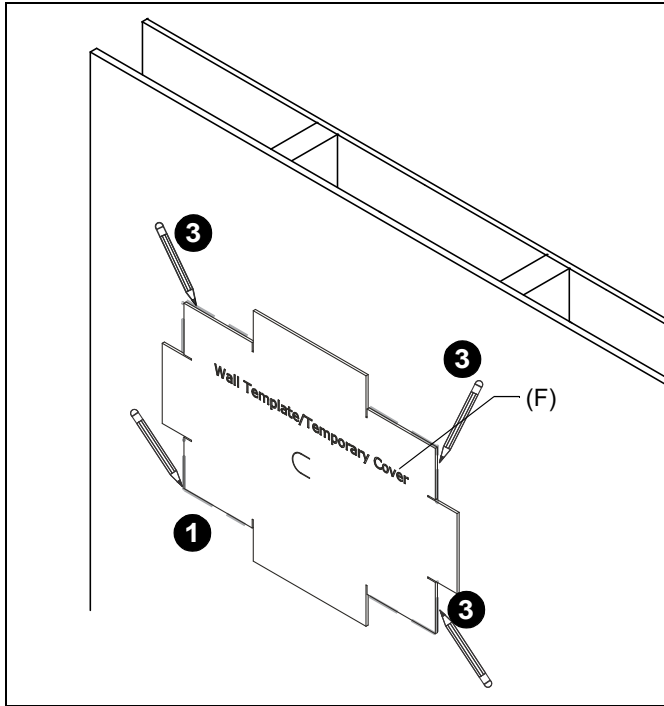

Figure 1

4. Cut along outside edge of line using a utility knife and remove drywall.
5. Check stud depth within the wall.
  - If 3-1/2" or greater, proceed to **PAC525/526 Box Preparation and Installation**.
  - If less than 3-1/2" deep, proceed to **Step 6**.
6. If present, remove box flange by loosening screws. (See Figure 2)



**CAUTION:** Injury may occur on sharp edges. Carefully discard the removable tabs. Avoid sharp edges.

7. Snap off removable tabs at perforations provided.
8. Reinstall box flange.
9. Fasten flange in place by tightening screws loosened in Step 6.

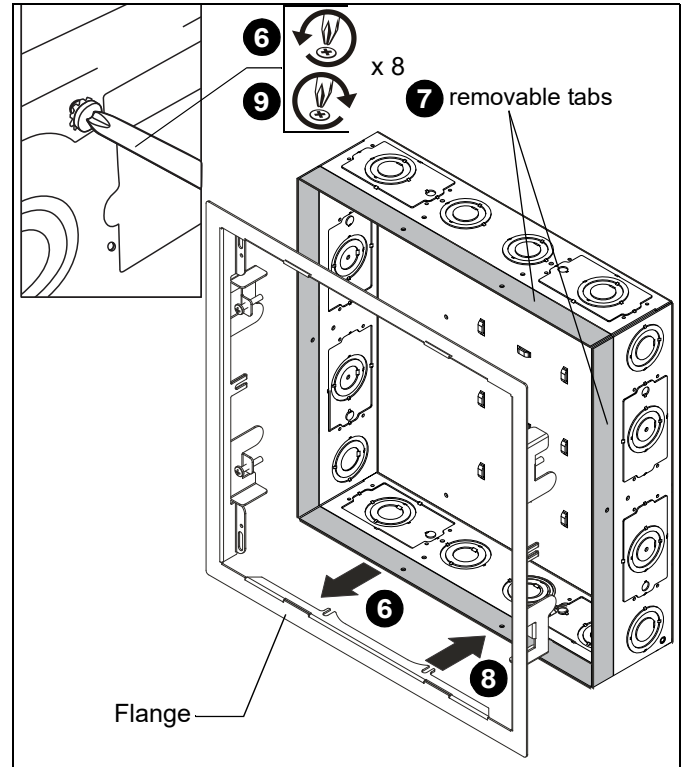

Figure 2

### PAC525/526 Box Preparation and Installation

Remove knock-outs as determined in Step 4 of **Locating PAC525/526** section. Use a punch and hammer to remove knock-outs using the following Steps 2-5. For further tips on how to remove the knock-outs refer to the video shown on [legrandav.com](http://legrandav.com).

**NOTE:** The knockouts must be punched in the direction they were originally punched. If the knockout is sticking in, punch it in from the outside. If the knockout is sticking out, punch it out from the inside.

1. Remove inner circle by knocking it out from the inside using a punch tool and hammer. Use locking pliers to remove from outside box. (See Figure 3)

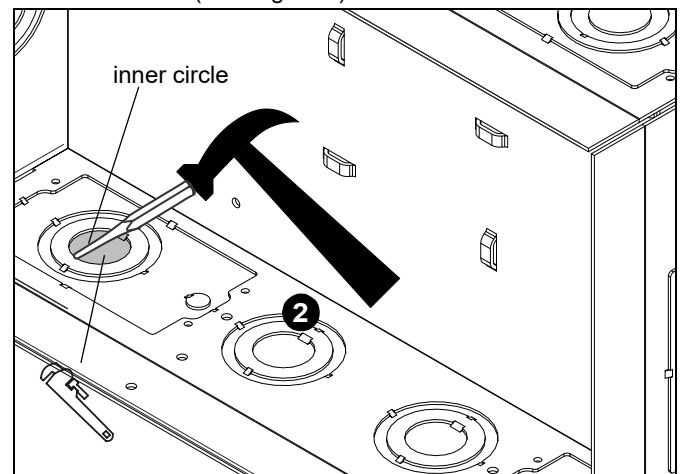

Figure 3

- Remove second circle by knocking it out from the outside using a punch tool and hammer. Use locking pliers to remove. (See Figure 4)

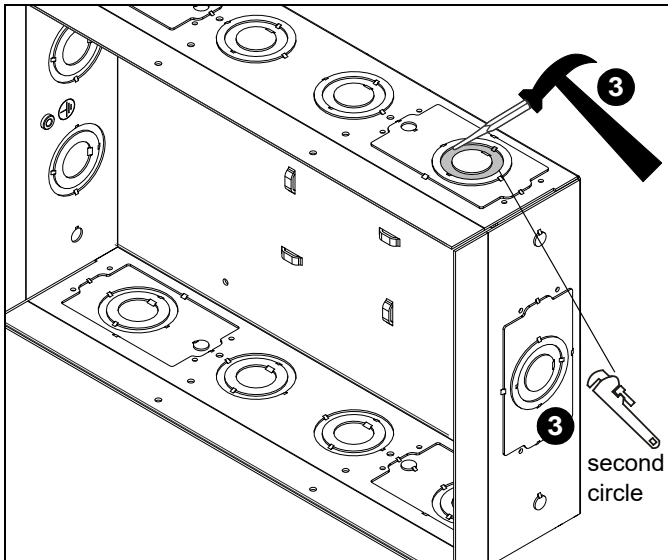

Figure 4

- Remove third circle by knocking it out from the inside using a punch tool and hammer. Use locking pliers to remove. (See Figure 5)

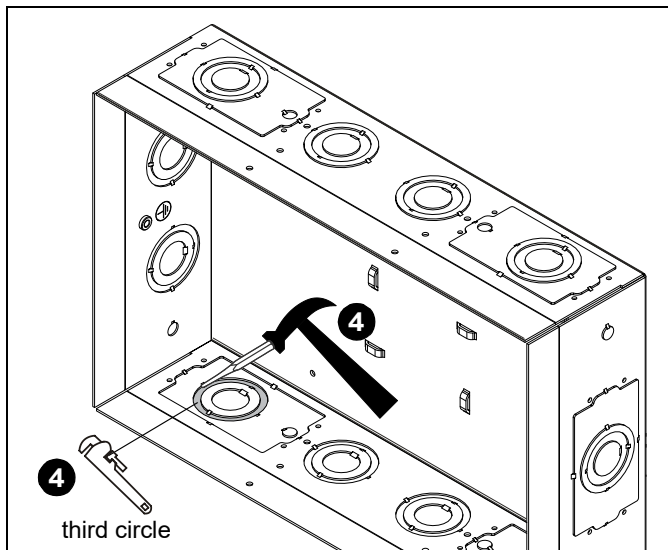

Figure 5

- Remove rectangular knock-out by using locking pliers through removed hole to bend knock-out as needed and maneuver until the tabs are broken and knock-out can be removed. (See Figure 6)

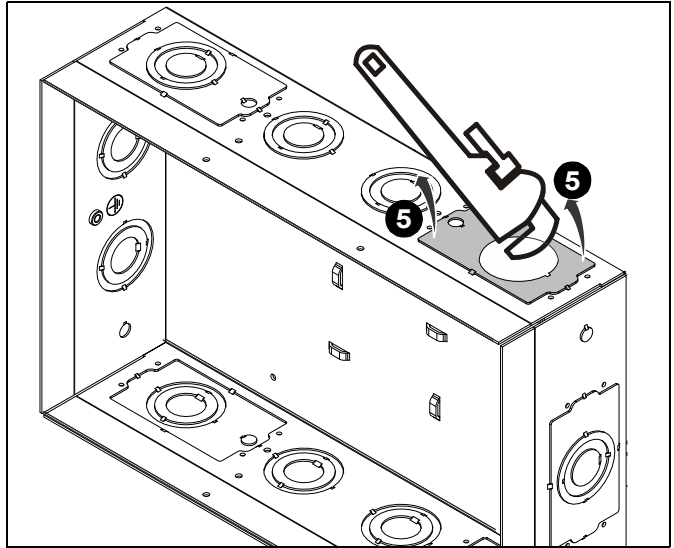

Figure 6

- Loosely attach required conduit and conduit connectors, switch boxes, outlets, etc (not included) to PAC525/526 to enable fitting into the wall opening. (See Figure 7)

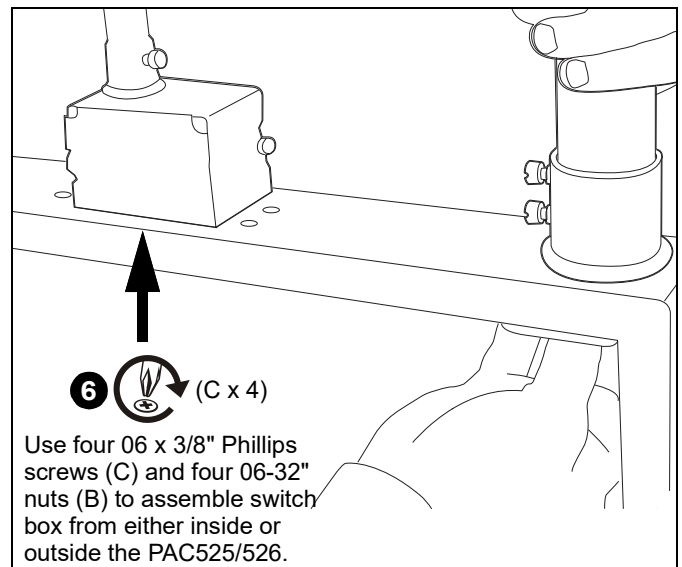

Figure 7

**IMPORTANT !** : The PAC525 can be installed either in landscape or portrait orientation.

- Feed conduit attached to PAC525/526 through cut-out in wall and insert PAC525/526 into wall opening. Tighten component connections.

7. Remove round holes using punch tool and hammer and drill pilot holes (at least 2 on each side of PAC525/526) into studs through mounting holes in PAC525/526.
  - Wood studs: use 3/16" drill bit
  - Steel studs: use 1/4" drill bit

**NOTE:** If installing model with flanges, the flanges include locking cleats which makes Steps 7-8 unnecessary.

8. Install PAC525/526 to studs using four 1/4 x 2-1/2" Phillips flat head screws (A) and four 3/8" flat washers (D) through PAC525/526 and pilot holes. (See Figure 8)

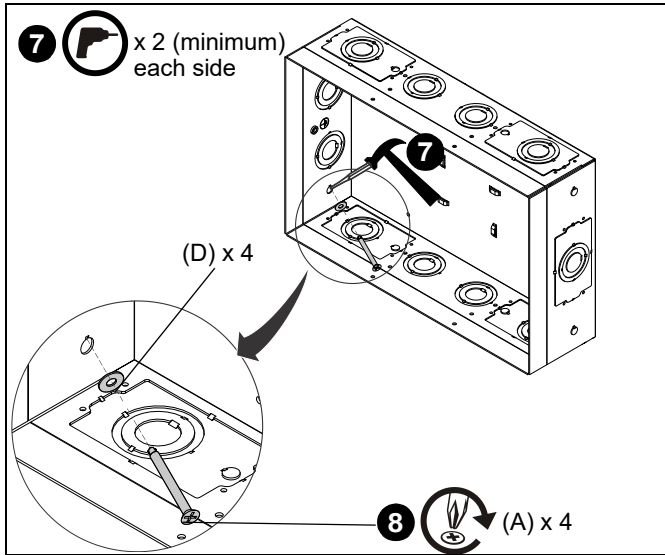

Figure 8

**NOTE:** If installing in a stud wall BEFORE the drywall is installed, remove outer flange from PAC525/526 before installing the PAC525/526.

**IMPORTANT ! :** PAC525/526 box must protrude out from the studs a distance equal to the depth of drywall. (See Figure 9)

9. (Flange models ONLY) Install flange (L) around PAC525/526 box. Tighten four screws in locked position to secure locking cleats. (See Figure 9)

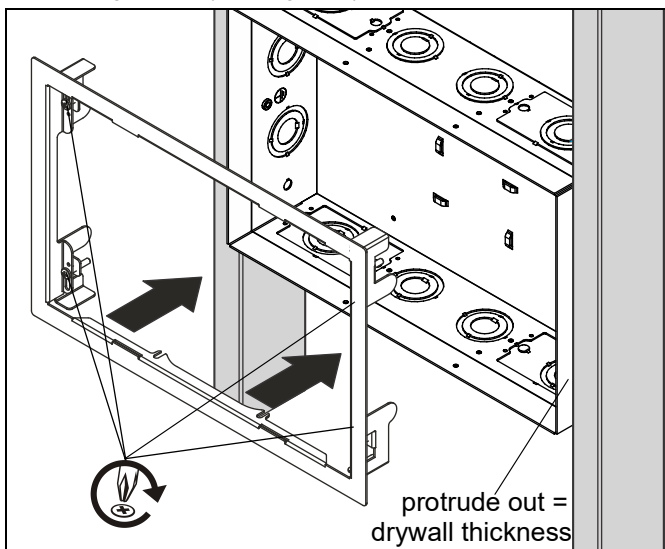

Figure 9

**Adding Template/Temporary Cover**

**NOTE: OPTIONAL:** Install template (F), if necessary, as a temporary cover to protect interior of PAC525/526 box from debris.

1. Fold tabs of template (F) in and insert into PAC525/526 opening. (See Figure 10)

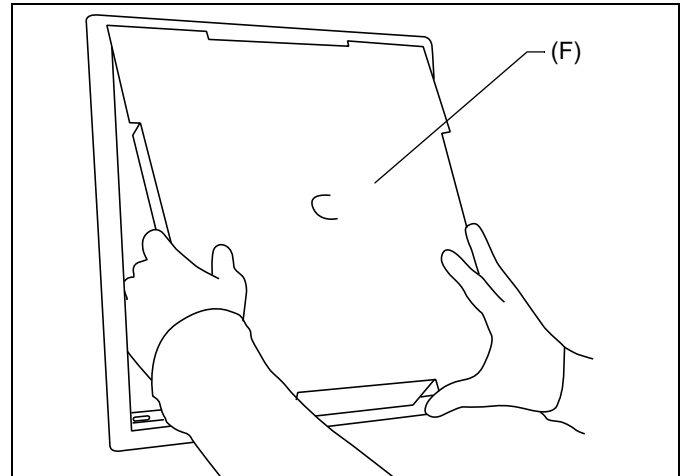

Figure 10

**PAC525/526F-KIT**

1. Loosely install eight 10-24 x 1/4" Phillips head screws with external teeth (M) into holes in PAC525/526 sides. (See Figure 11)

**NOTE:** If the outer edge of the PAC525/526 needs to be removed, use the inner hole for flange attachment. (See Figure 11)

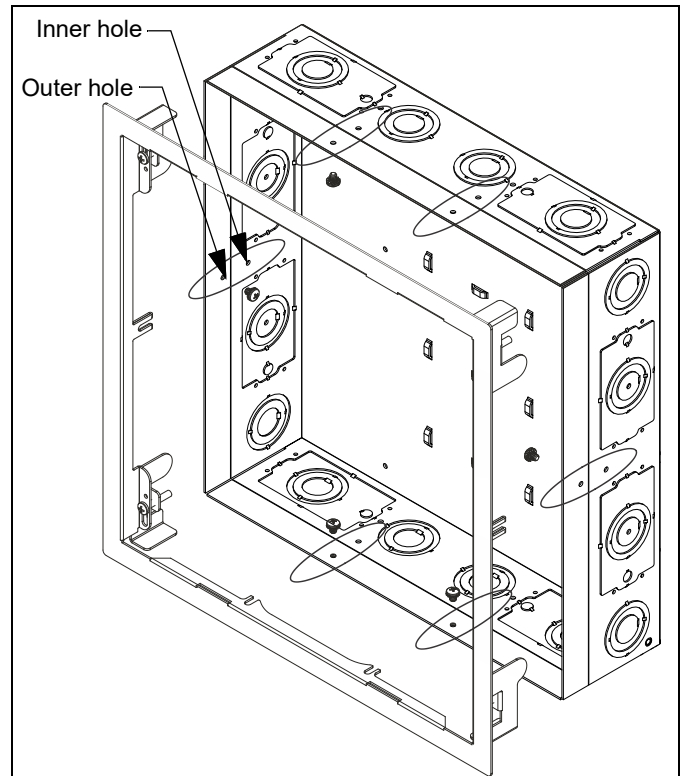

Figure 11

- Slide flange (L) into PAC525/526 over installed screws, and tighten screws. (See Figure 12)

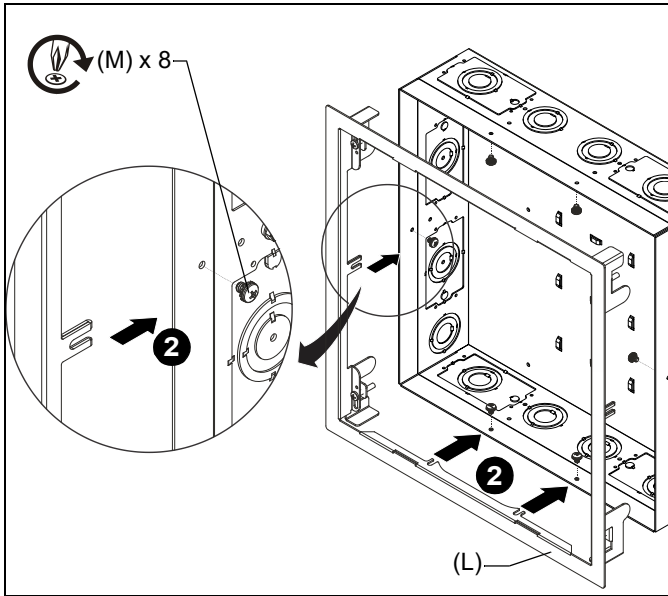

Figure 12

**PAC525CVR-KIT**

- Break away the tab(s) on the cover (N) to allow wire exit from the PAC525/526, and to meet ventilation needs of the components. (See Figure 13)

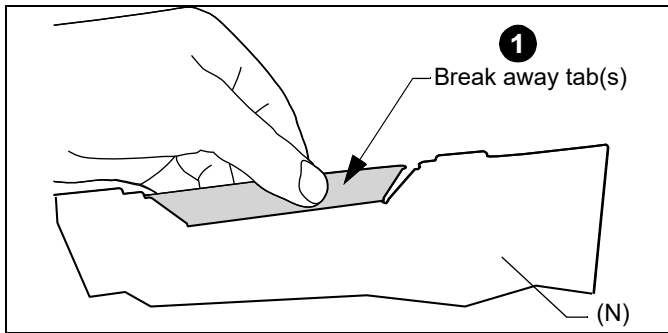

Figure 13

- Gather all wires and route through the cover opening(s). (See Figure 14)
- Install cover (N) and fasten with two #6 x 1-1/4" Phillips self-tapping screws (P) [#6 x 1-1/2" button head self-tapping screws (Q) for security], two spacers (S) and two #6 lock washers (T). (See Figure 14)

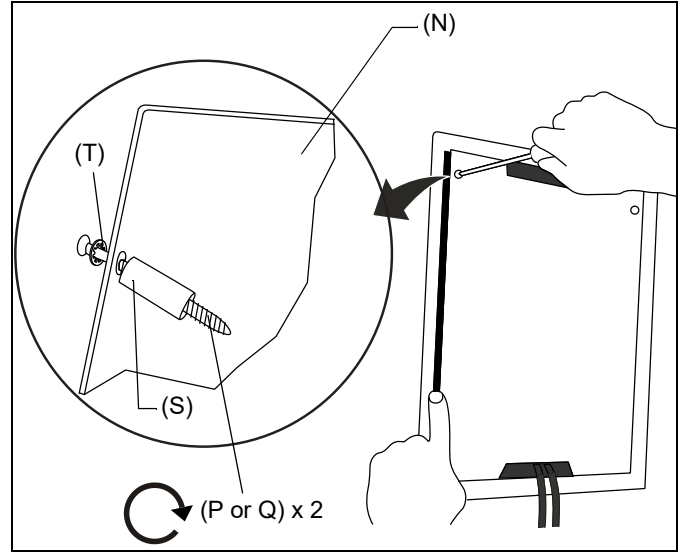

Figure 14

**DIMENSIONS**

RECOMMENDED ELECTRICAL BOX:  
RACO 560 3" X 2" BOX, 2 3/4" DEEP  
GANGABLE OR EQUIVALENT.

RECOMMENDED ELECTRICAL BOX  
COVER: RACO 864 SINGLE DUPLEX

**PAC525**

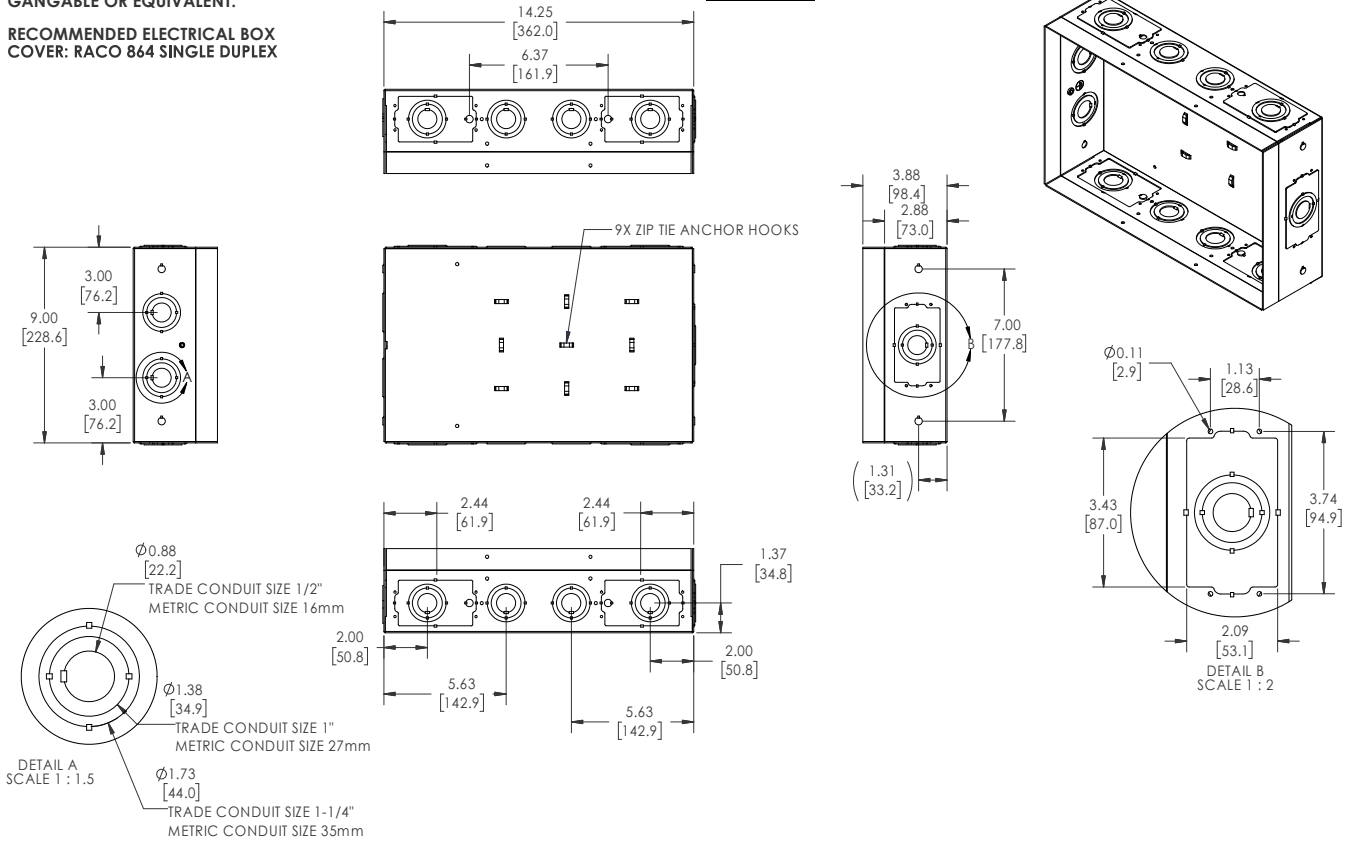

RECOMMENDED ELECTRICAL BOX:  
RACO 560 3" X 2" BOX, 2 3/4" DEEP  
GANGABLE OR EQUIVALENT.

RECOMMENDED ELECTRICAL BOX  
COVER: RACO 864 SINGLE DUPLEX

**PAC525F**

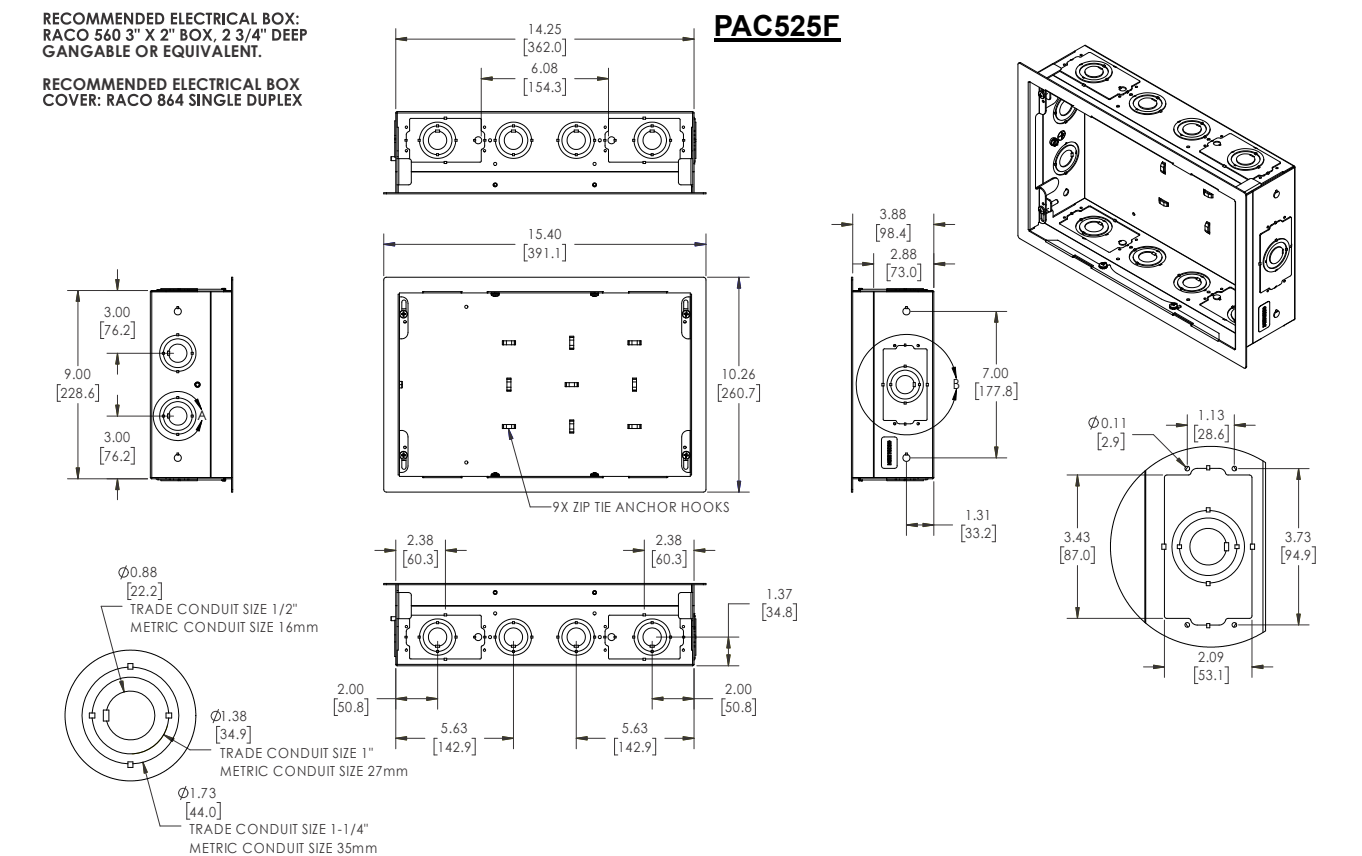

**DIMENSIONS (CONTINUED)**

**PAC525FC**

RECOMMENDED ELECTRICAL BOX:  
RACO 560 3" X 2" BOX, 2 3/4" DEEP  
GANGABLE OR EQUIVALENT.

RECOMMENDED ELECTRICAL BOX  
COVER: RACO 864 SINGLE DUPLEX

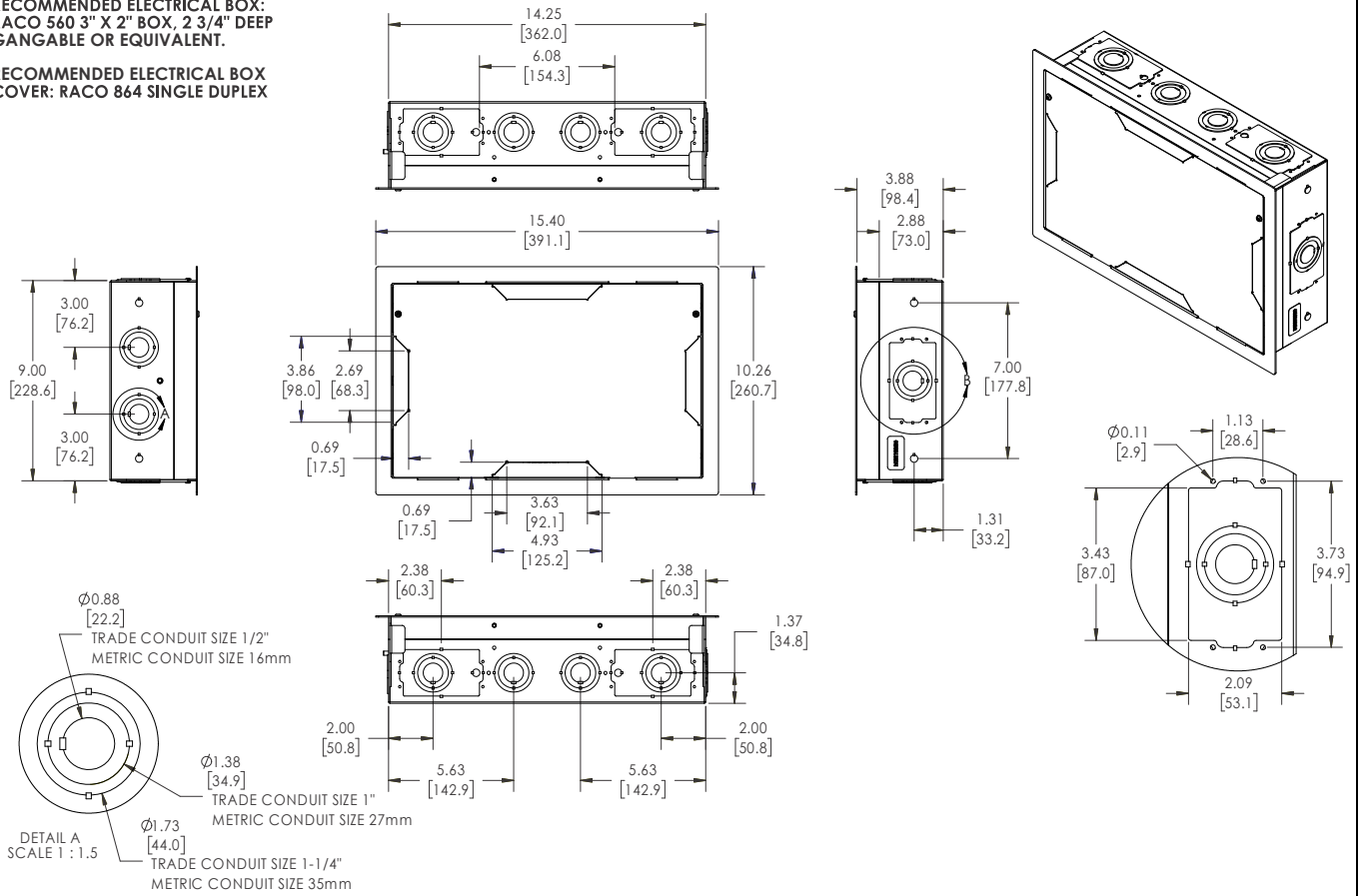

**PAC525F-KIT**

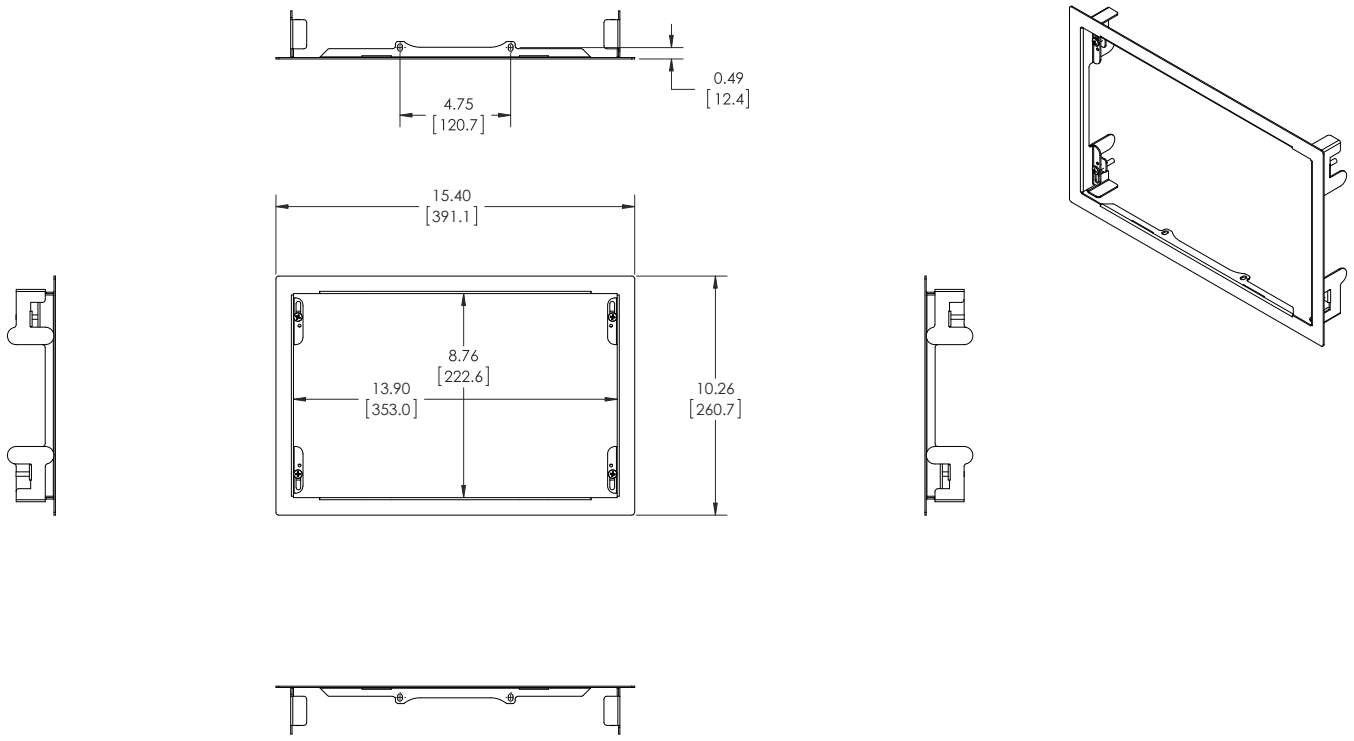

**DIMENSIONS (CONTINUED)**

**PAC525CVR-KIT**

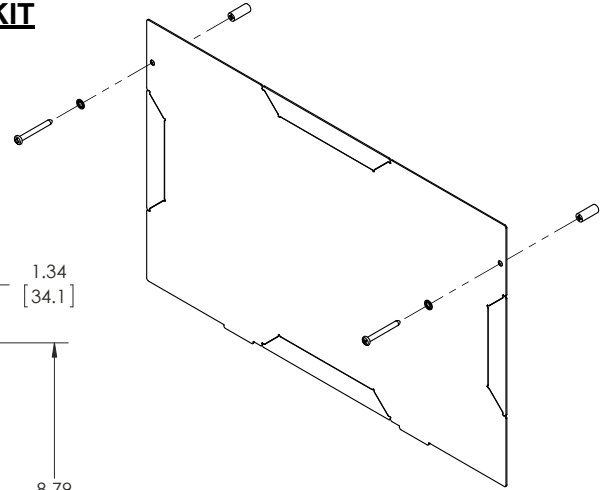
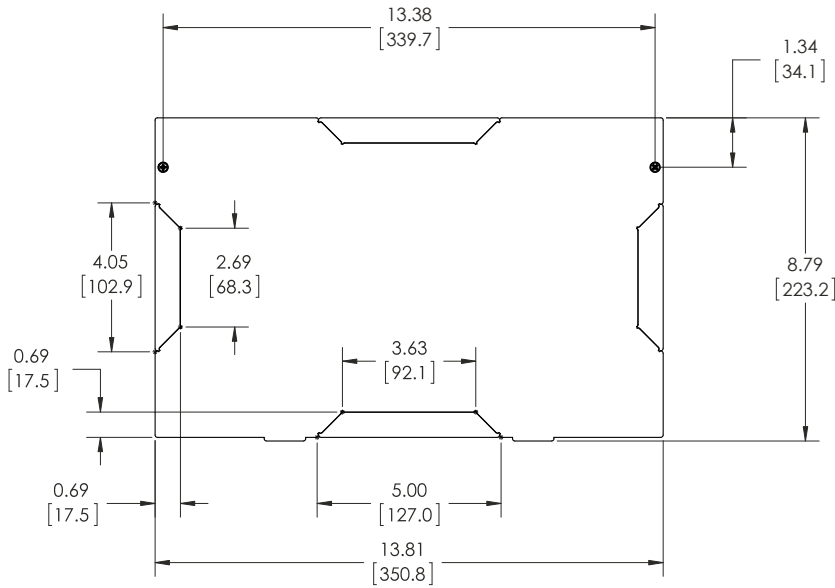

**PAC526**

RECOMMENDED ELECTRICAL BOX:  
RACO 560 3" X 2" BOX, 2 3/4" DEEP  
GANGABLE OR EQUIVALENT.

RECOMMENDED ELECTRICAL BOX  
COVER: RACO 864 SINGLE DUPLEX

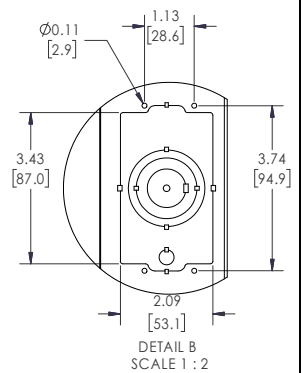
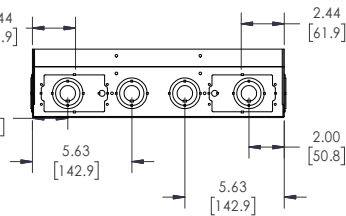
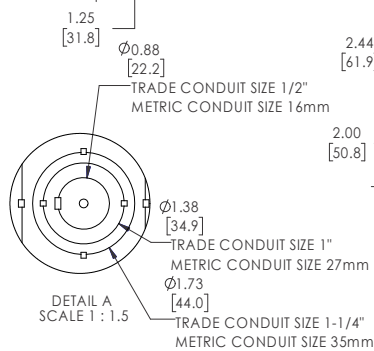
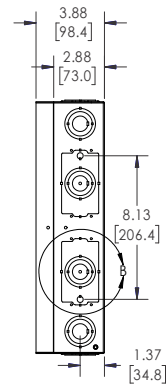
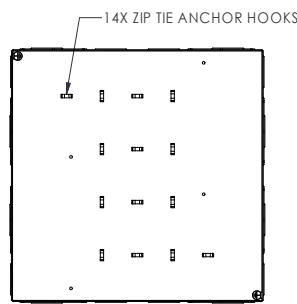
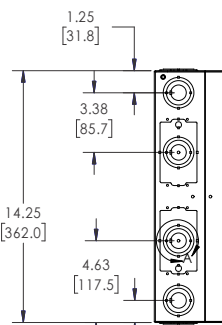
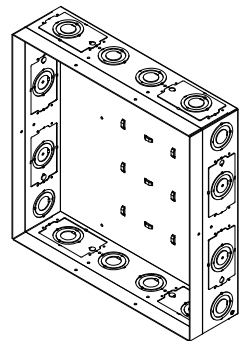
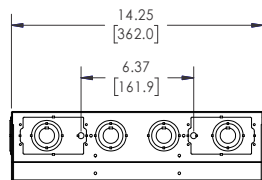

**DIMENSIONS (CONTINUED)**

RECOMMENDED ELECTRICAL BOX:  
RACO 560 3" X 2" BOX, 2 3/4" DEEP  
GANGABLE OR EQUIVALENT.

RECOMMENDED ELECTRICAL BOX  
COVER: RACO 864 SINGLE DUPLEX

**PAC526F**

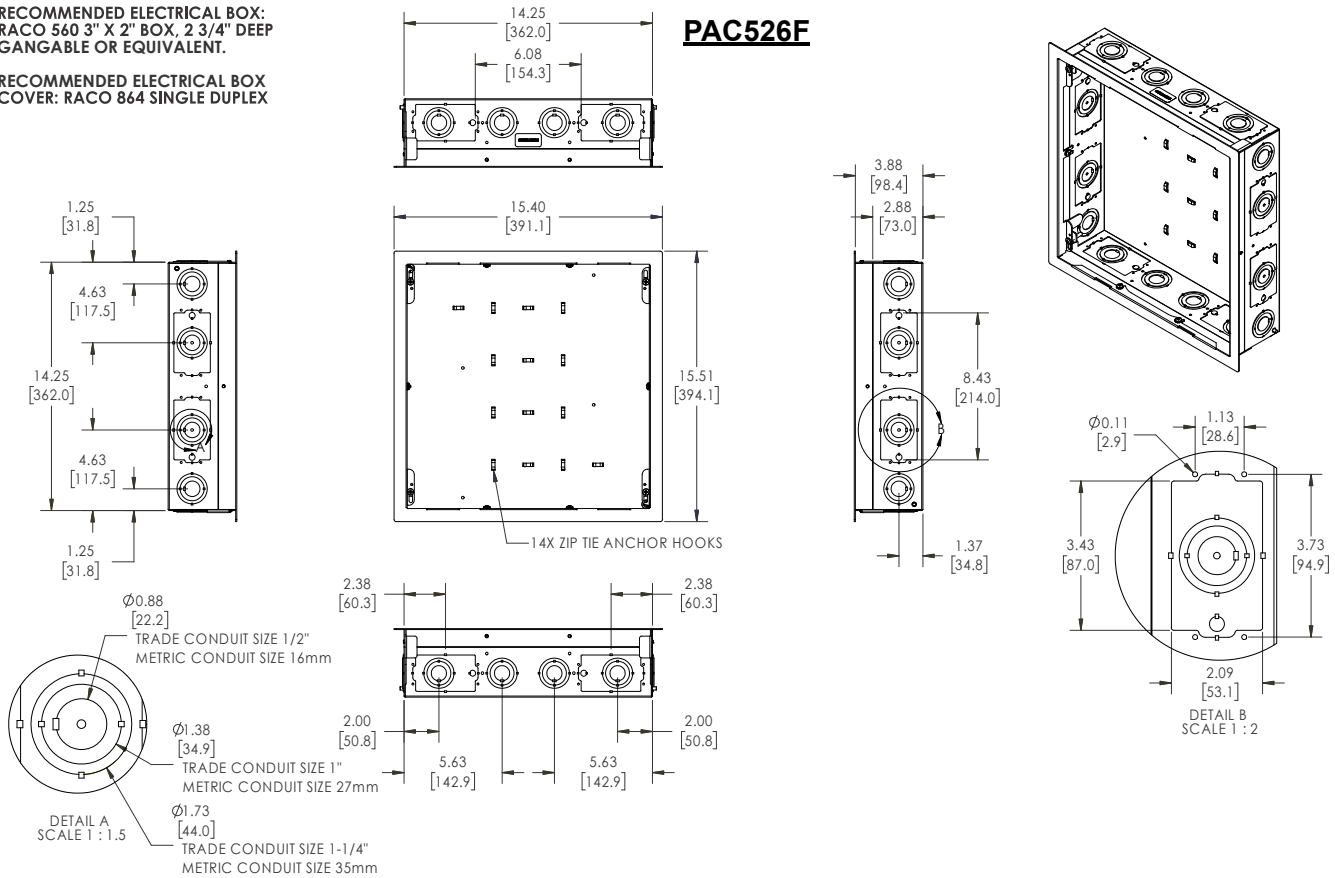

RECOMMENDED ELECTRICAL BOX:  
RACO 560 3" X 2" BOX, 2 3/4" DEEP  
GANGABLE OR EQUIVALENT.

RECOMMENDED ELECTRICAL BOX  
COVER: RACO 864 SINGLE DUPLEX

**PAC526FC**

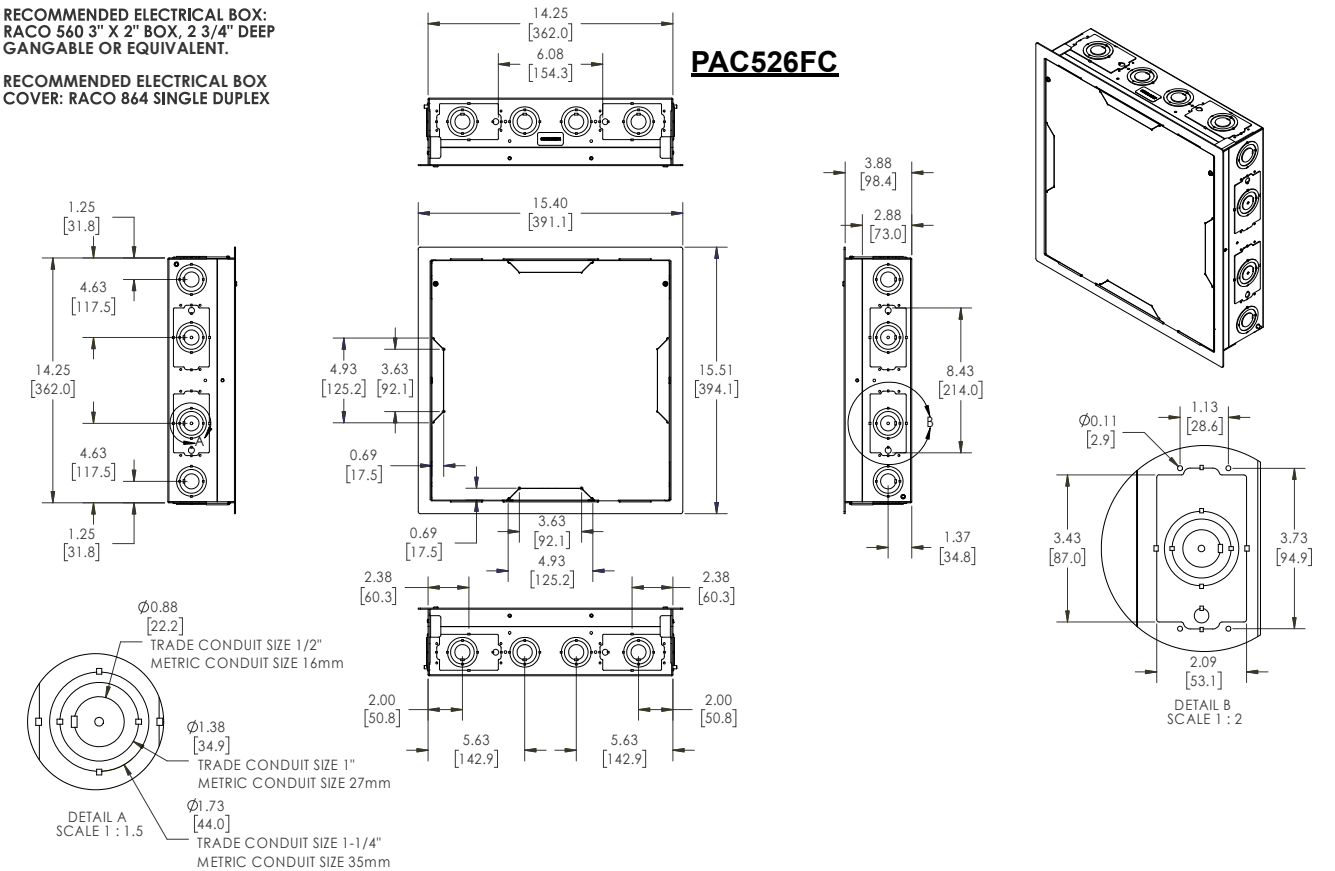

**DIMENSIONS (CONTINUED)**

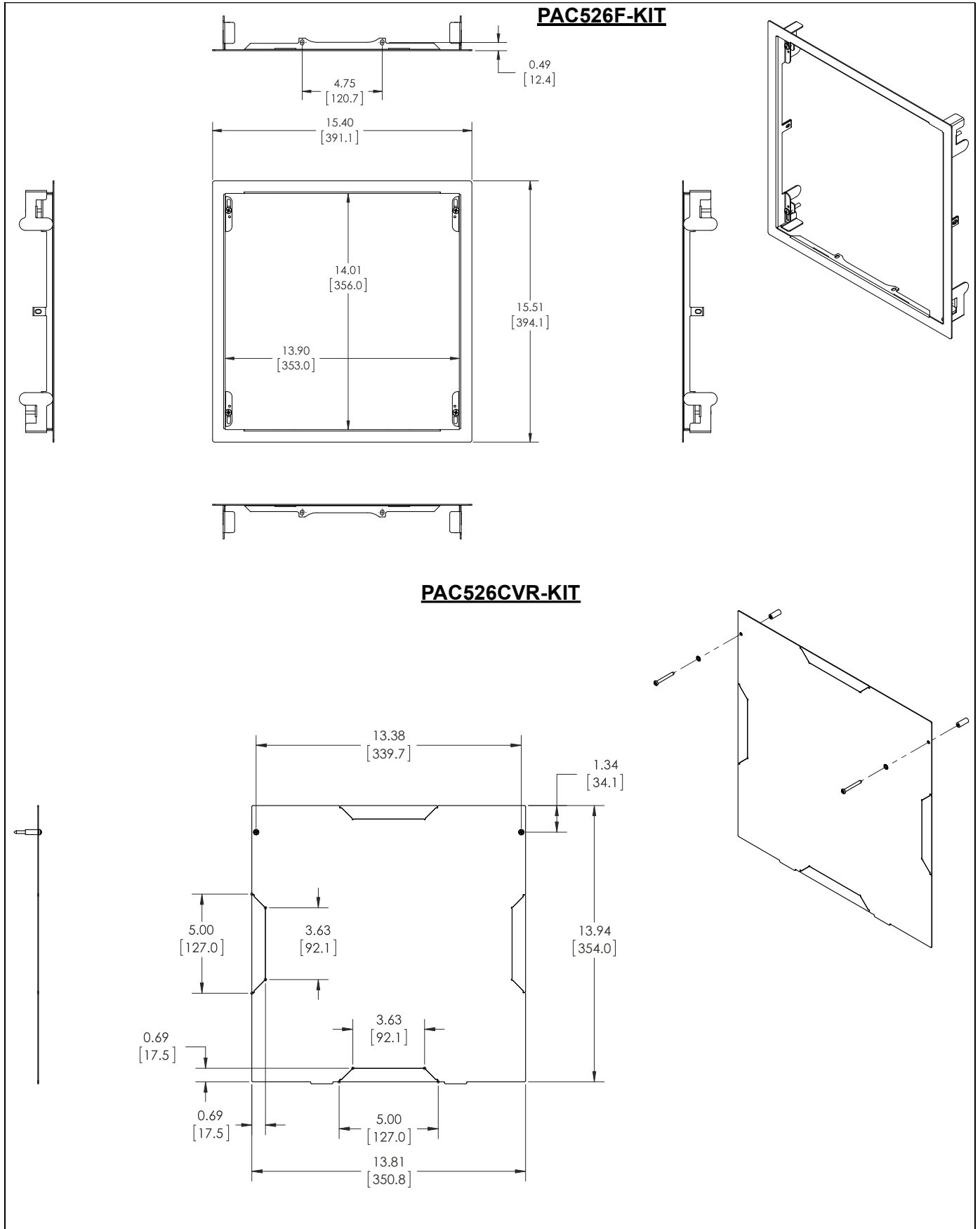

# CHIEF®

A brand of  **legrand**

8800-003252 Rev02  
©2026 Legrand | AV  
[www.legrandav.com](http://www.legrandav.com)  
03/2026

<b>USA/International</b>	<b>A</b> 10900 Red Circle Drive, Minnetonka, MN 55343 <b>P</b> 800.582.6480 / 952.225.6000 <b>F</b> 877.894.6918 / 952.894.6918
<b>Europe</b>	<b>A</b> Franklinstraat 14, 6003 DK Weert, Netherlands <b>P</b> +31 (0) 495 580 852 <b>F</b> +31 (0) 495 580 845
<b>Asia Pacific</b>	<b>A</b> Office No. 918 on 9/F, Shatin Galleria 18-24 Shan Mei Street Fotan, Shatin, Hong Kong <b>P</b> 852 2145 4099 <b>F</b> 852 2145 4477

