

INSTALLATION INSTRUCTIONS

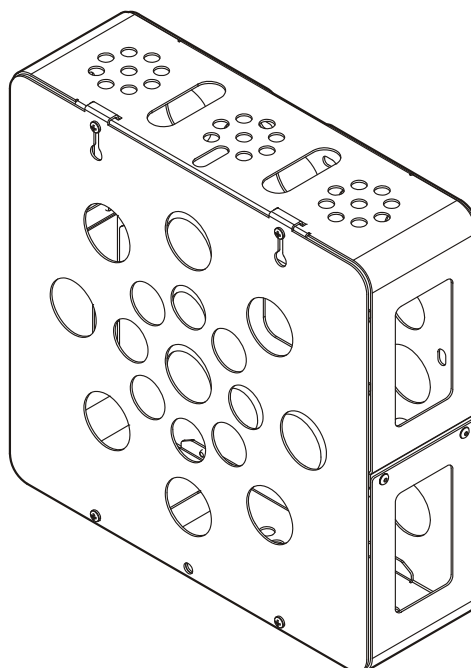
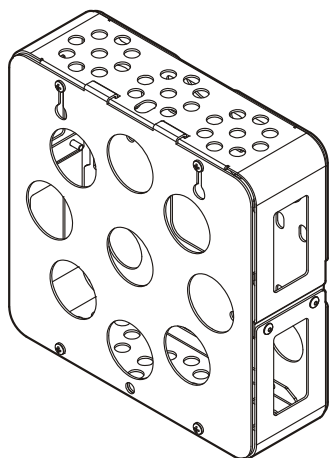

Small/Medium Media Player Enclosures

DISCLAIMER

Legrand | AV and its affiliated corporations and subsidiaries (collectively “Legrand | AV”), intend to make this manual accurate and complete. However, Legrand | AV makes no claim that the information contained herein covers all details, conditions or variations, nor does it provide for every possible contingency in connection with the installation or use of this product. The information contained in this document is subject to change without notice or obligation of any kind. Legrand | AV makes no representation of warranty, expressed or implied, regarding the information contained herein. Legrand | AV assumes no responsibility for accuracy, completeness or sufficiency of the information contained in this document.

Chief® is a registered trademark of Legrand AV Inc.

DEFINITIONS

MOUNTING SYSTEM: A MOUNTING SYSTEM is the primary Chief product to which an accessory and/or component is attached.

ACCESSORY: AN ACCESSORY is the secondary Chief product which is attached to a primary Chief product, and may have a component attached or setting on it.

COMPONENT: A COMPONENT is an audiovisual item designed to be attached or resting on an accessory or mounting system such as a video camera, CPU, screen, display, projector, etc.

WARNING: A WARNING alerts you to the possibility of serious injury or death if you do not follow the instructions.

CAUTION: A CAUTION alerts you to the possibility of damage or destruction of equipment if you do not follow the corresponding instructions.

IMPORTANT SAFETY INSTRUCTIONS

WARNING: Failure to read, thoroughly understand, and follow all instructions can result in serious personal injury, damage to equipment, or voiding of factory warranty! It is the installer’s responsibility to make sure all accessories are properly assembled and installed using the instructions provided.

WARNING: Exceeding the weight capacity can result in serious personal injury or damage to equipment! It is the installer’s responsibility to make sure the combined weight of all components located within the mounting system of the FCA510/FCA515 does not exceed 20 lbs (9.1 kg).

WARNING: Use of this accessory will decrease the weight capacity of the mounting system to which it is attached by the combined weight of the accessory and all components supported by this accessory. See Figure below for reference.

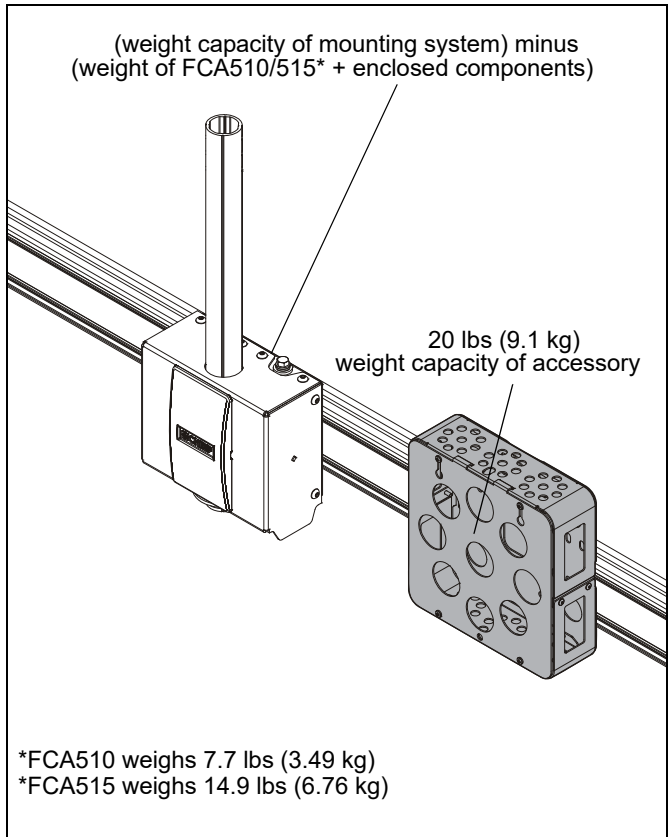

WARNING: Use this accessory only for its intended use as described in these instructions. Do not use attachments not recommended by the manufacturer.

WARNING: Never operate this accessory if it is damaged. Return the accessory to a service center for examination and repair.

WARNING: Do not use this product outdoors.





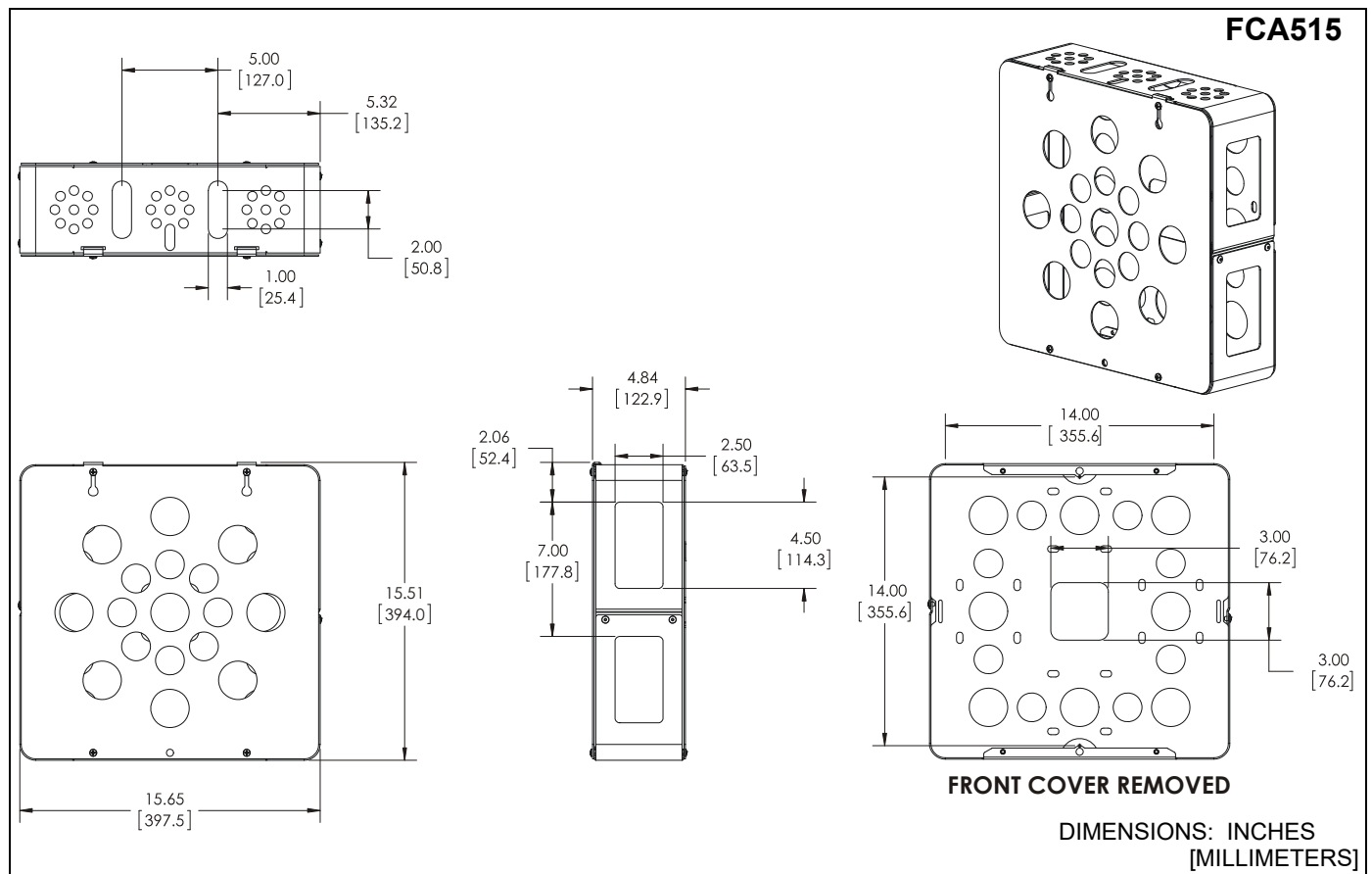
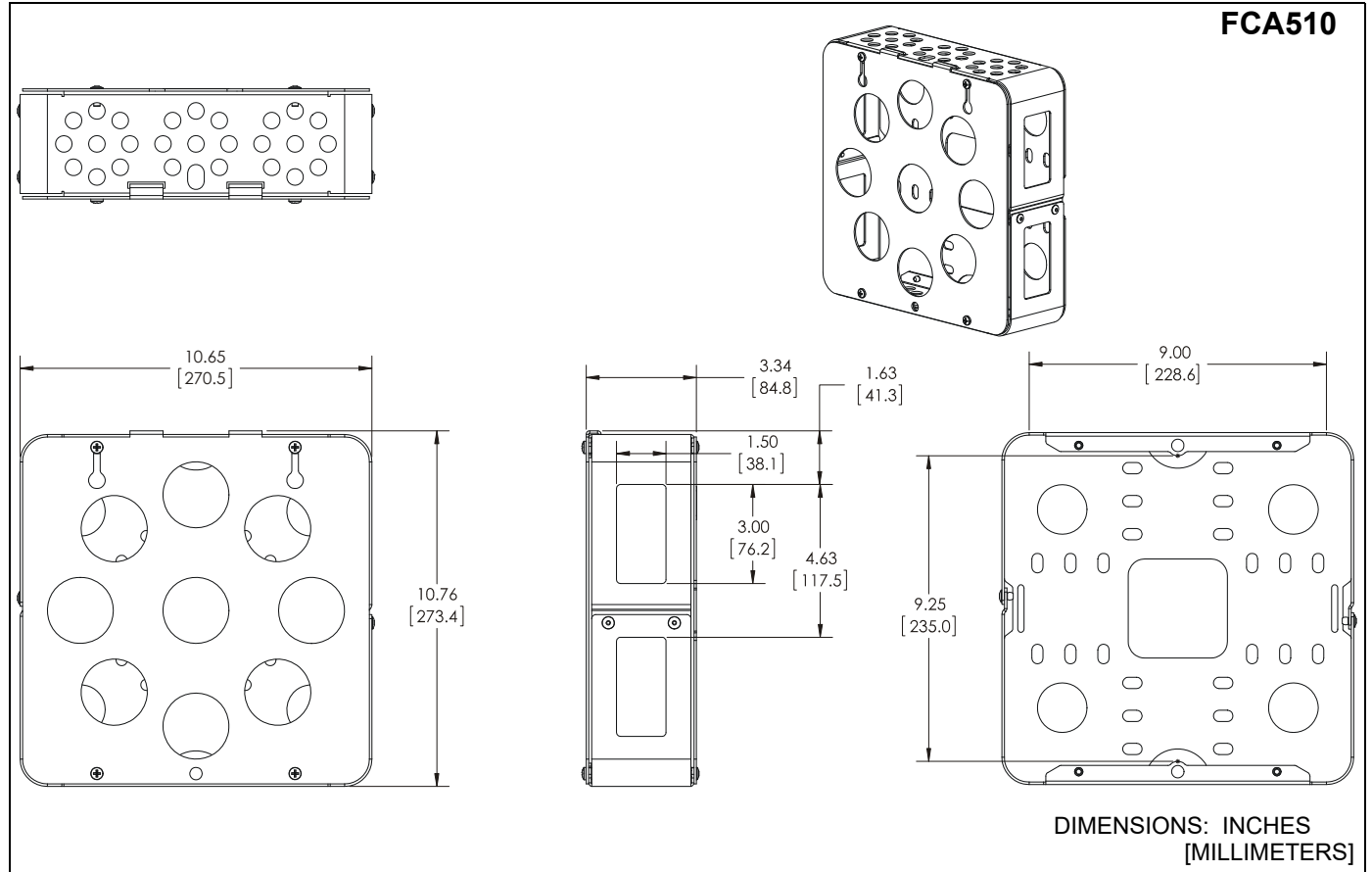

WARNING: RISK OF INJURY TO PERSONS! Do not place video equipment such as televisions or computer monitors on the FCA510 or FCA515.

--SAVE THESE INSTRUCTIONS--

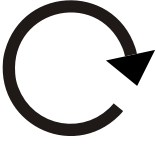
DIMENSIONS

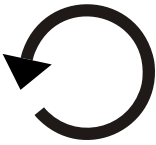

LEGEND

	<p>Tighten Fastener Apretar elemento de fijación Befestigungsteil festziehen Apertar fixador Serrare il fissaggio Bevestiging vastdraaien Serrez les fixations</p>		<p>Hex-Head Wrench Llave de cabeza hexagonal Sechskantschlüssel Chave de cabeça sextavada Chiave esagonale Zeskantsleutel Clé à tête hexagonale</p>
	<p>Loosen Fastener Aflojar elemento de fijación Befestigungsteil lösen Desapertar fixador Allentare il fissaggio Bevestiging losdraaien Desserrez les fixations</p>		<p>Open-Ended Wrench Llave de boca Gabelschlüssel Chave de bocas Chiave a punte aperte Steeksleutel Clé à fourche</p>
	<p>Phillips Screwdriver Destornillador Phillips Kreuzschlitzschraubendreher Chave de fendas Phillips Cacciavite a stella Kruiskopschroevendraaier Tournevis à pointe cruciforme</p>		<p>Socket Wrench Llave de cubo Steckschlüssel Chave de caixa Chiave a brugola Dopsleutel Clé à douilles</p>

TOOLS REQUIRED FOR INSTALLATION

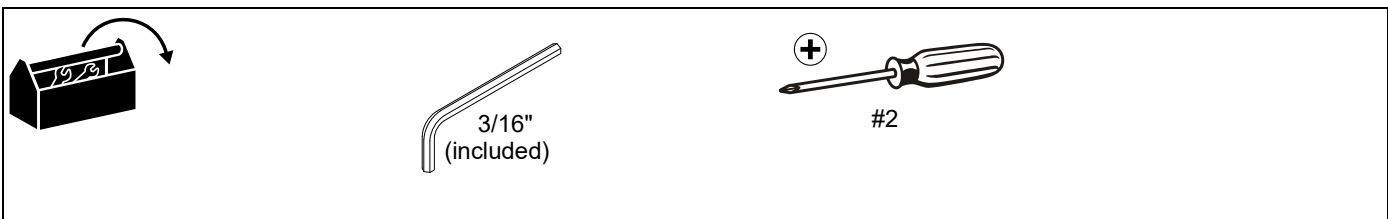

PARTS

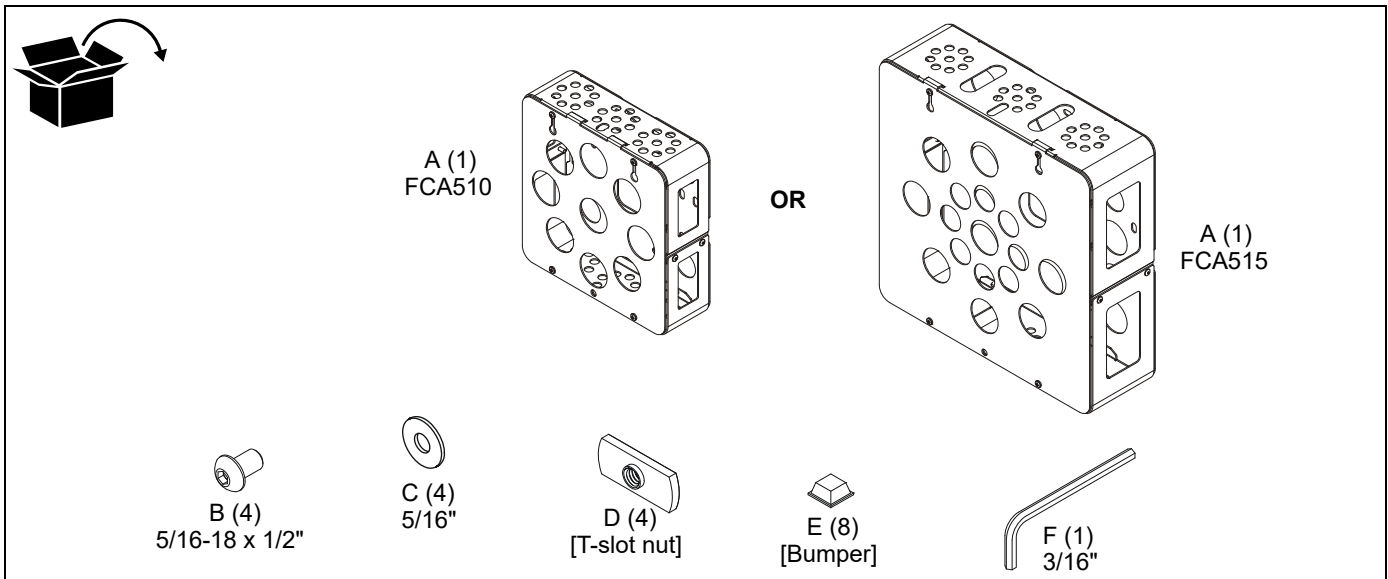

INSTALLATION

NOTE: The FCA510 and FCA515 are compatible with the Chief ceiling mounts and LPE1U, and may be installed in a vertical or horizontal orientation.

Preparing for Installation

1. Remove two Phillips screws from base of FCA510/FCA515 (A). (See Figure 1)
2. Loosen, but do not remove, two Phillips screws at top of FCA510/FCA515 (A).
3. Lift up enclosure door and remove from enclosure. (See Figure 1)

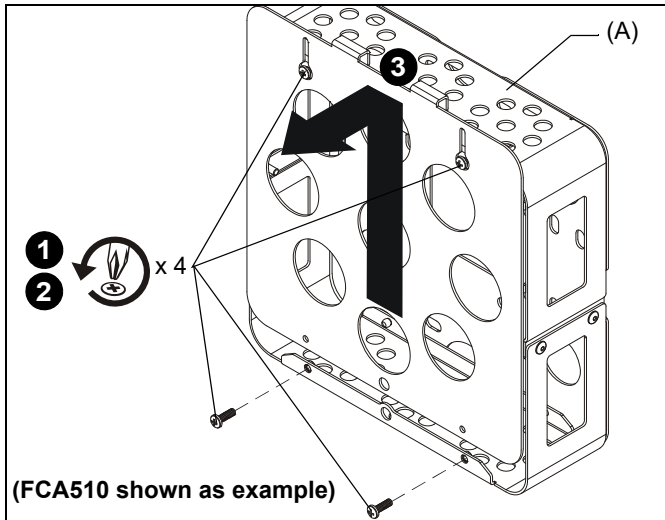

Figure 1

4. Add rubber bumpers (E) to inside of enclosure (A). (See Figure 2)

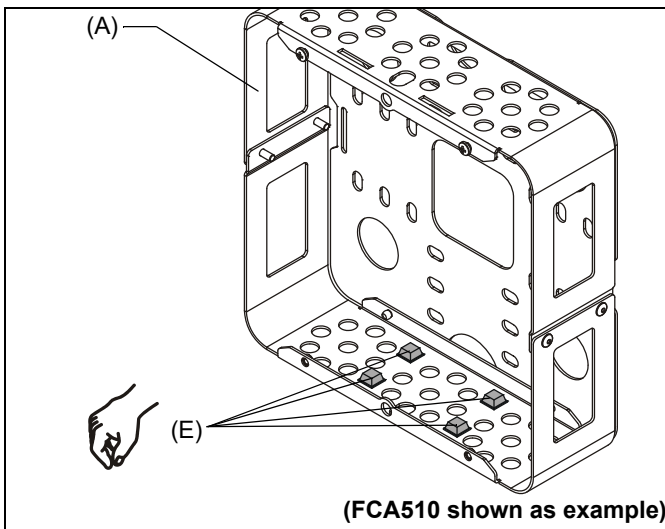

Figure 2

NOTE: Proceed to **Attaching to Mounting Rail**, **Attaching to Ceiling Mount** or **Attaching to LPE1U** section.

Attaching to Mounting Rail

1. If end caps are already in place on the mounting rail, remove two Phillips screws from end cap on one end of mounting rail. (See Figure 3)
2. Remove end cap from one end of mounting rail. (See Figure 3)

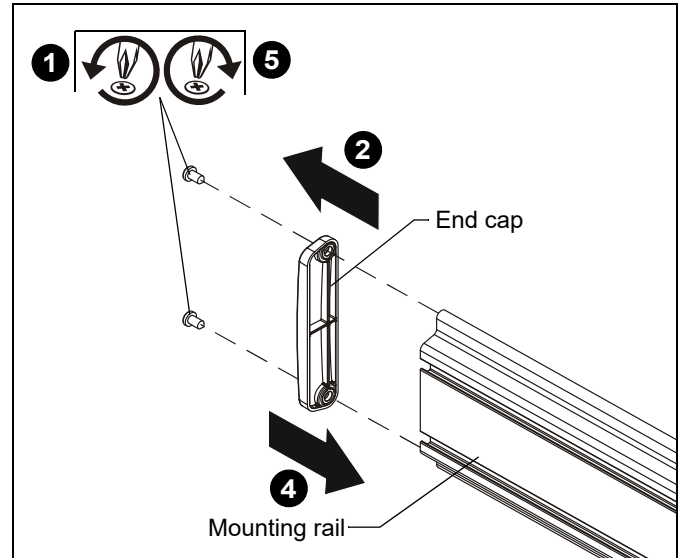

Figure 3

3. Insert four 5/16" T-slot nuts (D) into slots in mounting rail. (See Figure 4)

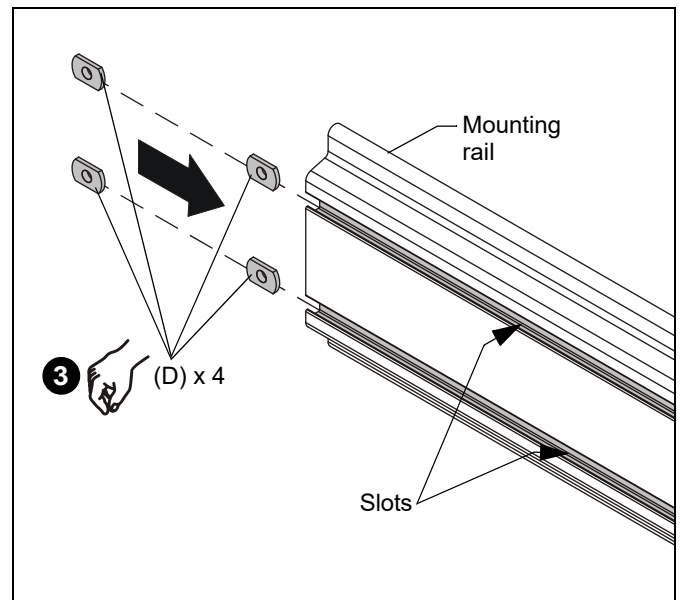

Figure 4

4. Replace end cap on end of mounting rail. (See Figure 3)
5. Fasten with two Phillips head screws removed in Step 1. (See Figure 3)

- Attach FCA510/FCA515 (A) to T-slot nuts (D) using four 5/16-18 x 1/2" button head screws (B) and four 5/16" flat washers (C) into installed T-slot nuts (D). (See Figure 5)

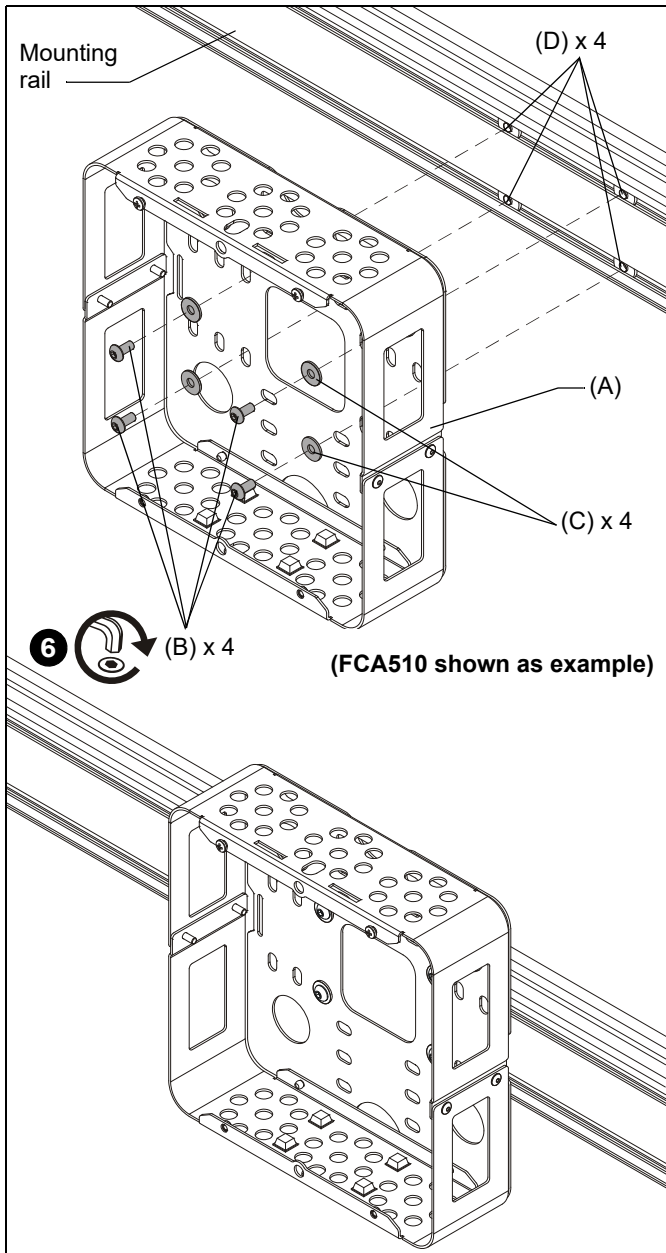

Figure 5

NOTE: The FCA510/FCA515 may be installed with the enclosure door opening in either a horizontal or vertical direction, and may be attached using various attachment points on the FCA510/FCA515. (See Figure 6)

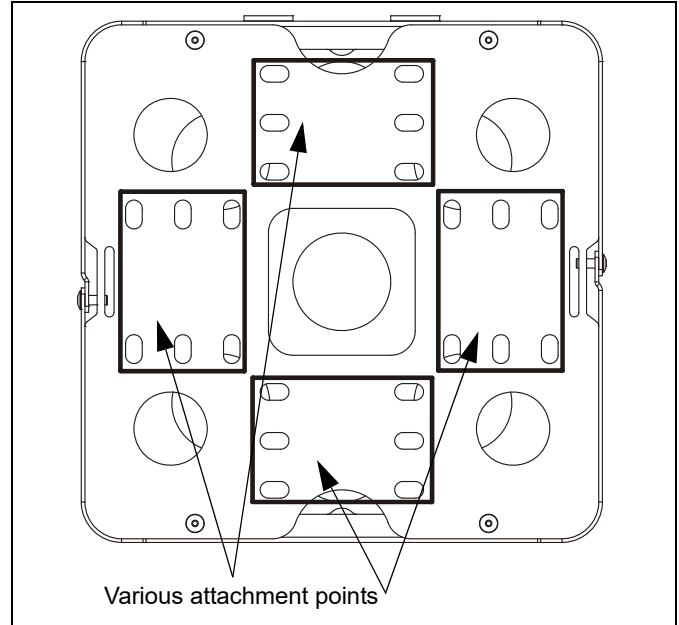

Figure 6

- Proceed to **Installing Media Player** section.

Attaching to Ceiling Mount

- Remove back cover from back of ceiling mount. (See Figure 10)

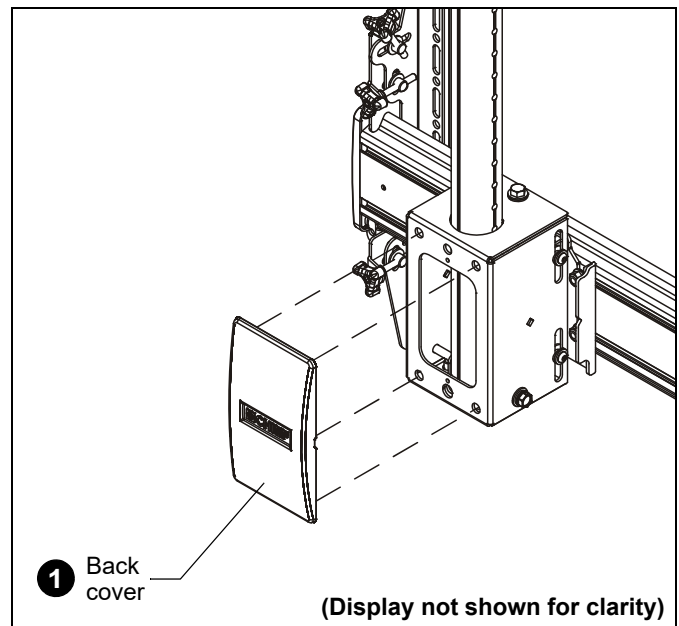

Figure 7

- Attach FCA510/FCA515 (A) to back of ceiling mount using four 5/16-18 x 1/2" button head screws (B) and four 5/16" flat washers (C) installed into back of ceiling mount. (See Figure 8)

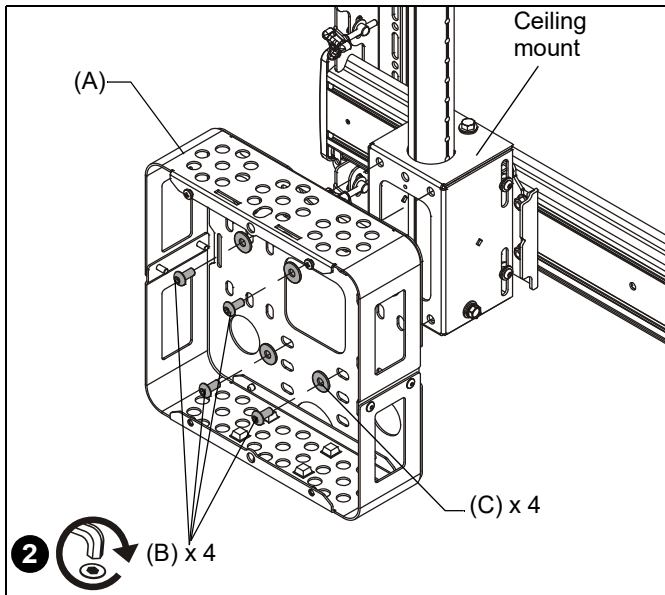

Figure 8

- Proceed to **Installing Media Player** section.

Attaching to LPE1U

- Attach FCA510/FCA515 (A) to LPE1U column using two 5/16-18 x 1/2" button head screws (B) along with two 5/16" flat washers (C). (See Figure 9)

IMPORTANT ! : Ensure that the display attached to the LPE1U does not interfere with the FCA510/FCA515 holder when the display is at its lowest position.

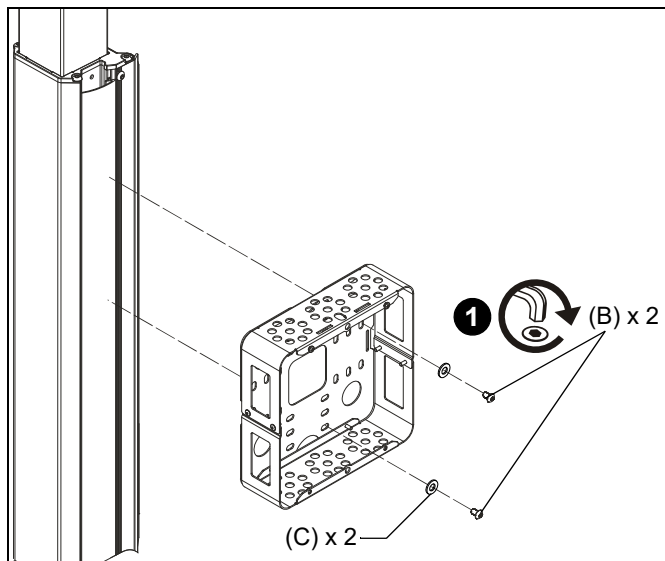

Figure 9

Installing Media Player

- Place media player into FCA510/FCA515 onto rubber bumpers.
- Replace enclosure door on front of the FCA510/FCA515 by inserting door tabs into top of enclosure and lowering top of door over loosened Phillips screws. (See Figure 10)
- Install two Phillips screws removed in Step 1 through lower part of door and into the enclosure base. (See Figure 10)
- Tighten two Phillips screws at top of enclosure.

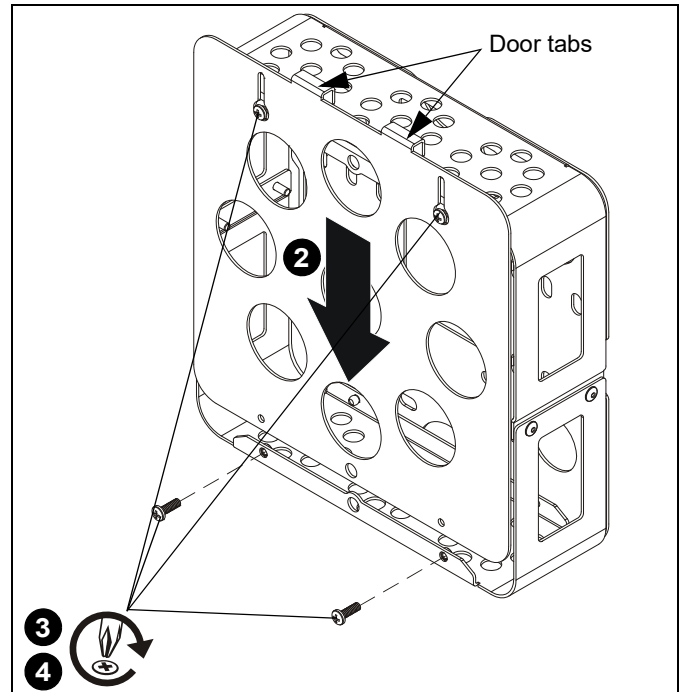

Figure 10

- OPTIONAL:** A padlock (not included) may be added to secure the FCA510/FCA515. (See Figure 11)

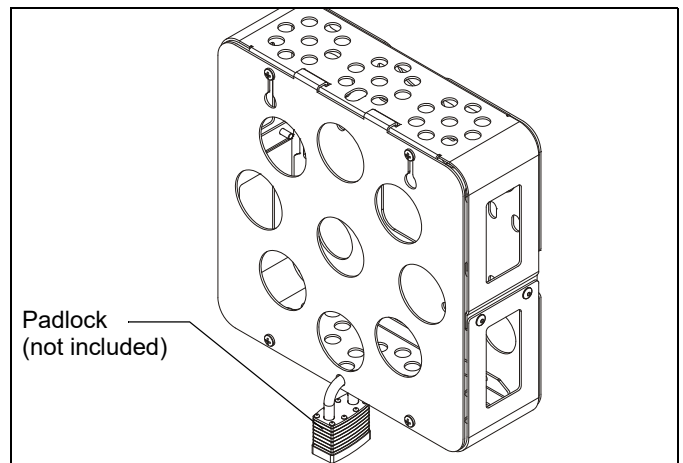

Figure 11



A brand of  **legrand**

8800-002264 Rev02
©2020 Legrand | AV
www.legrandav.com
07/2020

USA/International	A 6436 City West Parkway, Eden Prairie, MN 55344 P 800.582.6480 / 952.225.6000 F 877.894.6918 / 952.894.6918
Europe	A Franklinstraat 14, 6003 DK Weert, Netherlands P +31 (0) 495 580 852 F +31 (0) 495 580 845
Asia Pacific	A Office No. 918 on 9/F, Shatin Galleria 18-24 Shan Mei Street Fotan, Shatin, Hong Kong P 852 2145 4099 F 852 2145 4477

