

# **HPE MSA Gen7 virtual storage—technical reference guide**

# Contents

Executive summary .....	3
Intended audience .....	3
System basics.....	3
Controller architecture.....	4
Controller cache .....	5
SAS .....	6
Virtual storage .....	7
Controllers and pools.....	7
Automated tiering .....	10
Tier affinity.....	16
SSD read cache.....	17
Virtual disk groups and wide striping .....	18
MSA-DP+ disk groups.....	21
Sequential write optimization .....	26
Capacity and performance expansion .....	28
SSD drive endurance .....	31
Thin provisioning.....	33
Thin rebuilds.....	33
Licensing .....	33
Data protection.....	34
Snapshots .....	34
Conclusion.....	35
References.....	35

## Executive summary

This technical paper is an investigation into virtual storage as implemented on HPE MSA Gen7 Storage systems. It also explores the automated tiering engine, as well as supporting technologies of HPE MSA Gen7 Storage arrays. This paper can assist in the creation and implementation of ideal configurations that meet design expectations and reduce the possibility of undesired outcomes. The HPE MSA Gen7 Storage portfolio includes the HPE MSA 2070 and HPE MSA 2072 SAN and SAS storage arrays.

This document is not a user guide and does not list all features or explain how to configure them. For detailed information regarding the features of an HPE MSA Gen7 Storage array, use the links on the last page of this document to reach the core documentation.

### Intended audience

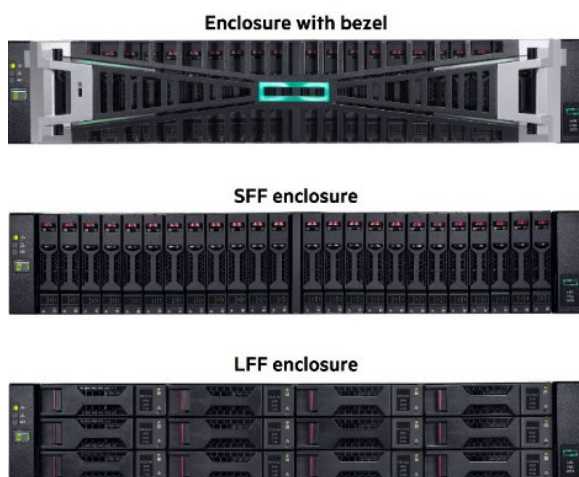
This paper is for everyone involved in the design and implementation of storage solutions that include HPE MSA Gen7 Storage arrays. Technical sales staff tasked with designing an effective solution can benefit from an understanding of the HPE MSA Storage architecture, and as a customer-installable product, so too can a system. Hewlett Packard Enterprise recommends a current knowledge of basic storage concepts such as RAID, mechanical and solid-state drive (SSD) technologies, thin provisioning, and storage networking.

## System basics

The design approach of an HPE MSA Storage array features an active-active architecture that provides both flexibility and resiliency to failure. It ships in a rack-mountable 2U form factor that contains:

- Disk drive bays (either 24x SFF<sup>1</sup> or 12x LFF<sup>2</sup>)
- Two hot-swappable power supply units, each with integrated cooling fans
- Two hot-swappable controller units
- A passive midplane to which all components are connected
- Optional lockable bezel

HPE MSA arrays contain either SAN or SAS controller modules and support optional expansion disk enclosures that house additional disk drives. Expansion disk enclosures include I/O modules in place of controller modules that provide SAS connectivity between disk drives and controller units.



**Figure 1.** HPE MSA enclosures

<sup>1</sup> Small form factor 2.5"

<sup>2</sup> Large form factor 3.5"

HPE MSA 2070 and HPE MSA 2072 arrays support up to nine expansion disk enclosures. HPE MSA 2070 arrays support a mix of up to 120 LFF drives or 240 SFF drives and HPE MSA 2072 arrays support a mix of up to 108 LFF drives and 240 SFF drives.

**Important**

HPE MSA Gen7 Storage arrays support disk enclosures, drives, and transceivers from HPE MSA Gen6 Storage systems but not earlier generations.

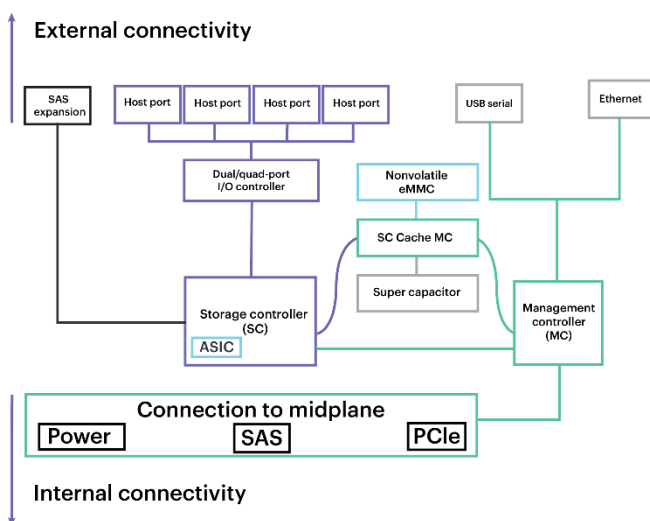


**Figure 2.** HPE MSA array enclosure naming convention

**Controller architecture**

HPE MSA Storage arrays provide full redundancy in the event of a component failure. As shown in Figure 3, in support of availability and performance, each HPE MSA array controller contains its own set of hardware, including:

- Host ports (Fibre Channel, iSCSI, or 12 Gb SAS)
- Management interfaces (Ethernet and serial over USB)
- Storage controller
- Management controller
- Memory/cache
- Internal backup power (supercapacitor)
- Nonvolatile embedded memory card (nonremovable)



**Figure 3.** Simplified HPE MSA controller diagram

Each HPE MSA controller is governed by two logical subcontrollers: the storage controller (SC) and the management controller (MC). These controllers are independent of each other and are composed of and connected to numerous subsystems that provide supporting connectivity and features.

The SC is responsible for the physical movement of data as well as maintaining data integrity. The storage controller is composed of SAS controllers and other similar low-level systems and contains an application-specific integrated circuit (ASIC) for RAID functions. The RAID ASIC supports the HPE MSA in maintaining high levels of performance, even when processing complex algorithms, such as those used in RAID 6 and MSA-DP+.

The management controller runs the HPE MSA Storage Management Utility (SMU), which is accessible by using a web browser over HTTP/HTTPS or through the command-line interface (CLI), preferably over SSH. The management controller operates out-of-band to the storage traffic. Additionally, the management controller is responsible for SNMP and other system-to-system communications. To provide fault tolerance, each controller runs an instance of the SMU, and inter-controller communication occurs through a passive midplane so that configuration information is kept current across both controllers.

---

**Note**

The HPE MSA uses stand-alone management IP addresses for each controller.

---

**Controller cache**

Each controller is an interconnected yet self-contained system; each also has an onboard cache. The cache is high-throughput, low-latency volatile memory assigned to several different system functions, as shown in Table 1.

**Table 1.** Assignment of system cache

Purpose	Per controller	System total
<b>Total cache</b>	24 GB	48 GB
<b>Local read</b>	4 GB	8 GB
<b>Local write</b>	4 GB	8 GB
<b>Partner controller mirror—read</b>	4 GB	8 GB
<b>Partner controller mirror—write</b>	4 GB	8 GB
<b>Operating system overhead</b>	8 GB	16 GB

---

**Important**

It is a common misconception that the quantity of controller cache has a direct correlation to total system performance. Although this might be true of some architectures, it is not true of the HPE MSA, which includes an ASIC dedicated to RAID so that the general-purpose CPU is free to process other tasks such as tracking metadata. Reducing the resources required for RAID also reduces the cache needed to accommodate higher workload intensities. To accurately represent an array's sustained performance capabilities, testing by HPE engineering intentionally overwhelms the controller cache to remove misleading and short-lived, cache-bound benefits. These results match mathematical models used for performance estimation by sizing tools to accurately represent the array's performance in a given configuration under a defined workload.

---

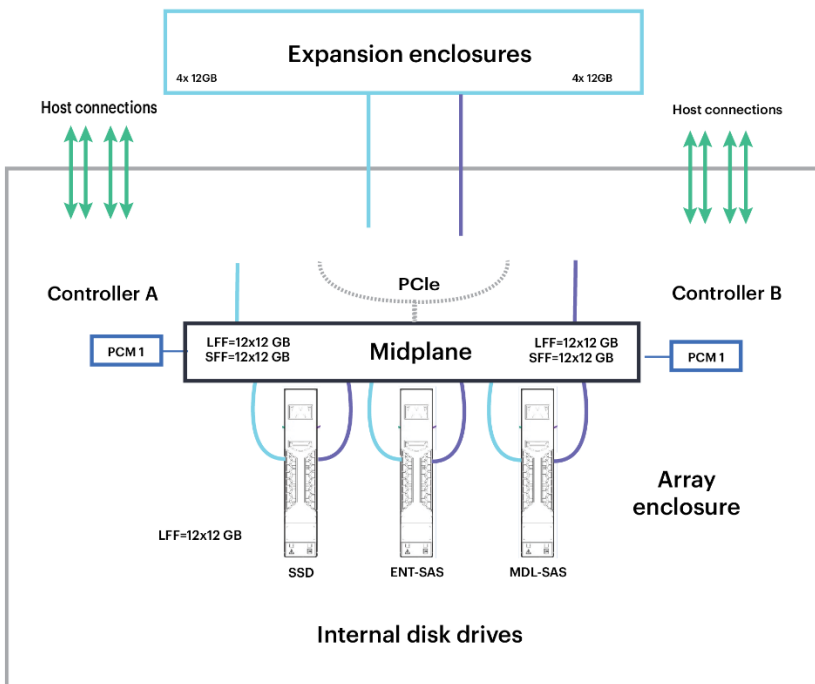
Of the total controller read/write cache, 50% is a mirror of the contents of the partner controller, ensuring that if a controller becomes unavailable, I/O can continue through the remaining controller without data loss.

If the system loses external power, an internal supercapacitor within each controller provides the energy necessary to write the contents of the cache to an embedded, nonvolatile memory card. The restoration of external power flushes the unwritten cache contents to disk.

# SAS

HPE MSA array controllers communicate with all internal drives and connected disk enclosures through 12 Gb SAS. As of December 2024, the HPE MSA is the only HPE array to offer block-based shared storage over the SAS protocol. Although they share the same protocol, external host SAS traffic is entirely separate and unrelated to internal SAS traffic.

As represented in Figure 4, each HPE MSA controller has a single 12 Gb lane dedicated for each internal drive and connects to expansion disk enclosures through a four-lane 12 Gb mini-SAS connection. This architecture provides both high-throughput and redundant paths to drives.



**Figure 4.** HPE MSA array architecture

---

## Important

For optimal performance, locate SSD drives within the array enclosure, which has a dedicated SAS lane for each drive. External enclosures connect to each array controller through two shared four-lane SAS cables

---

## Virtual storage

Virtual storage is the abstraction of underlying storage subsystems to add functionality, increase performance, and simplify the provisioning of volumes. Virtual storage also makes it possible to employ software-driven data services that improve availability and overall efficiency.

In HPE MSA Gen7 Storage arrays, virtualization occurs at two distinct points. The first is at the disk layer in the form of hardware-accelerated RAID, and the second is at the software layer, which pools disk groups together.

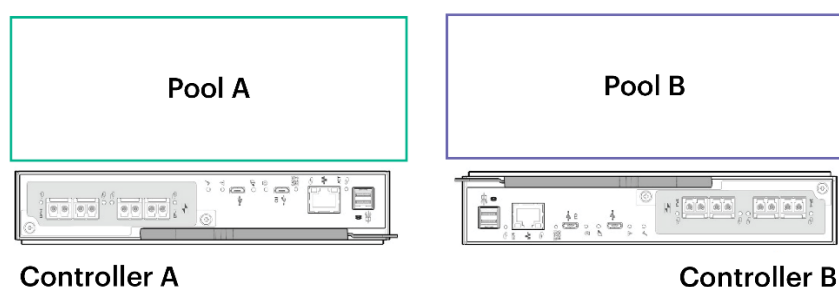
RAID is a type of virtualization that aggregates multiple disk drives into a single object. HPE MSAs used RAID exclusively until firmware GL200 introduced virtual storage for fourth-generation arrays. Fundamentally, RAID increases addressable capacity, performance, and availability for all volumes located within a disk group, although the combination of benefits varies with each RAID level.

Although RAID does an excellent job of tackling these specific goals, it also results in the isolation of these same attributes. That is, volumes do not have access to the capacity and performance of other disks outside their group. Another disadvantage of RAID-only architectures is that it is not possible to increase the capacity or the performance of a disk group without first expanding it with more disks. For small disk groups with low-capacity disk drives, adding more disks might not be a cause for serious concern, but the more disks there are and the larger their capacity, the higher the risk of concurrent drive failures and subsequent data loss. Also, the expansion of a disk group initiates the restriping of existing data, thus impacting performance. Finally, a disk group can only grow to a finite size, which limits application and volume growth to a capacity less than a controller could otherwise support.

Virtual storage still uses these same RAID concepts but improves on them by not only aggregating disks but entire disk groups, thus allowing data to be wide-striped across all disks within a tier. Virtual storage enables an administrator to define the level of redundancy, capacity, and performance that provides appropriate classes of service for volumes within the pool while removing the complexities associated with traditional, RAID-only storage arrays. Additionally, virtual storage offers a mechanism for several advantageous features such as sub-LUN tiering, read cache extension, thin provisioning, fast drive rebuilds, and space-efficient redirect on write snapshots to name a few. The benefits of virtual storage also extend to the management interface, where it is possible to carry out more tasks in fewer actions. For example, in addition to the simplification of volume creation, it is also easier to map multiple volumes to multiple hosts, as well as to visually represent array utilization more efficiently.

### Controllers and pools

An HPE MSA array ships with two controllers supporting one pool each. A pool becomes available when the first disk group is assigned to it.



**Figure 5.** HPE MSA controllers and pools

---

**Note**

HPE MSA Storage arrays are sold in dual-controller configurations only. Although an HPE MSA array can operate in a degraded state with a single controller, it introduces a single point of failure.

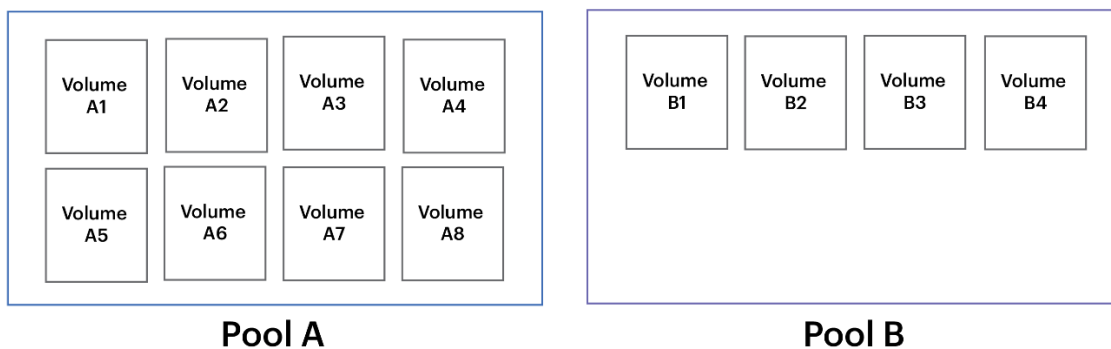
---

**Important**

HPE does not sell seventh-generation controllers outside of an array enclosure except as spares for failed controllers and moving between protocols by replacing controllers is not supported.

---

As shown in Figure 6, a pool is the location of volume data. Because each controller **owns** a specific pool, a volume cannot span or otherwise use the capacity and performance of the other controller. Therefore, it is reasonable to consider each pool as an entirely independent resource. Nevertheless, each pool is accessible through the host ports of its partner controller through the unified LUN presentation (ULP) mechanism. In the event of a firmware update or controller failure, a pool remains online while the remaining controller takes temporary ownership of its disk resources.



**Figure 6.** Relationship between volume and pools

It is supported and potentially advantageous to provision only one pool because this method allows a reduced impact to performance during a firmware upgrade or controller failure. For example, if the potential of a controller is 300,000 IOPS,<sup>3</sup> then two controllers working at the same time could deliver 600,000 IOPS, which is the array's total potential. When a controller becomes unavailable, the potential of the array drops to 300,000 IOPS or less.

---

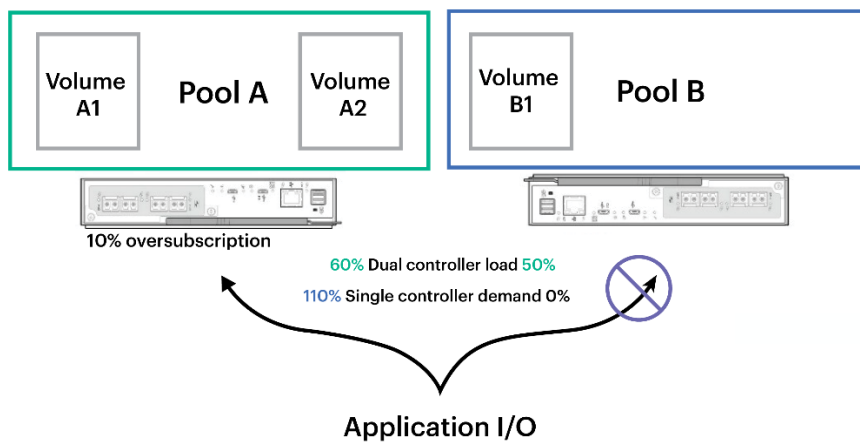
**Important**

If one controller becomes unavailable, the defaults for **controller failure** and **partner notify** force the remaining controller cache policy into write-through mode. The write-through mode can lead to a degradation in write performance in return for the assurance that incoming data is committed to disk, before providing an acknowledgment to the application. Although the full performance of the remaining controller cannot be realized during single-controller operation, it is still important to consider controller headroom as the overall impact to application performance can be minimized. Refer to the HPE MSA 2070 and [HPE MSA 2072 Storage arrays best practices](#) document for further guidance.

---

In the example shown in Figure 7, Controller A has insufficient headroom to absorb the additional workloads temporarily relocated from Controller B. The result is a minor but measurable degradation in overall array performance until the unavailable controller returns to an online state.

<sup>3</sup> This is for example alone. Real performance may be higher or lower and varies due to drive configuration and workloads.



**Figure 7.** Oversubscription of Controller A during the unavailability of Controller B

As an active-active architecture, an HPE MSA supports three approaches when designing a solution regarding headroom:

- **Two pools with no headroom:** Provisioning both pools concurrently with sufficient drive resources allows workloads to consume the full potential of the array in terms of both performance and capacity. This option is sometimes chosen because controller downtime is typically very low, and planned controller firmware upgrades during quiet periods negate any performance impact. Additionally, when configured appropriately, an HPE MSA Gen7 Storage array performs so well that consistent consumption of more than 50% of the potential of the array is uncommon. As a result, there is often sufficient headroom, even if it is not explicitly managed.
- **One pool with 100% headroom:** Provisioning a single pool and placing all workloads in it reduces the impact on performance when a controller becomes unavailable and greatly simplifies configuration management. Because typical requirements for small and medium-sized businesses are far below the capacity and performance limits of a single pool, HPE recommends evaluating a single-pool strategy before considering dual pools. System configuration limits are documented in the [HPE MSA 2070 / HPE MSA 2072 Storage Management Guide](#).
- **Two pools with 100% headroom:** Similar to the second option, this method seeks to facilitate that performance remains predictable during the time a controller is unavailable. This method might also be preferable when capacity beyond what a single pool can provide is required. However, keeping within this headroom after a system is in production can be challenging. For example, as a pool's capacity expands, workloads can grow and consume the additional performance, and therefore, headroom without the administrator realizing it. A common scenario to which a dual pool strategy is best suited is a hybrid configuration where, for example, pool A is configured with SSDs and pool B is configured with MDL-SAS hard disk drives.

---

### Important

When designing a storage solution, it is important to have a detailed understanding of all workloads, as well as the capabilities of the array to avoid undesired outcomes.

---

A pool is a collection of 4 MB pages. The number of pages within a pool depends on the total capacity of all virtual disk groups associated with it. For example, if there were a single disk group with 1 TB of usable capacity, there would be a total of 250,000 4 MB pages ( $1,024,000,000 / 4096 = 250,000$ ). Although the number of pages in a pool can change, the size of the page does not.

Within an HPE MSA, a volume is a collection of pages amounting to a defined capacity. The location of a volume's designated pages within the pool changes over time and is dependent on several factors, such as the use of tiering, snapshots, and thin provisioning. As shown in Figure 8, it is practical to visualize a pool as a grid filled with pages, which may or may not be in order. Each page has a contiguous range of logical block addresses (LBAs) for a volume assigned to it. A page is only associated with one volume.

1 PAGE #1 Volume 'Vol_1' LBA 0 - 4,095	2 PAGE #2 Volume 'Vol_1' LBA 4,096 - 8,191	3 PAGE #3 Volume 'Vol_1' LBA 8,192 - 16,383
1 PAGE #4 Volume 'Vol_2' LBA 0 - 4,095	2 PAGE #5 Volume 'Vol_2' LBA 4,096 - 8,191	4 PAGE #6 Volume 'Vol_1' LBA 16,384 - 32,767
3 PAGE #7 Volume 'Vol_2' LBA 8,192 - 16,383	4 PAGE #8 Volume 'Vol_2' LBA 16,384 - 32,767	5 PAGE #9 Volume 'Vol_1' LBA 32,768 - 65,535

**Figure 8.** Representation of page assignment within a pool

An operating system has no awareness of data locality within the array.

As shown in Figure 9, the operating system lays a file system across what it sees as a physical disk, composed of multiple 512-byte sectors. Applications typically interact with the file system to read and write data, and the data granularity is often coarser than that of the file system. In the example in Figure 9, the HPE MSA reads and writes to a single page for all sectors from #1 through to #8,192.

Host Addressing	32K application block	#1										...	#128		
	4K file-system cluster	#1										...	#8	...	#1,024
	512b logical	#0	#1	#2	#3	#4	#5	#6	#7	...	#64	...	#8,192		
	Disk LBA	#0	#1	#2	#3	#4	#5	#6	#7	...	#63	...	#8,191		
Array Addressing	Volume LBA	#0	#1	#2	#3	#4	#5	#6	#7	...	#63	...	#8,191		
	Pool Location	PAGE #1													

**Figure 9.** Addressing and data unit translation with theoretical application and file system block sizes

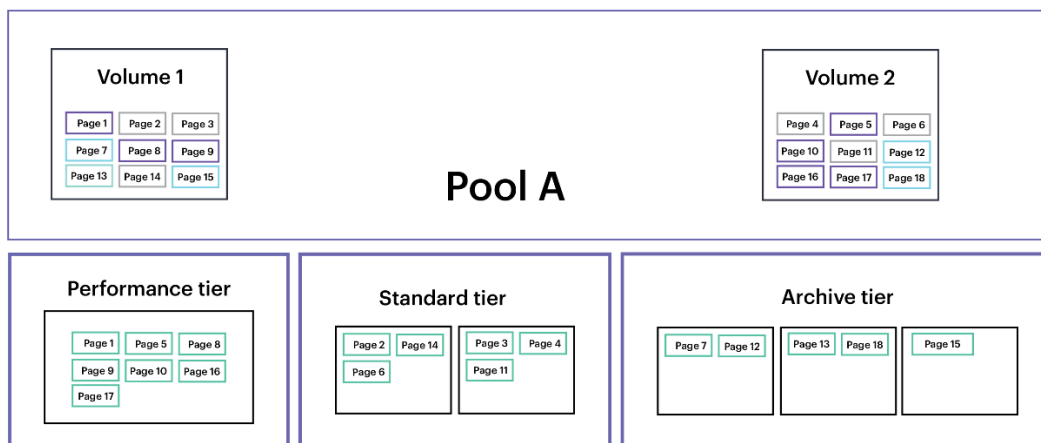
### Automated tiering

A standout capability of virtual storage is automated sub-LUN tiering, which can increase overall system performance at a lower cost than possible with only one class of disk drive. Automated tiering can distribute the contents of a volume over multiple virtual disk groups within a tier as well as over multiple drive classes grouped to form a pool. This process exploits the performance benefits of a particular drive type, but only for the part of a volume that requires it. As shown in Table 2, an HPE MSA supports three tiers of storage; each tier relates to a specific drive class.

**Table 2.** Tiers and disk drive types

HPE MSA tier name	Disk type	Industry term
Performance	SSD	Tier 0
Standard	15K and 10K enterprise SAS hard disk drives (HDDs)	Tier 1
Archive	7.2K MDL SAS HDDs	Tier 2

A tier is specific to a pool and includes all disk groups of a particular drive type associated with that pool. Figure 10 shows how pages of all volumes within a pool are distributed across all three tiers and all six disk groups that are associated with it.<sup>4</sup>



**Figure 10.** Example of volume distribution across multiple tiers within a single pool

Table 3 lists the four ways to configure a pool.

**Table 3.** Pool configurations

Configuration	Layout	Advantages / use cases
<b>Single tier</b>	Single drive class, wide-striping only, and no automated tiering	<ul style="list-style-type: none"> <li>– Great for high capacity and sequential I/O-centric configurations where mixed workloads are rare</li> <li>– Consistent and predictable performance for all volumes</li> </ul>
<b>Performance tiering</b>	Tiering with SSDs. Can be one of two recommended layouts: <ul style="list-style-type: none"> <li>– Two tiers: performance and standard tiers<sup>5</sup></li> <li>– All three tiers</li> </ul>	<ul style="list-style-type: none"> <li>– Hybrid pools are ideal for mixed workloads and a hands-off approach</li> <li>– SSDs count towards usable capacity</li> </ul>
<b>Archive tiering</b>	Standard and archive tiers	Great for high-capacity solutions with relatively low-performance requirements
<b>SSD read cache</b>	SSDs used as an extension to read cache together with either single or archive tiering	Greatly accelerates random reads with a minimum investment and does not require a license

<sup>4</sup> This is for example alone. Actual distribution of pages depends on several factors.

<sup>5</sup> Due to a substantial performance differential, performance tiering between the performance and archive tiers is supported but not considered best practice.

Without automated tiering, a pool would consist of only a single disk drive type and could not grow cost effectively beyond the characteristics of that drive technology. However, a pool with a single tier can be the right choice for many solutions, particularly those requiring exceptional sequential performance and high capacities. As an entry storage array, HPE MSA arrays are typically deployed as a single solution within environments that contain multiple workloads requiring a mix of demanding random I/O and sequential I/O simultaneously.

For all and especially random workloads, flash storage is ideal because it provides an exceptional ratio of cost to performance. However, the cost-to-capacity ratio remains higher than that of mechanical drives. HPE supports configuring an HPE MSA as an all-flash array, which can be a cost-effective solution when a large capacity of low-latency storage is required. However, all-flash configurations are suitable for datasets that are not strong candidates for data reduction through deduplication or compression. For such datasets, there are more suitable products within the HPE portfolio that can provide both a high level of guaranteed random I/O performance and a better ratio of cost to capacity.

Typically, hybrid storage arrays consisting of both SSDs and HDDs are an effective route to achieving improved random and sequential performance without drastically overshooting a capacity goal or budget.

**Table 4.** Methods of increasing application performance

Method	Advantages	Disadvantages
<b>Add more disk drives to a traditional RAID disk group (RAID 10, 5, 6)</b>	<ul style="list-style-type: none"> <li>– Improves performance for a disk group</li> </ul>	<ul style="list-style-type: none"> <li>– Can negatively affect the availability of the disk group and subsequently the pool</li> <li>– Only improves performance for that disk group and a portion of a tier</li> <li>– Consistent performance requires configuring all disk groups equally. Because it is not possible to expand a traditional RAID disk group, the disk group must be removed, resized, and reintroduced to a pool. It also requires sufficient unallocated capacity to be present within the pool to absorb the temporary loss of its capacity</li> <li>– Might be disruptive to application performance</li> <li>– Requires careful planning to implement smoothly</li> </ul>
<b>Add more disk groups to a tier</b>	<ul style="list-style-type: none"> <li>– Can produce measurable performance gains for standard and archive tiers</li> <li>– Does not impact the availability of a pool</li> <li>– Supports incremental growth of capacity and performance</li> <li>– Is the correct approach to meet capacity goals</li> </ul>	<ul style="list-style-type: none"> <li>– It might be necessary to overprovision a pool's capacity to achieve a performance goal, particularly for random I/O</li> <li>– Is potentially more expensive if the capacity goal is less than the sum of all additional drives</li> </ul>
<b>Switch to a more performant drive technology</b>	<ul style="list-style-type: none"> <li>– A guaranteed solution to increase array performance up to the point of the controller or link saturation or drive count limit</li> <li>– Is suitable for uncompromising application requirements</li> </ul>	<ul style="list-style-type: none"> <li>– Can be extremely expensive to reach both capacity and performance goals at the same time</li> <li>– Temporarily invokes tiering unless data is migrated from one pool to another or restored from backup; configuring both SSD and HDD</li> </ul>

drive technologies at the same time requires an HPE MSA Advanced Data Services Suite license<sup>6</sup>

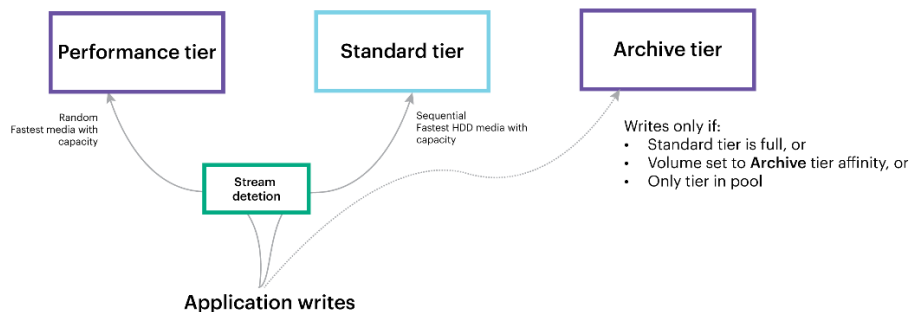
- Might be disruptive, especially if using a backup and restore approach

<b>Automated tiering</b>	<ul style="list-style-type: none"> <li>– Can provide performance benefits for all volumes within a pool</li> <li>– Only a percentage of total capacity uses more expensive drive technology</li> <li>– Is simple to deploy</li> <li>– Can be configured online</li> </ul>	<ul style="list-style-type: none"> <li>– Requires an HPE MSA Advanced Data Services Suite license<sup>7</sup></li> <li>– Can be overwhelmed by intense and sustained workloads</li> </ul>
<b>SSD read cache</b>	<ul style="list-style-type: none"> <li>– Is very cost-effective</li> <li>– Requires only one SSD per pool to get started</li> <li>– Does not require a license</li> <li>– Is well-suited for random read-dominant workloads</li> </ul>	<ul style="list-style-type: none"> <li>– Takes time to warm-up</li> <li>– Does not directly accelerate writes</li> <li>– Does not accelerate sequential access</li> <li>– Is limited to 3.8 TiB per pool, which restricts the pool size when staying within the minimum recommended 10% of the fastest HDD tier</li> </ul>

The HPE MSA automated tiering engine is responsible for ensuring the optimal location for data, including when data is first written to a volume. Some tiering solutions attempt to deliver flash-like performance by writing all inbound data to the fastest drive class within the system. However, such an approach is not as efficient as that of the HPE MSA and presents several problems:

- Migrating data from one location to another requires more back-end I/O to make space for new data.
- Scheduled page migrations require adequate quiet time, so application performance is not impacted.
- Keeping the fastest tier full creates greater contention for hot read data.
- If writes are not separated, disk drive types that are well suited to sequential I/O cannot be taken advantage of.

An HPE MSA solution solves these problems by redirecting inbound writes to an appropriate tier. This approach requires less back-end I/O to relocate pages later and frees capacity within the higher performance tiers for more relevant data. As shown in Figure 11, when performance tiering is used, the engine can detect inbound data streams and direct sequentially written application data to the fastest tier comprising traditional HDDs. Sequential I/O is well suited to mechanical disk drives, whereas random I/O is latency-sensitive and best served by SSDs. Thus, this in-line approach significantly improves overall performance and does not require any administrative intervention. In both scenarios, if the destination tier is full, then the next fastest tier with available capacity is used instead.

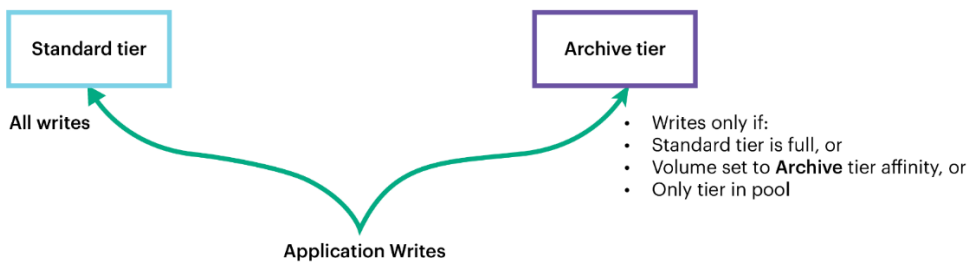


**Figure 11.** Automated redirection of inbound writes when using performance tiering

<sup>6</sup> An HPE MSA Advanced Data Services Suite license comes as standard with HPE MSA 2072 Storage.

<sup>7</sup> An HPE MSA Advanced Data Services Suite license comes as standard with HPE MSA 2072 Storage.

When archive tiering is used, all inbound writes land on the standard tier unless its capacity is exhausted or if a volume has the **Archive tier affinity** setting applied. Refer to the Tier affinity subsection of this paper for more information.



**Figure 12.** Archive tiering write mechanism

Unlike some tiering mechanisms, an HPE MSA does not schedule page migration to occur on a daily or hourly basis. It also does not require a large quantity of expensive low-latency memory or cache to buffer uncoordinated back-end writes. Instead, an HPE MSA tiering engine uses minimal resources, which allows it to relocate pages almost continuously if necessary.

With a frequency of every five seconds, the tiering engine analyzes a pool and promotes or demotes pages according to how in demand they are in a process known as page ranking. Page ranking seeks to keep active data on the fastest drive type within a pool by tracking what pages are accessed frequently within a given time frame.

**Table 5.** Page ranking example

Page rank	Current page	Volume	Direction
<b>First</b>	Page 3	Volume A	Promoted
<b>Second</b>	Page 7	Volume B	Promoted
<b>Third</b>	Page 5	Volume A	Promoted
<b>Fourth</b>	Page 2	Volume A	Promoted
<b>Fifth</b>	Page 1	Volume A	Promoted
<b>Sixth</b>	Page 6	Volume A	Demoted
<b>Seventh</b>	Page 8	Volume B	Demoted
<b>Eighth</b>	Page 9	Volume A	Demoted
<b>Ninth</b>	Page 4	Volume B	Demoted

Another way to think of ranking is as a heat map where frequently accessed pages are hot and infrequently accessed pages are cold. As data cools, it becomes eligible for eviction as needed, to lower-performing and less-costly tiers.

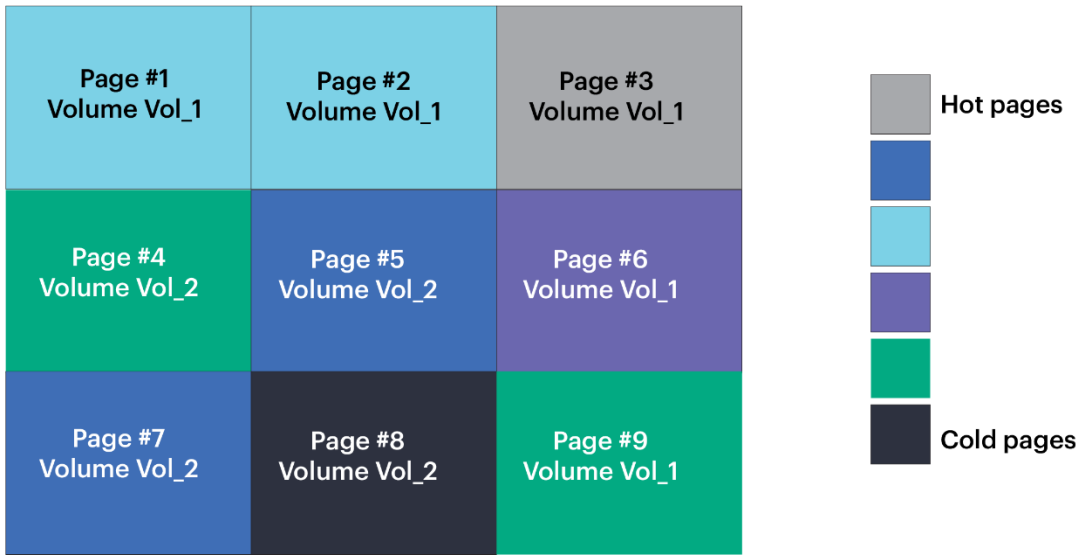


Figure 13. Heat map example of Table 5

**Important**

Tiering is not a function that can be enabled or disabled. The tiering engine is constantly on, and page ranking takes place even in a single-tiered system. The volume-level tier affinity setting is the only influence available to the user to manipulate the tiering engine.

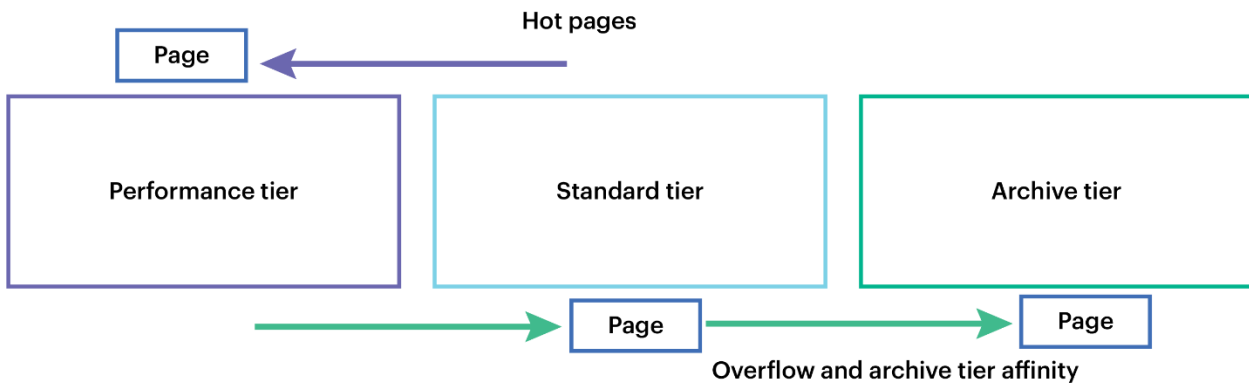


Figure 14. Performance tiering behavior

The migration of a page requires that it be read from one disk group and then written to another, which is an action that consumes performance. Under regular operation, several mechanisms are in place to reduce the performance impact of page migrations. The only condition for circumventing these mechanisms is during the removal of a virtual disk group from a pool. If there is sufficient capacity remaining in the pool, removing a disk group drains pages to the remaining disk groups.

General page migration rules:

- A page shall not migrate more often than every 15 minutes.
- Page migration is throttled to move not more than a fixed number of pages within a five-second interval.
- Unless a volume’s tier affinity is set to archive, cold pages are not demoted from a higher tier unless to make room for hot pages.

---

**Important**

Ideally, the performance tier should account for 80% or more of typical random I/O within 24 hours. After it is configured and workloads are established, evaluate daily capacity usage using the in-array I/O workload graph from within the **Capacity** panel. A safe quantity of SSDs to use when sizing a solution before an array enters production is between 10% and 20% of the standard and performance tiers' capacity combined. Although some workloads may still benefit, HPE recommends that this ratio not drop to less than 10%. If less than 10%, performance would likely become less predictable over time as the pool fills with data. Conversely, increasing the performance tier beyond 20% may devalue the cost savings made possible by the tiering engine.

---

**Tier affinity**

The HPE MSA automated tiering engine adapts to changing workloads across all volumes within a pool and efficiently locates data to the right tier automatically. However, users accustomed to alternative tiering mechanisms might want to pin a volume to a specific tier—for example, the performance tier—so that it receives SSD performance 100% of the time. However, due to the effectiveness of the

HPE MSA tiering implementation, this is unnecessary. Pinning a volume to the performance tier reduces the SSD capacity available to other volumes, thus introducing wastage and possibly causing a pool-wide degradation in performance.

As an example, database administrators are often concerned about the performance of the TempDB volume, which can impede the performance of a system if not kept on appropriately fast storage. However, this type of volume is consistently hot and naturally finds itself promoted to the fastest tier within a pool.<sup>8</sup>

Nevertheless, in some scenarios, the ability to locate much of a volume within a specific tier can prove desirable, and the tier affinity setting provides a mechanism that attempts to do so.

Tier affinity is a per-volume setting that can be applied during or after the creation of a volume. Its function is to modify the default page ranking algorithm so that pages for a volume are more likely to be favorably located in either the performance or archive tier. There are three settings, as shown in Table 6.

**Table 6.** Tier affinity settings

Setting	Effect
<b>Performance</b>	Increases the likelihood of being promoted to the highest tier in the pool.
<b>No Affinity</b>	Default setting and standard tiering engine rules: <ul style="list-style-type: none"><li>– Hot pages—Performance or highest tier</li><li>– Cold pages—Standard or next highest tier from current location</li><li>– Overflow<sup>9</sup>—Archive tier</li></ul>
<b>Archive</b>	The lowest tier in the pool absorbs newly written data, and there is an increased likelihood of page demotion when other volumes require capacity in the higher tiers.

**Note**

Changes to the tier affinity setting do not produce measurable results immediately. Tier affinity only acts on an existing page when it is either ranked for promotion (Performance tier affinity) or the space it occupies within a tier is needed for higher-priority data (Archive tier affinity).

---

<sup>8</sup> Provided the proportion of SSD within the pool is appropriately sized.

<sup>9</sup> Overflows are pages that are either demoted to the lowest tier to make room for hotter data or new data that does not fit into the higher tiers when first written.

The **No Affinity** setting is the system default and is recommended for the average volume. The **No Affinity** setting attempts to keep the hottest pages in the highest tier and all other pages in the next highest tier that has free capacity. When a pool has three tiers, the archive tier remains unused until no capacity remains on the tiers above it to avoid the needless reduction in performance that using it could cause. The archive tier is first accessed for page overflow and is used to store only the coldest pages or new data when all other tiers are full.

The **Performance tier affinity** setting might sound like a good choice for any volume but should be assigned sparingly. The typical use of the **Performance tier affinity** setting is for application data frequently in need of flash performance but that has extended periods between heightened read activity. In a correctly proportioned pool, it should not be possible to migrate the contents of all volumes to the performance tier by using the Performance tier affinity setting because there would be insufficient capacity, which limits its effectiveness. If all volumes must be in the performance tier, it would be more appropriate to have a dedicated all-flash pool or select a dedicated all-flash array from elsewhere in the HPE Storage portfolio.

More often, the tier affinity setting other than the default that may prove useful, is the **Archive tier affinity** setting which allows the use of the archive tier even when capacity remains in the other tiers. Because it is the lowest-performing tier in a pool, the archive tier is well suited to data that is infrequently accessed after it is initially written to disk, or when high performance is not required. Examples include disk images, test data, or CCTV video streams, which are all good candidates for this setting. There are two distinct benefits to employing this strategy:

- It frees up capacity in higher-performing tiers for use by more performance-sensitive volumes.
- It reduces the consumption of back-end I/O caused by page migration from one tier to another.

### SSD read cache

As a rule, performance tiering is the best way to increase overall system performance. However, in environments where workloads are mostly random read-heavy, SSD read cache offers excellent benefits at an even lower cost. SSD read cache does not count toward usable capacity and therefore does not require disk-level redundancy or a license. Additionally, although designed to accelerate random reads, the offloading of reads to SSD frees HDDs, potentially further improving performance.

SSD read cache supports pools containing either a single-tier or archive tiering and functions within the following set of rules:

- The minimum is one drive per pool (NRAID)<sup>10</sup>
- The maximum is two drives per pool (RAID 0)<sup>11</sup>
- The maximum addressable read cache size is 4.17 TB (3.8 TiB) per pool
- SSD read cache cannot be used with performance tiering in the same pool
- One pool configured with SSD read cache and the other pool with performance tiering

---

### Important

Ideally, SSD read cache should account for 80% or more of typical random read I/O within 24 hours. After configuring SSD read cache and establishing workloads, evaluate daily capacity usage using the in-array I/O workload graph from within the **Capacity** panel. A safe quantity of SSD is between 10% and 20% of the standard tier when sizing a solution before an array enters production. Although some workloads may still benefit, HPE recommends that this ratio stay greater than 10%. If less than 10%, performance could become less predictable as the pool fills with data. Conversely, increasing read cache beyond 20% may devalue the cost savings made possible by the SSD read cache mechanism.

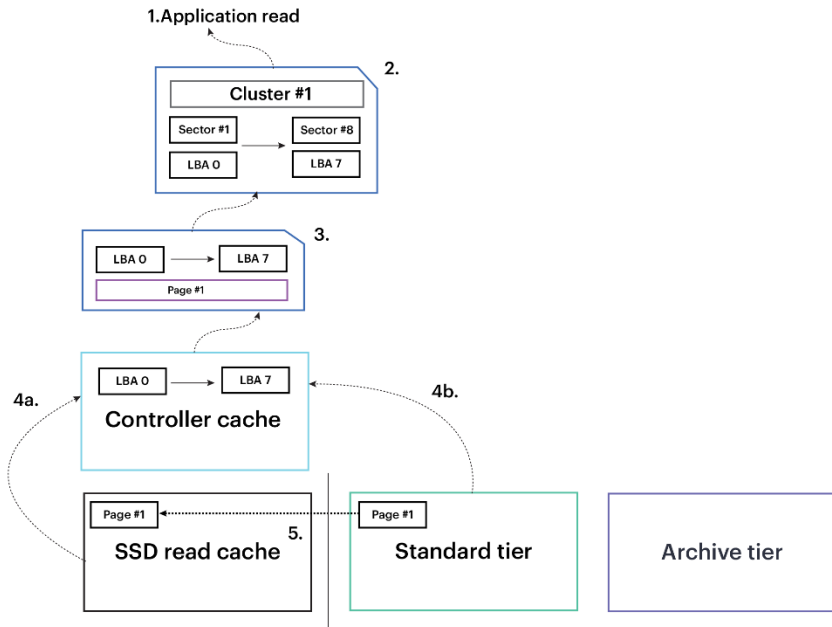
---

<sup>10</sup> NRAID (No RAID) is only applicable to read cache disk groups.

<sup>11</sup> RAID 0 is only applicable to read cache disk groups.

HPE recommends a single 3.84 TB SSD for use with SSD read cache. Higher capacity drives would result in stranded capacity while lower capacity drives consume additional drive slots and increase cost.

Figure 15 illustrates how data is fetched when using SSD read cache. However, except for Step 4a, the process is the same regardless of the pool's configuration. The array completes a read I/O using the fastest storage medium that holds a copy of the data. If performance tiering instead of SSD read cache is used, SSD is a possible location for requested data when that data is not in the controller cache (Step 4b).



**Figure 15.** Read mechanism

The steps illustrated in Figure 15 are:

1. An application requests data from the file system.
2. The file system reads the appropriate disk sectors.
3. HPE MSA virtual storage matches the resulting LBAs to the relevant pages within the pool.
4. Unless caching is disabled for a volume, recently read, written, or prefetched data might already be in the controller cache, in which case the I/O immediately completes. Otherwise:
  - a. SSD read cache, which is the next fastest medium, might contain the page because of a page copy during Step 5. If so, the relevant LBAs are read from the page and copied to controller cache for I/O completion.
  - b. If the SSD read cache does not contain a copy of the page, the LBAs are read from the mechanical disk group that holds the requested data.
5. Virtual storage uses hints from the controller cache regarding whether to copy the page into the SSD read cache. For example, a page containing randomly accessed blocks is likely to be nominated, but a page read sequentially is not.

### Virtual disk groups and wide striping

Virtual disk groups are the fundamental building block of a pool and defined as a group of individual disks using RAID to provide a logical unit of capacity and performance. A pool can consist of one to 16 disk groups. There are no enforced rules regarding the geometry of these disk groups, although there are best practices to assist with consistent performance. The goal of this paper is to explain HPE MSA technology well enough to understand why

certain best practices are recommended, but not to define them all. The HPE MSA 2070 / HPE MSA 2072 Storage arrays best practices paper contains the specific best practices that should be applied.

Virtual storage uses a controller’s general-purpose CPU to track page metadata and location. In contrast, RAID is an ASIC-accelerated disk group-level function responsible for the distribution of a page across individual disks. Although an HPE MSA array can support NRAID and RAID 0 for read cache disk groups, neither can be used in capacity disk groups because neither scheme protects from drive failure. Table 7 summarizes the RAID levels supported for use in virtual disk groups to provide usable capacity to a pool.

**Table 7.** Supported RAID levels for virtual disk groups

RAID level	Protection	Notes	Recommended tier <sup>12</sup>
<b>RAID 1</b>	Mirroring	<ul style="list-style-type: none"> <li>– Excellent performance for random workloads</li> <li>– Requires fewer drives than RAID 10</li> </ul>	Performance
<b>RAID 10</b>	Mirroring and striping	<ul style="list-style-type: none"> <li>– Same performance benefits as RAID 1 but allows for up to 256 drives per pool compared to 32 when using RAID 1</li> </ul>	Performance
<b>RAID 5</b>	Distributed parity (D+P) <sup>13</sup>	<ul style="list-style-type: none"> <li>– Good performance</li> <li>– Cost optimized</li> <li>– Should not be used with HDDs</li> </ul>	Performance
<b>RAID 6</b>	Advanced data guarding (D+P+Q) <sup>13</sup>	<ul style="list-style-type: none"> <li>– Better availability than RAID 5</li> <li>– Recommended when using less than 12 HDDs including spares</li> </ul>	Standard Archive
<b>MSA-DP+</b>	Erasur coding (D+P+Q+nS) <sup>13</sup>	<ul style="list-style-type: none"> <li>– Excellent availability</li> <li>– Great performance</li> <li>– Excellent rebuild times</li> <li>– Expandable</li> <li>– Recommended when using 12 HDDs or more</li> </ul>	Performance (all-flash only) Standard Archive

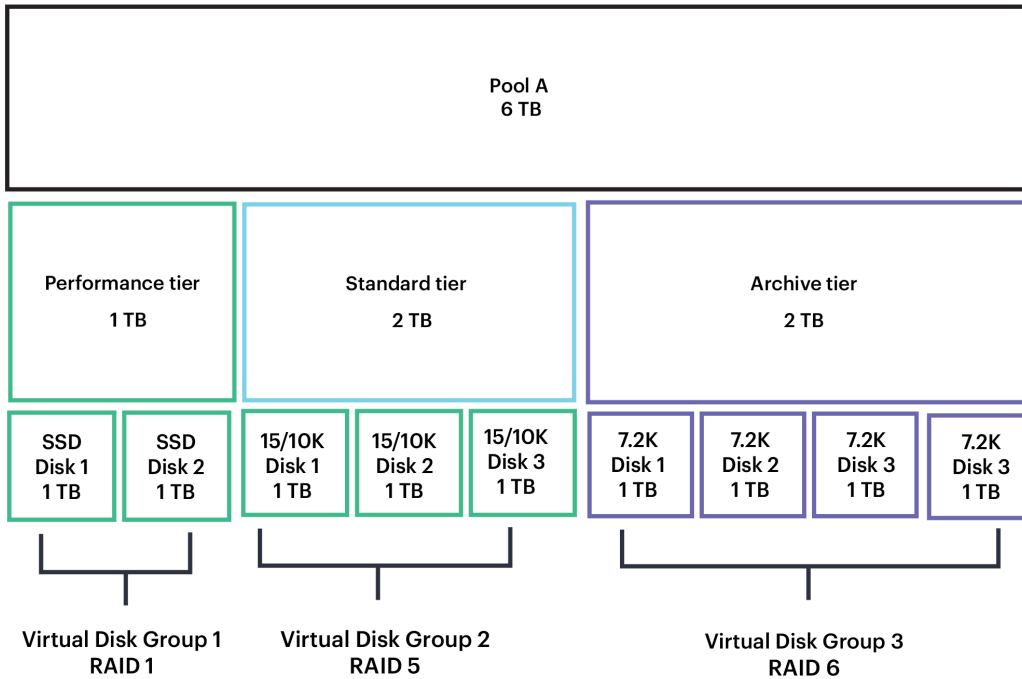
**Note**

MSA-DP+ is the default and recommended protection choice for both the standard and archive tiers (HDDs) as well as all-flash pools. Although supported, MSA-DP+ is not necessary within the performance tier of hybrid pools as data is additionally protected by the automated draining of degraded SSD disk groups to an HDD tier.

Figure 16 illustrates the relationships among physical disks, disk groups, tiers, and pools. Note that each disk group uses a given RAID type only as an example.

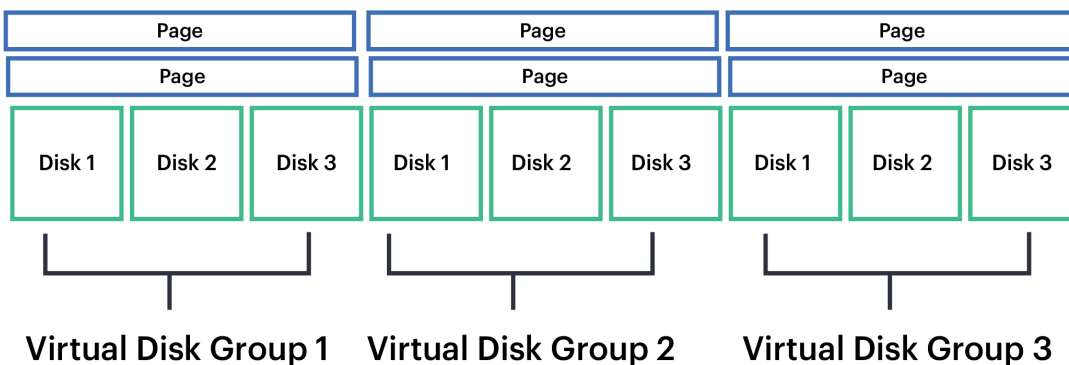
<sup>12</sup> Based on drive capacity and potential rebuild times.

<sup>13</sup> D=data, P=parity chunk #1, Q=parity chunk #2, nS=multiples of spare chunks.



**Figure 16.** Representation of a multitiered pool layout

Virtual storage distributes pages one at a time across all disk groups within the tier as part of a process known as wide striping. For tiers composed of mechanical drives, wide striping offers significant performance benefits by both reducing the effects of seek time latency and by potentially multiplying data transfer rates for a given volume.

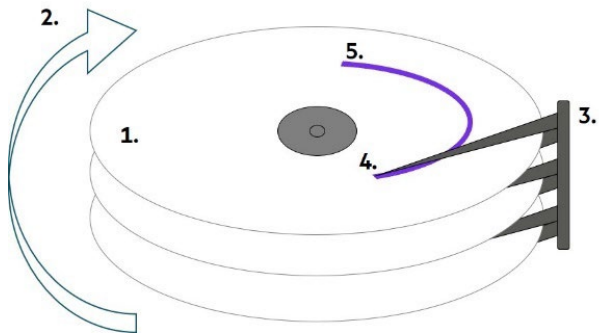


**Figure 17.** Wide-striped page distribution

It is helpful to understand the physical constraints of mechanical disk drives to understand how wide striping improves performance. Within a mechanical disk drive, a head connected to an actuator arm can move one-dimensionally between the outer and inner extremes of the disk to access data. It is the rotation of the platter that brings a second dimension, thereby allowing heads to access the entire disk surface.

However, the longer the platter takes to revolve, the longer I/O must wait to complete. The time it takes to move ahead to the correct track, rotate the platter so that it aligns with a given sector, and begin data transfer is known as the seek time. Seek times translate into latency, and the higher the latency the slower an application performs. Random I/O can easily overwhelm a mechanical disk drive due to constant consecutive random sector access and results in poor performance. However, sequential I/O is likely to result in fewer mechanical movements to seek a sector and it is well suited to this workload type. Additionally, if they are not disabled, controller cache prefetching algorithms increase sequential read performance by copying the next range of data into memory ahead of time from the next disk.

Figure 18 uses a dotted arc to depict the location of data. The figure illustrates how sequential I/O is well suited to spinning media because it does not require dramatic physical movements of the read/write head.

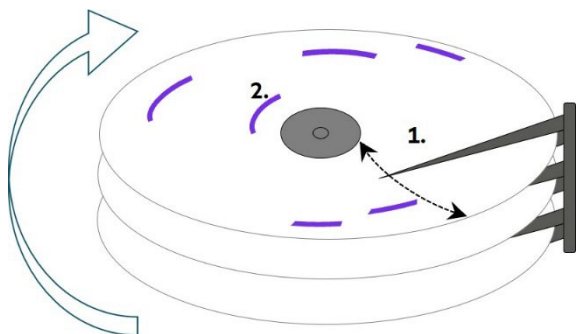


**Figure 18.** Internal view of a disk drive processing a sequential read/write operation

The components of a spinning disk drive illustrated in Figure 18 are:

1. Disk platter
2. Rotational direction of the disk
3. Read/write heads and actuator arm assembly
4. First sector where data is to be accessed
5. Last sector where data is to be accessed

In contrast, data accessed randomly requires a lot of physical movement of the read/write heads and the platter, which leads to longer access times.



**Figure 19.** Internal view of a disk drive processing a series of random read/write operations

Figure 19 shows:

1. Movement of actuator arm across the disk surface
2. Data to be accessed concurrently but at various physical locations

### MSA-DP+ disk groups

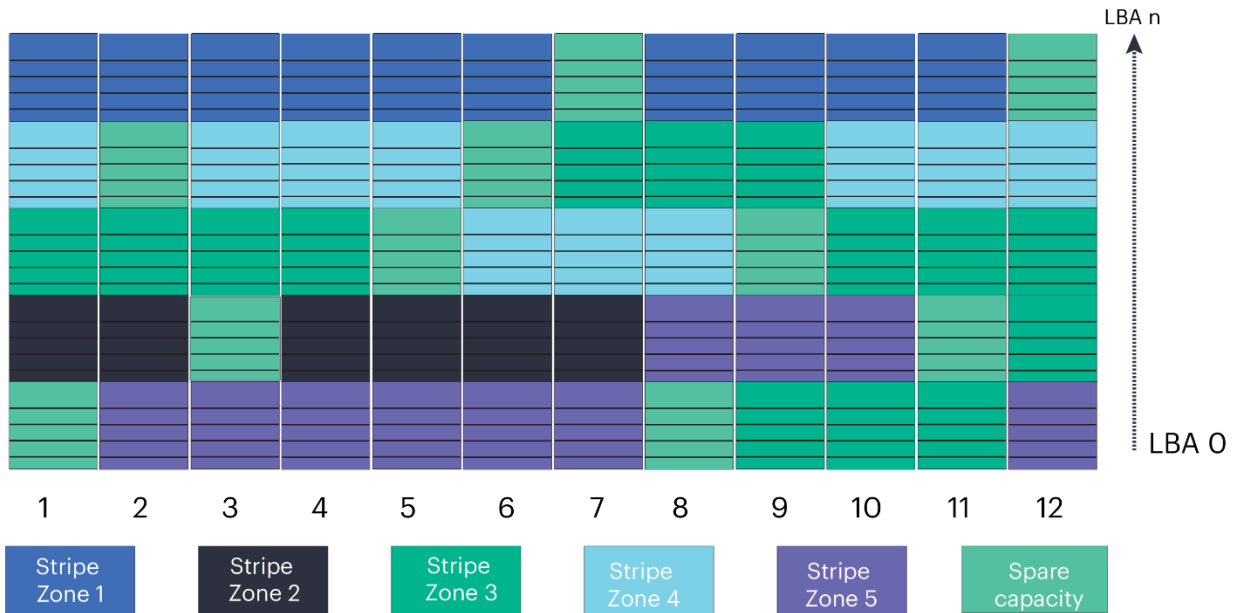
MSA-DP+ is a RAID type that offers superior, availability, flexibility, and rebuild times when compared to other disk group types, especially those that employ parity-based RAID schemes. MSA-DP+ uses erasure coding to allow disk groups to grow from 12 to 128 drives incrementally and to feature integrated sparing.

A problem that keeps traditional disk groups limited to a relatively low number of drives is that the greater the drive count, the greater the probability of disk failure within that group. RAID serves to protect against such failures, but as drive capacities increase, the time to rebuild lost data increases with it linearly. It is the combination of both drive capacity and their number within a disk group that introduces higher risk as both variable increases.

Although the HPE MSA intelligently rebuilds only allocated capacity, it still requires that there be compatible drives available or global spares assigned to the role. Additionally, the management of spare drives is often a growing

challenge that can lead to unplanned downtime, typically because they are unknowingly consumed by degraded disk groups. MSA-DP+ solves all these challenges and more.

Unlike other disk group types where every drive participates in a stripe, MSA-DP+ disk groups contain multiple stripe zones that are of a fixed size. The more drives that participate in the MSA-DP+ disk group, the more stripe zones there are. A stripe zone is composed of 2048 stripes laid out in a contiguous manner across the LBAs of each participating drive. Each of the 2048 stripes within a zone stores a single 4 MB page, totaling 8 GB of data across the zone. To demonstrate the rules of stripe zone distribution within a disk group, Figure 2 shows a small subsection of a much larger disk group composed of the 12-drive minimum for an MSA-DP+ disk group.



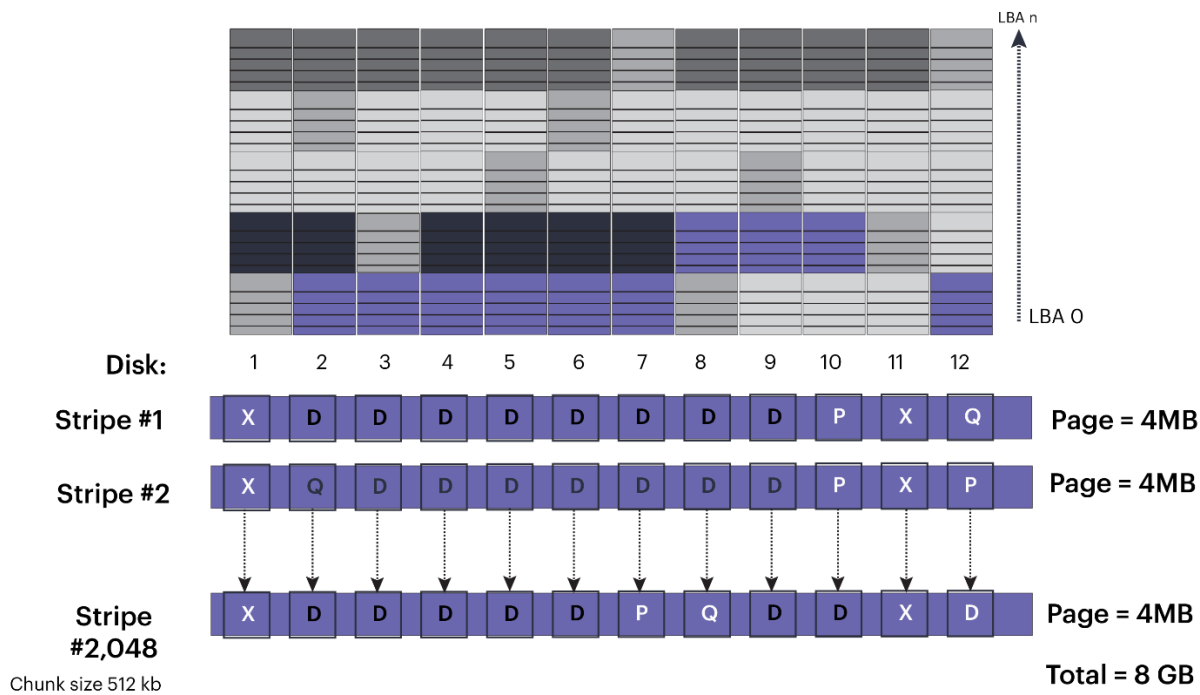
**Figure 20.** Example of multiple stripe zone and spare capacity within an MSA-DP+ disk group

Stripe zones obey fixed rules across the disk group:

- A stripe zone spans exactly ten drives, but the drives do not need to be adjacent physically or logically.
- Each drive can only contain one section of a stripe zone (2048 chunks).<sup>14</sup>

As illustrated in Figure 21, stripe zones are protected internally by RAID 6 in an 8+2 layout, which is eight chunks of data and two of parity (P&Q). Any additional drives in the disk group do not participate in the stripe zone, which for this example are Drives 1 and 11. As with any other RAID 6 implementation, parity rotates across all participating drives with each stripe. Each drive in a stripe holds 512 KB of user data or parity information.

<sup>14</sup> A chunk is the amount of contiguous data written per disk in a stripe.



**Figure 21.** Internal protection of an MSA-DP+ stripe zone using RAID 6

As drive technology evolves and their capacities increase, so do the size of the disk groups, which often fuels growing concerns regarding availability. However, MSA-DP+ employs several techniques to reduce the time necessary to recover from drive failure, which leads to faster rebuild times the more drives there are within a disk group.

**Table 8.** Comparing recovery times from critical to fully fault tolerant

	RAID 610x HDDs	MSA-DP+12x HDDs	MSA-DP+48x HDDs	MSA-DP+24x SSDs
<b>Rotational speed</b>	7.2K	7.2K	7.2K	SSD
<b>Drive capacity</b>	10 TB	10 TB	10 TB	3.84 TB
<b>Stripe layout</b>	8 + 2	8 + 2	8 + 2	8 + 2
<b>Hours to rebuild one drive (To degraded state)</b>	26.14	17.5	2.5	0.61
<b>Hours to rebuild two drives (To fully fault tolerant)</b>	47	35	22.5	3
<b>Average rebuild rate (Fully fault tolerant) (MB/S)</b>	82.07	119.05	617.25	1052.09

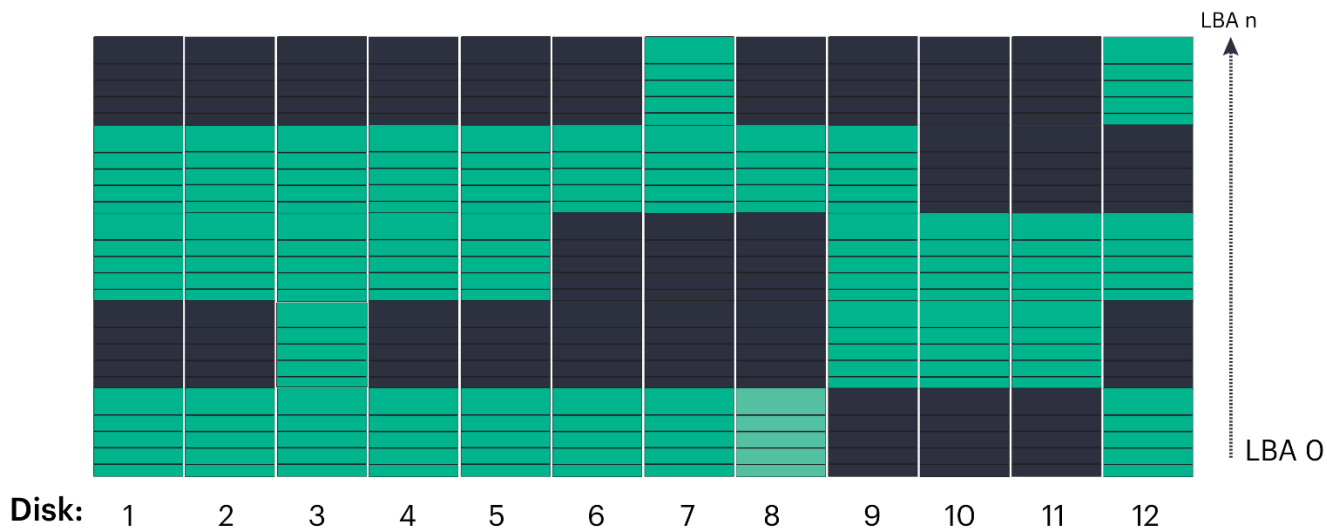
In addition to stripe zones, MSA-DP+ disk groups contain distributed spare capacity, which by default equals the capacity of two of the largest disks in the disk group. For example, if every drive is 10 TB and there are 12 drives within the disk group, then the group has 20 TB of spare capacity.

Distributing spare capacity across all drives removes two significant disadvantages of dedicated spare drives:

- A spare drive ordinarily sits idle and does not contribute towards the performance of a disk group.

- Disk group rebuild times are dependent on the performance of a single drive.

In the simplified representation of an MSA-DP+ disk group shown in Figure 22, each drive accounts for five groups of 2048 chunks. Therefore, the capacity of two drives to be used for sparing equates to ten groups of 2048 chunks distributed across ten drives within the disk group.



**Figure 22.** Example of spare capacity distribution within an MSA-DP+ disk group

To provide additional resiliency and as an equivalent of defining additional spare drives for traditional disk groups, it is possible to define a target spare capacity larger than the sum of two drive’s capacity. For example, if a disk group contained thirteen 1.2 TB drives, it would be possible to set a target capacity of 3.6 TB.

---

**Important**

After setting a target capacity higher than what is currently available, it is necessary to expand the MSA-DP+ disk group with additional drives. However, this action can only occur after the disk group has finished initializing.

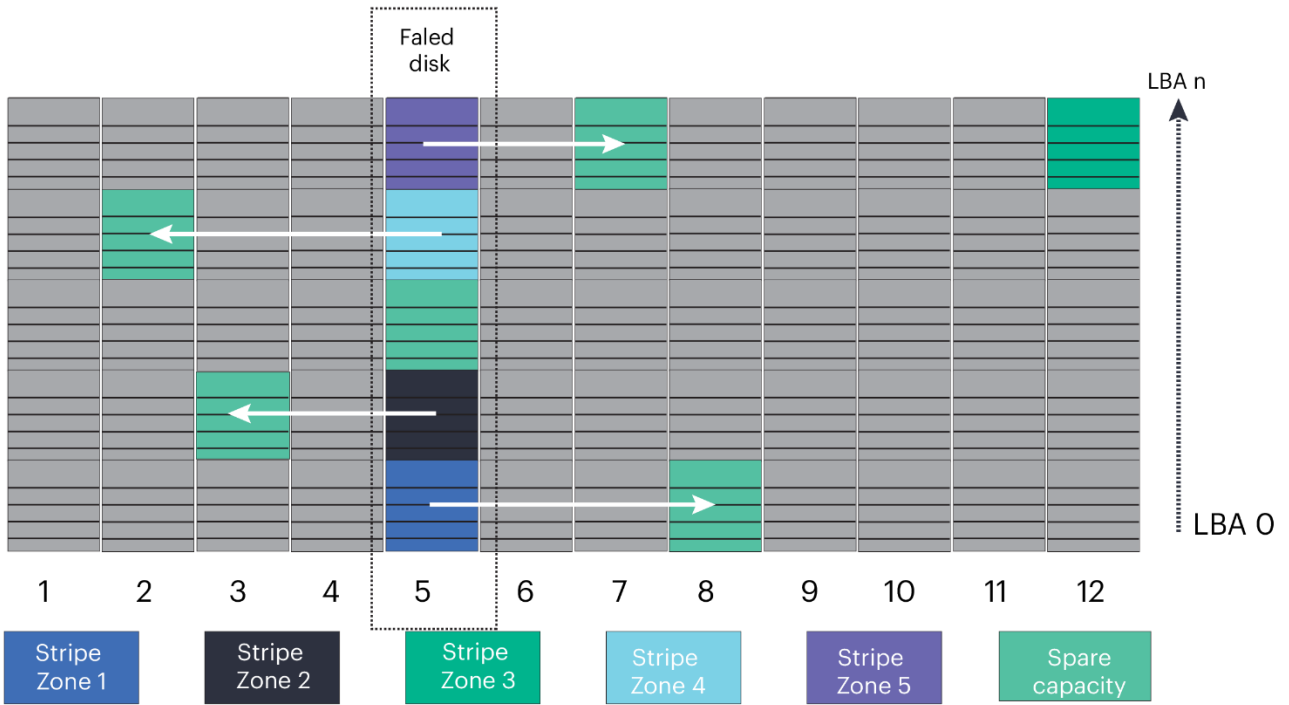
---

**Note**

Unlike other disk group sparing mechanisms, MSA-DP+ disk groups observe slot affinity for failed drives. If a drive fails and a new drive is installed in its place in the same location, the new drive automatically joins the failed disk group, and the rebuilding of missing data commences.

---

If a drive fails, missing sections of affected stripe zones rebuild into available spare capacity within the disk group. However, data cannot be rebuilt to a drive that already holds data for the affected zone as it would otherwise reduce the availability of the disk group and pool. Because a disk contains multiple zones, all drives that hold data for those stripes work together to rebuild data in a many-to-many relationship rather than many-to-one when using dedicated spare drives.



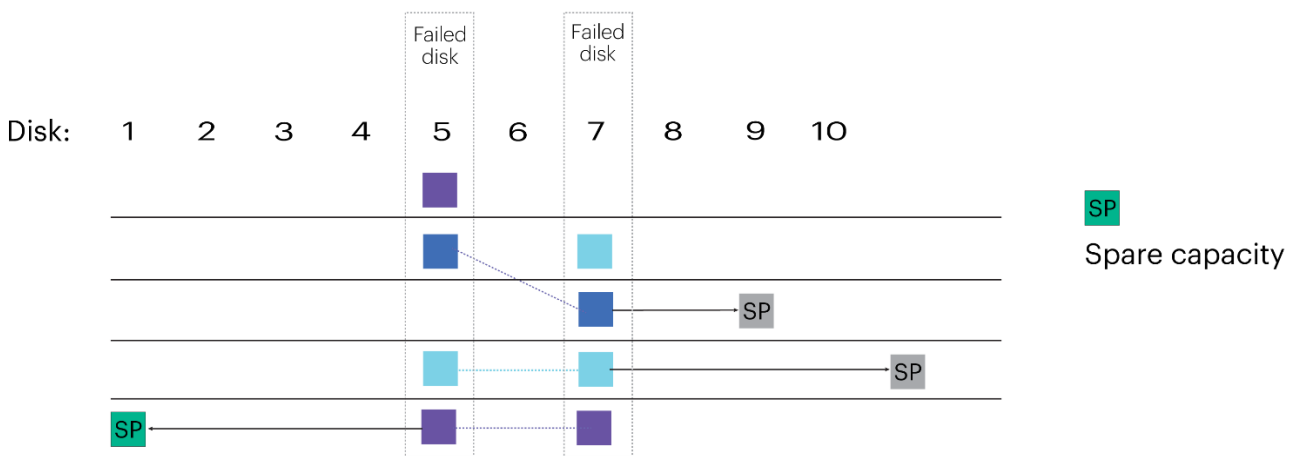
**Figure 23.** Example of rebuilding data located on a failed drive to spare capacity

When a single drive fails within an MSA-DP+ disk group, there is likely to be a mixture of unaffected (fault-tolerant) stripes and some that are degraded, meaning that one of the ten drives that hold data for that zone is unavailable. When a second drive fails, there is likely a mixture of fault-tolerant, degraded, and critical stripes that have lost two of their ten drives. To minimize the impact on availability, MSA-DP+ disk groups recover allocated capacity in two stages:

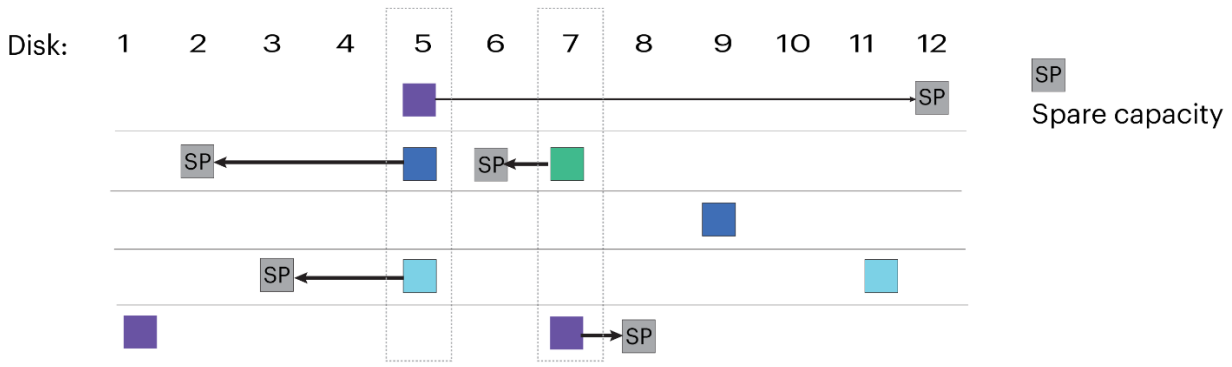
- Stage 1: Rebuild stripes that have sustained losses from both drives (Figure 24)
- Stage 2: Rebuild all remaining stripes (Figure 25)

Stage 1 of a rebuild assigns priority to returning critical zones to a degraded state as it protects the zone from data loss should a third drive holding zone data fail. After Stage 1 is complete, Stage 2 rebuilds remaining degraded zones until they are fully fault-tolerant.

A diagram depicts step one of a rebuild when two drives have failed in an MSA-DP+ disk group.

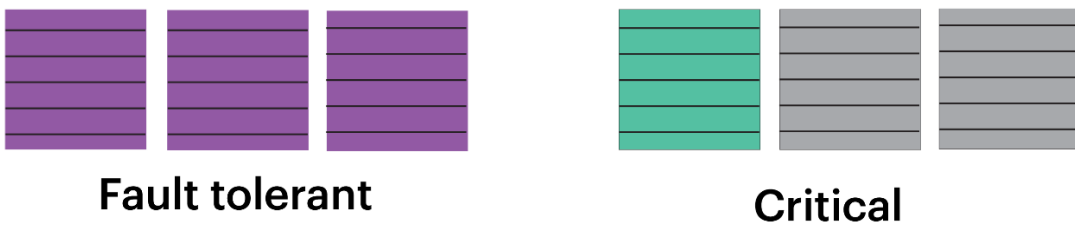


**Figure 24.** MSA-DP+ double disk failure rebuild Stage 1 is to protect critical stripe zones

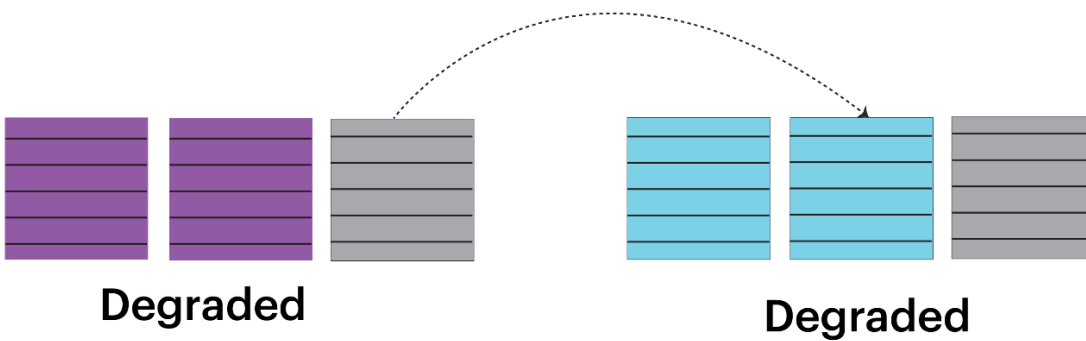


**Figure 25.** MSA-DP+ double disk failure rebuild Stage 2 is to return the disk group to a fault-tolerant state

If no spare capacity remains and two more drive failures occur, some stripe zones, the disk group, and the pool's state become critical. Depending on how many drives are in the disk group, some or perhaps many stripe zones may still be fault tolerant. To mitigate the danger of data loss, rebalance fault tolerant stripes (REFT) attempts to reallocate chunks from a fault-tolerant stripe zone to another that is critical. However, the same rules for zone distribution still apply, which means a drive cannot donate capacity to a zone that it already participates in.



**Figure 26.** Critical stripe zone, disk group, and pool before REFT



**Figure 27.** Degraded zones, disk group, and pool after REFT

**Important**

MSA-DP+ disk groups only action REFT if a system administrator has failed to replace failed drives. As per best practices, confirm that notifications are configured and working correctly.

**Sequential write optimization**

The power of 2 rule is a highly recommended best practice to prevent sequential write performance degradation caused by partial page writes to disk groups configured in RAID 5 or 6. This rule dictates that the number of disk

drives within a disk group holding data chunks rather than parity is a power of 2. Because the largest number of disk drives supported within a disk group including parity is 16, this means either two, four, or eight data chunks.

**Table 9.** Power of 2 chunk distribution

RAID level	# drives in a disk group	# data chunks in a stripe	# parity chunks in a stripe
RAID 5	3	2	1
RAID 5	5	4	1
RAID 5	9	8	1
RAID 6	4	2	2
RAID 6	4	4	2
RAID 6	6	8	2

RAID distributes data across all disk drives within a disk group through a process known as striping. As shown in Figure 28, when a parity RAID scheme such as RAID 5 is used, a stripe contains one parity chunk and as many data chunks as there are remaining disk drives within the disk group. For optimal performance, the array automatically chooses a disk group chunk size of 512 KB when following the power of 2 rule.

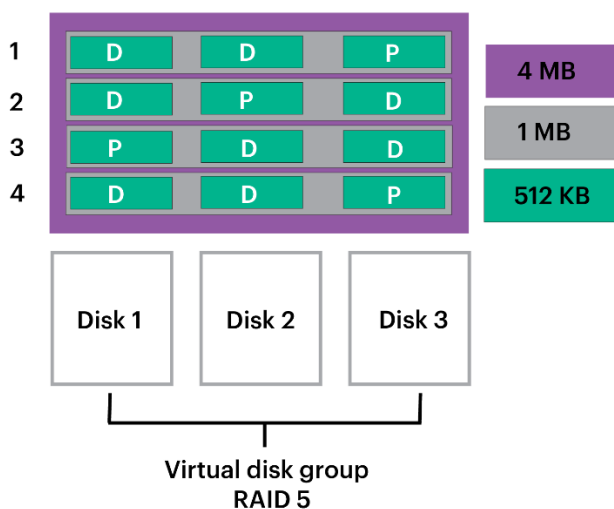
**Note**

Because of the high performance of SSDs, it is not necessary to follow the power of 2 rule for the performance tier or all-flash pools.

**Note**

An MSA-DP+ disk group incorporates the power of 2 rule automatically regardless of drive count, and no action is required to maintain conformity with this best practice.

In the example illustrated in Figure 28, each stripe uses two data chunks to store 1 MB of data. A parity chunk consumes the same amount of disk space as a data chunk but does not count toward capacity. This example requires four stripes to write a page. However, the number of stripes needed depends on how many disks there are within a virtual disk group. For example, a virtual disk group with nine disk drives requires one stripe to write a full page.



**Figure 28.** Example of how a page is distributed across physical disks when the power of 2 rule is followed

Disk groups that do not follow the power of 2 rule incur a performance penalty when writing sequential data, caused by two pages sharing the same parity chunk. As shown in Table 10, each write to a disk group requires additional I/O to recalculate and write parity. For example, when a single new chunk is written to one disk drive using RAID 5, four I/O are required:

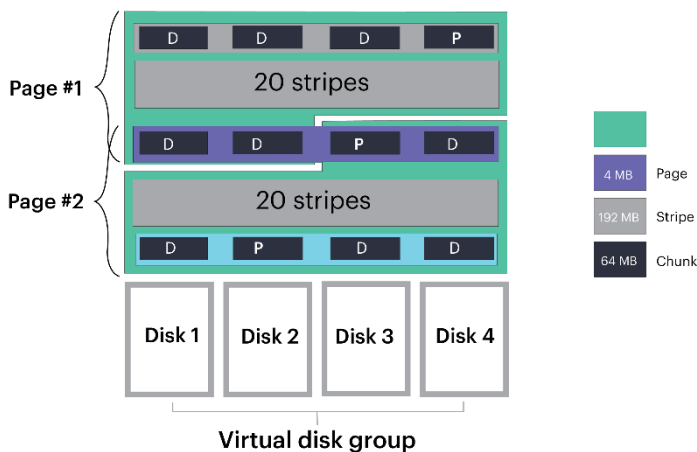
- Read the original data chunk
- Read the original parity chunk
- Write the new data chunk
- Write the new parity chunk

**Table 10.** RAID write penalties

RAID level	Disk group write I/O	I/O penalty
RAID 1	1	2
RAID 5	1	4
RAID 6	1	6
MSA-DP+	1	6

Page overlap leads to double the number of parity recalculations for shared stripes. The recalculation of parity is not a burden for the RAID ASIC of HPE MSA. However, the physical limitations of mechanical hard drives persist and additional I/O means more work for the disk drives.

When the power of 2 rule is not applied, the array tries to reduce the negative performance impact by decreasing the chunk size to 64 KB. This increases the number of stripes required to write a page but also decreases the **amount of data that needs to be read and written when recalculating parity for a share stripe.**

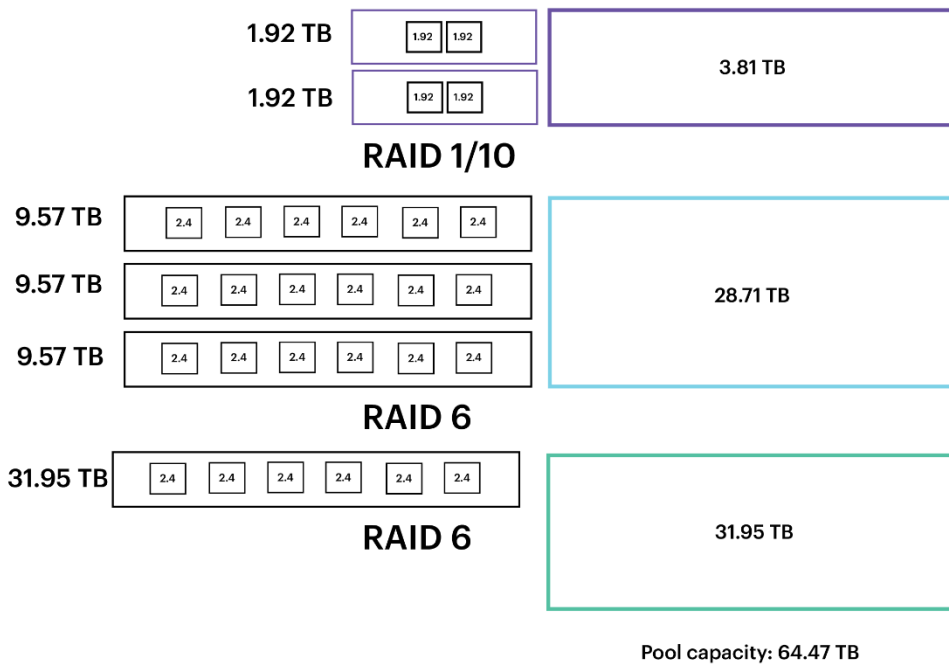


**Figure 29.** Example of how a page is laid out across physical disks when the power of 2 rule is not followed

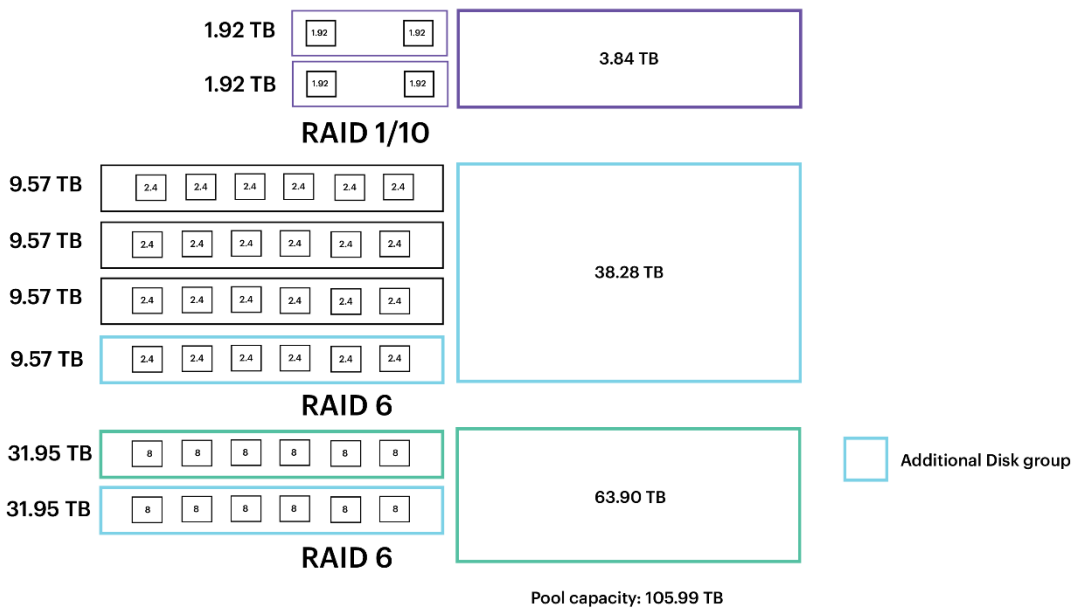
### Capacity and performance expansion

The capacity of a pool is expanded online by either adding more disk groups or by adding additional drives to MSA-DP+ disk groups. It is not possible to expand any other disk group except for those configured using MSA-DP+. An important consideration is when the size of either the standard or archive tier is increased, that the proportion of flash storage does not fall below the recommended minimums. Additionally, the more drives there are within a system, the higher the probability of drive failure. It is therefore critical to configure spare capacity for disk groups protected by MSA-DP+ or global spares for all others as per current recommendations found in the [HPE MSA 2070 / HPE MSA 2072 Storage arrays best practices](#) paper.

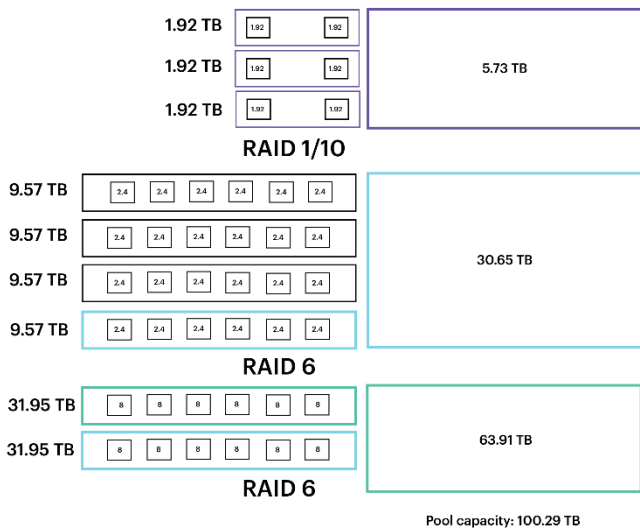
Figures 30 and Figure 31 illustrate before and after an expansion of a pool by adding additional disk groups. Figures 32 and Figure 33 add additional drives to MSA-DP+ protected disk groups.



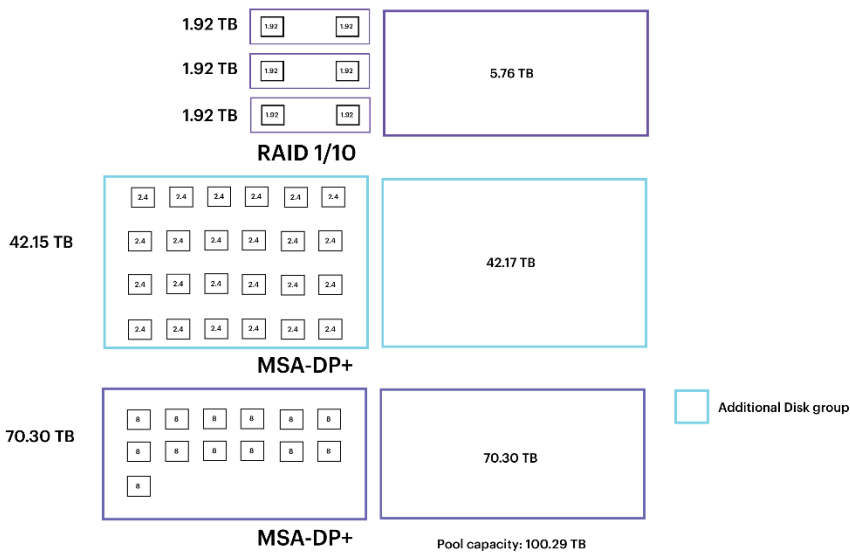
**Figure 30.** Example of a pool layout using traditional RAID disk groups before capacity expansion



**Figure 31.** Example of pool layout after capacity expansion by adding additional disk groups



**Figure 32.** Example of pool layout using MSA-DP+ HDD disk groups before capacity expansion

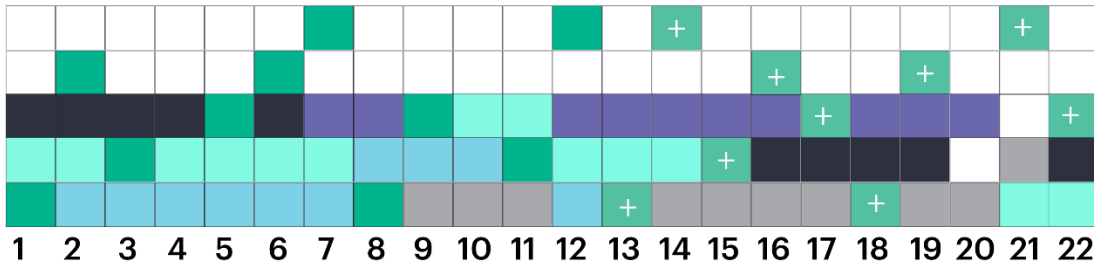


**Figure 33.** Example of pool layout using MSA-DP+ HDD disk groups after capacity expansion

Adding disk groups to a pool booth expands available capacity and initiates a rebalance of allocated pages across the tier to which the disk group belongs.

When an MSA-DP+ disk group is expanded, new drives first replenish spare capacity that has been consumed due to a failed drive or satisfy a new spare capacity target, or both. The remaining capacity is then added to the disk group and allocated stripe zones rebalance across the disk group.

Figure 34 demonstrates the expansion of capacity in addition to the increase of spare capacity by adding ten more drives to the disk group.



- Additional spare space  
(example of increasing spare capacity target)**
  
- Additional spare space  
(new stripe zones will be created during expansion)**

**Figure 34.** Example of an MSA-DP+ disk group layout after expansion from 12 to 22 drives, and the allocation of additional spare capacity

**Note**

It is supported to expand an MSA-DP+ disk group with larger drives but only recommended if they are no larger than twice that of the dominant drive in the group. For example, expanding a disk group containing 6 TB drives by adding 12 TB drives is supported, but further adding 18 TB drives, though supported, is not recommended.

**SSD drive endurance**

Another benefit of virtual storage, automated tiering, and SSD read cache is the ability to reduce the wear of SSDs, which have cells that eventually terminally degrade after a certain number of write cycles. Several techniques are used within an SSD to prevent accelerated wear, and some storage arrays take this further by using sophisticated leveling strategies. However, much of the concern around the wear of SSDs stems from an era when memory cell technology was more expensive to produce, and capacities were far smaller. Comparatively, SSDs today typically hold between five and twenty times the amount of data, which means that the likelihood of reaching a drive’s physical write limits has declined dramatically. Coupled with the effectiveness of the HPE MSA page ranking algorithms and with wide-striping, it is possible to exclusively use lower-cost RI drives under all workloads in either hybrid or all-flash configuration without an added risk of failure.

**Table 11.** Example of SSD drive wear with exaggerated random-write workloads in a hybrid configuration

1 TB total data per day	Performance tier	Standard tier
<b>Share of workload</b>	90% (random)	10% (sequential)
<b>Reads/writes %</b>	10 / 90	50 / 50
<b>Tier configuration</b>	<ul style="list-style-type: none"> <li>– Four 1.92 TB RI SSDs</li> <li>– One RAID 10 virtual disk group</li> </ul>	<ul style="list-style-type: none"> <li>– 12x 2.4 TB 10K enterprise SAS</li> <li>– One 12-drive MSA-DP+ virtual disk group</li> </ul>
<b>Pool capacity</b>	23.04 TB	
<b>Tier capacity</b>	3.84 TB	19.20 TB
<b>Proportion of pool</b>	17%	83%
<b>Daily writes to tier</b>	810 GB <sup>15</sup>	190 GB
<b>Daily drive writes</b>	405 GB <sup>16</sup>	n/a
<b>Years to drive wear out</b>	23.7 <sup>17</sup>	n/a

Table 11 demonstrates how both the automated tiering engine and wide striping decouple front-end I/O from the back-end I/O, thus reducing total drive writes. In the example, 1 TB of data is written to and read from the pool in 24 hours. Of the share of the workload, 90% of the I/O is random, and 90% of that is writes, which means a single drive absorbs 405 GB of data during that period. Although 405 GB might appear to be a lot, it accounts for only 21% of the 1.92 TB of data that can be written to each drive every day for five years before it would wear out. At this rate, each SSD would have 2.76 PB of unused wear after five years.

If an HPE MSA Storage array were in an all-flash configuration, each drive would absorb more writes compared to a hybrid configuration. However, as shown in the example in Table 12, even with a similar pool capacity and no incremental capacity growth, an unrealistically high number of daily writes would have to occur before a drive would wear out.

<sup>15</sup> 90% of 90%

<sup>16</sup> 21% of DWPD

<sup>17</sup> 20.7 years after warranty expiration

**Table 12.** Example of time until drive wear out in an all-flash configuration and typical capacity target

1 TB total data per day	Performance tier
Share of workload	100% (mixed)
Pool configuration	<ul style="list-style-type: none"> <li>– 12 1.92 TB RI SSDs</li> <li>– One MSA-DP+ virtual disk group</li> <li>– 1.92 TB spare capacity</li> </ul>
Pool capacity	16.9 TB
Total SSD lifetime writes	30.84 PB
Writes to pool (per day) until drive wear out	<ul style="list-style-type: none"> <li>– Three years (warranty): 28.16 TB</li> <li>– Five years (lifetime): 16.89 TB</li> <li>– Ten years: 8.44 TB</li> <li>– Twenty years: 4.22 TB</li> <li>– Thirty years: 2.81 TB</li> </ul>

### Thin provisioning

Thin provisioning is a well-established technology that limits initial monetary investment into physical storage capacity while offering greater flexibility and efficiency. Thin provisioning is achieved by reporting a volume size and required geometry to an operating system regardless of the available physical resources. A page is allocated, and physical capacity is consumed only when data is written to a volume. In addition to thin provisioning, virtual storage also provides two mechanisms for returning allocated capacity that is no longer in use back to the pool for use by other volumes and snapshots. These mechanisms enable a pool to grow and contract as required and result in a conservative approach to storage provisioning:

- The SCSI UNMAP command can be issued by modern operating systems to free physical capacity after deleting objects from the file system. When a contiguous range of sectors amounting to 4 MB has the UNMAP command applied, the page may be released so long as it is not referenced by an array snapshot.
- For older operating systems that do not support UNMAP, software tools or full formatting can be used to write zeroes across the entire volume and, therefore, pages. Pages containing zeroes are detected and released as part of the disk scrubbing maintenance task.

Thin provisioning requires monitoring and adequate planning so that physical capacity is not exhausted. Upon reaching defined or system default utilization thresholds, an HPE MSA storage system sends alerts to defined users. It is possible to disable overcommitment at the pool level, which can assist with managing capacity allocation for base volumes. However, disabling overcommitment also requires careful management because snapshots also require the allocation of capacity. Because the number of array snapshots can become many and unpredictable, disabling pool overprovisioning can easily lead to unexpected and total capacity consumption.

### Thin rebuilds

Because unallocated pages do not consume physical disk space, recovery from a degraded disk group is faster. Except for SSD read cache, if a disk fails or goes offline, the system begins rebuilding the disk group starting first with allocated pages, thereby minimizing the time needed to bring the system back to a fault-tolerant status.

## Licensing

The HPE MSA Advanced Data Services (ADS) Suite license is a single-license SKU for HPE MSA Gen7 Storage systems. It includes:

- Performance tiering
- 512 snapshots and volume copy
- Remote snapshot replication

---

#### Note

The HPE MSA Advanced Data Services Suite license is optional for the HPE MSA 2070 array. HPE MSA 2072 systems include the license along with two 1.92 TB SSDs.

---

#### Important

If both SSDs and HDDs are provisioned within the same system, even if in different pools then an HPE MSA Advanced Data Services Suite license is required. A license is not required when SSDs are used as read cache.

---

Table 13 demonstrates when a license is required based on the combination of drives and the model of the HPE MSA Storage array.

**Table 13.** License requirements

Array	Single drive type (HDD or SSD)	Mixing any HDD <sup>18</sup> types within the same system <sup>19</sup>	Coexistence of both a performance tier and any other tier within the same system	SSD read cache
HPE MSA 2070	No	No	Yes	No
HPE MSA 207	No	No	Included	No

## Data protection

An HPE MSA array provides several technologies in addition to RAID to provide increased resiliency and recovery from failure. This paper does not address the array-based asynchronous replication capabilities of the Remote Snap Replication (RSR) feature. If near-synchronous replication is required, consider Zerto, a Hewlett Packard Enterprise company.

### Snapshots

The HPE MSA uses redirect-on-write (RoW) snapshot technology to protect volumes. RoW snapshots are superior to the copy-on-write mechanism (CoW) because it is flexible and removes the performance penalty associated with copying data elsewhere in the system.

In taking a snapshot, the system transparently creates a duplicate volume, which becomes the location of all future writes. However, rather than copying data, lookup tables are used by both the base volume and the snapshot to reference shared pages. The system tracks how many volumes reference the page and locates new data accordingly. When there are no snapshots for a volume, the reference count is 1, and data is written as usual. However, one or more snapshots of that volume increase the reference count to two or more, which results in the allocation of new pages from the pool, thus preserving the original data.

<sup>18</sup> 15K, 10K, or 7.2K hard disk drives.

<sup>19</sup> The term system refers to the HPE MSA array and includes either pool.

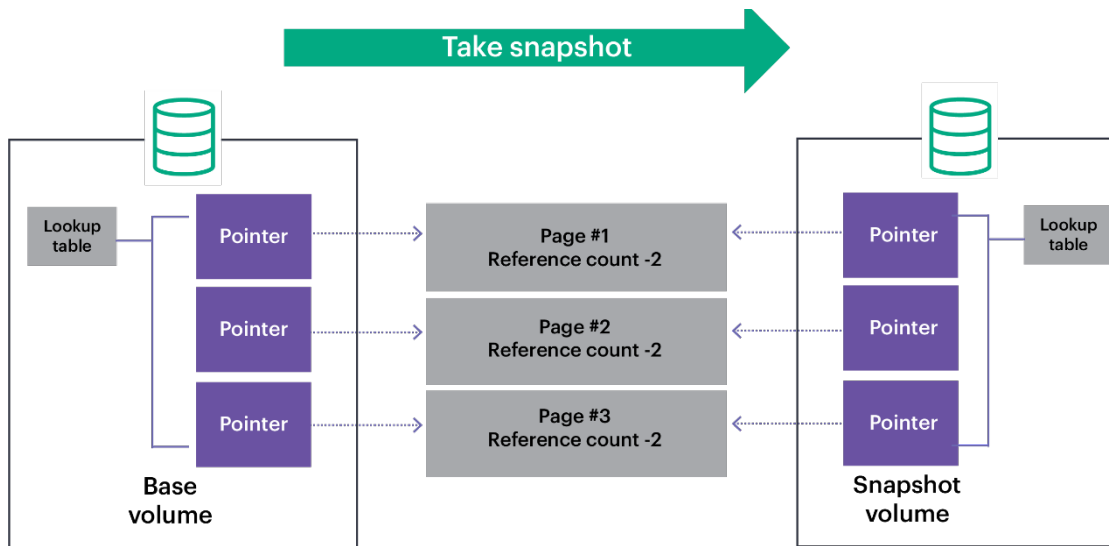


Figure 35. RoW snapshot mechanism

## Conclusion

Virtual storage provides the foundation for a multitude of essential features and capabilities that tackle the challenges faced by small and medium-sized customers. Virtual storage, as found in HPE MSA Gen7 Storage, alleviates management overhead, and provides advanced technology to reduce both initial and ongoing costs all while improving availability and performance far beyond all previous generations.

## References

[HPE MSA Gen7 Storage QuickSpecs](#)

[HPE MSA 2070/2072 Storage Best Practices](#)

[HPE MSA Health Check](#)

[Sign up for HPE updates](#)

**Learn more at**

[HPE.com/storage/MSA](https://hpe.com/storage/MSA)

Visit [HPE.com](https://hpe.com)

[Chat now](#)

© Copyright 2025 Hewlett Packard Enterprise Development LP. The information contained herein is subject to change without notice. The only warranties Hewlett Packard Enterprise products and services are set forth in the express warranty statements accompanying such products and services. Nothing herein should be construed as constituting an additional warranty. Hewlett Packard Enterprise shall not be liable for technical or editorial errors or omissions contained herein.

a50011791ENW, Rev. 1

HEWLETT PACKARD ENTERPRISE

[hpe.com](https://hpe.com)

