

# IFP41 Series

## Commercial Touch Display User Guide

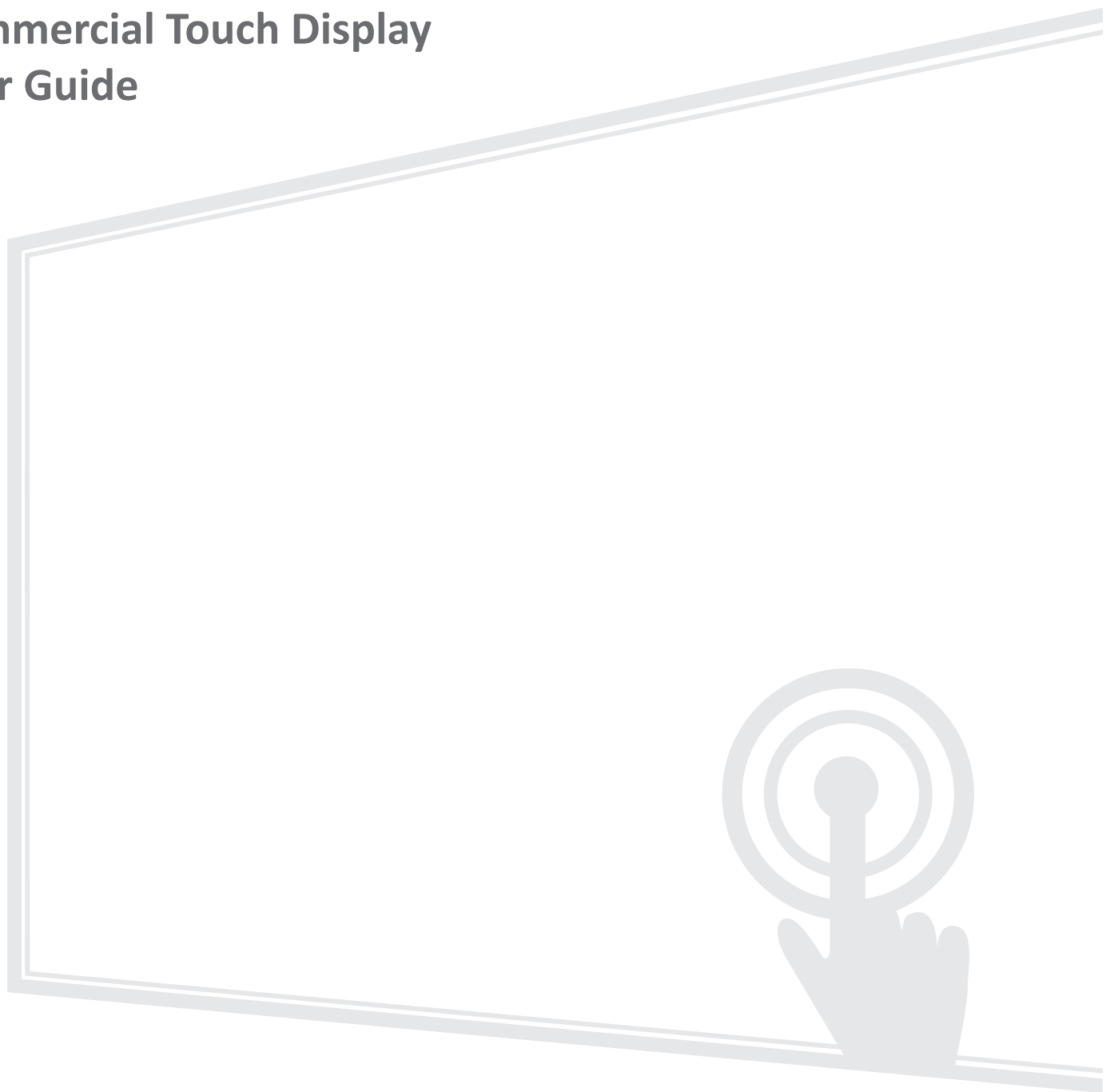

**IMPORTANT:** Please read this User Guide to obtain important information on installing and using your product in a safe manner, as well as registering your product for future service. Warranty information contained in this User Guide will describe your limited coverage from ViewSonic® Corporation, which is also found on our web site at <http://www.viewsonic.com> in English, or in specific languages using the Regional selection box of our website.

Model No. VS21061 | VS21062 | VS21063 | VS21064 | VS21065

P/N: FP5541-1-1C | IFP6541-1-1C | IFP7541-1-1C | IFP8641-1-1C | IFP9841-1-1C | IFP5541-1-2B | IFP6541-1-2B  
| IFP7541-1-2B | IFP8641-1-2B | IFP9841-1-2B | IFP5541-1-2C | IFP6541-1-2C | IFP7541-1-2C | IFP8641-1-2C |  
IFP9841-1-2C | IFP5541-1-2M | IFP6541-1-2M | IFP7541-1-2M | IFP8641-1-2M | IFP9841-1-2M

## **Thank you for choosing ViewSonic®**

As a world-leading provider of visual solutions, ViewSonic® is dedicated to exceeding the world's expectations for technological evolution, innovation, and simplicity. At ViewSonic®, we believe that our products have the potential to make a positive impact in the world, and we are confident that the ViewSonic® product you have chosen will serve you well.

Once again, thank you for choosing ViewSonic®!

# Safety Precautions

Please read the following **Safety Precautions** before you start using the device.

- Keep this user guide in a safe place for later reference.
- Read all warnings and follow all instructions.
- Do not use the device near water. To reduce the risk of fire or electric shock, do not expose the device to moisture.
- Never remove the rear cover. This display contains high-voltage parts. You may be seriously injured if you touch them.
- Avoid exposing the device to direct sunlight or other sources of sustained heat.
- Do not install near any heat sources such as radiators, heat registers, stoves, or other devices (including amplifiers) that may increase the temperature of the device to dangerous levels.
- Use a soft, dry cloth to clean the external housing. For more information, refer to the "Maintenance" section.
- When moving the device, be careful not to drop or bump the device on anything.
- Do not place the device on an uneven or unstable surface. The device may fall over resulting in an injury or a malfunction.
- Do not place any heavy objects on the device or connection cables.
- If smoke, an abnormal noise, or a strange odor is present, immediately turn the device off and call your dealer or ViewSonic®. It is dangerous to continue using the device.
- The device is a monitor with an LED backlight intended for general office use.
- Do not attempt to circumvent the safety provisions of the polarized or grounding-type plug. A polarized plug has two blades with one wider than the other. A grounding-type plug has two blades and a third grounding prong. The wide blade and the third prong are provided for your safety. If the plug does not fit into your outlet, obtain an adapter and do not attempt to force the plug into the outlet.
- When connecting to a power outlet, DO NOT remove the grounding prong. Please ensure grounding prongs are NEVER REMOVED.
- Protect the power cord from being treaded upon or pinched, particularly at the plug, and at the point where it emerges from the equipment. Ensure that the power outlet is located near the equipment so that it is easily accessible.
- Only use attachments/accessories specified by the manufacturer.
- When a cart is used, use with caution when moving the cart/equipment combination to avoid injury from tipping over.

- Disconnect the power plug from the AC outlet if the device is not being used for a long period of time.
- Place the device in a well-ventilated area. Do not place anything on the device that prevents heat dissipation.

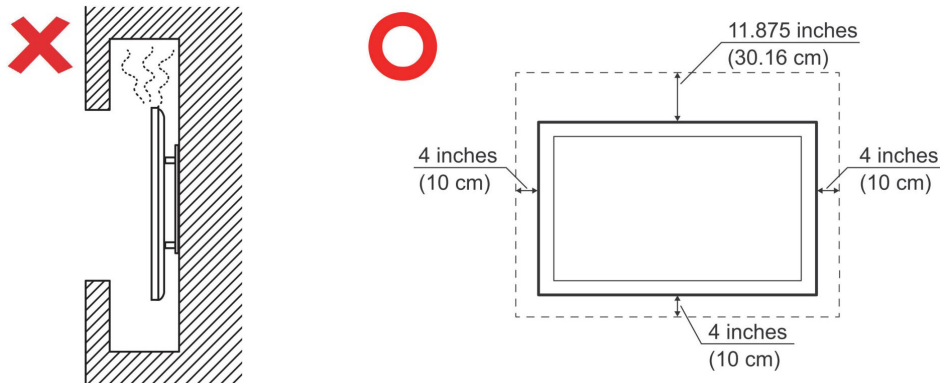

- Refer all servicing to qualified service personnel. Service will be required when the unit has been damaged in any way, such as:
  - » if the power supply cord or plug is damaged
  - » if liquid is spilled onto or objects fall in the unit
  - » if the unit is exposed to moisture
  - » if the unit does not operate normally or has been dropped
- The handles must not be used for mechanical lifting or hoisting. They are designed only for manual handling.
- Team lifting is recommended:
  - » For 86" products: At least four people are recommended for handling.
  - » For products larger than 86": At least six people are recommended for handling.

## Important

To ensure the optimal performance and longevity of your display, it is essential to follow the recommended handling, mounting, and storage procedures. Placing the display in a horizontal position can lead to a range of potential issues, including:

- Excessive stress on the display's structural components, resulting in the formation of cracks or distortions along the edges.
- Uneven weight distribution, which can cause the screen to warp, sustain internal damage, or crack over time.
- Thermal-related damage, as the internal components may not be able to dissipate heat as intended, leading to potential failure or permanent damage.

Furthermore, altering the display's form can also compromise the integrity of its internal components, including the sensitive LCD cells, which can result in a permanent degradation of the display's quality.

To prevent such issues and maintain the display's optimal condition, it is recommended to always mount, handle, transport, and store it in a vertical position. Failure to do so may void the warranty and compromise the display's performance and lifespan.

**Note:** Any damage resulting from the misuse or improper handling of the display is not covered under warranty.

# Contents

<b>Safety Precautions.....</b>	<b>3</b>
<b>Introduction .....</b>	<b>10</b>
Package Contents .....	10
Wall Mount Kit Specifications (VESA) .....	11
Product Overview .....	12
Front View .....	12
Rear View .....	12
Control Panel.....	13
Remote Control .....	17
Overview .....	17
<b>Making Connections.....</b>	<b>21</b>
Connecting to Power .....	21
Connecting to Video Inputs and Enabling Touch.....	22
USB Type C Connection .....	23
HDMI Connection .....	23
DisplayPort Connection.....	23
VGA Connection .....	23
RS-232 Connection .....	24
USB Connection .....	25
USB Type A .....	25
USB Type C .....	25
Network Connection.....	26
Media Connection .....	27
Audio Connections .....	28
Audio In .....	28
Audio Out .....	28
SPDIF .....	28
Video Output .....	29
HDMI Out .....	29
Optional Connections .....	30
Slot-in PC (OPS Slot) Installation .....	30
Wi-Fi Card (Wi-Fi Slot) Installation .....	31

<b>Using the Display.....</b>	<b>32</b>
Turning the Display On/Off.....	32
Initial Launch Setup .....	33
Sign-in Screen .....	40
How to Sign Up.....	40
Guest Mode .....	41
Sign In.....	41
Home Screen .....	42
Home Screen Message.....	42
Toolbar .....	43
Applications .....	45
On-Screen Display (OSD) Menu - General Settings .....	46
Input Settings .....	48
Display Settings .....	50
Eye Care.....	52
Display Settings .....	53
Google Launcher.....	53
Network & Internet.....	53
Connected Devices.....	55
Apps .....	56
Notifications .....	57
Storage .....	59
Sound .....	60
Display.....	61
Wallpaper & Style.....	62
Accessibility .....	63
Security & Privacy.....	65
Passwords & Accounts .....	67
Digital Wellbeing .....	68
Google .....	69
Advanced.....	70
System .....	71
About Device .....	72
Tips & Support.....	73
Android Settings Menu Tree .....	74

<b>Pre-installed Applications and Settings.....</b>	<b>119</b>
AirSync.....	119
Manager .....	120
myViewBoard .....	121
<b>RS-232 Protocol.....</b>	<b>122</b>
Description .....	122
RS-232 Hardware Specification .....	122
LAN Hardware Specification.....	123
RS-232 Communication Setting.....	123
LAN Communication Setting .....	123
Command Message Reference.....	123
Protocol .....	124
Set-Function Listing.....	124
Get-Function Listing .....	132
<b>Appendix.....</b>	<b>143</b>
Display Modes .....	143
DisplayPort .....	143
HDMI .....	144
USB Type C .....	144
VGA .....	145
HDMI Out .....	145
Troubleshooting .....	146
Maintenance.....	148
General Precautions.....	148
Cleaning the Screen.....	148
Cleaning the Case .....	148

## **Regulatory and Service Information ..... 149**

Compliance Information.....	149
FCC Compliance Statement.....	149
Industry Canada Statement.....	149
CE Conformity for European Countries.....	150
Declaration of RoHS2 Compliance.....	151
ENERGY STAR Statement.....	152
Indian Restriction of Hazardous Substances .....	153
Product Disposal at End of Product Life .....	153
Copyright Information .....	154
Customer Service .....	155
Limited Warranty .....	156
Mexico Limited Warranty.....	159

# Introduction

## Package Contents

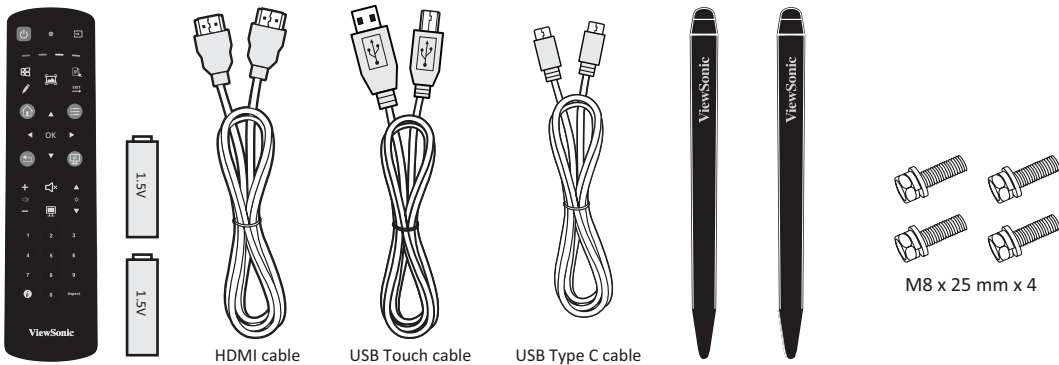
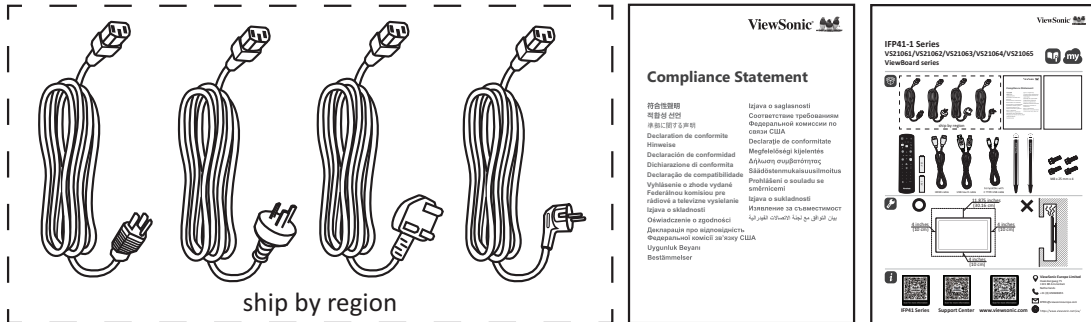

- 2x AAA Batteries
- Compliance Statement
- HDMI Cable (3 m)
- Power Cord (3 m)
- Quick Start Guide
- Remote Control
- 4 x Replacement Pen Nibs
- USB Type C Cable (1.8 m)
- USB Touch Cable (3 m)
- 4 x Screws
- 2 x Touch Pens

### Note:

- The cables included in your package may vary depending on your country. Please contact your local reseller for more information.

# Wall Mount Kit Specifications (VESA)

**Note:** Please follow the instructions in the wall mount installation guide to install your wall mount. If attaching to other building materials, please contact your nearest dealer.

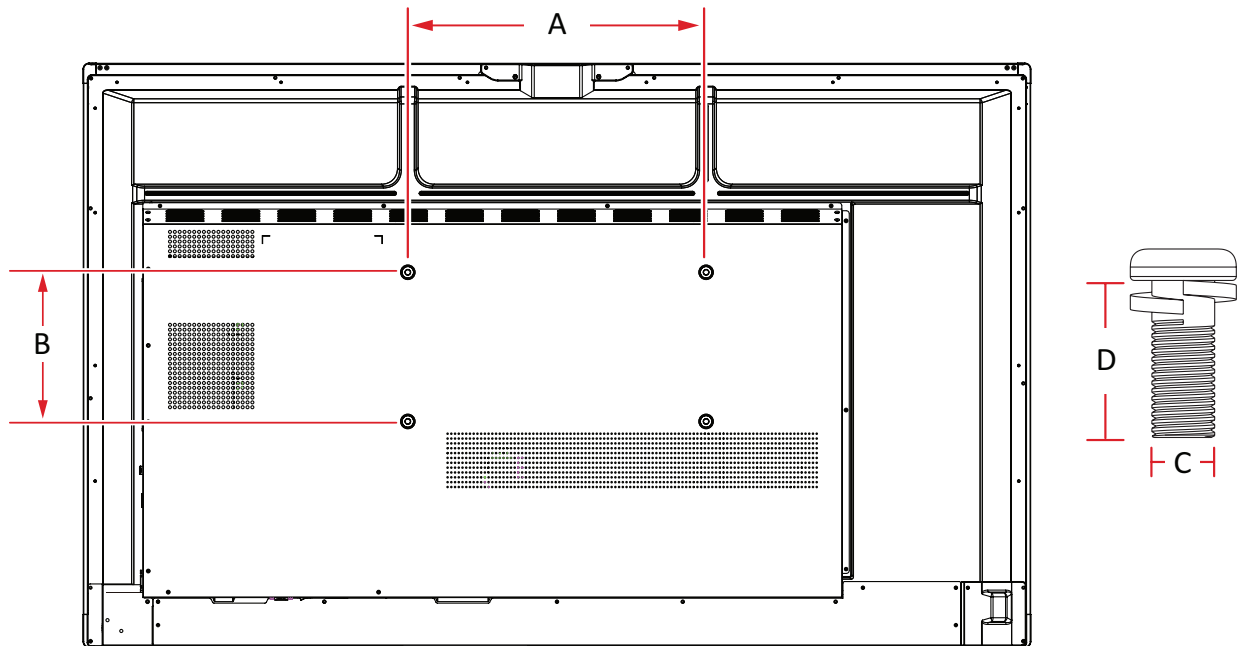

Model	VESA Spec. (A x B)	Screw Spec. (C x D)	Screw Quantity
IFP5541	400 x 200 mm	M8 x 25 mm	4
IFP6541	600 x 400 mm		
IFP7541	800 x 400 mm		
IFP8641	800 x 600 mm		
IFP9841	800 x 600 mm		

## Important:

- Do not use screws longer than the specified length, as they could damage the display.
- Refer to the Safety Precautions section for further detailed safety considerations when handling and installing.
- Mount the display in landscape orientation only.

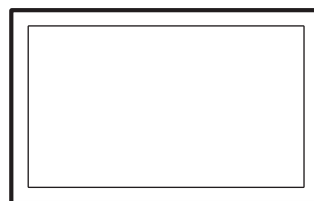
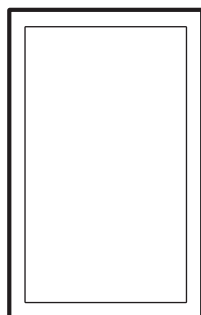

# Product Overview

## Front View

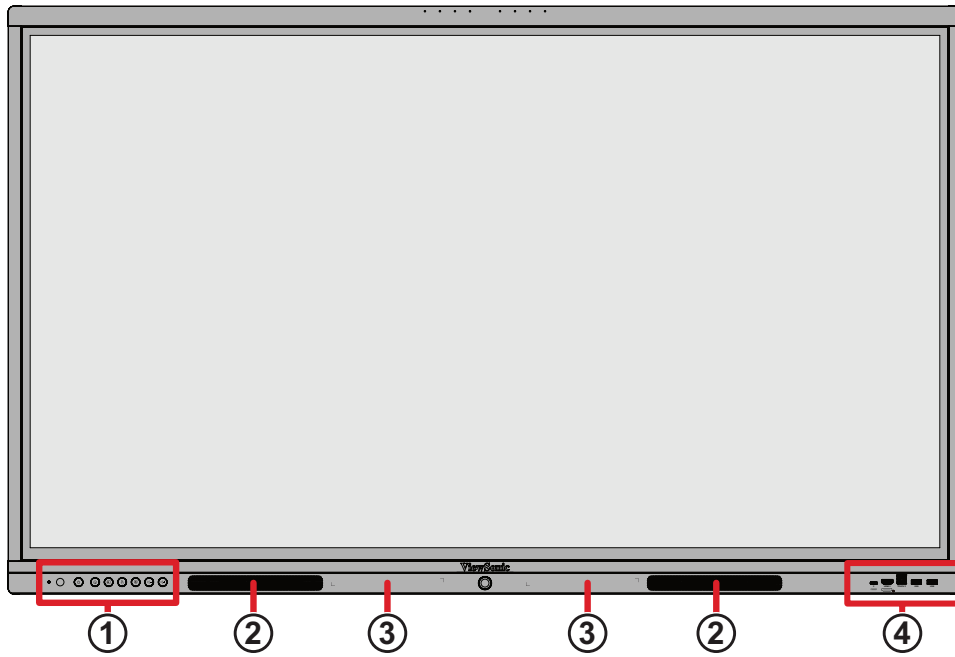

## Rear View

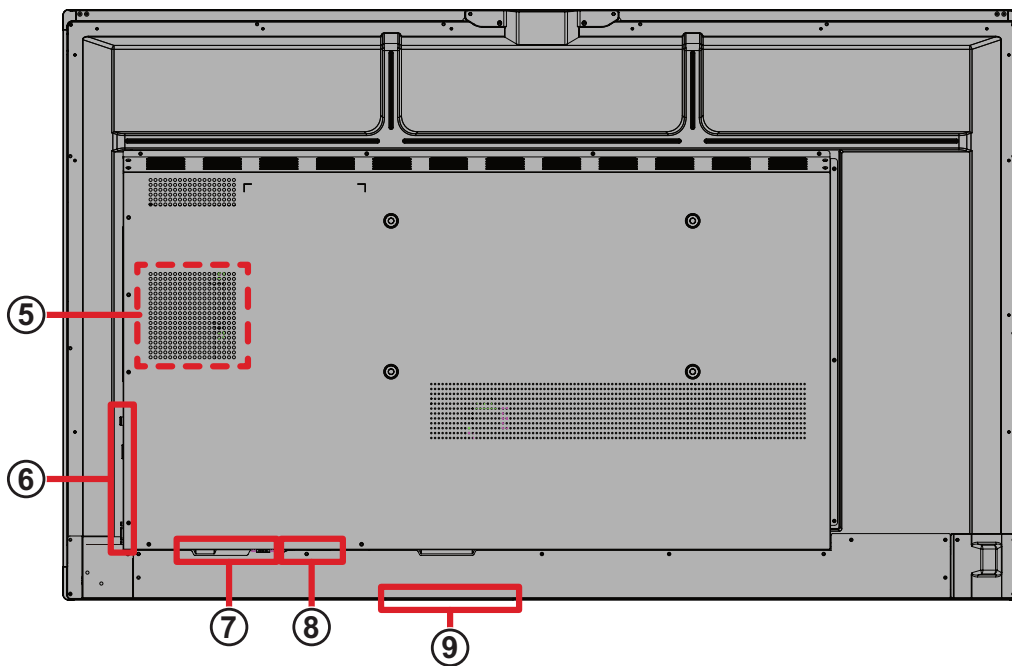

Part		Part	
1	Control Panel	6	Side I/O
2	Speaker	7	Rear I/O
3	Pen Holder	8	Power Switch & AC IN
4	Front I/O	9	Wi-Fi Slot
5	OPS Slot		

## Control Panel

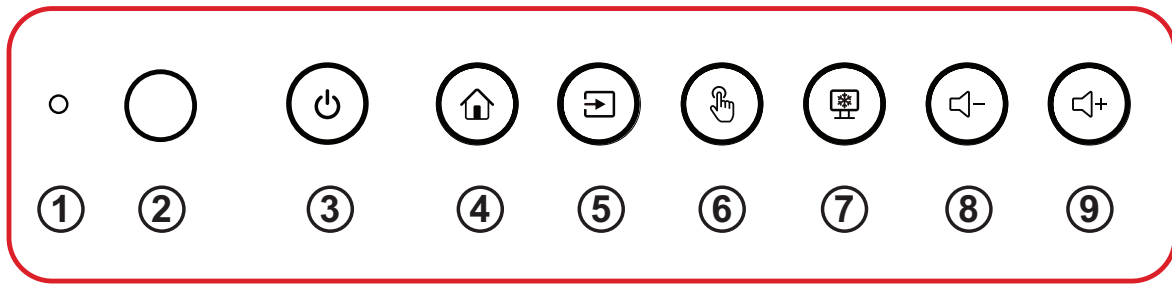

Item		Description
1	IR Receiver	Remote control IR receiver.
2	Ambient Light Sensor	Dim or brighten the display screen based on the surrounding light conditions.
3	Power	Turn the display on or off.
4	Home	Return to the ViewBoard's main interface.
5	Input Source	Open the Input Source menu.
6	Touch	Enable or disable the touch screen function.
7	Freeze	Freeze the current image on the screen.
8	Volume Down	Decrease the sound level.
9	Volume Up	Increase the sound level.

## Front I/O

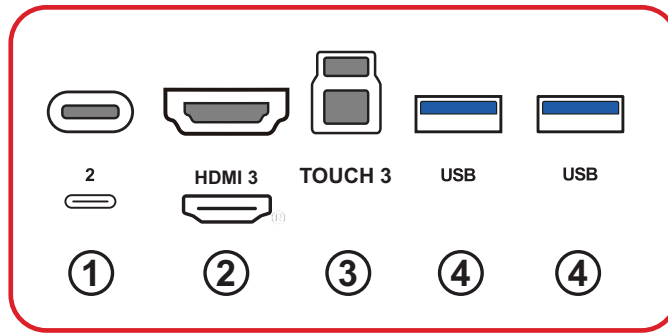

Connection Type		Description
1	USB Type C	<ul style="list-style-type: none"> <li>• USB 3.2 Gen 1 standard.</li> <li>• Supports DP v. 1.2 with audio, video, and touch.</li> <li>• Supports LAN by 10M/100M.</li> <li>• Supports power charge up to 100W<sup>1</sup>. Power charge supported: 5V/3A, 9V/3A, 15V/3A, 20V/5A.</li> </ul>
2	HDMI	<ul style="list-style-type: none"> <li>• Connect to a computer, set-top box, or other video device with HDMI output.</li> <li>• Supports 4K display; HDMI v. 2.1; CEC.</li> </ul>
3	USB Type B	<ul style="list-style-type: none"> <li>• Touch signal output to external computer</li> <li>• After connection (with an external computer), the device connected to the <b>USB</b> port can directly be used by the external computer.</li> </ul> <p><b>Note:</b> Pairs with the <b>HDMI 3</b> port.</p>
4	USB Type A	<ul style="list-style-type: none"> <li>• USB 3.2 Gen 1 standard.</li> <li>• Connect USB devices such as hard disks, keyboard, mouse, etc.</li> <li>• Automatically switches between the external computer and ViewBoard.</li> <li>• Supports: 5V/0.9A (x2).</li> </ul>

1– Available only when the OPS PC module is not installed. Power delivery will be limited to 15W when an OPS PC module is connected.

## Rear I/O

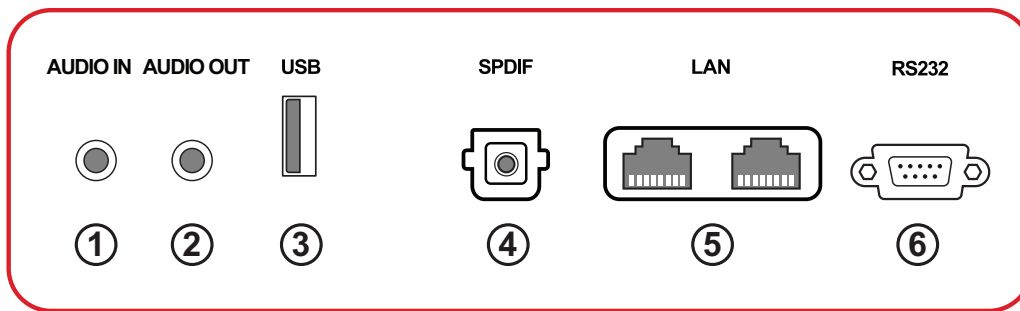

Connection Type		Description
1	Audio In	External computer audio input.
2	Audio Out	Audio output to an external speaker/headset.
3	USB Type A	<ul style="list-style-type: none"><li>• USB 2.0 standard.</li><li>• For ViewBoard source use only.</li></ul>
4	SPDIF	Multichannel sound via optical signals.
5	RJ45	Standard (10M/100M/1000M) Internet connection interface. Features hub support for network sharing.
6	RS232	Serial interface; used for mutual transfer of data between devices.

## Side I/O

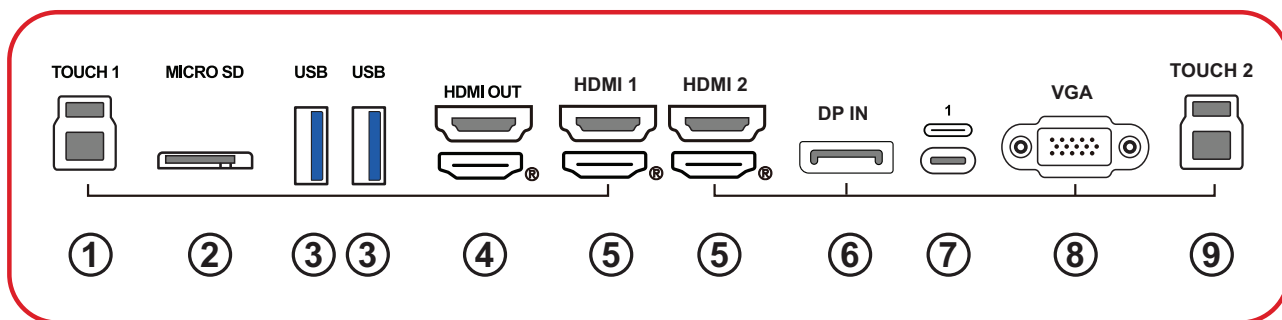

Connection Type		Description
1	USB Type B	<ul style="list-style-type: none"> <li>• Touch signal output to external computer</li> <li>• After connection (with an external computer), the device connected to the <b>USB</b> port can directly be used by the external computer.</li> </ul> <p><b>Note:</b> Pairs with the <b>HDMI 1</b> port.</p>
2	microSD	Data only; up to 1 TB.
3	USB Type A	<ul style="list-style-type: none"> <li>• USB 3.2 Gen 1 standard.</li> <li>• Connect USB devices such as hard disks, keyboard, mouse, etc.</li> <li>• Automatically switches between the external computer and ViewBoard.</li> </ul>
4	HDMI	<ul style="list-style-type: none"> <li>• Connect to a computer, set-top box, or other video device with HDMI input.</li> </ul> <p><b>Note:</b></p> <ul style="list-style-type: none"> <li>• Supported by select models.</li> <li>• CEC and ARC are not supported.</li> </ul>
5	HDMI	<ul style="list-style-type: none"> <li>• Connect to a computer, set-top box, or other video device with HDMI output.</li> <li>• Supports 4K display; HDMI v. 2.1; CEC; ARC.</li> </ul>
6	DisplayPort	<ul style="list-style-type: none"> <li>• Supports 4K display; DisplayPort v. 1.2.</li> </ul>
7	USB Type C	<ul style="list-style-type: none"> <li>• USB 3.2 Gen 1 standard.</li> <li>• Supports power charge up to 15W. Power charge supported: 5V/3A.</li> </ul>
8	VGA	External computer video input.
9	USB Type B	<ul style="list-style-type: none"> <li>• Touch signal output to external computer</li> <li>• After connection (with an external computer), the device connected to the <b>USB</b> port can directly be used by the external computer.</li> </ul> <p><b>Note:</b> Pairs with the <b>HDMI 2/DP IN/VGA</b> ports.</p>

# Remote Control Overview

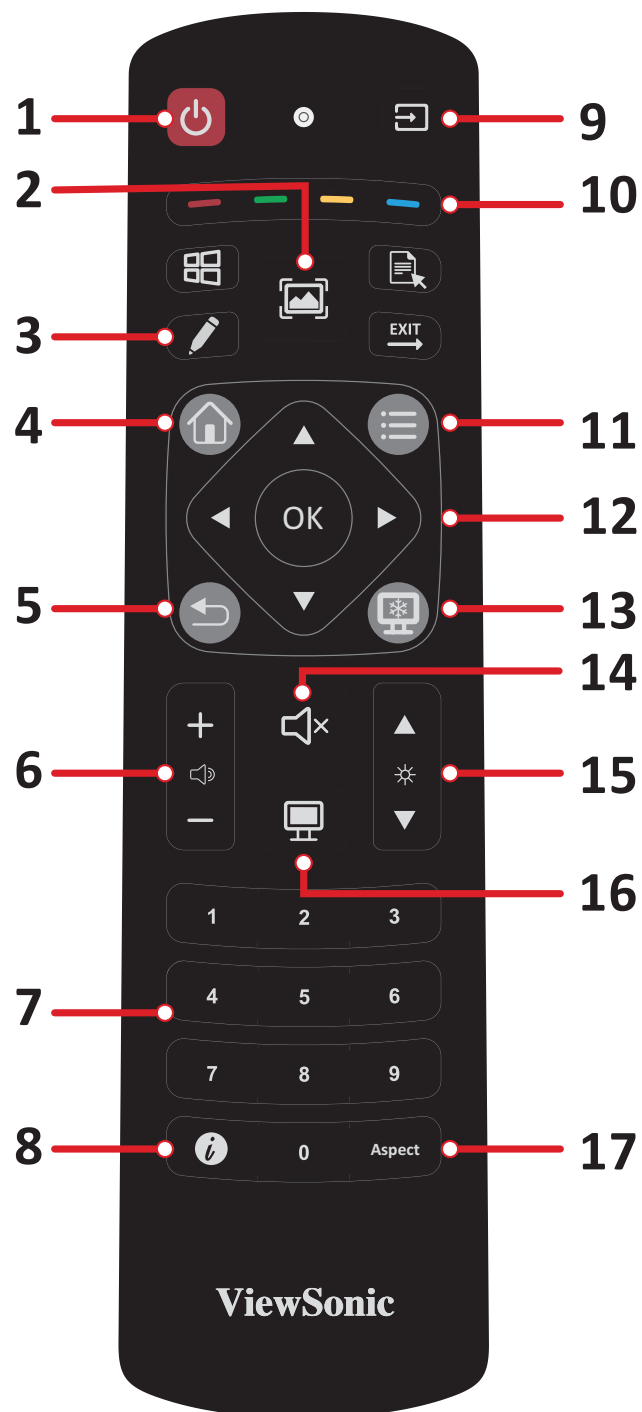

Button		Description	
1	Power	Turns the display on or off.	
2	Screenshot	Captures an image of the screen.	
3	Home	Goes to the Home screen.	
4	OK	Confirms the selected item.	
5	Return	Returns to the previous screen.	
6	Volume	Adjusts the volume level.	
7	Keypad	Numeric keypad.	
8	Information	Opens the <b>About</b> menu.	
9	Input Source	Opens the <b>Input Source</b> menu.	
10	Media Control	Red	Plays or pauses media.
		Green	Stops media playback.
		Yellow	Fast forwards or skips media.
		Blue	Rewinds media or returns to previous media.
11	Settings	Opens the settings menu.	
12	Navigation	Selects an item or adjusts the value in the menu.	
13	Freeze	Holds the on-screen image.	
14	Mute	Stops audio output.	
15	Brightness	Adjusts the brightness level.	
16	Blank	Hides the on-screen image.	
17	Aspect Ratio	Changes the aspect ratio.	

## Receiver Range

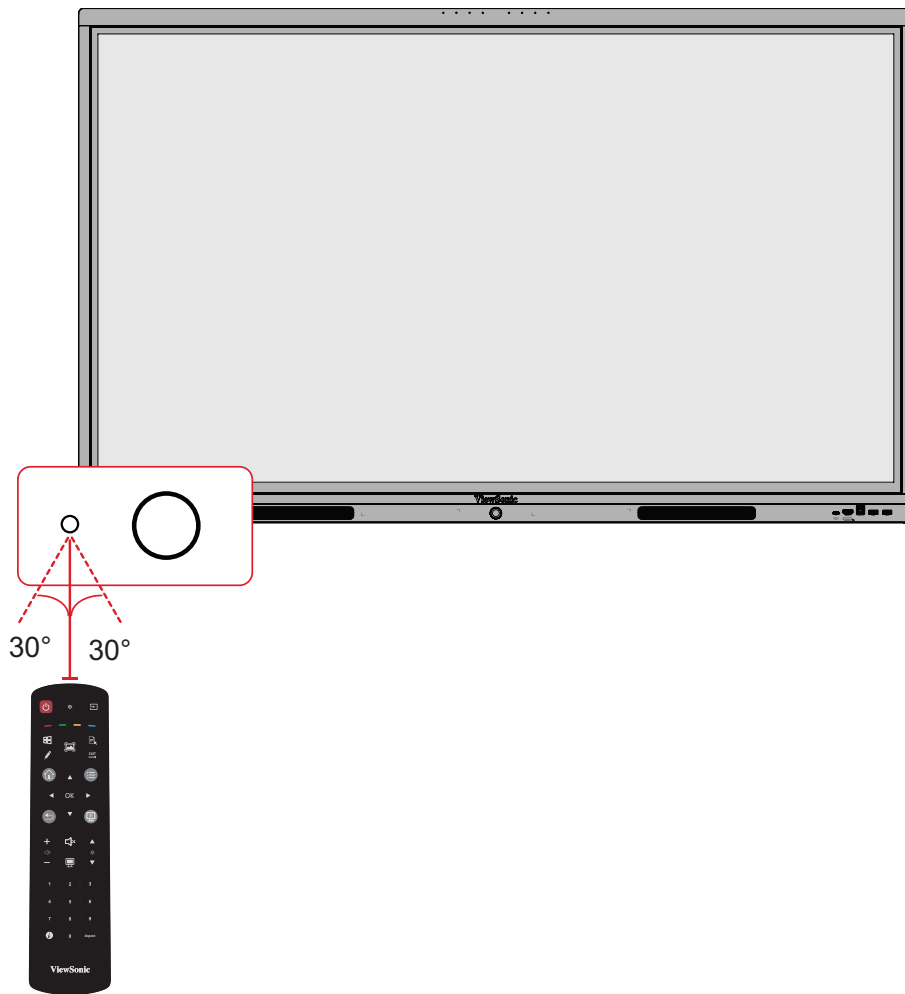

For optimal performance, aim the remote control directly at the IR Receiver. The maximum operation range is 8 m (26 ft) with a horizontal and vertical field of view of  $\pm 30$  degrees.

## Installing the Batteries

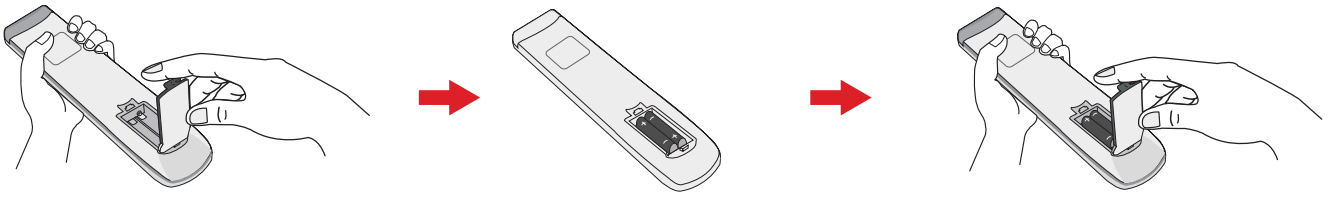

1. Open the battery compartment by removing the battery cover.
2. Insert two AAA batteries, ensuring correct polarity.
3. Replace the battery cover and press it down until it clicks into place.

### Note:

- Store the remote control and batteries away from heat and humidity.
- Use only recommended battery types.
- Remove batteries when not in use for extended periods.
- Dispose of old batteries following the manufacturer's instructions and local regulations.

# Making Connections

## Connecting to Power

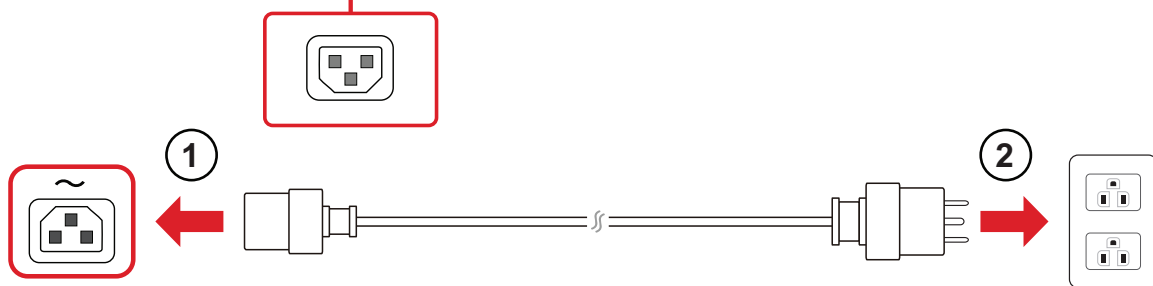
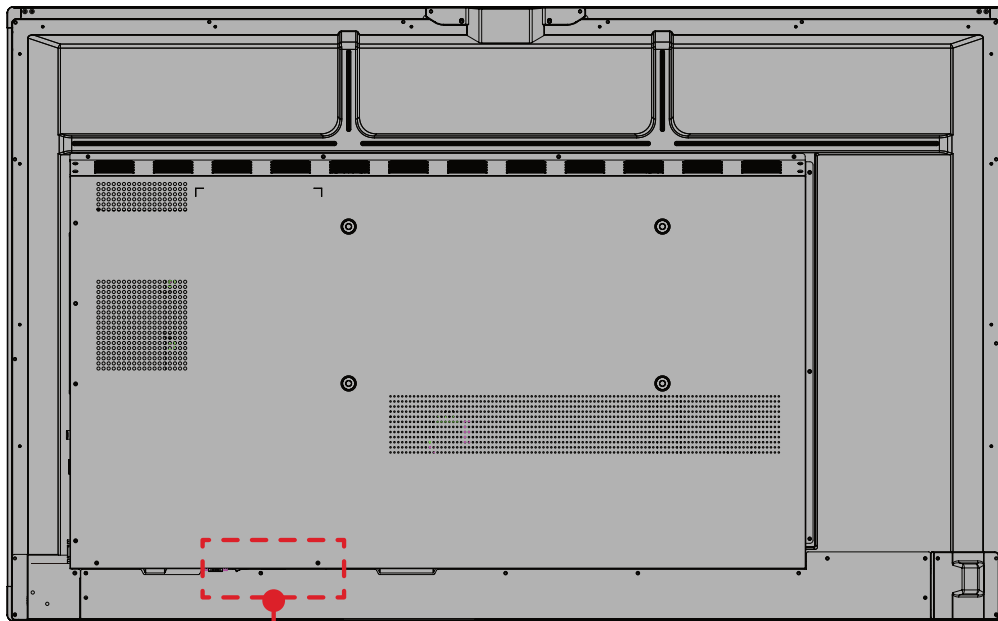

1. Connect the power cord to the **AC IN** jack at the rear of the display.
2. Plug the power cord plug into a power outlet.

# Connecting to Video Inputs and Enabling Touch

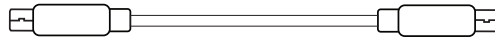
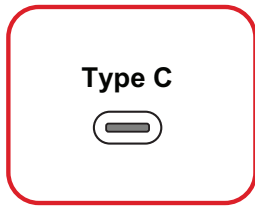

Or

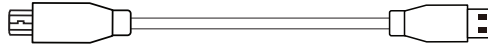
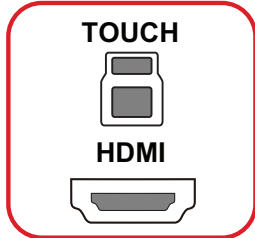

Or

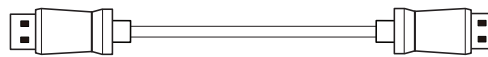
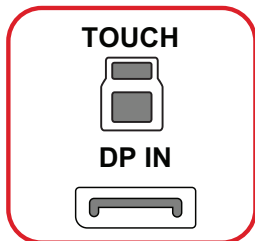

Or

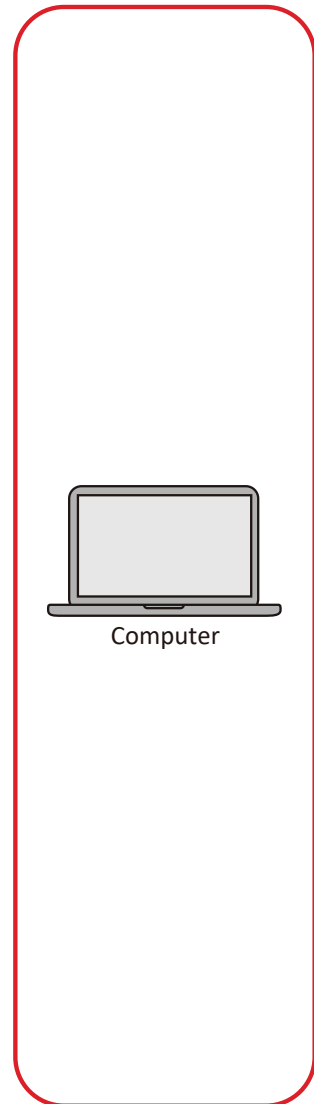
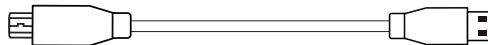
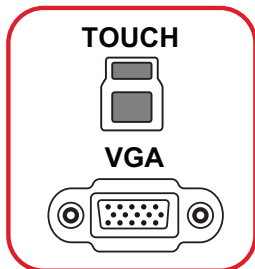

## USB Type C Connection

**Note:** When connecting the product through an extension device (e.g., docking station), USB 3.0/3.2 Gen 1 cables are recommended to ensure stable performance and proper functionality.

Connect a USB Type C cable from your external device to the USB Type C port on the display.

## HDMI Connection

1. Connect an HDMI cable from your external device to the **HDMI 1/HDMI 2/HDMI 3** port on the display.
2. Connect a USB Type B to A cable to your external device from the appropriate **TOUCH** port of the display.

## DisplayPort Connection

1. Connect a DisplayPort cable from your external device to the **DP IN** port on the display.
2. Connect a USB Type B to A cable to your external device from the **TOUCH 2** port of the display.

## VGA Connection

1. Connect a VGA cable from your external device to the **VGA** port on the display.
2. Connect a USB Type B to A cable to your external device from the **TOUCH 2** port of the display.

**Note:**

<b>TOUCH Port</b>	<b>Controls</b>
<b>TOUCH 1</b>	<b>HDMI 1</b>
<b>TOUCH 2</b>	<b>HDMI 2/DP IN/VGA</b>
<b>TOUCH 3</b>	<b>HDMI 3</b>

## RS-232 Connection



When you use a RS-232 serial cable to connect the display to an external computer or control system, certain functions can be controlled remotely such as: power on and off, volume adjustment, input select, brightness, and more.

## USB Connection

Just like any PC, it is easy to connect various USB devices and other peripherals to the display.

### USB Type A

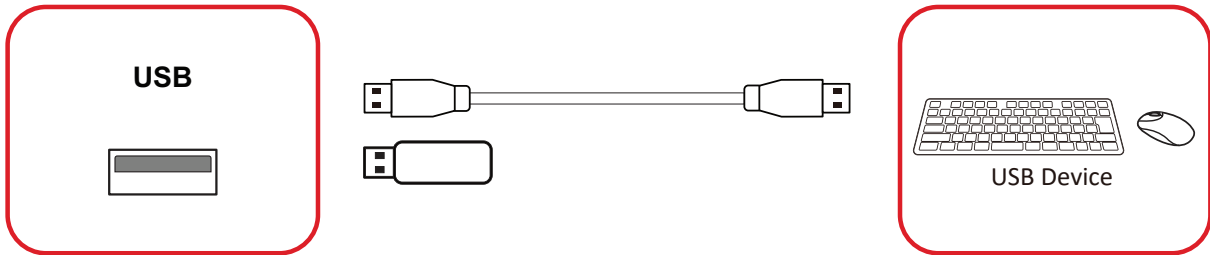

Plug the USB device or storage drive into a USB Type A port of the display.

### USB Type C

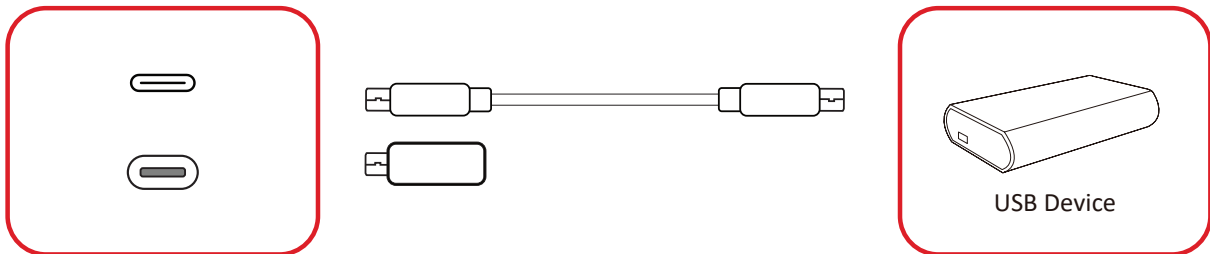

Plug the USB device or storage drive into the USB Type C port of the display.

## Network Connection



To connect to a local network, connect an Ethernet cable to your network, then connect the other end to the **LAN** port of the display.

## Media Connection

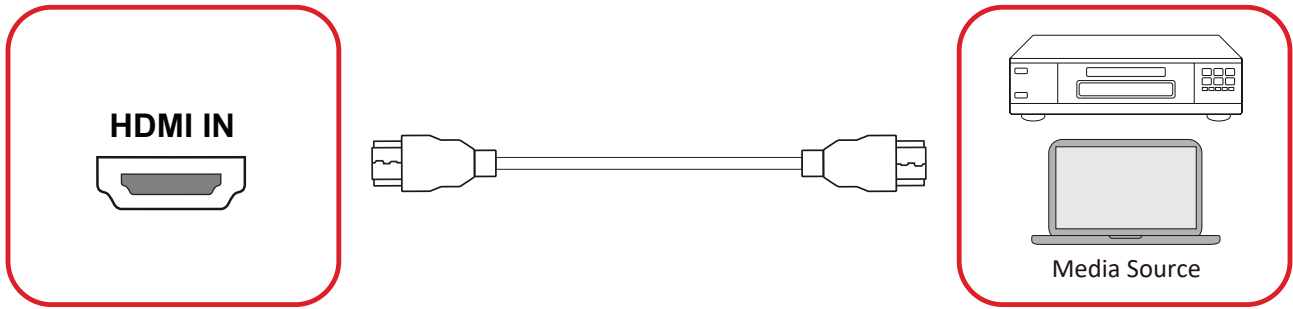

1. Connect an HDMI cable to an **HDMI** port on the display and peripheral device.
2. Press the **INPUT** button on the remote control and switch to the HDMI input source.

# Audio Connections

## Audio In



To play audio from your external device, connect one end of an audio cable to your external device, and the other end to the **AUDIO IN** port of the display.

## Audio Out



To play audio from the display through an external speaker, connect one end of an audio cable to the external speaker, and the other end to the **AUDIO OUT** port of the display.

## SPDIF

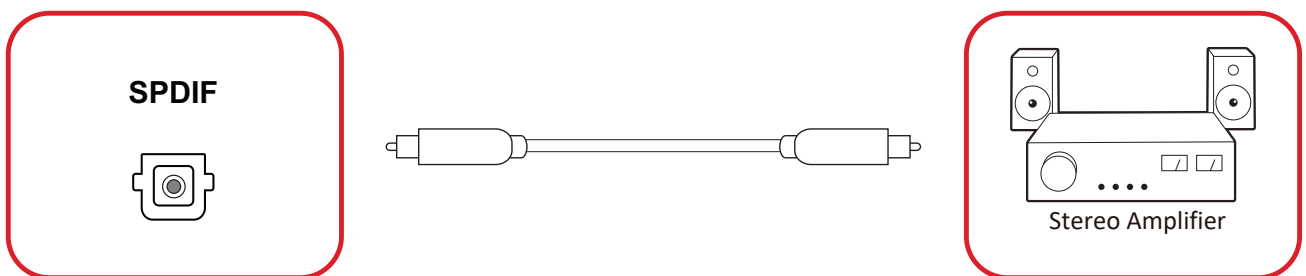

To connect to an external sound system, connect an optical cable from the display's **SPDIF** port to your sound system's optical connector.

## Video Output

### HDMI Out



1. Connect an HDMI cable to the HDMI IN port of your display device, then connect the other end to the **HDMI OUT** port of the display.
2. Press the **INPUT** button on the remote control and switch to the HDMI IN input source.

## Optional Connections

The display comes with an **OPS Slot** as well as a **Wi-Fi Slot** for optional add-ons such as a slot-in PC (e.g., VPC-35) or Wi-Fi card (e.g., VB-WIFI-004).

### Slot-in PC (OPS Slot) Installation

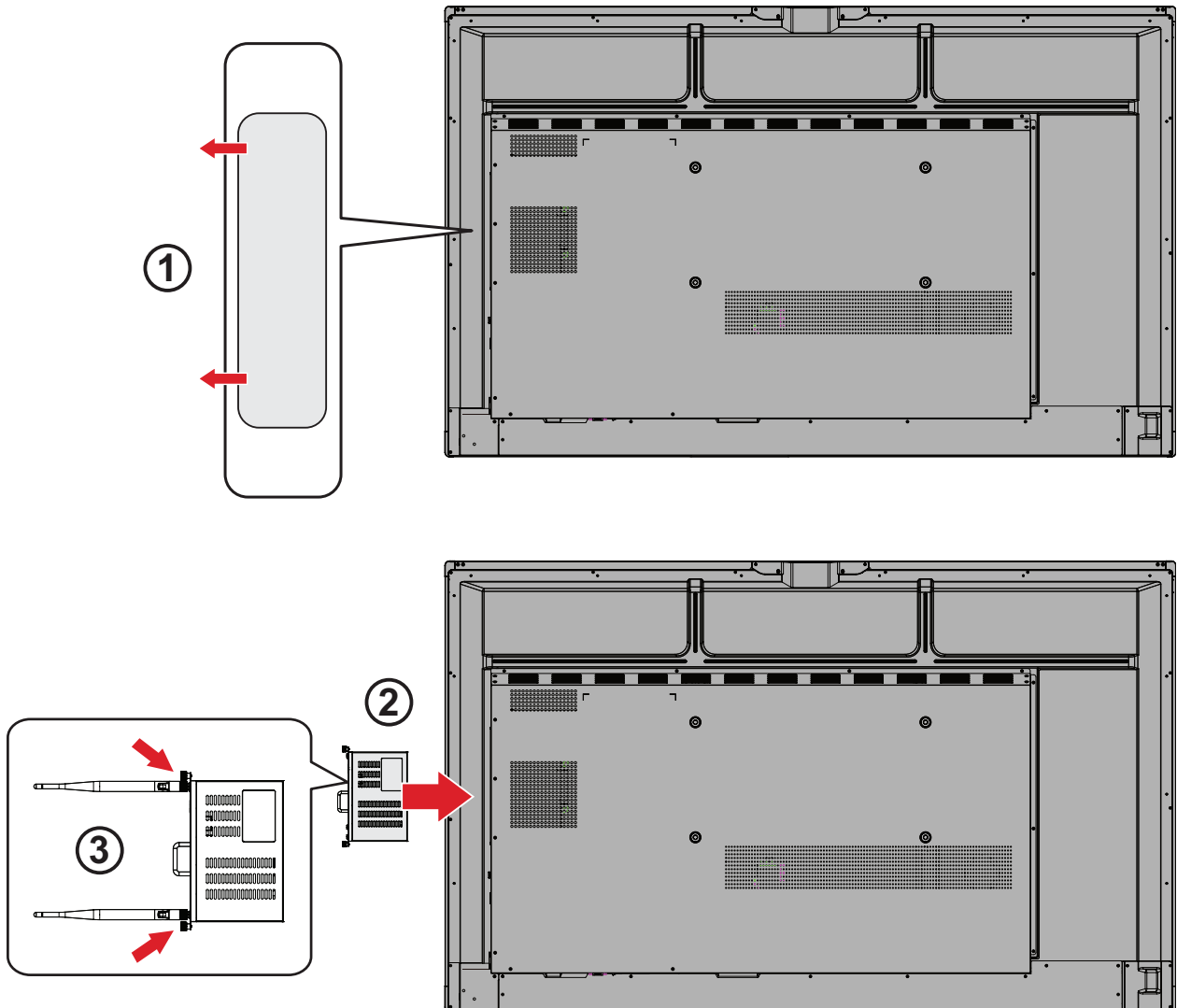

1. Remove the **OPS Slot** cover of the display.
2. Carefully insert the slot-in PC into the **OPS Slot** of the display.
3. Secure the slot-in PC to the display.

## Wi-Fi Card (Wi-Fi Slot) Installation

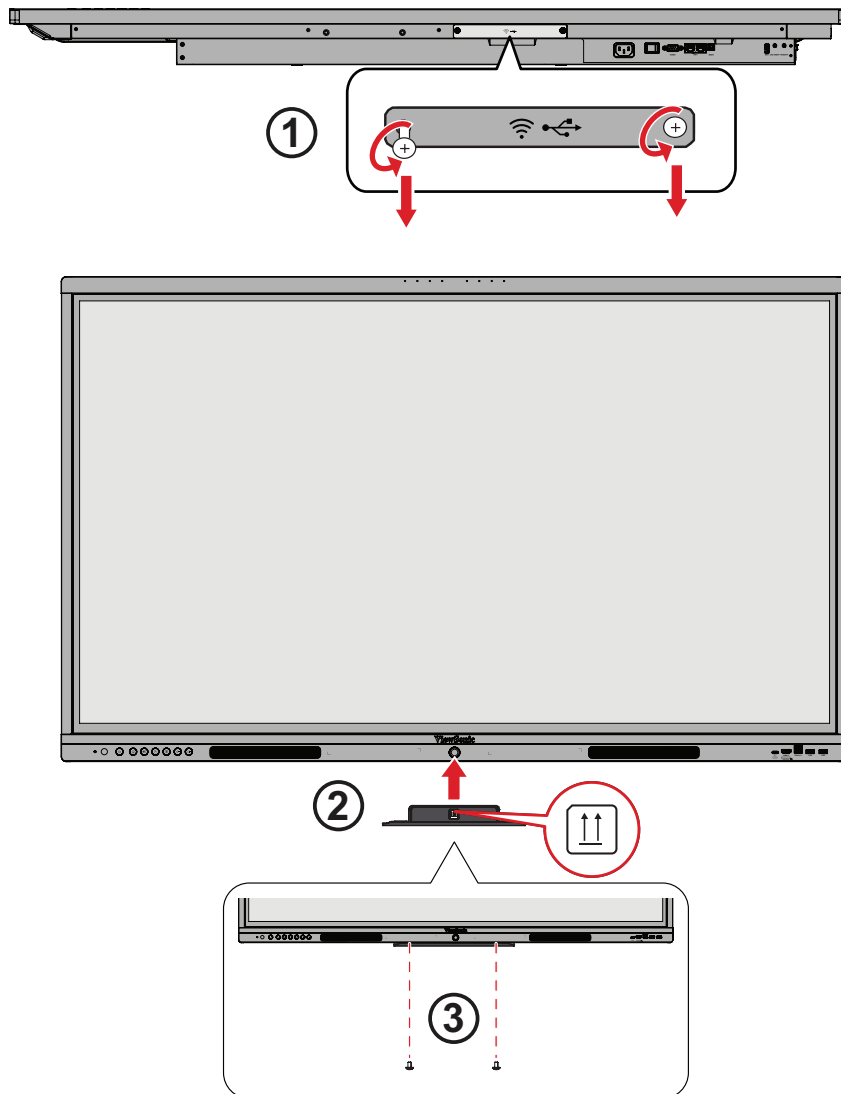

1. Remove the **Wi-Fi Slot** cover of the display.
2. Carefully insert the slot-in Wi-Fi card into the **Wi-Fi Slot** of the display.
3. Secure the slot-in Wi-Fi card to the display.

# Using the Display

## Turning the Display On/Off

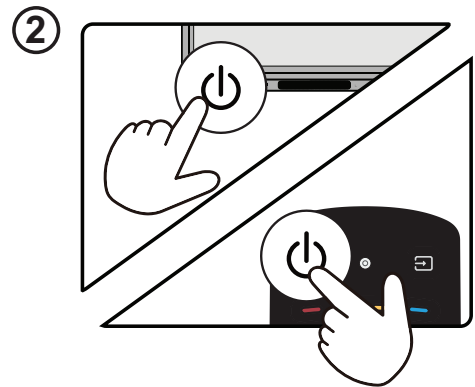
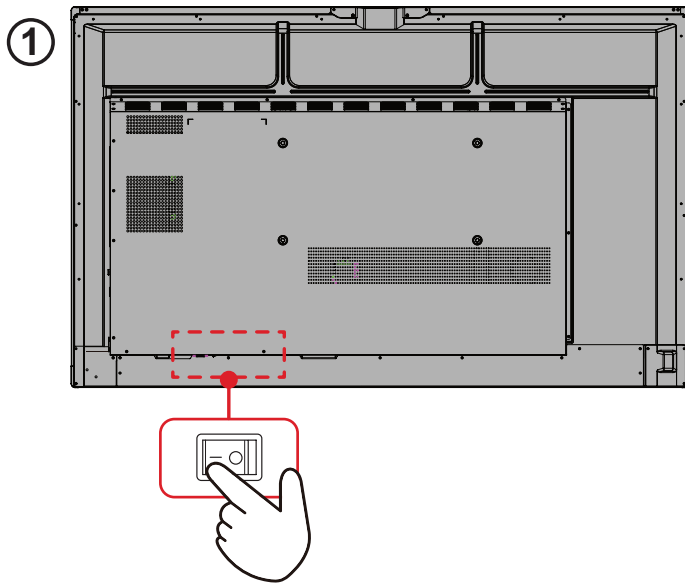

1. Make sure the power cord is connected, plugged into a power outlet, and the Power Switch is in the on position.
2. Press the **Power** button on the display or remote control to turn on the display.
3. To turn the display off, press and hold the **Power** button.

# Initial Launch Setup

When you first turn on your display, an initial setup wizard will launch.

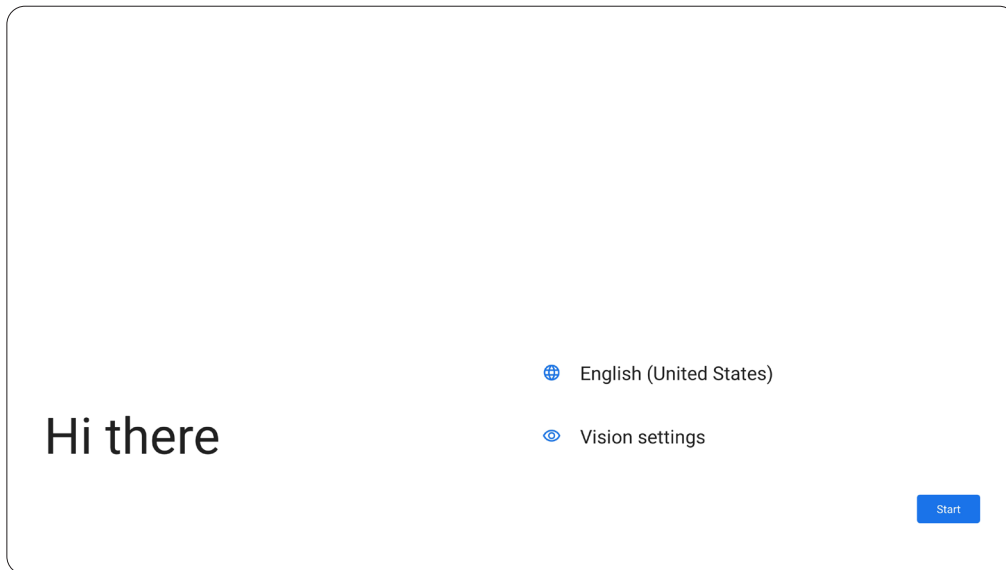

## 1. Choose your preferred Language.

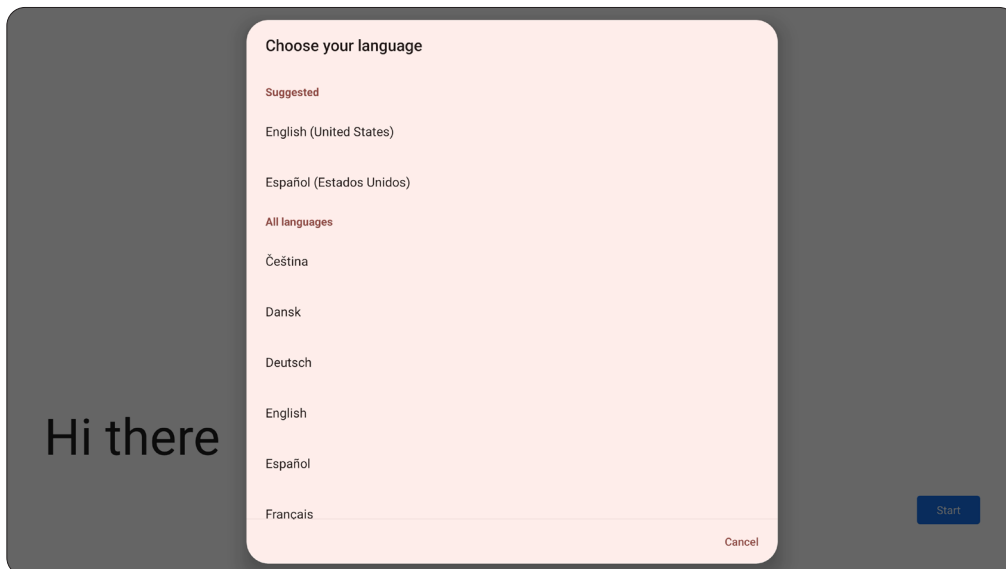

## 2. Adjust accessibility features as needed.

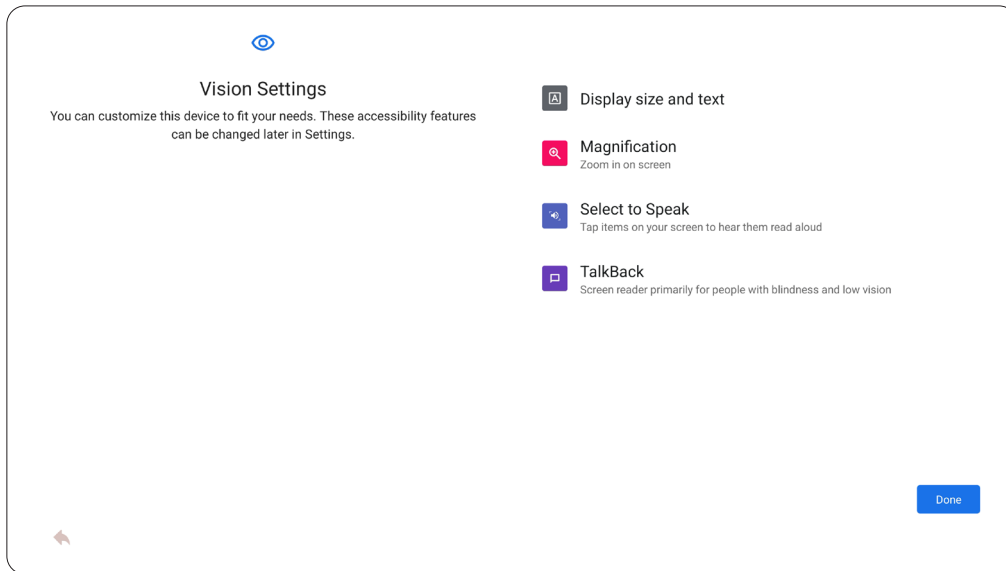

## 3. Setup and connect to a network.

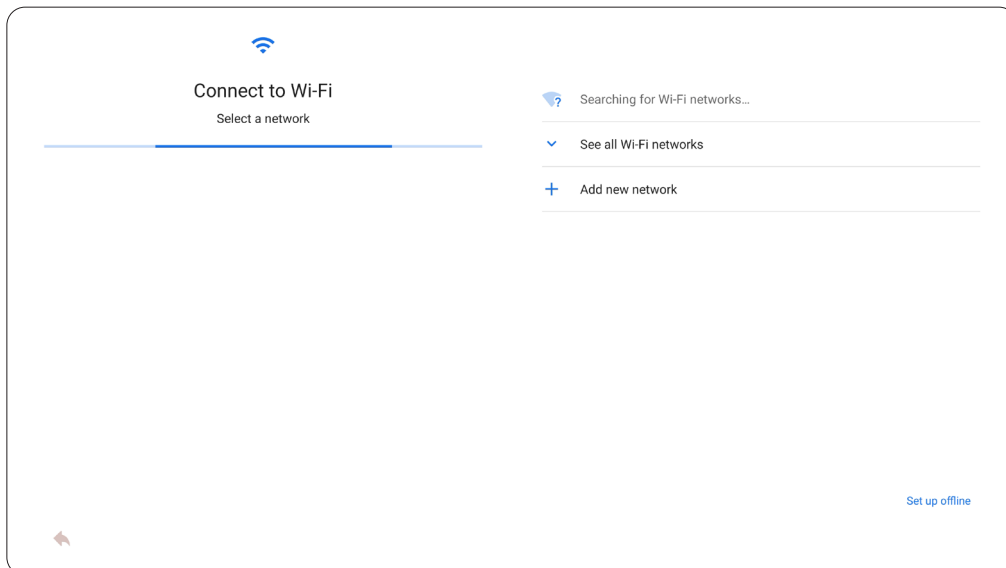

## 4. Set and adjust the Date and Time as needed.

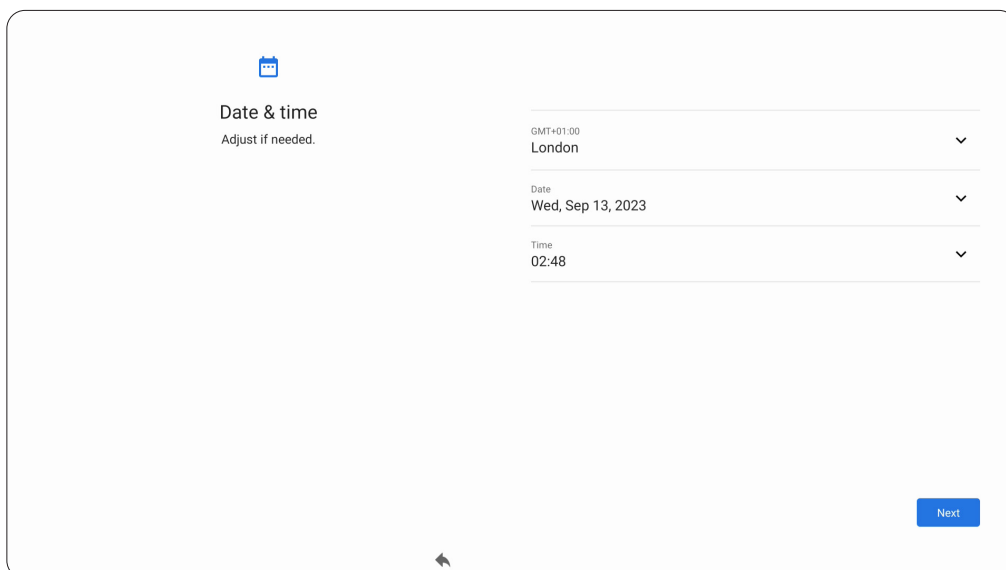

## 5. Copy your apps and data from another device to the display.

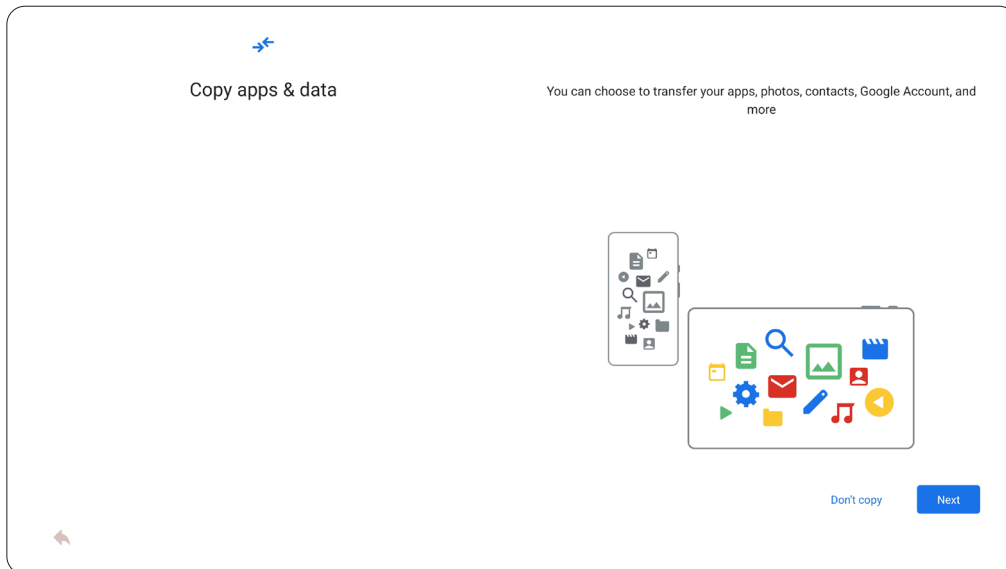

- If you want a fresh start, tap **Don't copy**.
- To start copying and transferring your apps and data, tap **Next**.
  - » If you use a USB cable to copy and transfer data, connect the cable to your devices and follow the on-screen directions to start transfer.
  - » If you don't have a cable, tap No cable? to start transfer wirelessly.

**Note:** Before starting, make sure your another device is connected to power, turned on, and unlocked.

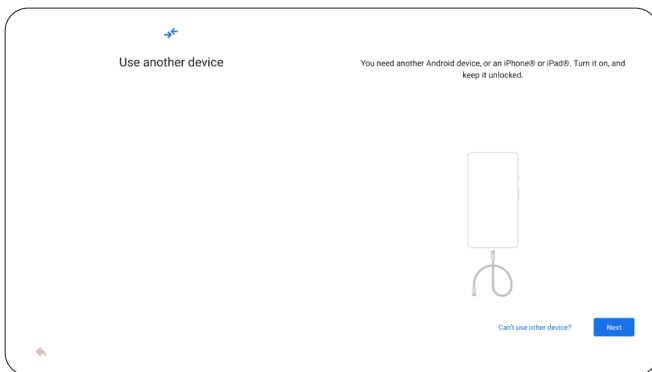

*Transferring data with a USB cable*

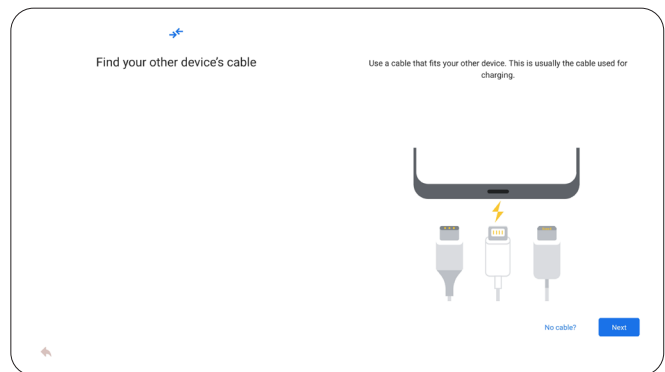

*Transferring data wirelessly*

## 6. Sign in with a Google account, or tap **Skip** to continue without signing in.

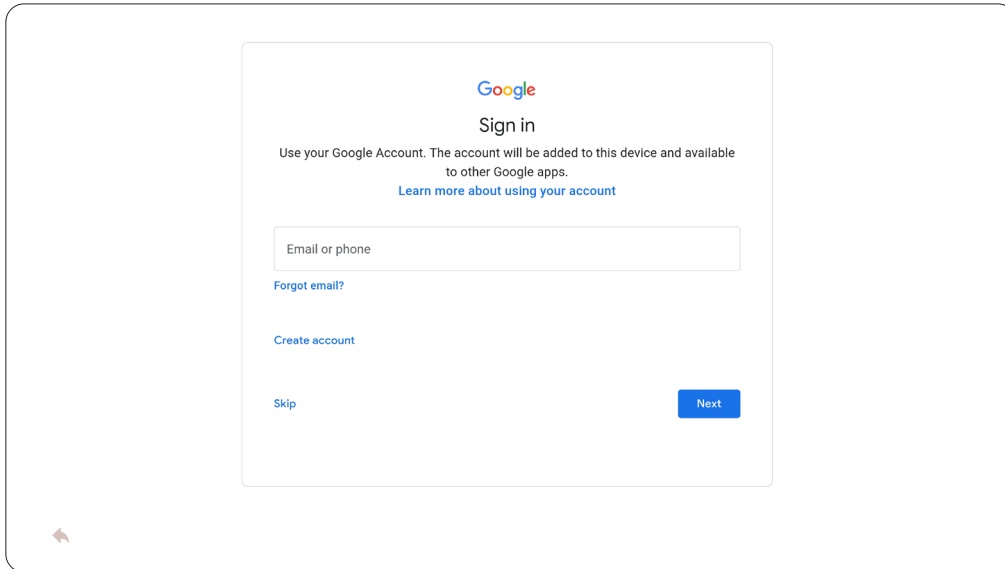

## 7. Accept or decline the Google services.

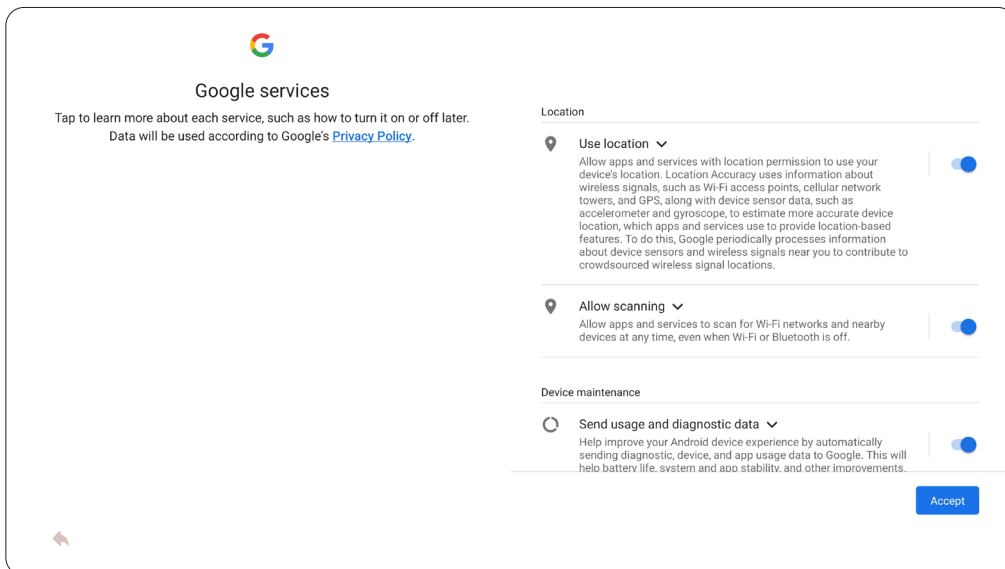

8. Set a PIN to setup a Screen lock. Then, tap **Next**, enter the PIN again, and tap **Confirm**.

**Note:** Personal Identification Number (PIN) helps prevent unauthorized use of the display. It is strongly recommended to set a pin for each of the owner profiles as only owners can manage access to the display(s) and more.

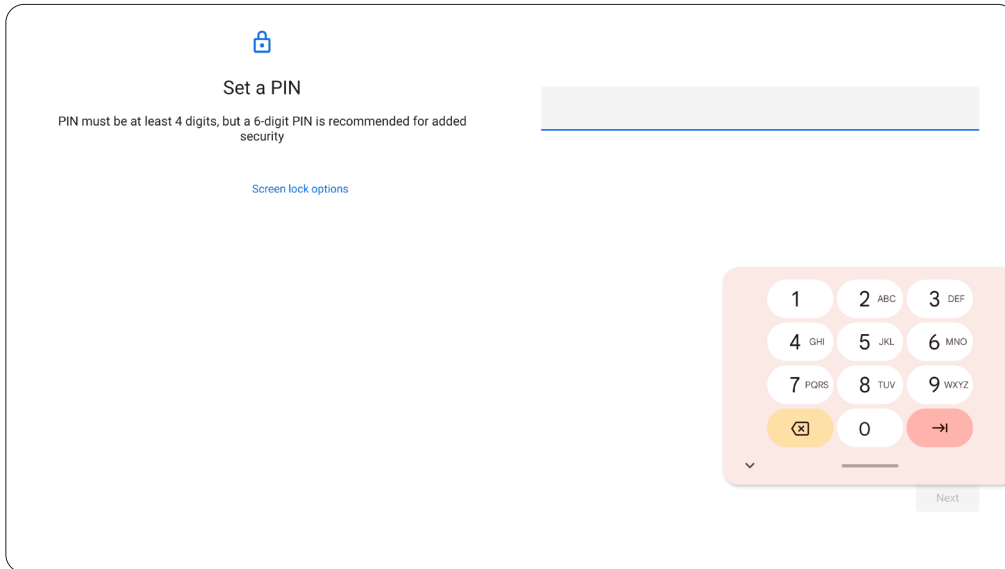

## 9. Select the preferred Operating System launcher.

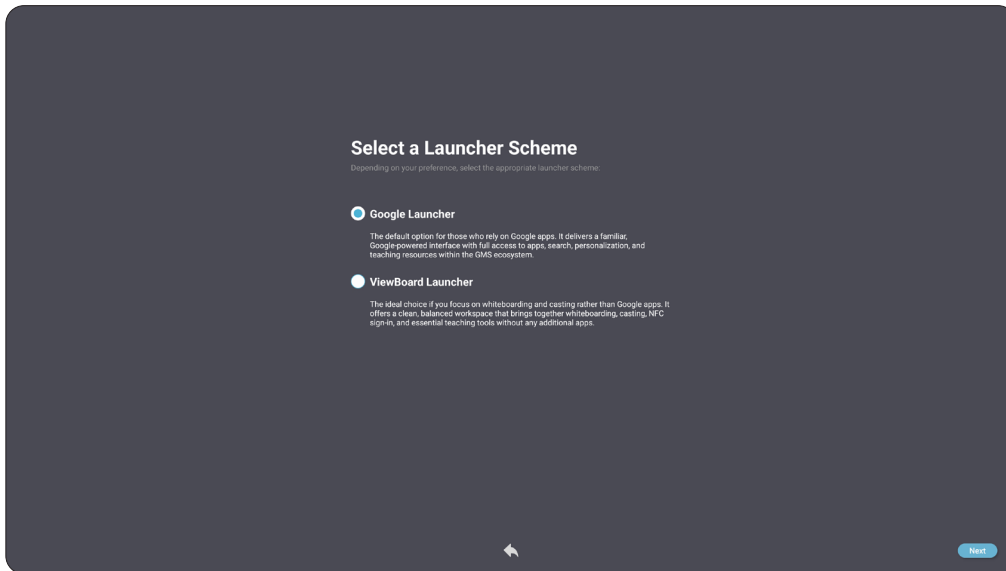

**Note:** You can always switch to the other launcher scheme later in the **System** settings.

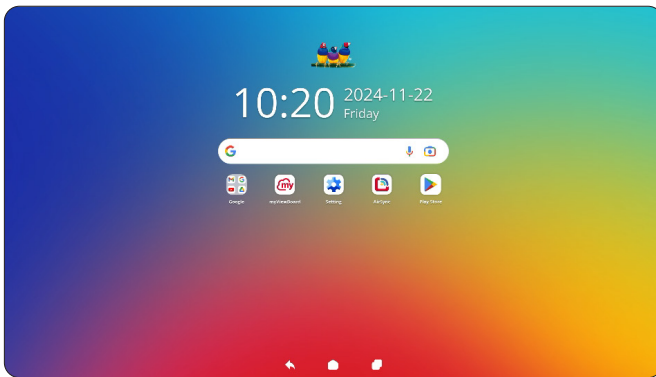

*Google Launcher (Scheme A)*

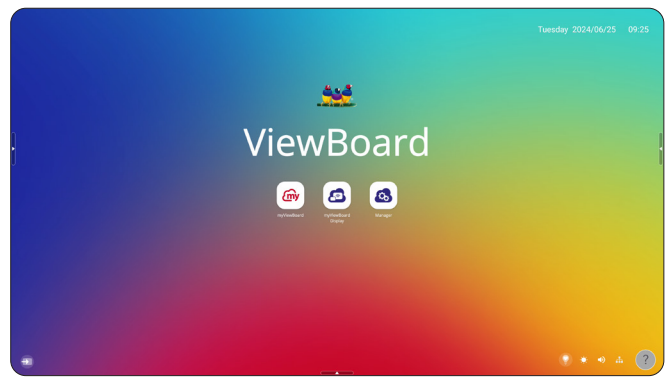

*ViewBoard Launcher (Scheme B)*

## 10. Select **Enable Manager** by granting **Device Owner** permission to confirm the ownership and gain access to the advanced features of the Manager application. Then, tap **Next**.

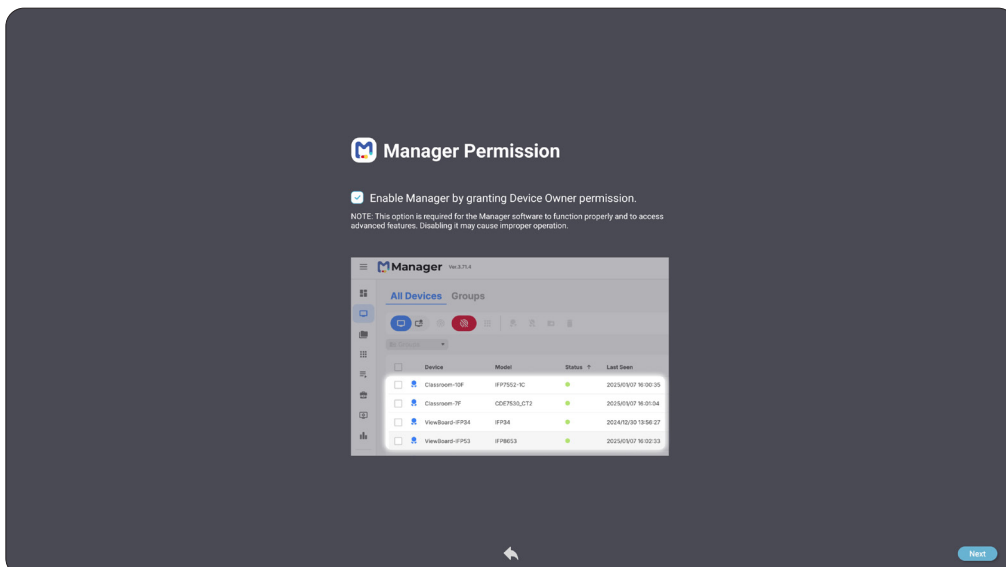

**11. Select the preferred boot up mode, then tap **Next**.**

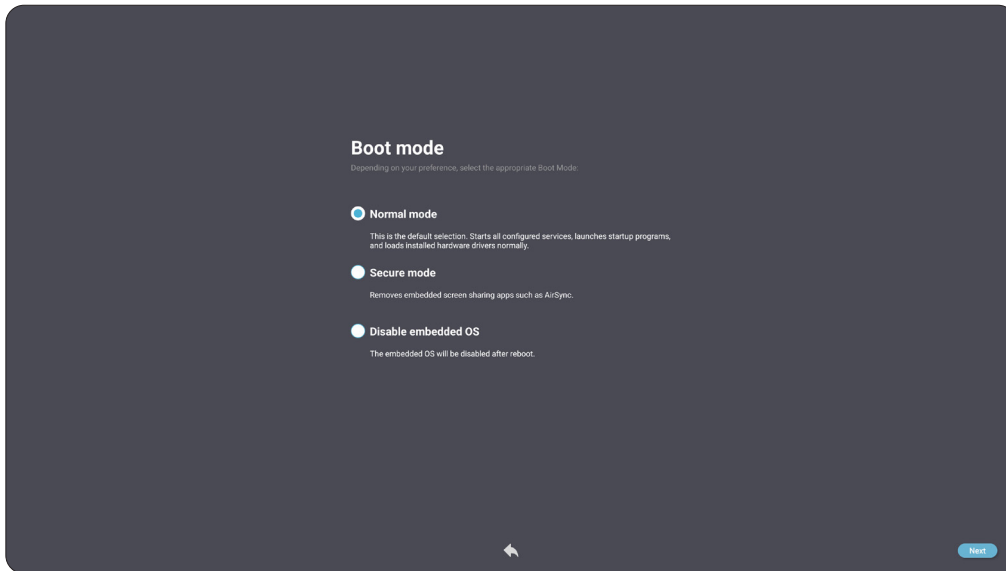

**12. Accept or decline the Privacy and Copyright Protection terms. Then, tap **Finish** to complete the initial setup.**

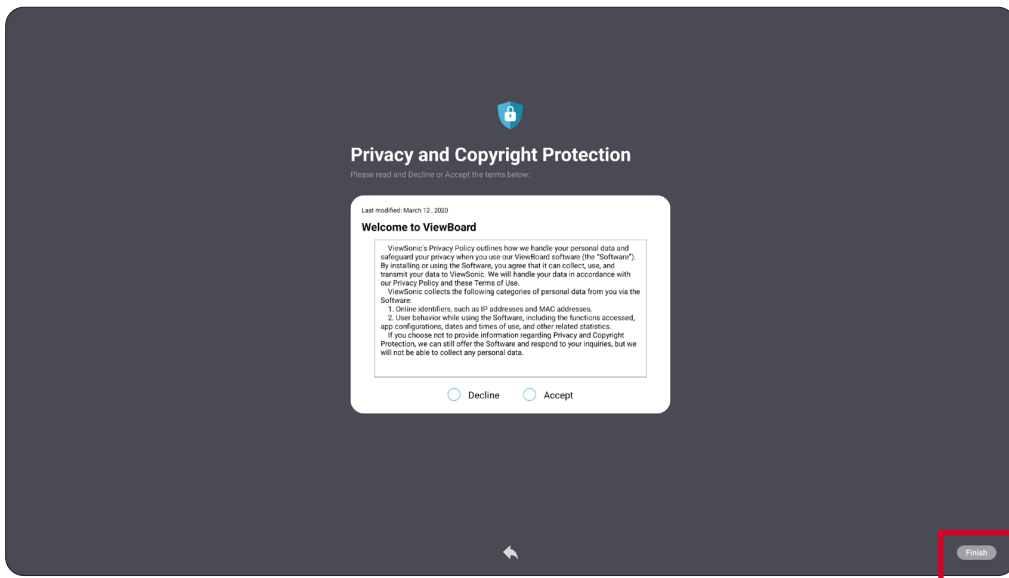

# Sign-in Screen

**Note:** The Sign-in Screen will appear if Guest Mode is disabled, or by selecting the sign-in button under Guest Mode.

Enter your email address and password, then select **Sign In**. Alternatively, you can use single sign-on (SSO) or Companion Sign-in via QR code.

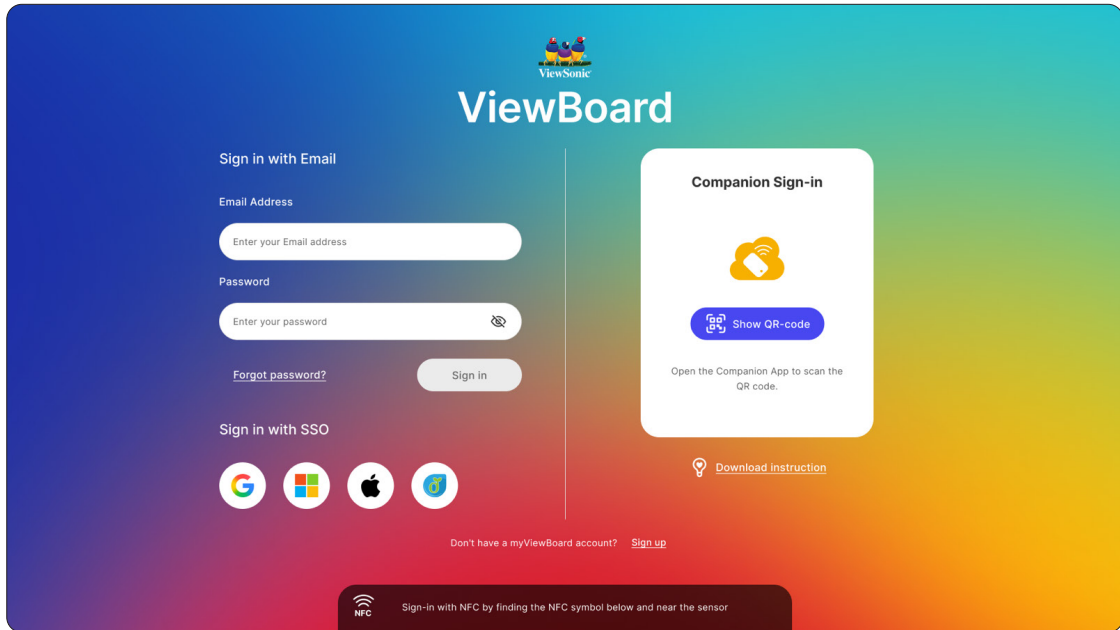

# How to Sign Up

Select the **Sign Up** button at the bottom of the screen, then scan the QR code and follow the directions to sign in.

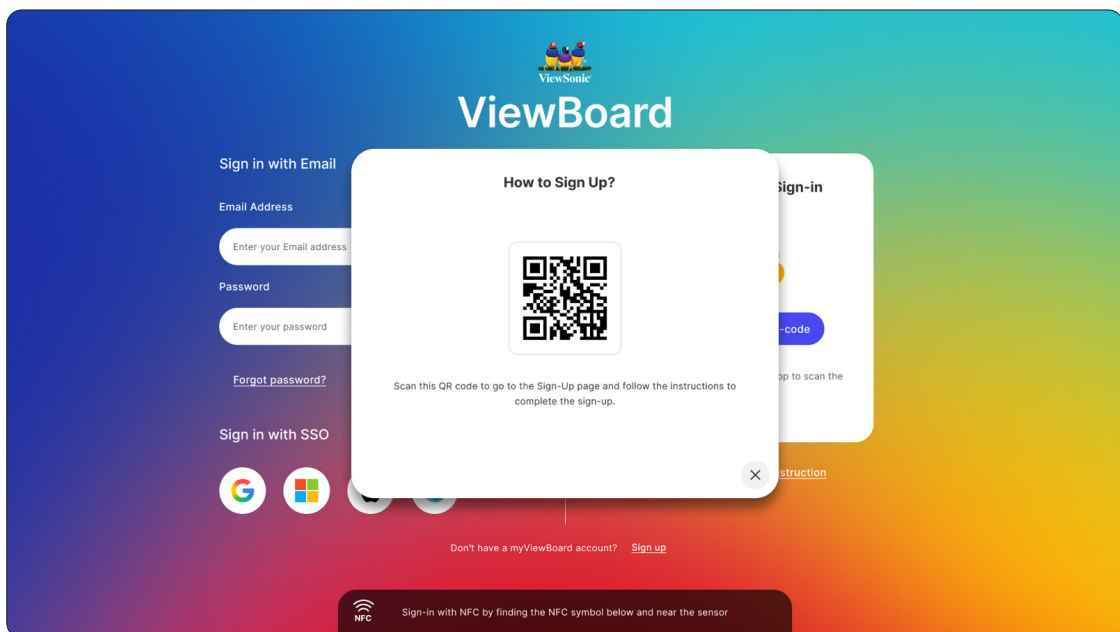

## Guest Mode

When Guest Mode is enabled, the Home Screen will open directly without requiring sign-in.

**Note:** Please note that user settings cannot be saved when using Guest Mode.

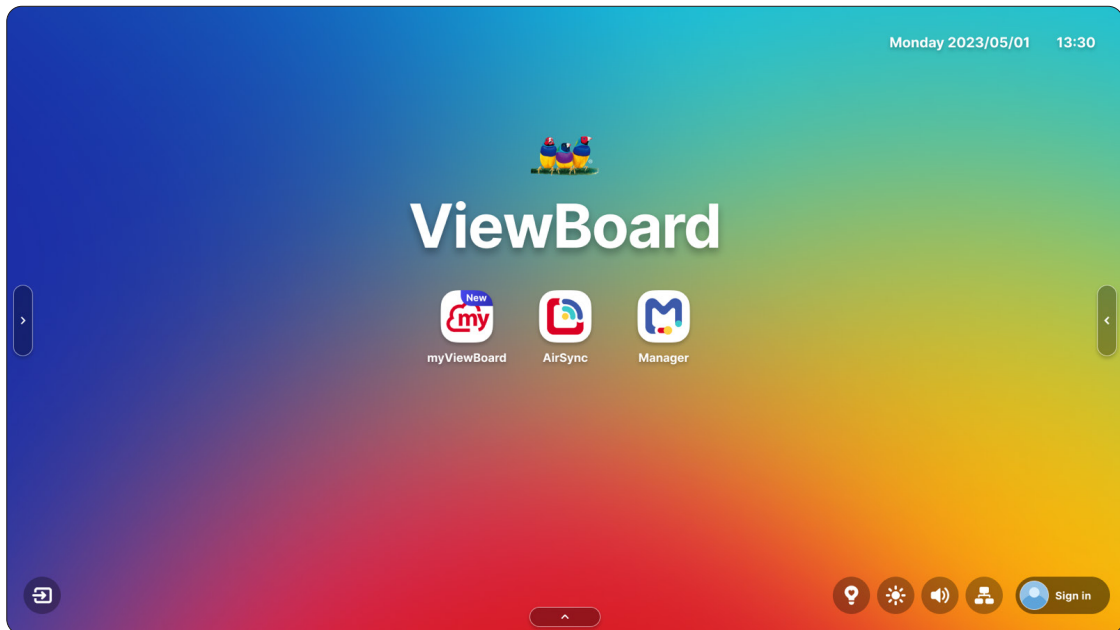

## Sign In

Select the **Sign In** button to sign in.

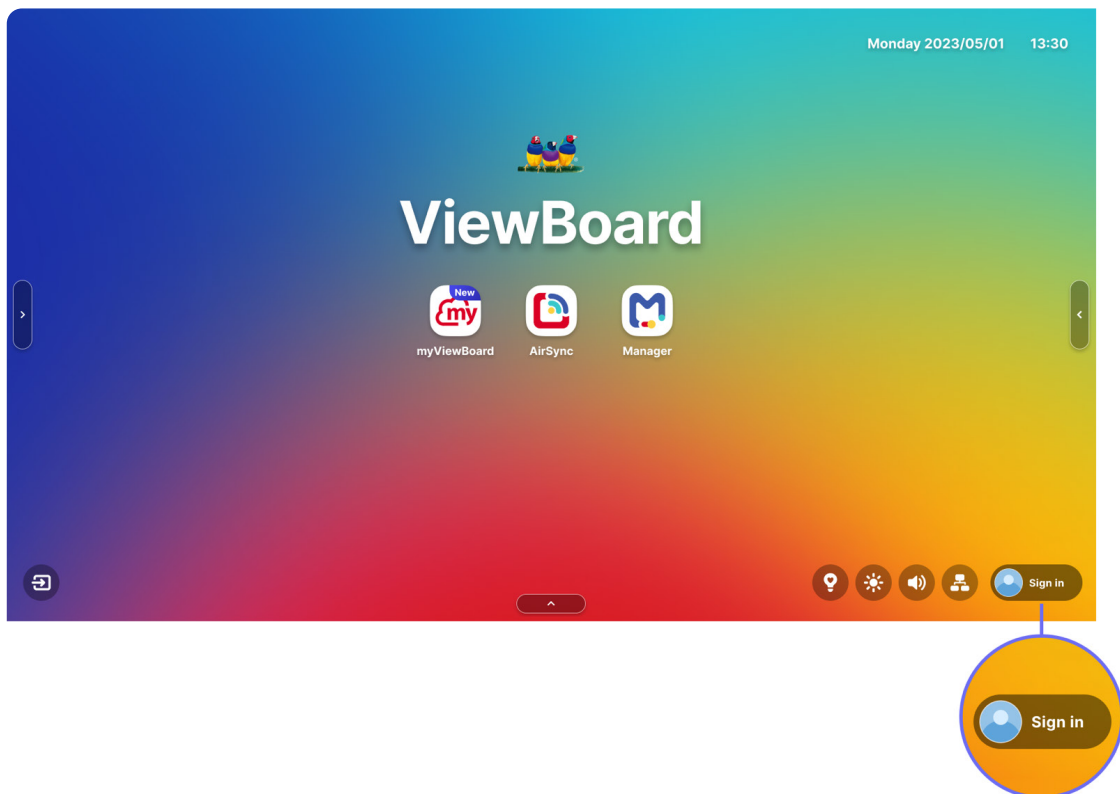

# Home Screen

## Home Screen Message

The Home Screen message can be edited by selecting it directly on the Home Screen.

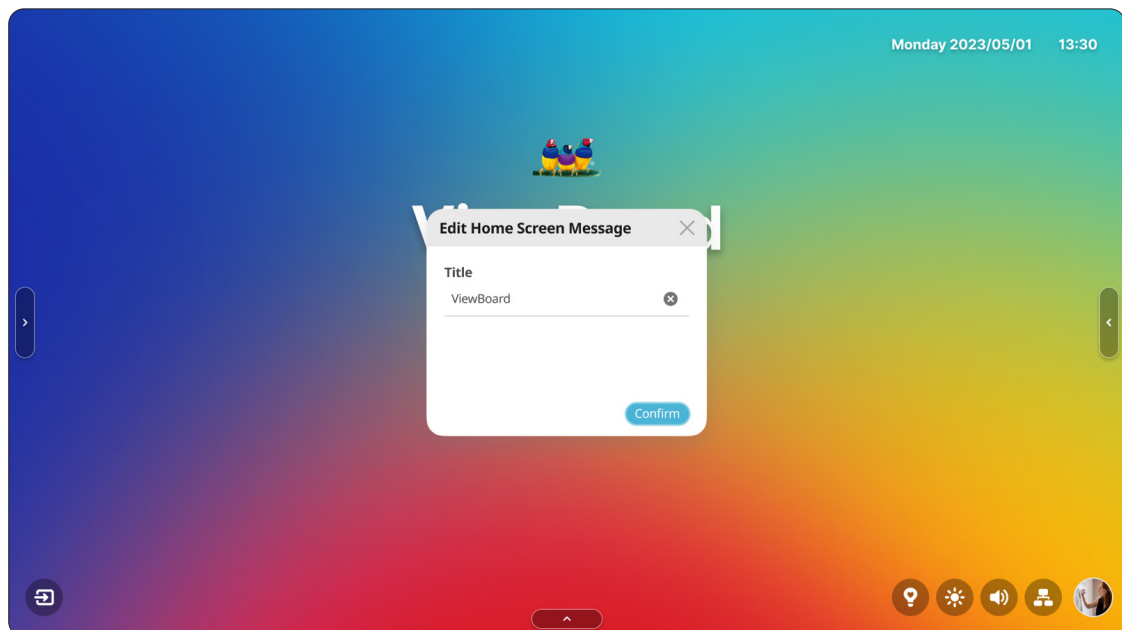

## Toolbar

The Toolbar is where applications and tools can be found. Trigger icons are on the right, left, and bottom edge of the screen for quick access.

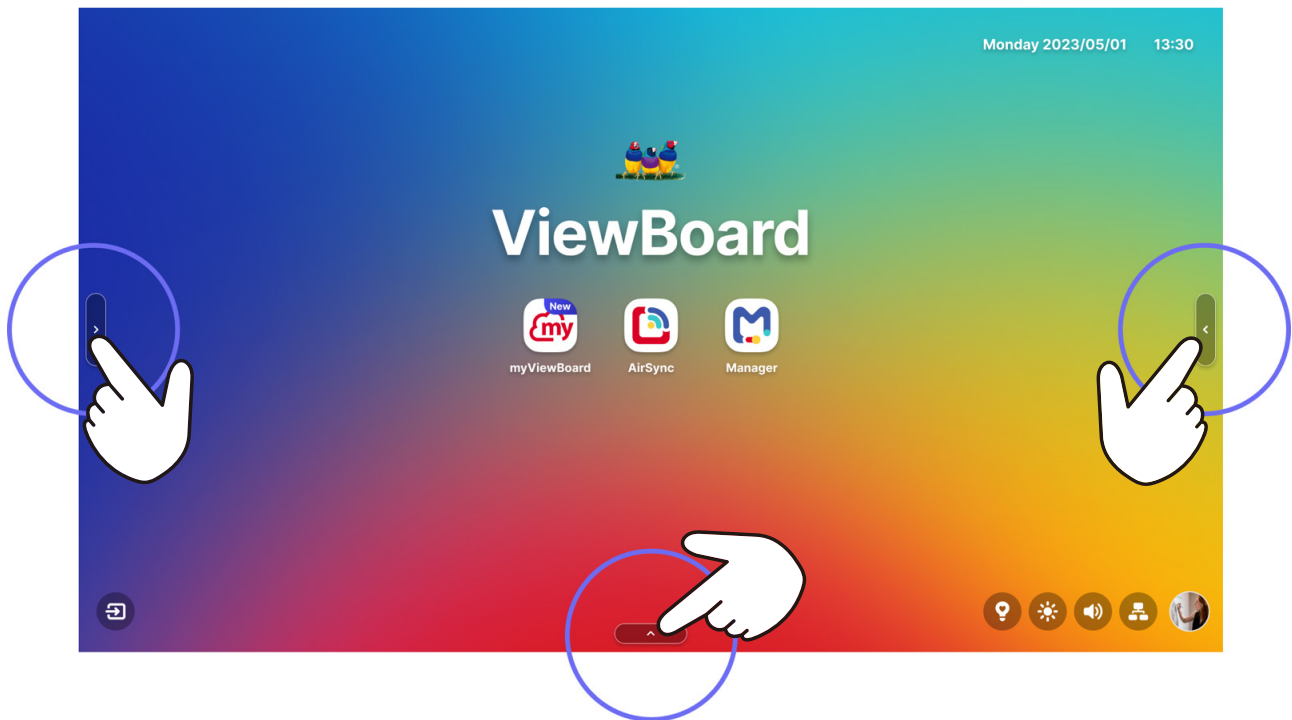

To launch an application or tool:









1. Tap a Toolbar trigger icon.
2. Tap an application or tool.

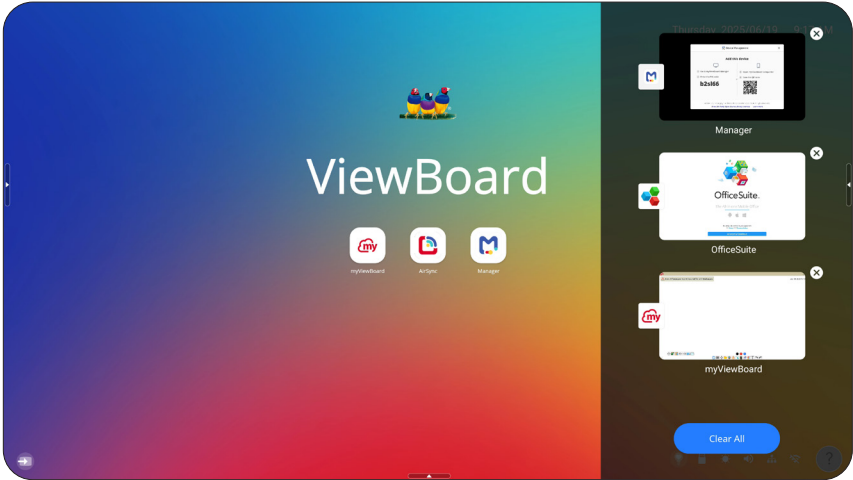

**Note:** The default Toolbar setting is to be available for all input sources; however, users can go to: **Settings > Preference > Toolbar settings** to adjust the options: (1) Show side Toolbar, (2) Hide side toolbar, (3) Disable in all input sources.



## Toolbar Icons



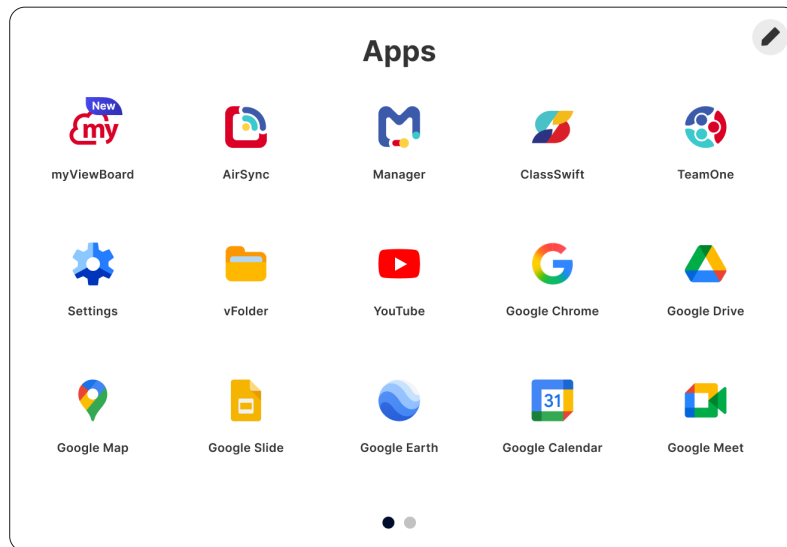

Icon	Description
 <p><b>Return</b></p>	<p>Return to the previous operation screen.  <b>Note:</b> Only for the display source.</p>
 <p><b>Home</b></p>	<p>Return to the Home Screen.</p>
 <p><b>Recent</b></p>	<p>Display all currently open applications.</p>  <p><b>Note:</b> Selecting the “X” will close the application.</p>
 <p><b>Applications</b></p>	<p>View all installed applications.</p>
 <p><b>vFolder</b></p>	<p>Browse and open files.</p>
 <p><b>Tools</b></p>	<p>Quickly view and adjust various frequently used tools.</p>
 <p><b>Annotation</b></p>	<p>Annotate, highlight, and more.</p>
 <p><b>Input Source</b></p>	<p>Select and change the input source signal.</p>

# Applications

Applications can be accessed from the Toolbar, from the Home Screen using shortcuts, or by selecting the **Applications** icon.



**Note:** The following included application descriptions are not a comprehensive list and will vary by the user.

Icon	Description
 <b>AirSync</b>	Wirelessly mirror screens to a larger display.
 <b>Manager</b>	Remotely manage multiple installations of ViewSonic devices.
 <b>myViewBoard</b>	A digital whiteboarding application.
 <b>Settings</b>	Access the <b>System</b> settings.

# On-Screen Display (OSD) Menu - General Settings

Access **Input**, **Display**, and other general settings through the OSD Menu.

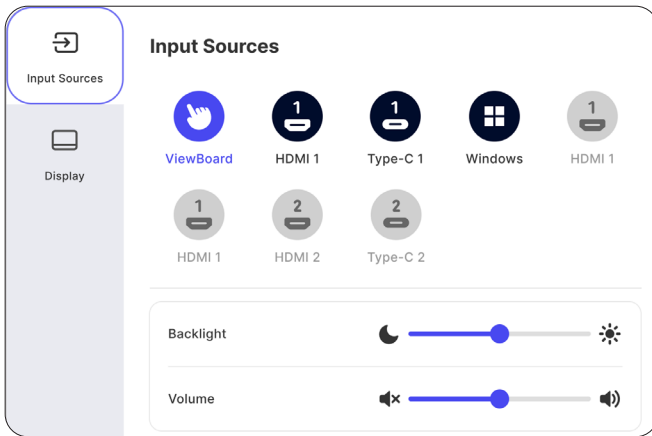

*Input Settings*

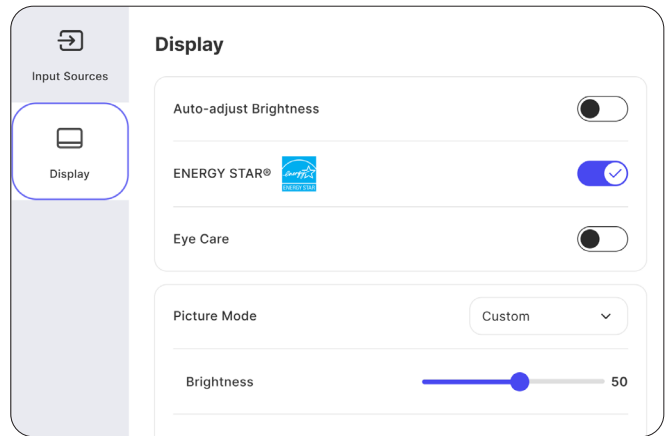

*Display Settings*

Open the OSD Menu by pressing **INPUT** on the remote control or tapping the **Input Source** icon.

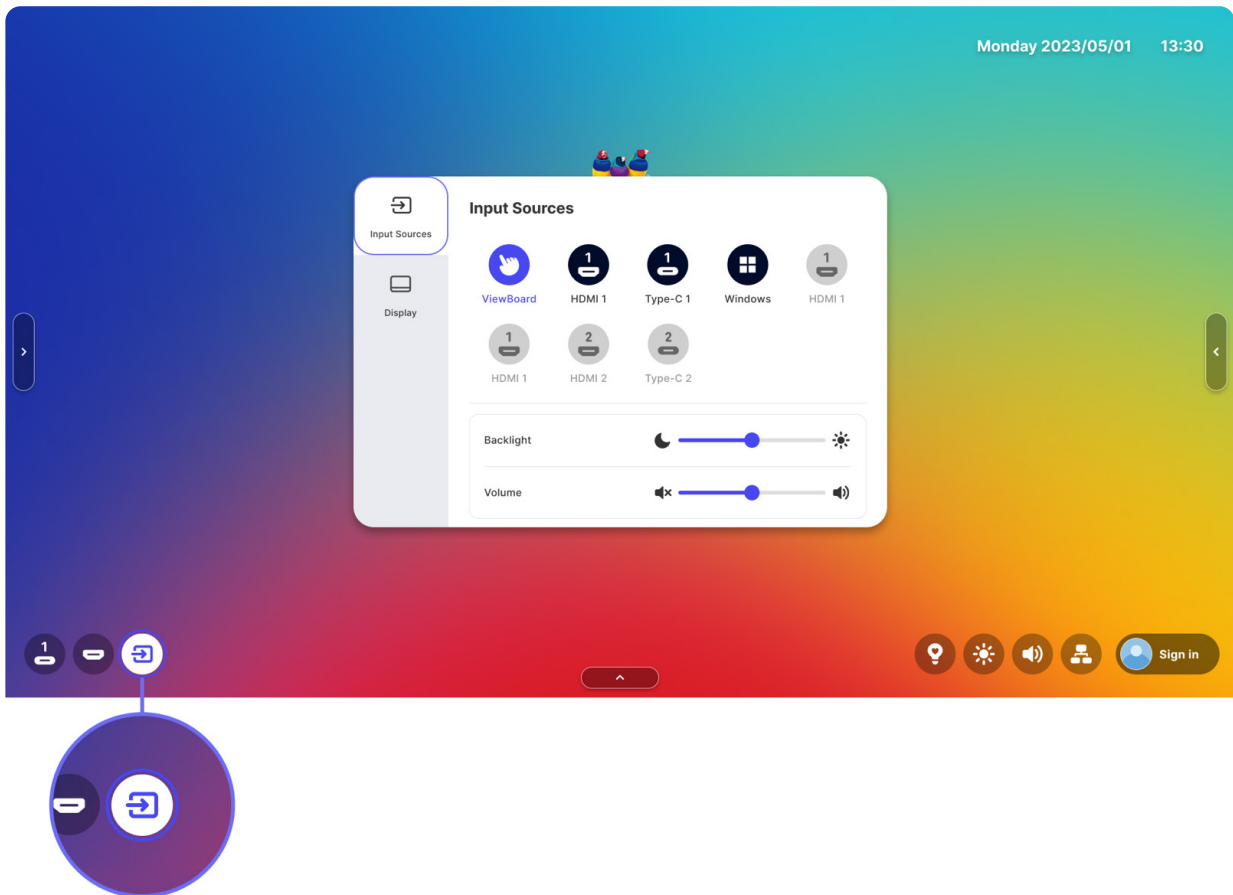

The **Input Settings** can also displayed by tapping the signal source icon.

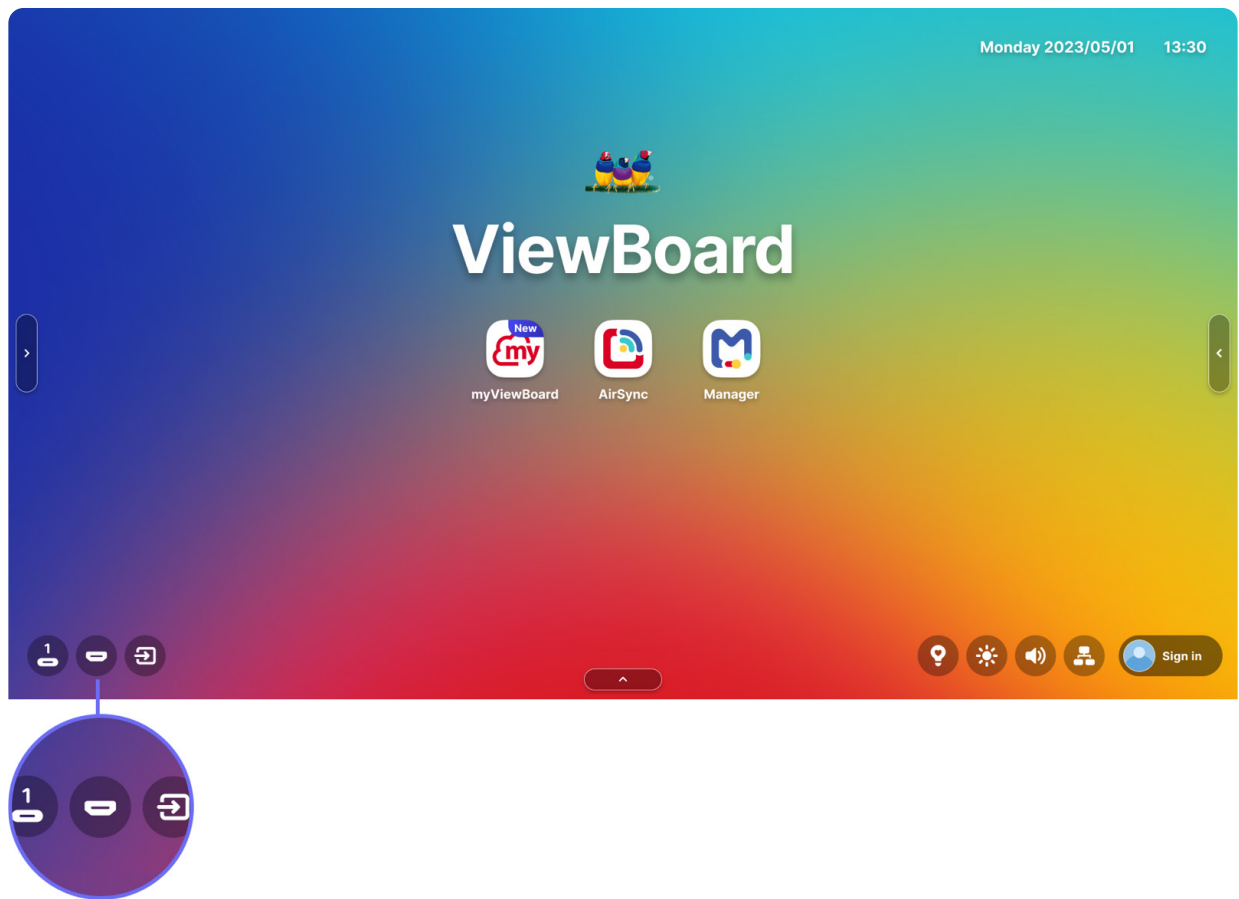

## Input Settings

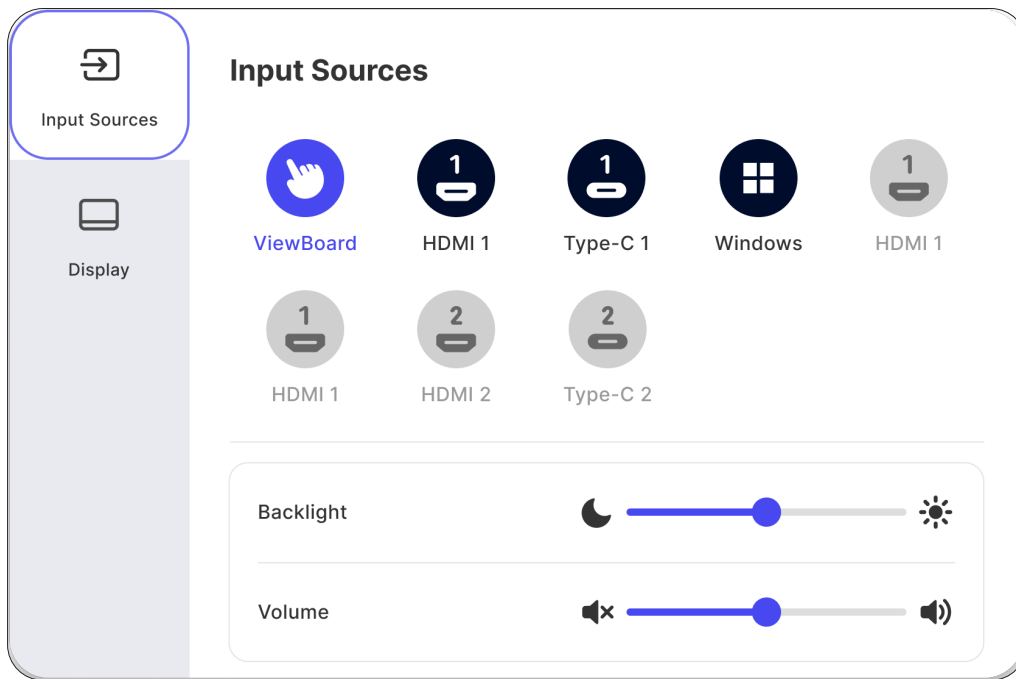

To select an input source:

1. Press **INPUT** on the remote control or tap the **Input Source** icon to display the **Input Settings** menu.
2. Press the **Navigation** buttons (**↑/↓/←/→**) on the remote control to select the input source you want.

**Note:** The PC source will only be visible when a slot-in computer is installed.

3. Press **ENTER** on the remote control, or tap the desired input source.
4. Press **BACK** on the remote control, or tap a blank area outside of the menu to exit.

To adjust the brightness:

1. Press **INPUT** on the remote control or tap the **Input Source** icon to display the **Input Settings** menu.
2. Drag the brightness slider directly to adjust the backlight value.
3. Press **BACK** on the remote control, or tap a blank area outside of the menu to exit.

To adjust the volume:

1. Press **INPUT** on the remote control or tap the **Input Source** icon to display the **Input Settings** menu.
2. Drag the volume slider directly to adjust the value, or press the **Volume** buttons on the remote control to adjust. Additionally, pressing **Mute** on the remote control will mute/unmute the volume.
3. Press **BACK** on the remote control, or tap a blank area outside of the menu to exit.

# Display Settings

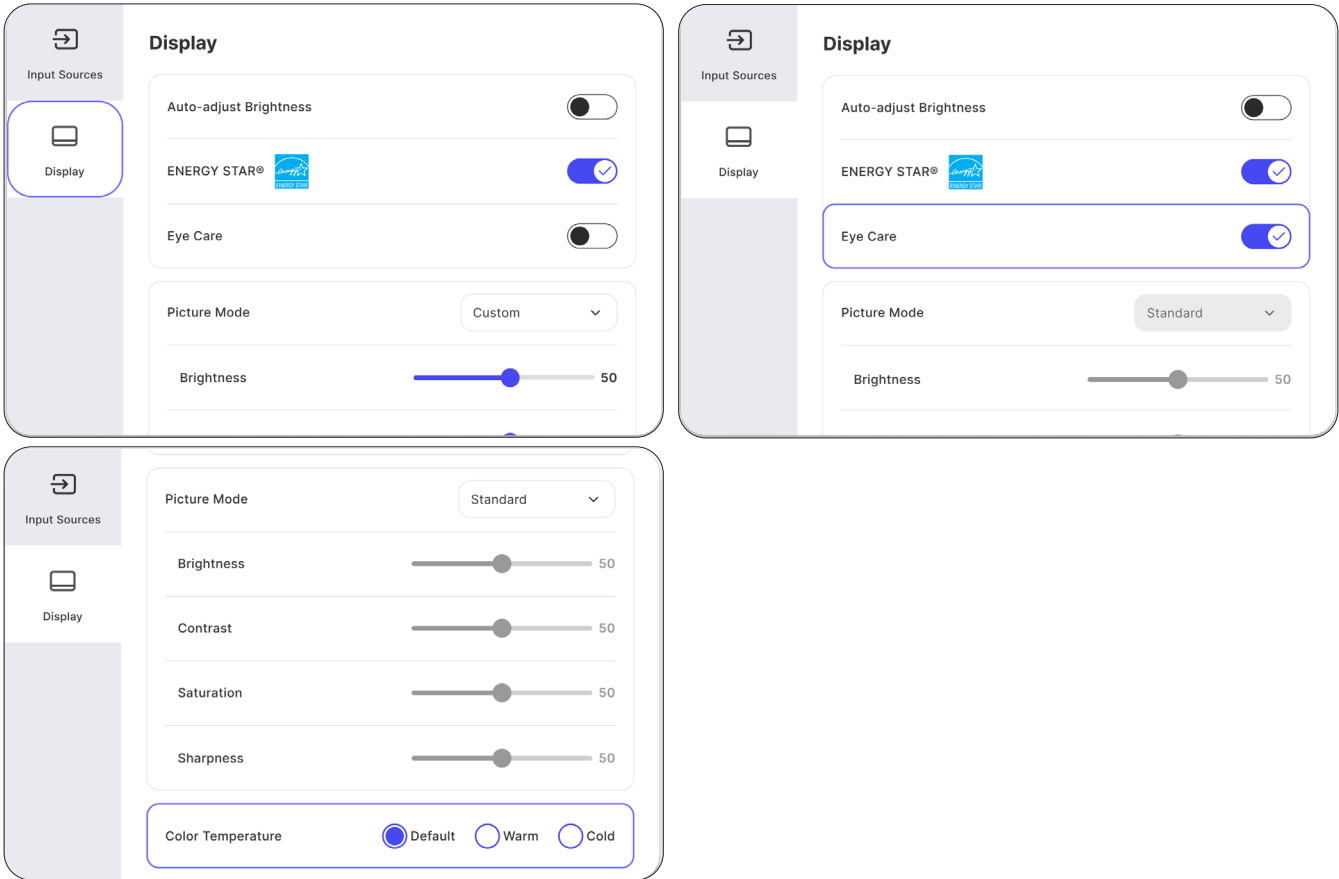

To adjust the display settings:

1. Press **INPUT** on the remote control or tap the **Input Source** icon to display the **Input Settings** menu. Then select the **Display** tab.
2. Press the **Navigation** buttons (**↑/↓/←/→**) on the remote control to select the menu option you want.
3. Press **ENTER** on the remote control to confirm or press the **Navigation** buttons (**←/→**) to adjust the menu option. Additionally, tap/adjust the menu option directly.
4. Press **BACK** on the remote control, or tap a blank area outside of the menu to exit.

## Display Settings - Menu Options

Item	Description										
<b>Auto Brightness</b>	Automatic brightness adjustment. Adjusts maximum brightness according to ambient light levels.										
<b>Energy Saving</b>	Enable to reduce power consumption.										
<b>Eye Care</b>	Adjusts the filter that blocks high-energy blue light for a more comfortable viewing experience.										
<b>Picture Mode</b>	Select a predefined picture setting.										
	<table border="1"> <thead> <tr> <th>Mode</th> <th>Description</th> </tr> </thead> <tbody> <tr> <td><b>Standard</b></td> <td>Default picture mode.</td> </tr> <tr> <td><b>Bright</b></td> <td>Maximizes the brightness of the display. This mode is suitable for environments where extra-high brightness is required (e.g., well-lit rooms).</td> </tr> <tr> <td><b>Soft</b></td> <td>A high brightness level with lower contrast level.</td> </tr> <tr> <td><b>Custom</b></td> <td>Customize the picture settings.</td> </tr> </tbody> </table>	Mode	Description	<b>Standard</b>	Default picture mode.	<b>Bright</b>	Maximizes the brightness of the display. This mode is suitable for environments where extra-high brightness is required (e.g., well-lit rooms).	<b>Soft</b>	A high brightness level with lower contrast level.	<b>Custom</b>	Customize the picture settings.
	Mode	Description									
	<b>Standard</b>	Default picture mode.									
	<b>Bright</b>	Maximizes the brightness of the display. This mode is suitable for environments where extra-high brightness is required (e.g., well-lit rooms).									
<b>Soft</b>	A high brightness level with lower contrast level.										
<b>Custom</b>	Customize the picture settings.										
<b>Brightness</b>	Adjust the background black levels of the screen.										
<b>Contrast</b>	Adjusts the difference between the image background (black level) and the foreground (white level). Use this to set the peak white level after you have previously adjusted the <b>Brightness</b> setting to suit your selected input and viewing environment.										
<b>Saturation</b>	Adjust the amount of color present.										
<b>Sharpness</b>	A high value results in a sharper picture; a low value softens the picture.										
<b>Color Temperature</b>	Adjust the color temperature value.										

## Eye Care

Eye Care blocks high-energy blue light for a more comfortable viewing experience.

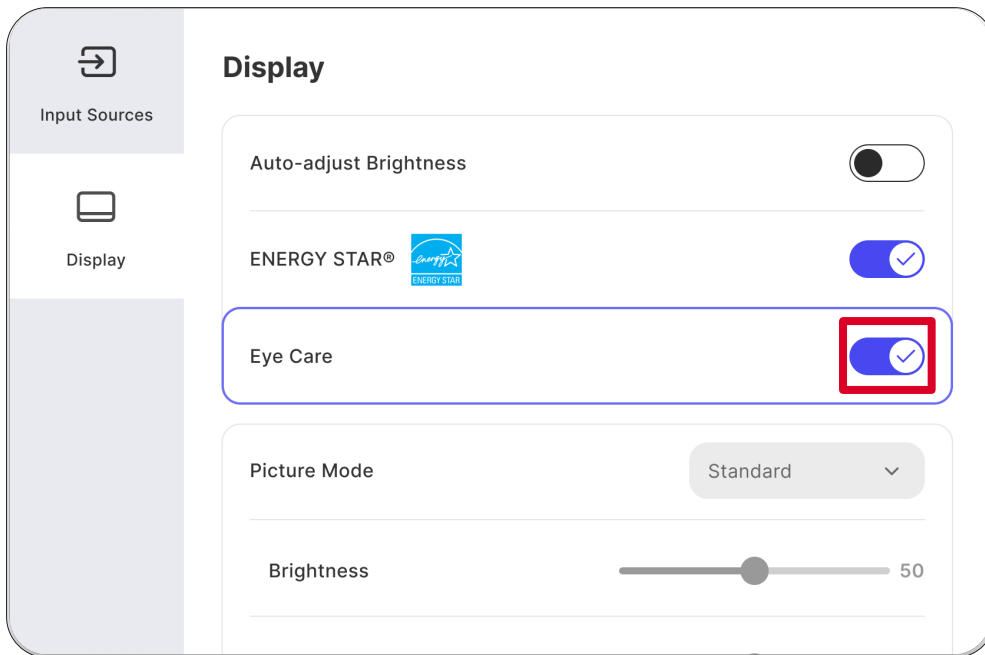

### Calculating Breaks

When viewing screens for extended periods, it is recommended to take periodic breaks from viewing. Short breaks of at least 10 minutes are recommended after one hour of continuous viewing.

Taking shorter, more frequent breaks are generally more beneficial than longer, less frequent breaks.

### Focus Fatigue (20-20-20 Rule)

To reduce the risk of eye fatigue by constantly looking at the screen, look away from the screen at least every 20 minutes and gaze at a distant object (at least 20 feet away) for at least 20 seconds.

### Looking at Distant Objects

While taking breaks, users can further reduce eye strain and dryness by focusing on objects that are further away from them for 10-15 seconds, then gaze at something up close for 10-15 seconds. Repeat this up to 10 times. This exercise reduces the risk of your eyes' focusing ability to "lock up" after prolonged computer work.

# Display Settings

## Google Launcher

### Network & Internet

Check current connection status, set up and manage Wi-Fi, Ethernet, VPN, and wireless Hotspot.

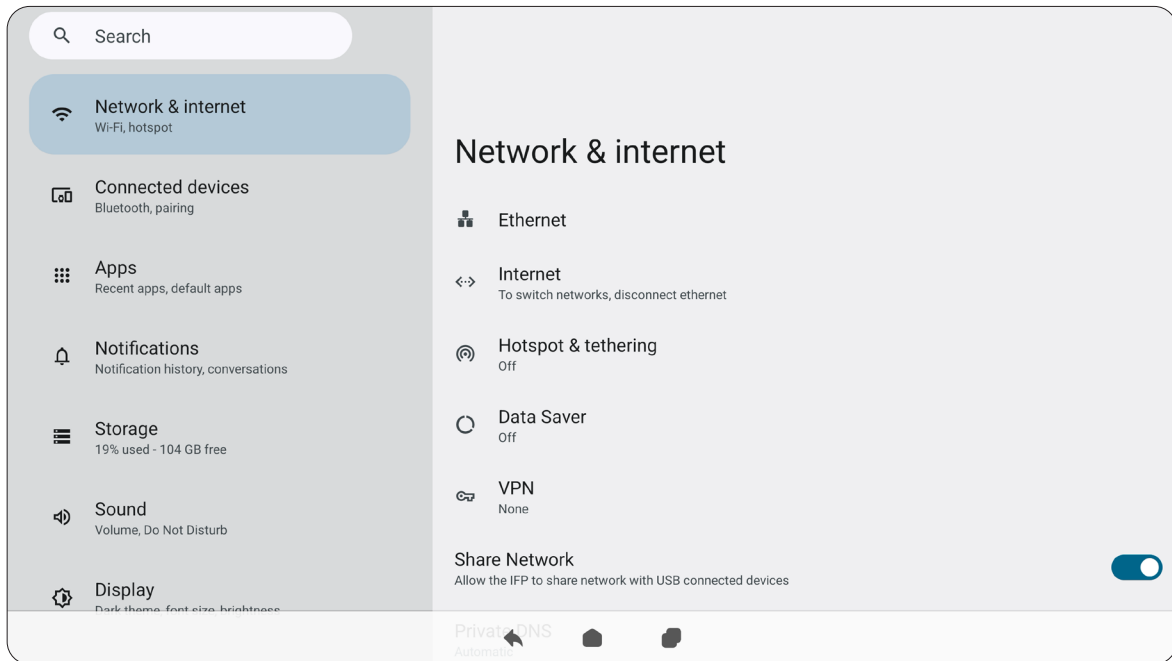

Item	Description
<b>Ethernet</b>	Set the Ethernet network settings.
<b>Internet</b>	Set up and manage Ethernet and Wi-Fi connection, as well as Network preferences.
<b>Airplane Mode</b>	When enabled, all wireless communication will be turned off.
<b>Hotspot &amp; Tethering</b>	Set and share your internet connection with other devices.
<b>Data Saver</b>	When enabled, most apps and services will get background data via an internet connection. Active apps will not be affected.
<b>VPN</b>	Set up and manage Virtual Private Networks.

Item	Description
<b>Share Network</b>	Enable to share the network with other USB connected devices.
<b>Private DNS</b>	Maintain an Automatic Private DNS or set one up manually for security and privacy.

**Note:**

- Wi-Fi, Hotspot, and Bluetooth settings will appear when an optional Wi-Fi card (e.g., VB-WIFI-004) has been installed in the Wi-Fi Slot.
- Ethernet will take priority when both Ethernet and Wi-Fi are enabled.
- The device can connect to the Internet when Hotspot is enabled.

## Connected Devices

Set up and manage Bluetooth connections, saved devices, and connection preferences for Bluetooth, Casting, and Print Services.

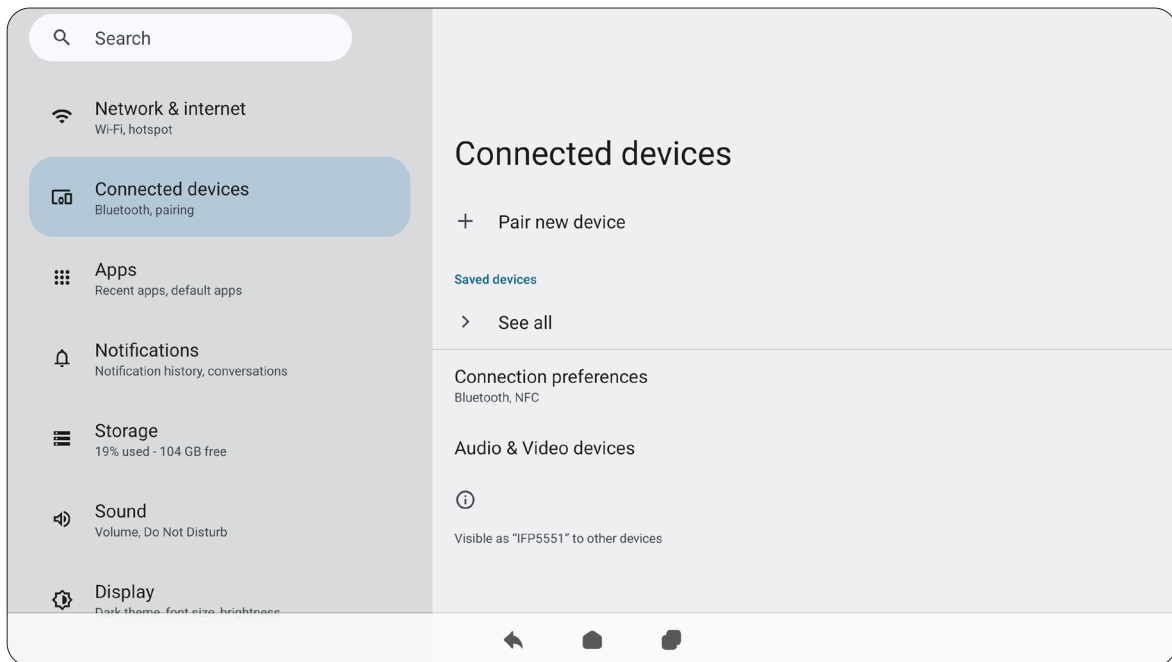

Item	Description
<b>Pair New Device</b>	Enable Bluetooth to search for and connect to a Bluetooth device.
<b>Saved Devices</b>	View all previously connected Bluetooth devices. <b>Note:</b> Bluetooth will turn on.
<b>Connection Preferences</b>	View Bluetooth, Cast, and Print Service preferences and share files with nearby devices.
<b>Audio &amp; Video Devices</b>	View all USB connected devices.

# Apps

View any running or installed applications. Tap on them for more detailed information and options.

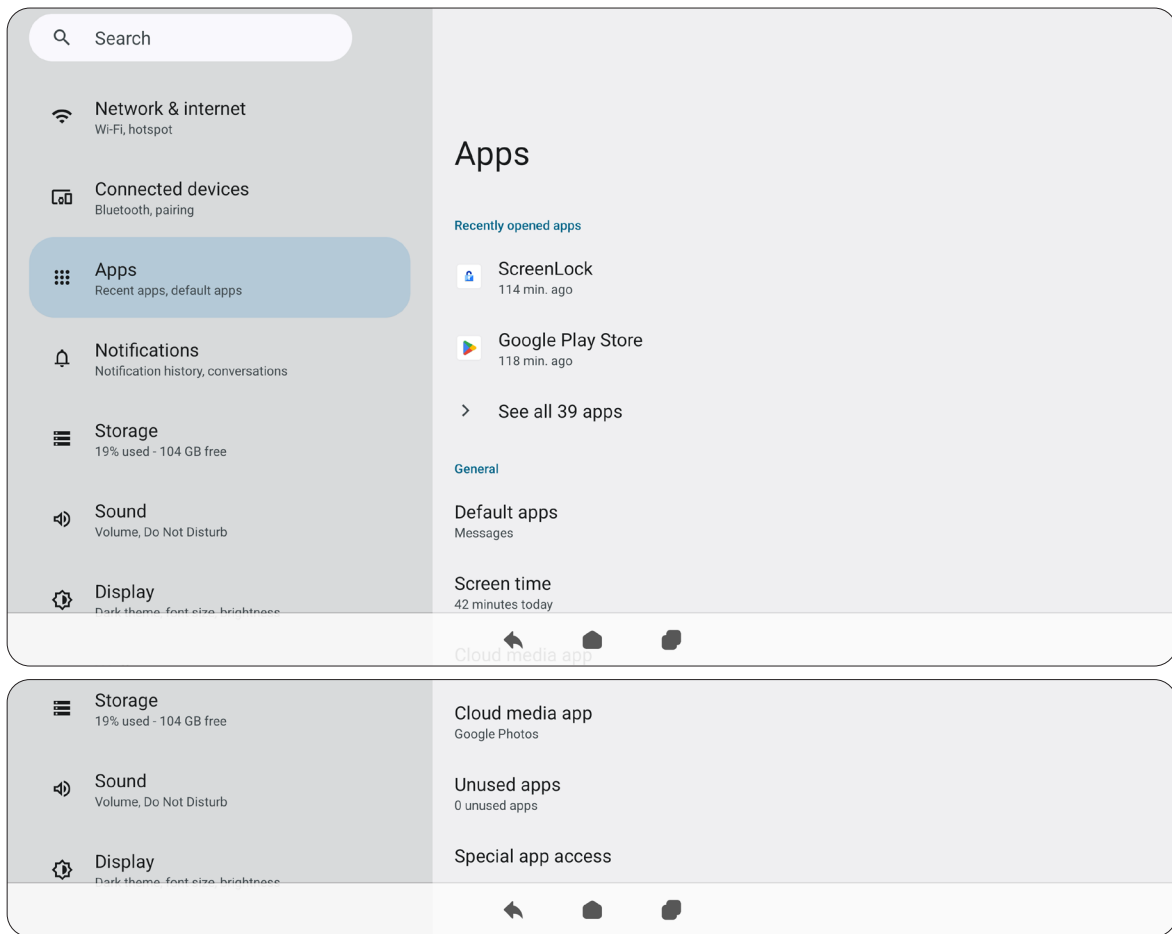

Item	Description
<b>Recently Opened Apps</b>	Any recently used applications will be listed here.
<b>Default Apps</b>	Set default applications for certain uses (e.g., default browser application).
<b>Screen Time</b>	Displays the total amount of time the ViewBoard has been in use by the day.
<b>Cloud Media App</b>	Set your cloud media items (e.g., photos, videos, etc.) locally on the ViewBoard.
<b>Unused Apps</b>	Applications that have not been used for a certain period of time will be listed here.
<b>Special App Access</b>	Set several access permissions for applications.

# Notifications

Manage notification and conversation settings and preferences.

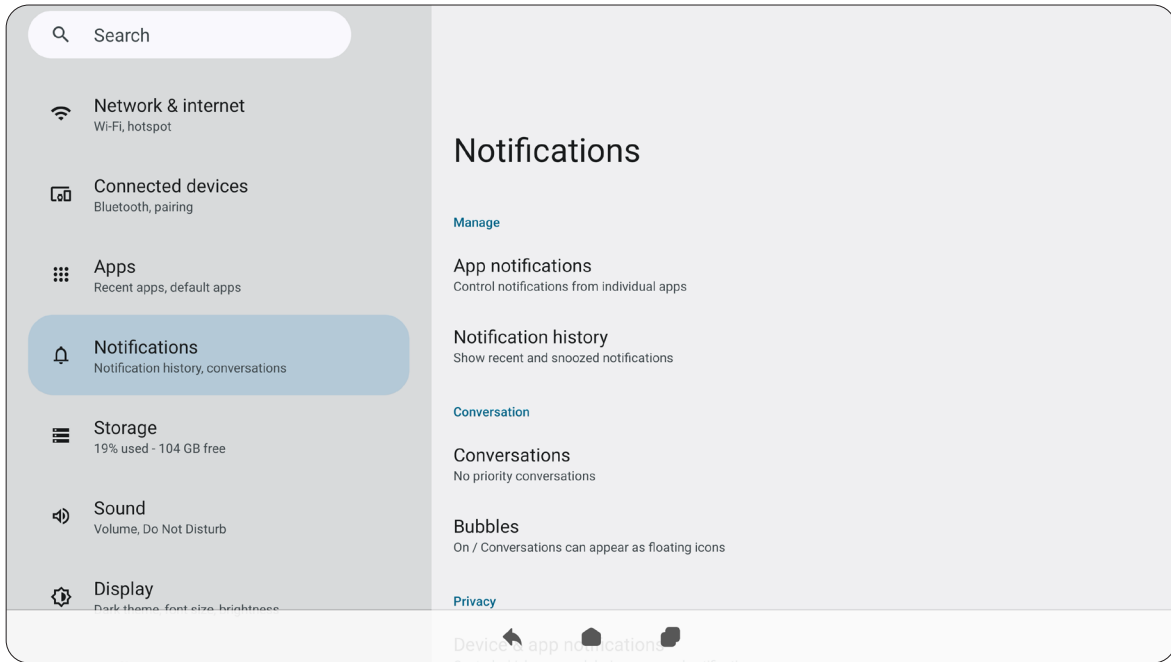

Item	Description
<b>App Notifications</b>	Set up notification settings for individual applications.
<b>Notification History</b>	View recent notifications.
<b>Conversations</b>	Set previously received notifications or messages as priority.
<b>Bubbles</b>	When enabled, conversations can appear as a floating icon on screen.
<b>Device &amp; App Notifications</b>	Control which applications and devices can read notifications.
<b>Notifications on Lock Screen</b>	Choose to show all, some, or no conversations or notifications on the lock screen.
<b>Do Not Disturb</b>	Set notification preferences for when “Do Not Disturb” mode is turned on.
<b>Flash Notifications</b>	Set the screen or camera to light up every time a notification comes in.
<b>Wireless Emergency Alerts</b>	Choose to receive or not receive Emergency Alerts.

<b>Item</b>	<b>Description</b>
<b>Hide Silent Notifications in Status Bar</b>	When enabled, notifications that have been “silenced” will no longer appear in the status bar area.
<b>Allow Notification Snoozing</b>	When enabled, notifications can be “snoozed” for a short period of time for applications.
<b>Notification Dot on App Icon</b>	When enabled, a small dot will appear on the application icon when there is a new notification available.
<b>Enhanced Notifications</b>	When enabled, receive suggestions for actions, replies, etc.

## Storage

Check the storage status of the ViewBoard.

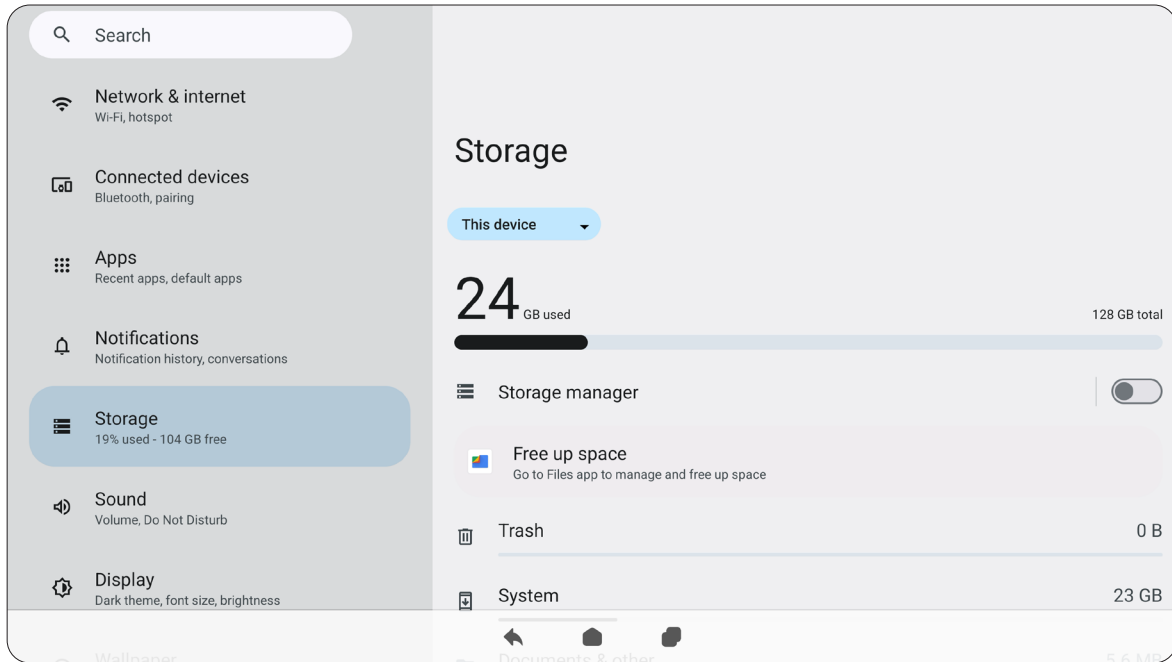

Item	Description
<b>Storage Manager</b>	When enabled, the storage manager will remove backed up photos and videos.
<b>Trash</b>	View and manage files that have been moved to the Trash.
<b>System</b>	View the total storage space of system files.
<b>Documents &amp; Other</b>	View and manage the Documents folder.
<b>Games</b>	View and manage the storage space used by gaming applications.
<b>Apps</b>	View and manage the storage space used by applications.
<b>Audio</b>	View and manage the Audio folder.
<b>Videos</b>	View and manage the Video folder.
<b>Images</b>	View and manage the Images folder.

## Sound

Adjust the volume level and set up various sound preferences.

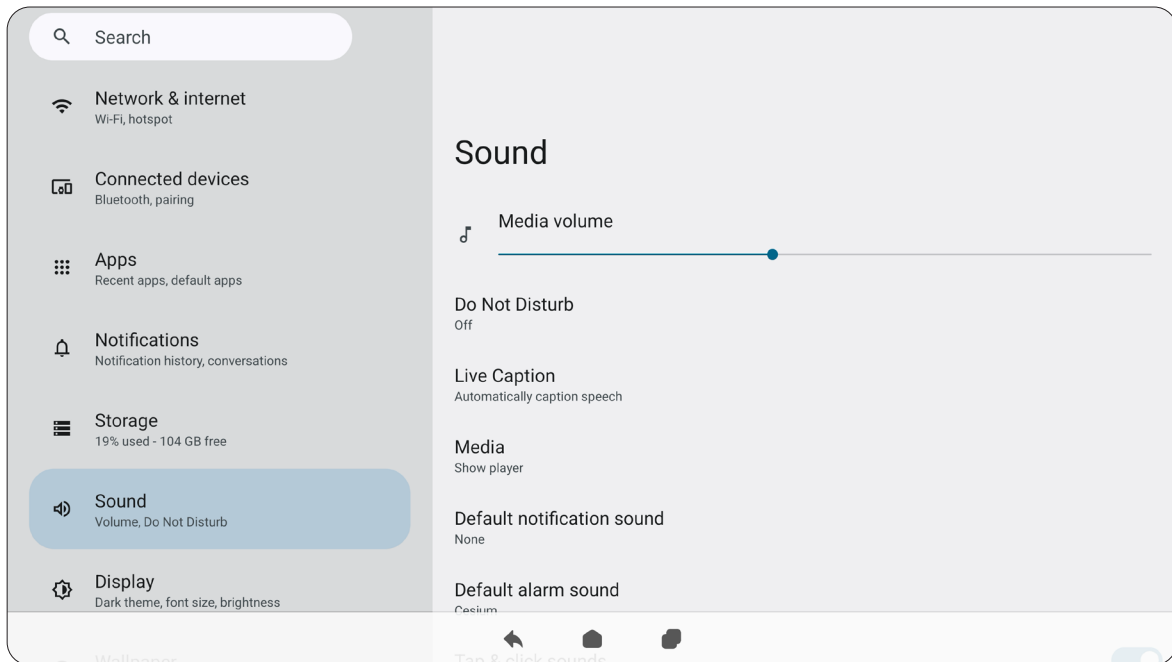

Item	Description
<b>Media Volume</b>	Adjust the volume level.
<b>Do Not Disturb</b>	Set sound preferences for when “Do Not Disturb” mode is turned on.
<b>Live Caption</b>	When enabled, automatically caption.
<b>Media</b>	Set the media player preferences.
<b>Default Notification Sound</b>	Choose the default sound effect for notifications.
<b>Default Alarm Sound</b>	Choose the default sound for alarms.
<b>Tap &amp; Touch Sounds</b>	When enabled, a sound effect will play every time a touch or tap input is received.

# Display

Adjust Brightness, Timeout, Theme, HDMI CEC, and other display related settings.

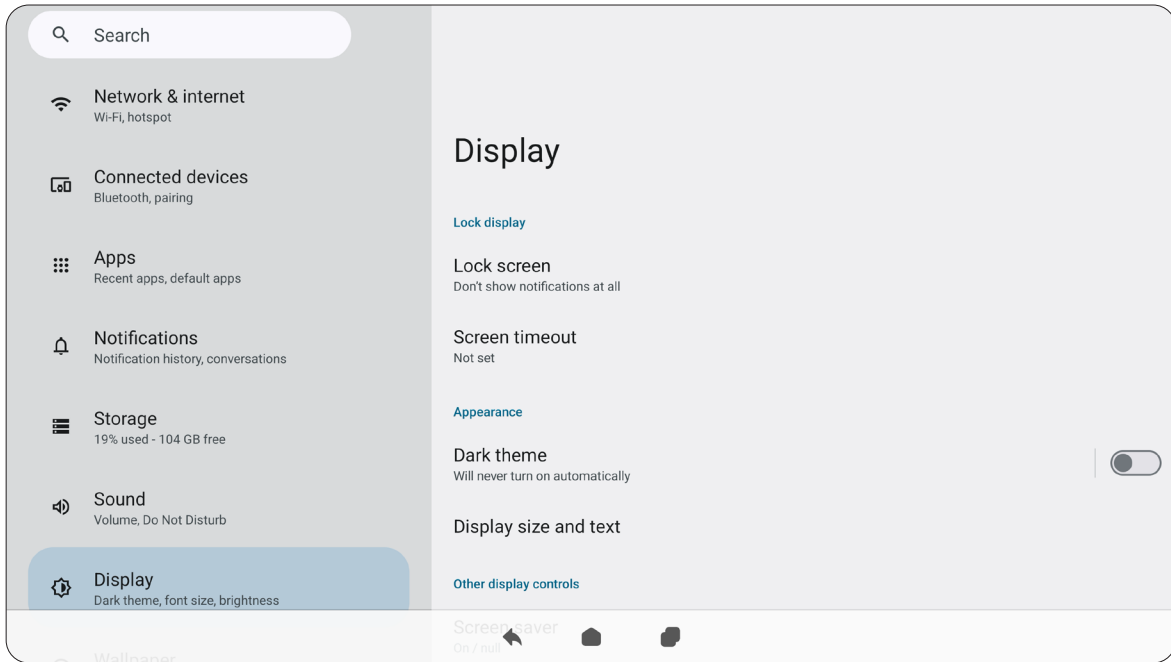

Item	Description
<b>Lock Screen</b>	Set lock screen preferences.
<b>Screen Timeout</b>	Set when the screen will lock after a period of inactivity.
<b>Dark Theme</b>	When enabled, the brighter default background color will be changed to a darker one.
<b>Display Size and Text</b>	Adjust the overall display size or only the text size.
<b>Screen Saver</b>	When enabled, a screen saver will play when the ViewBoard is not in use.

## Wallpaper & Style

Adjust and personalize the Wallpaper, Colors and theme of the ViewBoard.

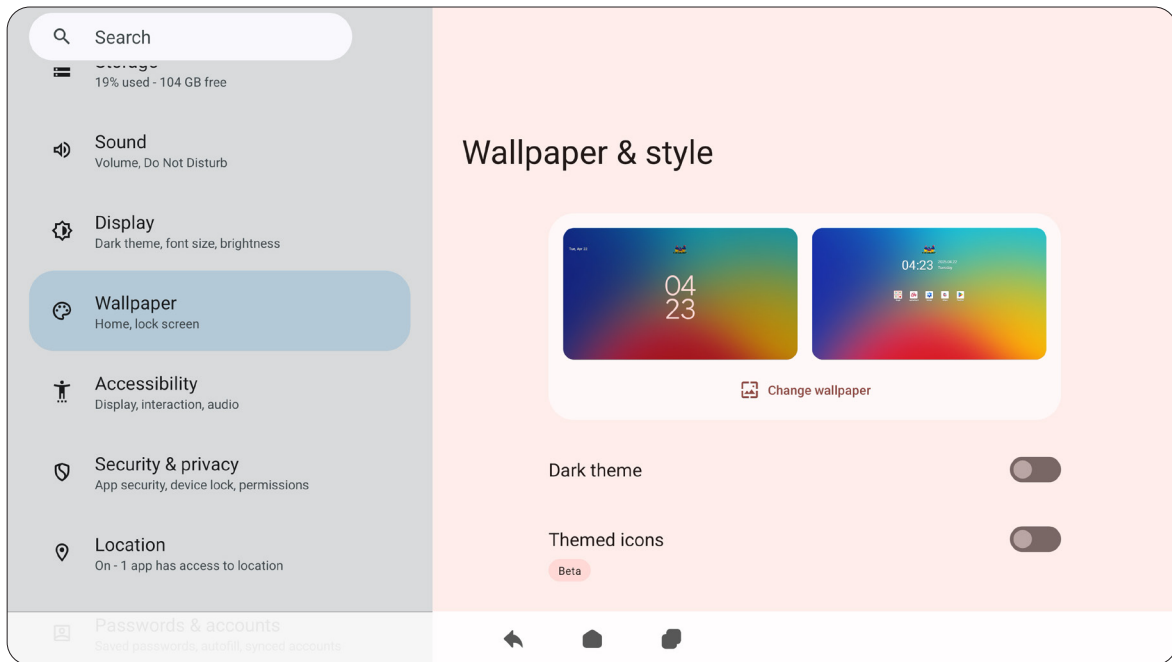

Item	Description
<b>Change Wallpaper</b>	Select a wallpaper for the background.
<b>Dark Theme</b>	When enabled, the brighter default background color will be changed to a darker one.
<b>Themed Icons</b>	Set a set of icons that match the style of the application icons on the Home Screen with your wallpaper.

## Accessibility

View and adjust various tools that can help people with visual, auditory, speech, or physical disabilities use the ViewBoard.

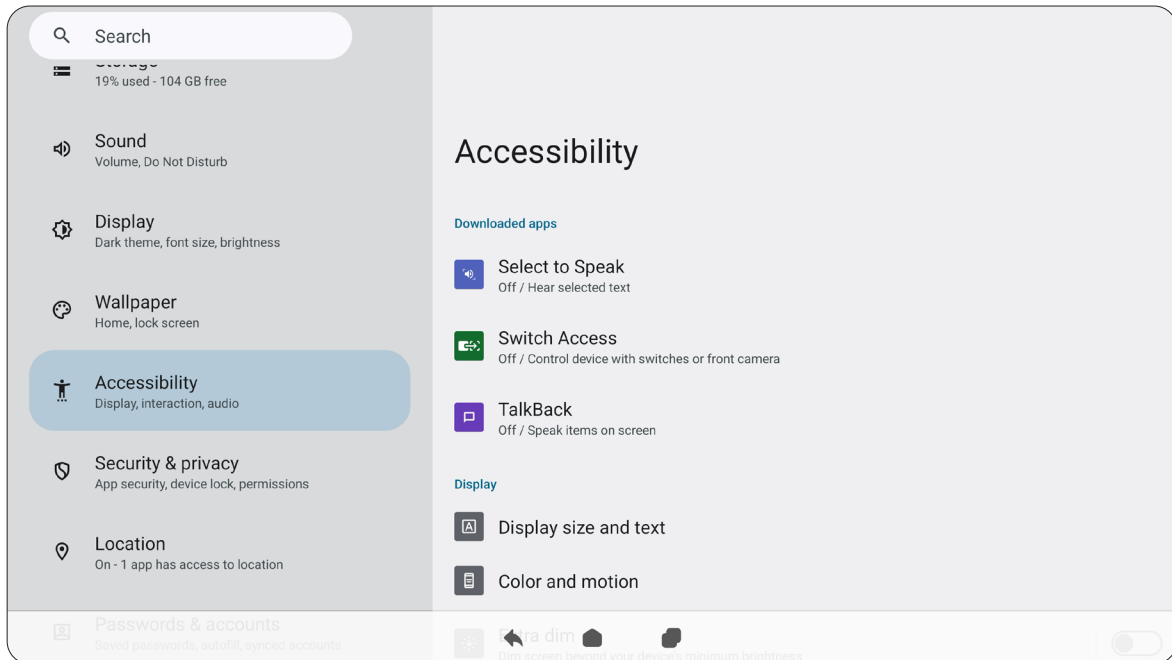

Item	Description
<b>Select to Speak</b>	When enabled, certain on-screen items will be read or described aloud when tapped (e.g., text or image).
<b>Switch Access</b>	Allows the use of one or more switches (e.g., keyboard, controller, etc.) to control the ViewBoard.
<b>TalkBack</b>	When enabled, device actions will be described by audio so it can be used without looking at the screen.
<b>Display Size and Text</b>	Adjust the overall display size or only the text size.
<b>Color and Motion</b>	Apply color correction and inversion and enlarge the mouse pointer.
<b>Extra Dim</b>	Dim the screen for a more comfortable viewing experience.
<b>Magnification</b>	Zoom in on the screen to enlarge the content.
<b>Accessibility Menu</b>	Add a shortcut for an enlarged on-screen menu to control the device.
<b>Timing Controls</b>	Adjust how long temporary messages that ask for an action are on screen, enable Auto click, and adjust the touch and hold delay time.
<b>System Controls</b>	Adjust the way to navigate the system.

<b>Item</b>	<b>Description</b>
<b>Live Caption</b>	Set the live caption preferences.
<b>Caption Preferences</b>	Enable captions and adjust the size and style.
<b>Audio Description</b>	When enabled, an audio description of what is happening on screen in supported movies and shows will be given.
<b>Flash Notifications</b>	Set the screen or camera to light up every time a notification comes in.
<b>Audio Adjustment</b>	Combine audio channels into a single mono channel.
<b>Accessibility Shortcuts</b>	Adjust the shortcut settings and availability on the lock screen.
<b>Text-to-Speech Output</b>	When set up, text can be read out loud.

# Security & Privacy

Review and adjust device security and privacy settings.

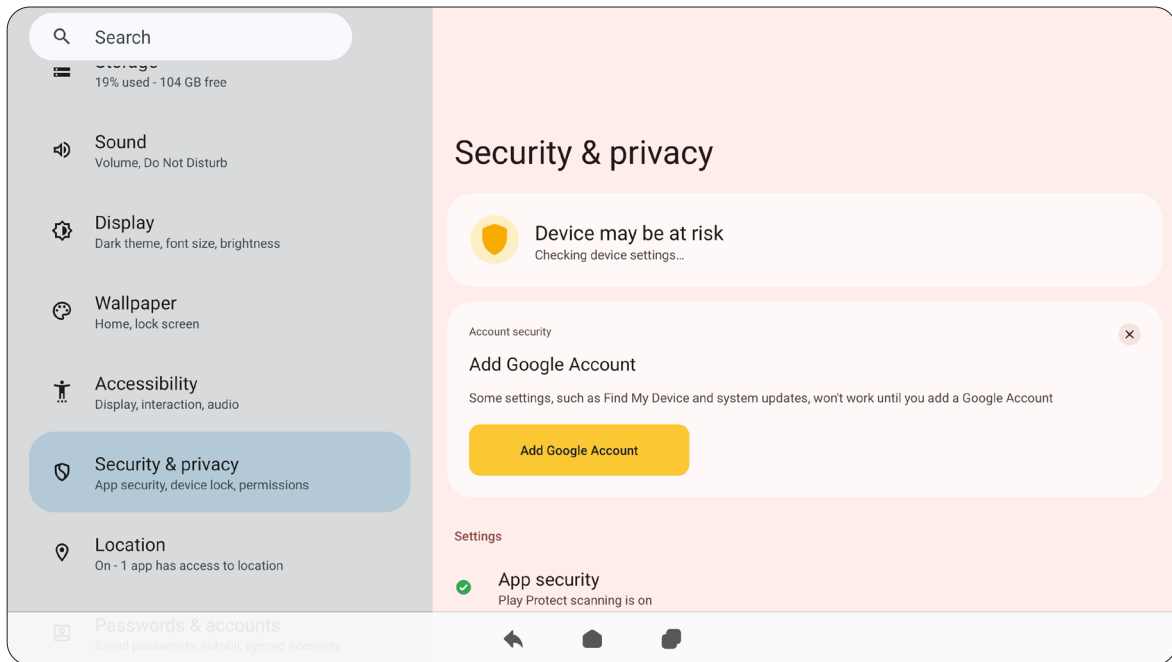

Item	Description
<b>Device May Be at Risk</b>	Scans regularly if the ViewBoard is safe from any harmful behaviors. Recommendations, and actions, will also be given to enhance the overall security and privacy.
<b>Add Google Account</b>	Add, remove, and manage your Google accounts linked to your ViewBoard.
<b>App Security</b>	Manage permissions for installed applications.
<b>Device Unlock</b>	Set the preferred options to lock/unlock the ViewBoard.
<b>Account Security</b>	Manage security permissions for all accounts on the ViewBoard.
<b>Device Finders</b>	Locate the ViewBoard remotely.
<b>System &amp; Updates</b>	Check for system and security updates.
<b>Privacy</b>	Manage application access to your data (e.g., location or camera permissions, etc.)
<b>More Security &amp; Privacy</b>	View and adjust additional security and privacy settings.
<b>More Security Settings</b>	View and adjust various security-related settings.

# Location

View and manage location settings.

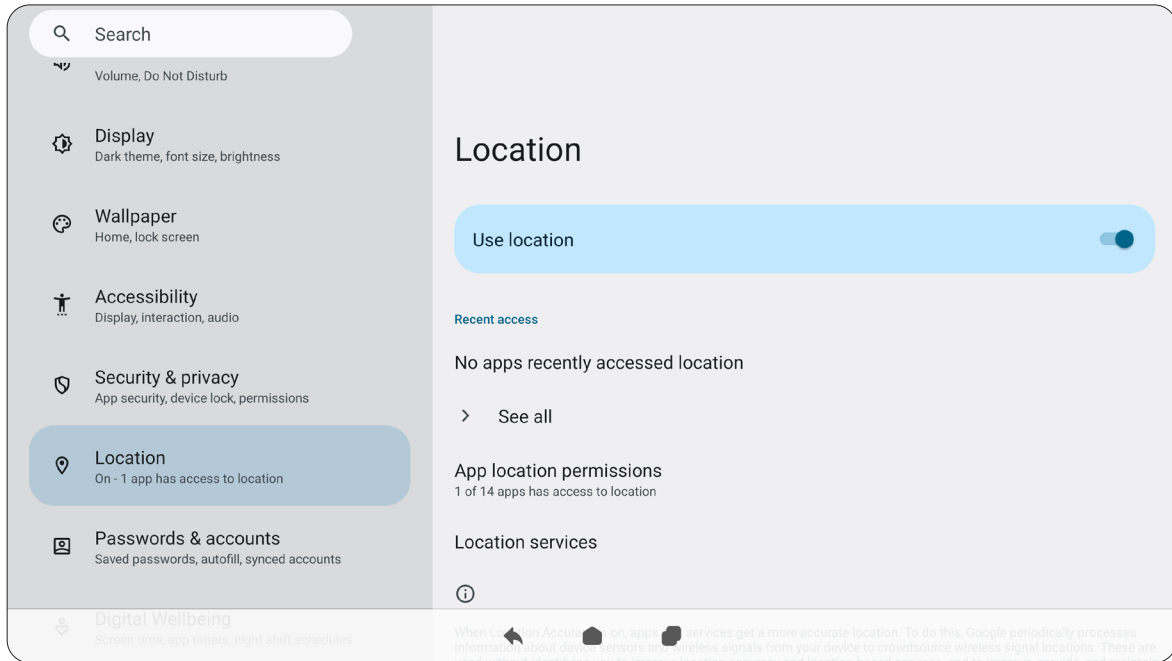

Item	Description
<b>Use Location</b>	When enabled, the location of the device will be accessible to applications.
<b>Recent Access</b>	Review which applications recently accessed the device's location.
<b>App Location Permissions</b>	Review which applications have permission to access the device's location.
<b>Location Services</b>	Turn on or off various alerts, services, and scanning related to location and location accuracy.

# Passwords & Accounts

Review saved passwords, select autofill services, and add accounts.

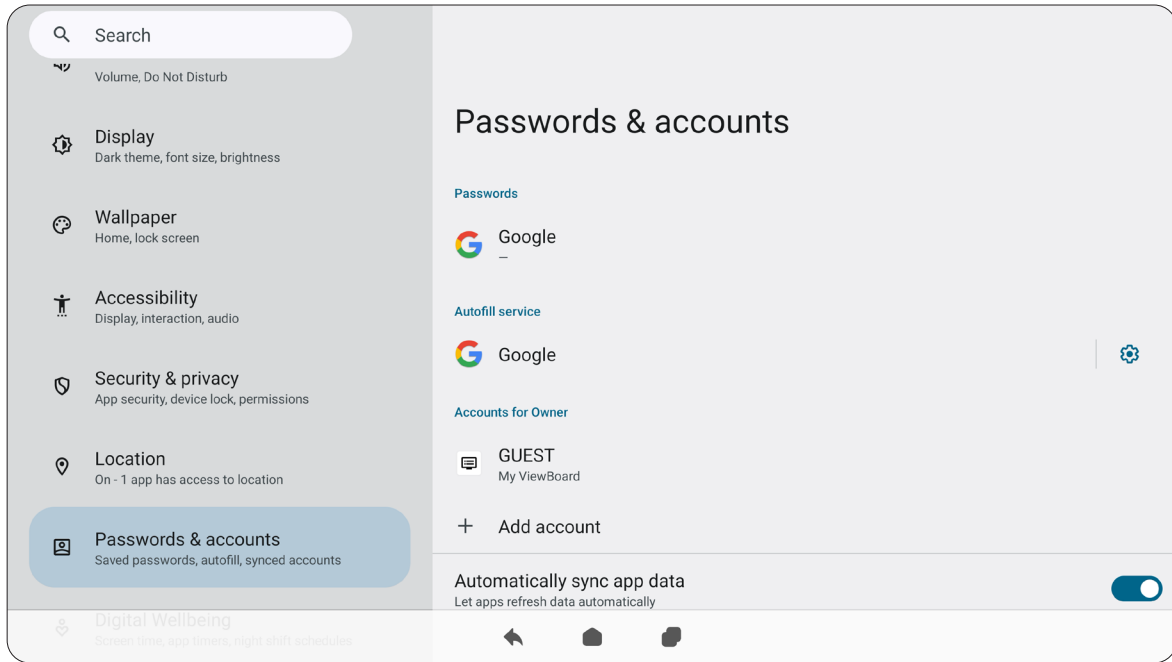

Item	Description
<b>Passwords</b>	Review saved passwords.
<b>Autofill Service</b>	Select which autofill service to use, if any.
<b>Accounts for Owner</b>	Add or remove accounts.
<b>Automatically Sync App Data</b>	When enabled, applications can refresh data automatically.

# Digital Wellbeing

Review the ViewBoard’s usage time, and set up various tools to promote a better balance with the device.

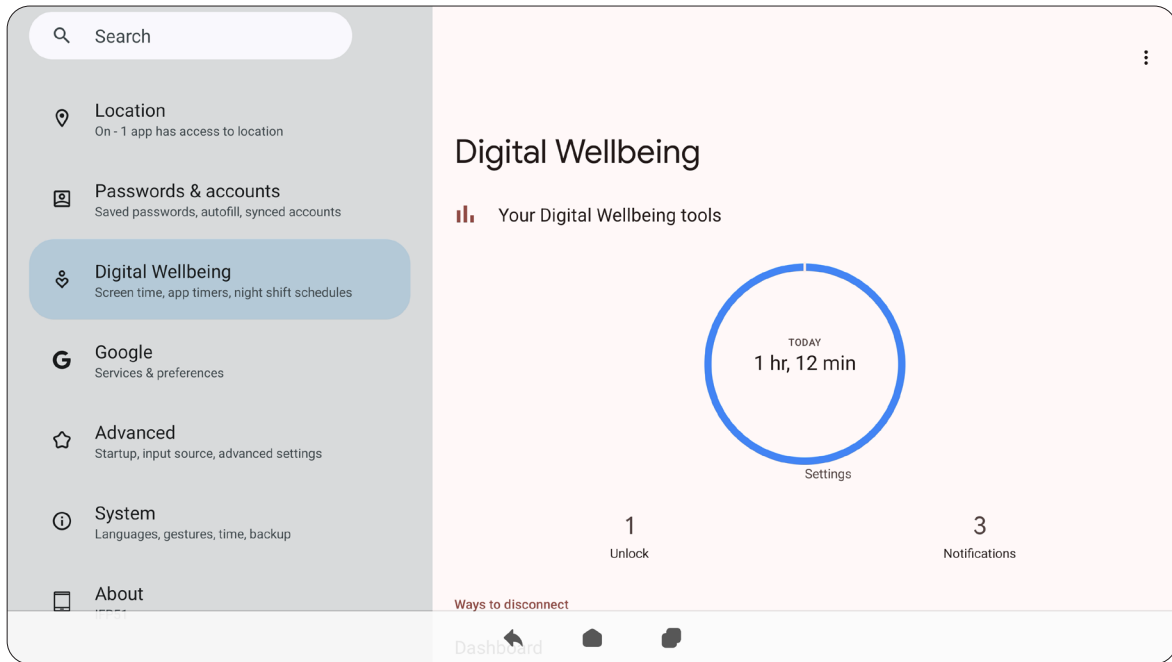

Item	Description
<b>Your Digital Wellbeing Tools</b>	A brief overview of device usage, unlocks, and notifications.
<b>Dashboard</b>	Review screen time, number of notifications, and number of device unlocks.
<b>Night Shift</b>	Reduce the amount of blue light emitted by the ViewBoard’s screen.
<b>Manage Notifications</b>	Review which applications can send notifications.
<b>Do Not Disturb</b>	Set notification preferences for when “Do Not Disturb” mode is turned on.
<b>Heads Up</b>	Set notification preferences when you’re moving with the ViewBoard.
<b>Show Icon in the App List</b>	Hide or display the Digital Wellbeing icon from your app list.

# Google

Review all of Google's services and set up preferences.

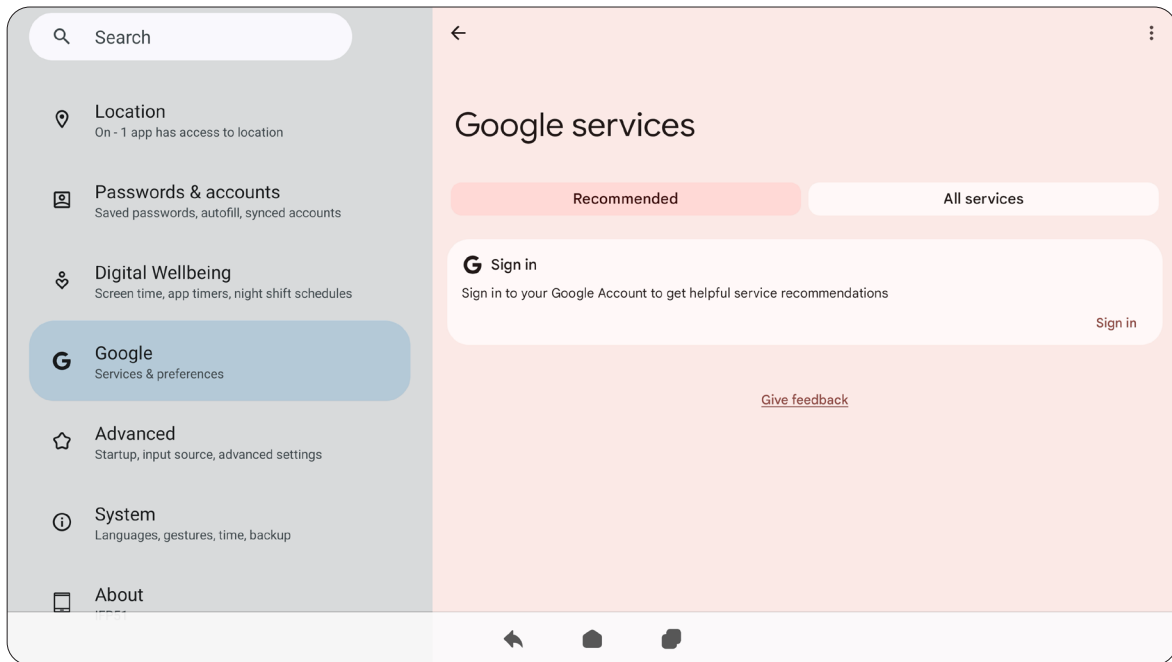

## Advanced

View and adjust various system settings.

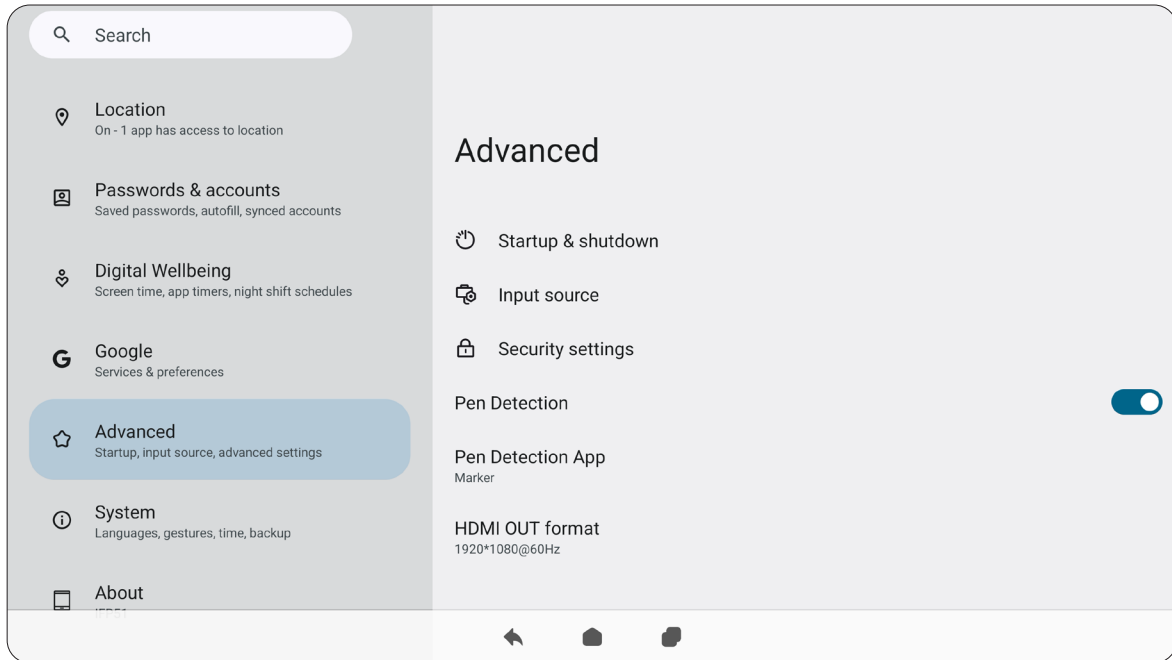

Item	Description
<b>Startup &amp; Shutdown</b>	Set the startup and shutdown settings.
<b>Input Source</b>	Adjust the input source names, HDMI CEC, and other input source settings.
<b>Security Settings</b>	Set a password for the ViewBoard or the advanced settings, or manage the permissions to install applications from unknown sources.
<b>Pen Detection</b>	Enable the Pen detection function.
<b>Pen Detection App</b>	Set the preferred app when the Touch Pen is detected.
<b>HDMI Out Format</b>	Se the preferred HDMI Out Resolution settings.

## System

View and adjust various system settings.

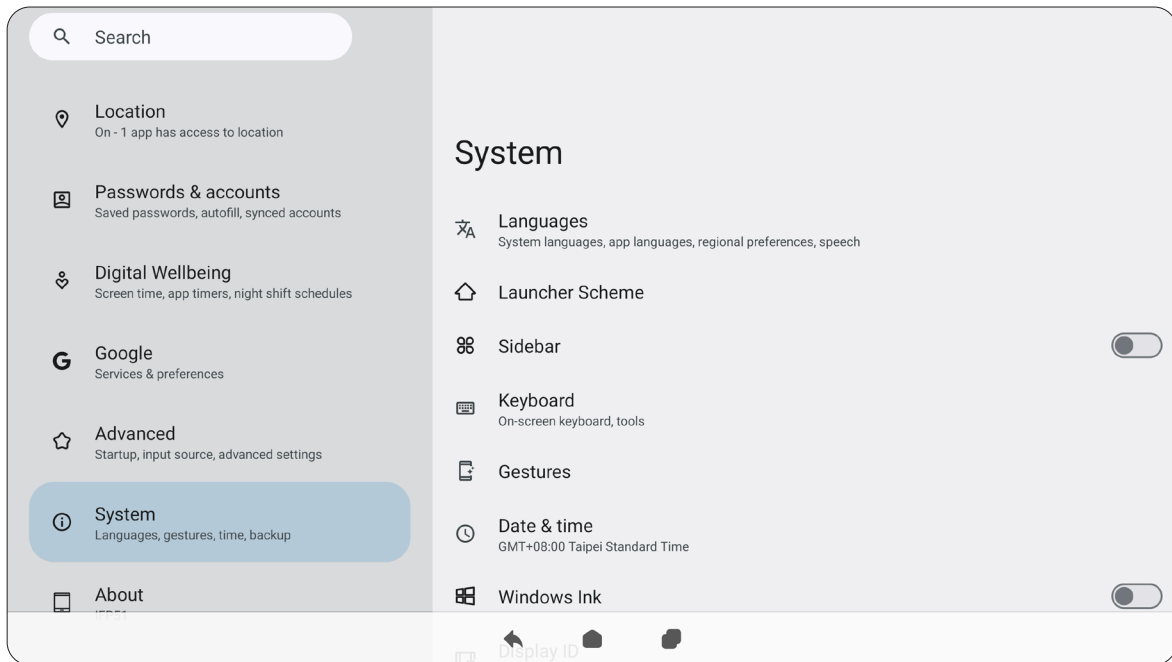

Item	Description
<b>Languages</b>	Choose the preferred language and input method.
<b>Launcher Scheme</b>	Choose between Scheme A and Scheme B to set the Home Screen layout.
<b>Sidebar</b>	Adjust the side toolbar settings.
<b>Keyboard</b>	Enable/disable the visual keyboard and/or change the default input method.
<b>Gesture</b>	Set the preferred touch gestures when using the ViewBoard.
<b>Date &amp; Time</b>	Set the date and time.
<b>Windows Ink</b>	Enable and set up Windows Ink support.
<b>Display ID</b>	Assign a number to remote control the display by RS-232/LAN.
<b>Backup</b>	With a Google account, back up the device's data.
<b>ViewSonic System Update</b>	Check for system updates.
<b>Multiple Users</b>	Review who is signed in and the available user logins.
<b>Reset Options</b>	Reset the ViewBoard to factory default settings.

## About Device

Review device information.

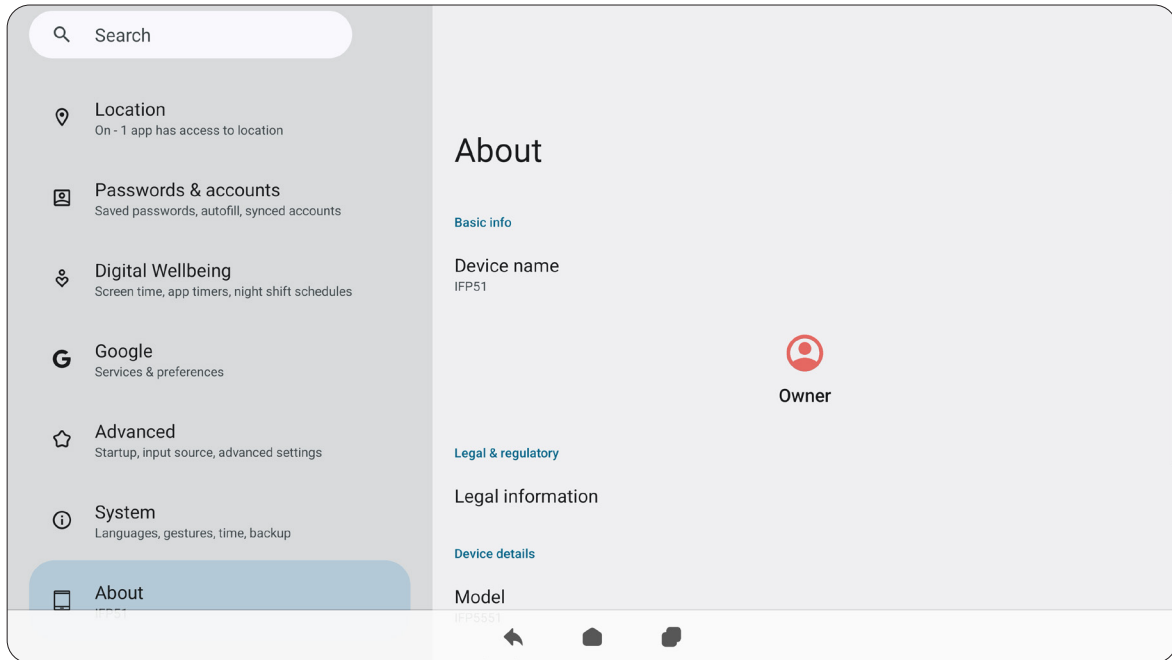

Item	Description
<b>Device Name</b>	View the name of the device.
<b>Legal Information</b>	View the relevant legal information.
<b>Model</b>	View the model of the ViewBoard.
<b>Android Version</b>	View the installed version of Android.
<b>IP Address</b>	View the IP Address.
<b>Ethernet Address</b>	View the Ethernet Address.
<b>Wi-Fi MAC Address</b>	View the Wi-Fi MAC Address.
<b>Device Wi-Fi MAC Address</b>	View the Device Wi-Fi MAC Address.
<b>Bluetooth Address</b>	View the Bluetooth Address.
<b>Up Time</b>	View how long the device has been in operation.
<b>Build Number</b>	View the build number.

## Tips & Support

View new features, tips, and get support for the myViewBoard Whiteboard, myViewBoard Display, and myViewBoard Manager applications.

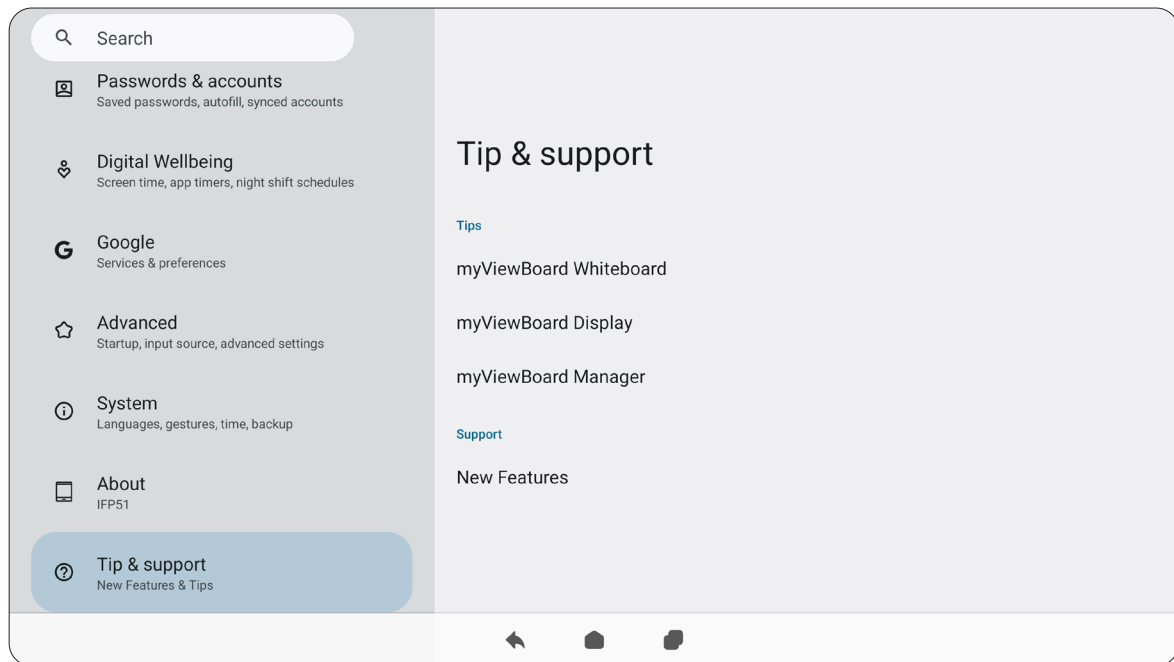

## Android Settings Menu Tree

Menu	Sub-menu	Menu Option			
<b>Network &amp; Internet</b>	Ethernet	DHCP			
		Static IP			
		IP Address			
		Default gateway			
		Netmask			
		DNS			
		Proxy			
		Mac address			
	Internet	Wi-Fi	Wi-Fi list		
			Add network		
		Network Preferences	Turn on Wi-Fi automatically		
			Notify for public networks		
			Share Wi-Fi only via a QR code		
			Install certificates		Recent
		Wi-Fi direct			
		Saved Networks	Other networks		
Non-carrier data usage					

Menu	Sub-menu	Menu Option			
Network & Internet	Hotspot & tethering	Wi-Fi hotspot	Use Wi-Fi hotspot		
			Hotspot name		
			Security		WPA2-Personal
			Turn off hotspot automatically		
			Extend compatibility		
		USB tethering			
		Bluetooth tethering			
	Data Saver	Unrestricted data			
	VPN	VPN+			
		VPN list			
	Shared network				
	Private DNS	Off			
		Automatically			
		Private DNS provider hostname			
		Enter hostname of DNS provider			

Menu	Sub-menu	Menu Option			
<b>Connected Devices</b>	USB	Connected device			
		This device			
		File transfer			
		USB tethering			
		PTP			
		No data transfer			
		Convert video to AVC			
		Charge connected device			
	Pair new device	Device name			
		Available devices			
	See all	Saved devices			
	Connection preferences	Bluetooth	Use NFC Bluetooth		
			Device name		
			Pair new device		
		NFC	Use NFC		Default payment app
			Contactless payments		
		Cast	Cast list		
		Printing	Default print Service		
			Add service		
		Quick share	Account		
			Device name		
			Who can share with you		

Menu	Sub-menu	Menu Option				
<b>Connected Devices</b>	Audio & video devices	Camera				
		Mic	Auto			
			Off			
			USB-audio touch device			
		Mic	Auto			
			Speaker			
			HDMI out			
		Speaker				
		<b>Apps</b>	Recently opened apps	App list	App info	
					Notifications	
Permissions	Location					
	Phone					
	Camera					
	Pause app activity is unused					
Storage & cache	Clear storage/cache					
	App size					
	User data					
	Cache					
	Total					
Mobile data & Wi-Fi	Total					
	Foreground					
	Background					
Screen time	App timer					
	Manage notifications					
	App used in the background					

Menu	Sub-menu	Menu Option		
Apps	Recently opened apps	App list	App battery usage	Unrestricted
				Optimized
				Restricted
			Open by default	Open supported links
			Pause app activity if unused	
			Display over other apps	
			Modify system settings	Allow modifying system settings
			Version	
	Default apps	Browser app	Default browser app	
		Digital assistant app	Use text from screen	
			Use screenshot	
			Flash screen	
		Home app	Default home app	
		SMS app	Default SMS app	
		Opening links	Instant apps	
			Instant apps preferences	
	Screen time	Activity details		
	Cloud media app			
	Unused apps			

Menu	Sub-menu	Menu Option	
<b>Apps</b>	Special app access	All files access	
		Device admin apps	
		Display over other apps	
		Do not disturb access	
		Media management apps	
		Modify system settings	
		Device & app notification	
		Picture-In-Picture	
		Premium SMS access	
		Unrestricted data	
		Install unknown apps	
		Alarms & reminders	
		Usage access	
		VR helper services	
		Wi-Fi control	
		Turn screen on	
Full screen notification			

Menu	Sub-menu	Menu Option	
Notifications	App notifications	App list	Screen lock
			All Google Play store notification
			All "Alerts" notifications
			Account
			App auto open
			Open app reminders
			Payments, Deals, and Recommendations
			Updates available
			Updates completed
			All "Essentials" notifications
			Maintenance
			Play Protect
			required
	Security and errors		
	Setup		
	All notification dot		
	Notification history	Use notification history	
Conversations			
Bubbles	Allow apps to show bubbles		
Device & app notifications	Allowed		
	Not allowed		

Menu	Sub-menu	Menu Option				
Notifications	Notifications on lock screen	Show conversations, default, and silent				
		Hide silent conversations and notification				
		Don't show any notifications				
	Sensitive notifications					
	Do not disturb	Turn on now				
		People			Messages	Starred contact
						Contacts
						Priority conversations
						Anyone
						None
		People	Calls	Starred contact		
				Contacts		
				Anyone		
				None		
				Allow repeat callers		
		Apps	Apps			
			Add apps			
Alarms & other interruptions		Alarms				
	Media sounds					
	Touch sounds					
	Reminders					
	Calendar events					

Menu	Sub-menu	Menu Option		
Notifications	Do not disturb	Schedules	Sleeping	User schedule
				Days
				Start time
				End time
				Alarm can override end time
				Do Not Disturb behavior
			Event	User schedule
				During events for
				Where reply is
				Do not disturb behavior
		Add more		
		Duration for quick settings		Until you turn off
				For 1 hour
				Ask every time
		Display options for hidden notification		No sound from notification
				No visuals or sound from notification
		Custom		Don't turn on screen
				Don't wake for notifications
				Hide notification dots on app icons
				Hide status bar icons at top of screen
			Don't pop notifications on screen	
Hide from pull-down shade				

Menu	Sub-menu	Menu Option			
<b>Notifications</b>	Flash notifications	Screen flash			
		Preview			
	Wireless Emergency Alerts				
	Hide Silent Notifications in Status Bar				
	Allow Notification Snoozing				
	Notification Dot on App Icon				
Enhanced Notifications					
<b>Storage</b>	Storage manager	User storage manager			
		Remove photos & videos			Over 30 days old
					Over 60 days old
					Over 90 days old
	Trash				
	System				
	Apps				
	Documents & other				
	Games				
	Apps				
	Audio				
	Videos				
Images					

Menu	Sub-menu	Menu Option				
<b>Sound</b>	Media volume					
	Do not disturb	People	Messages	Starred contacts		
				Contacts		
				Priority conversations		
				Anyone		
		None				
		Calls	Starred contacts			
			Contacts			
			Anyone			
	None					
	Apps	Apps				
		Add apps				
	Alarms & other interruptions	Alarms				
		Media sounds				
		Touch sounds				
		Reminders				
		Calendar events				

Menu	Sub-menu	Menu Option			
Sound	Do not disturb	Schedules	Sleeping	User schedule	
				Days	
				Start time	
				End time	
				Alarm can override end time	
				Do Not Disturb behavior	
			Event	User schedule	
				During events for	
				Where reply is	
				Do not disturb behavior	
		Add more			
		Duration for quick settings		Until you turn off	
				For 1 hour	
				Ask every time	
				No sound from notification	
				No visuals or sound from notification	
		Display options for hidden notification		Custom	Don't turn on screen
					Don't wake for notifications
					Hide notification dots on app icons
					Hide status bar icons at top of screen
			Don't pop notifications on screen		
Hide from pull-down shade					

Menu	Sub-menu	Menu Option			
<b>Sound</b>	Live caption	Use Live Caption			
		Language	(English only)		
		Hide profanity			
		Show sound labels			
		Live Caption in volume control			
		Help			
	Media	Pin media player			
		Show media on lock screen			
		Show media recommendations			
	Default notification sound	None			
		Adara/Aldebaran/Selenium/...			
		Add notification			

Menu	Sub-menu	Menu Option	
Sound	Default alarm sound	None	
		Argon	
		Barium	
		Bee-Beep alarm	
		Beep-Beep-Beep alarm	
		Buzzer alarm	
		Carbon	
		Cesium	
		Helium	
		Krypton	
		Neon	
		Neptunium	
		Osmium	
		Oxygen	
		Piezo alarm	
		Platinum	
		Rooster alarm	
Scandium			
Add alarm			
Tap & click sounds			

Menu	Sub-menu	Menu Option	
<b>Display</b>	Lock screen	Privacy	Show all notification content
			Show sensitive content only when unlocked
			Don't show notifications at all
		Add users from lock screen	
		Add text on lock screen	
		Show device controls	
		Use device controls	
		Dynamic clock	
		Wake screen for notifications	
		Double-line clock	
	Screen timeout	15 seconds	
		30 seconds	
		1 minute	
		2 minutes	
		5 minutes	
		10 minutes	
		30 minutes	

Menu	Sub-menu	Menu Option	
Display	Dark theme	Use dark theme	
		Schedule	None
			Turns on at custom time
			Turns on from sunset to sunrise
			Turns on bedtime
	Display size and text	Font size	
		Display size	
		Bold text	
		High contrast text	
		Reset settings	
	Screen saver	Use Screen Saver	
		Screen saver	Never
			15 min
			30 min
			60 min
			90 min
		Choose a screen saver	Clock
			Colors
			Photos frame
			Photo table
Photo			

Menu	Sub-menu	Menu Option		
<b>Wallpaper &amp; Style</b>	Wallpaper	Home screen		
		Lock screen		
	Change wallpaper	My Photos	Select a photo	
		On-device wallpapers	Preview	
		Cityscapes		
		Life		
		Textures		
		Landscapes		
		Art		
		Earth		
		Solid colors		
		Geometric shapes		
		Seascape		
	Wallpapers			
	Dark theme			
	Themed icons			

Menu	Sub-menu	Menu Option				
<b>Accessibility</b>	Select to speak	Select to speak shortcut				
		Settings	Text to speech settings	Preferred engine		
				Language		
				Speech rate		
				Pitch		
		Change reading voice				
		Read in background				
		Read text on images				
		Help & feedback	Popular help resources			
		Developer settings	Enable taking snapshot			
			Allow snapshot to take detail information			
	Switch access	Use Switch Access	Choose a switch type			
		Switch Access shortcut				

Menu	Sub-menu	Menu Option		
<b>Accessibility</b>	Switch access	Settings	Help & feedback	Popular help resources
			Open setup guide	Choose a switch type
			Camera switch settings	Use camera switches
				Open mouth
				Smile
				Raise eyebrows
				Look left
				Look right
				Look up
				Enhanced visual feedback
				Enhanced audio feedback
				Keep screen on
			Assign switches for scanning	Ignore repeated camera switch triggers
				Pause camera Switch
				Auto-scan
				Reverse auto-scan
				Select
				Next
				Previous
				Touch & hold
Assign switches to shortcuts	Scroll forward			
New shortcuts				

Menu	Sub-menu	Menu Option		
<b>Accessibility</b>	Switch access	Settings	Enable menu customization	
			Revert to Default Menu	Restore default menu
			Auto-scan	Auto-scan time
				Delay on first item
				Number of scans
			Scanning method	Linear scanning
				Row-column scanning
				Group selection
			Point scan	Line speed
				Delay on first item
				Number of scans
				Vertical scans
				Horizontal scans
			Automatically start scanning	
			Auto-select	
Scanning highlight style	Highlight color			
	Highlight line style			

Menu	Sub-menu	Menu Option		
<b>Accessibility</b>	Switch access	Settings	Speech, sound & vibration	Spoken feedback
				Speak descriptive text
				Verbosity
				TTS settings
				Finish speech before moving
				Maximum spoken time per item
				Vibration feedback
				Sound feedback
				Sound volume
				Audio ducking
			Ignore repeated presses	
			Release to perform action	
			Privacy policy	
			Developer settings	Version
				Display speech output
				Delete all shortcuts
Log output level				

Menu	Sub-menu	Menu Option		
<b>Accessibility</b>	TalkBack	Use TalkBack		
		TalkBack shortcut		
			New features in TalkBack	
			Text-to-speech settings	Preferred engine
				Language
				Speech rate
				Pitch
				Play/Reset
		Settings		Choose a preset
				Speak usage hints
				Speak list and grid info
				Always speak number of list items
				Speak element type
				Speak window names
				Speak notifications when screen is off
				Use pitch changes
				Speak letters with examples
				Keyboard echo: On-screen keyboard
				Keyboard echo: Physical keyboard
				Capital letters
	Speak all progress updates			
	Speak element IDs			
	Speak punctuation and symbols			

Menu	Sub-menu	Menu Option		
<b>Accessibility</b>	TalkBack	Settings	Sound	Accessibility volume
				TalkBack speech rate
				Sound feedback
				Sound feedback volume
				Audio ducking
			Customize focus	Thick borders
				Color default
				Red
				Orange
				Yellow
				Green
				Blue
			Customize Gestures	Practice gestures
				Reset gesture setting
				Swipe up/Swipe down/Swipe left/...
			Customize menus	Customized TalkBack menu
				Customized reading controls
			Image & icon descriptions	Detailed image descriptions
				Automatic image descriptions
				Automatic icon descriptions
Automatic descriptions for text in image				

Menu	Sub-menu	Menu Option		
<b>Accessibility</b>	TalkBack	Settings	Braille keyboard	Set up braille keyboard
				Review all gestures
				Languages
				Preferred typing language
				Preferred braille grade
				Layout
				Include all pressed dots
				Reverse dots
			Braille display	Use braille display
				Look for new device
				Languages
				Preferred reading language
				Preferred typing language
				Preferred braille grade
				Braille display commands
				Braille elements
				Auto-connect
				Auto-scroll

Menu	Sub-menu	Menu Option		
<b>Accessibility</b>	TalkBack	Settings	Advanced settings	Speak passwords
				Custom labels
				Single-tap to activate
				Element description order
				Time format
				Reduce window announcement delay
				Typing preference
				Touch and hold delay when typing
				Keyboard shortcut
				Developer settings
				Privacy policy
				Terms of service
			Open Talkback at the Play Store	
			TalkBack tutorial	
			Help & feedback	
			Contact Google disability support	
			Display size and text	Font size
Display size				
Bold text				
High contrast text				
Reset settings				

Menu	Sub-menu	Menu Option		
<b>Accessibility</b>	Color and motion	Color correction	Use color correction	
			Red-green	
			Red-green	
			Blue-yellow	
			Grayscale	
			Color correction shortcut	
		Color inversion	Use color inversion	
			Color inversion shortcut	
		Dark theme	Use dark theme	
			Schedule	
	Turns on a custom time			
	Turns on from sunset ro sunrise			
			Turns on at bedtime	
	Large mouse pointer			
	Extra dim	Make scree extra dim		
Intensity				
Keep on after device restarts				
Extra dim shortcut				

Menu	Sub-menu	Menu Option	
<b>Accessibility</b>	Magnification	Magnification shortcut	
		Magnification type	Magnify full screen
			Magnify part of screen
		Magnify typing	
		Keep on while switching apps	
	Accessibility menu	Accessibility Menu shortcut	
		Settings	Large button
			Help & feedback
	Time controls	Touch & hold delay	Short
			Medium
			Long
		Time to take action	Default
			10 seconds
			30 seconds
			1 minute
			2 minutes
		Autoclick	Autoclick off
			Short
			Medium
			Long
Custom			

Menu	Sub-menu	Menu Option					
Accessibility	System controls	Navigation mode	Gesture navigation	Swipe to invoke assistant			
				Left edge			
				Right edge			
				Hold Home for Assistant			
			3-button navigation				
			Side toolbar navigation				
	Live caption		Use live caption				
			Languages				
			Hide profanity				
			Show sound labels				
			Live caption in volume control				
			Help				
	Caption preferences		Show captions				
			Caption size and style			Text size	Very small
							Small
							Medium
							Large
				Very large			
			Caption style	Set by app			
				White on black			
Black on white							
Yellow on black							
Yellow on blue							
Custom							
More options			Languages				

Menu	Sub-menu	Menu Option		
<b>Accessibility</b>	Audio description			
	Flash notifications	Screen flash		
		Preview		
	Audio adjustment	Mono audio		
	Accessibility shortcuts	Accessibility button	Location	Floating over other apps
				Navigation bar
			Size	Small
				Large
			Fade when not in use	
			Transparency when not in use	
			Shortcut from lock screen	
	Text-to-speech output	Preferred engine		
		Language		
		Speech rate		
		Pitch		
Play/Reset				

Menu	Sub-menu	Menu Option		
Security & Privacy	Device may be at risk			
	Add Google Account			
	Check for security updates			
	Check for system updates			
	App security	Google Play protect		
	Device unlock	Screen lock PIN	Enhanced PIN privacy	
			Lock after screen timeout	Immediately
				5 seconds
				15 seconds
				30 seconds
				1 minute
				2 minute
				5 minute
				10 minute
	30 minute			
Never				
Account security	Google security Checkup			
	Password checkup			
Device finders	Find my device	Use find my device		
	Unknow tracker alerts			

Menu	Sub-menu	Menu Option						
<b>Security &amp; Privacy</b>	System & updates	Check for security updates						
		Check for system updates						
		Security update						
		Google Play system update						
		Backup						
	Privacy	Permission manager						
		Privacy dashboard						
		Ads					Ad privacy	Ad topics
								App-suggested ads
								Ad measurement
			Reset advertising ID					
			Delete advertising ID					
			Enable debug logging for ads					
		Health connect						
		Data sharing updates for location						
		Camera access						
		Microphone access						
		Show clipboard access						
		Show passwords						

Menu	Sub-menu	Menu Option		
<b>Security &amp; Privacy</b>	Privacy	Location access	Use location	
			No apps recently accessed location	
			App location permissions	
			Location services	
		Activity controls		
	More security settings	Accessibility usage		
		Notifications on lock screen	Show all notification content	
			Show sensitive content only when unlocked	
			Don't show notifications at all	
		Show media on lock screen		
		App content		
		Android system Intelligence	Device learning	
			Keyboard	
			On-device recognition	
			Clear data	
		Last 24 hours		
		All time		

Menu	Sub-menu	Menu Option			
<b>Security &amp; Privacy</b>	More security settings	Encryption & credentials	Encrypt device		
			Trusted credentials		
			User credentials		
			Install a certificate	CA certificate	
				VPN & app user certificate	
				Wi-Fi certificate	
			Clear credentials		
			Certificate management app		
			Trust agents		Extend unlock
			App pinning		Use app pinning
Lock device when unpinning					
<b>Location</b>	Use location				
	Recent access				
	App location permissions		App list		
	Location services		Earthquake alerts		
			Emergency location Service		
			Google location History		
			Google location Sharing		
			Location accuracy		
			Trusted places		
			Wi-Fi scanning		
Bluetooth scanning					

Menu	Sub-menu	Menu Option					
<b>Passwords &amp; accounts</b>	Passwords						
	Autofill service						
	Accounts for owner						
	Add account						
	Automatically sync app data						
<b>Digital Wellbeing</b>	Your Digital Wellbeing tools	Unlocks					
		Notifications					
	View activity details						
	App limits						
	Night shift	Do not disturb for night shift mode					
	Focus						
	Screen time reminders						
	Manage notifications	App notifications					
	Do Not Disturb				People	Messages	Starred contacts
							Contacts
							Priority conversations
							Anyone
							None
Calls			Starred contacts				
			Contacts				
			Anyone				
			None				
Apps				Apps			
	Add apps						

Menu	Sub-menu	Menu Option		
<b>Digital Wellbeing</b>	Do not disturb	Alarms & other interruptions	Alarms	
			Media sound	
			Touch sounds	
			Reminders	
			Calendar events	
		Schedule	Sleeping	User schedule
				Days
				Start time
				End time
				Alarm can override end time
				Do not disturb behavior
			Event	User schedule
				During events for
				Where reply is
				Do not disturb behavior
		Duration for quick settings	Add more	
			Until you turn off	
			For 1 hour	
			Ask every time	

Menu	Sub-menu	Menu Option		
<b>Digital Wellbeing</b>	Do not disturb	Display options for hidden notifications	No sound from notifications	
			No visuals or sound from notifications	
			Custom	Don't turn on screen
				Don't wake for notifications
				Hide notification dots on app icons
				Hide status bar icons at top of screen
		Don't pop notifications on screen		
		Hide from pull-down shade		
	Heads up			
	Show icon in the app list			
Parental controls				

Menu	Sub-menu	Menu Option		
<b>Google</b>	Google services			
	Backup is off for photos & videos	Account storage		
		Backup by Google One		
		Backup details		
		Apps		
		Photo & videos		
		Device settings		
				Calendar
				Contacts
				Drive
				Gmail
				Google Calendar
				Google TV
				Tasks in Calendar
		Back up using meter Wi-Fi data		
	Find my device	Use find my devices		
		Find your offline devices		Off
				Without network
				With network in high-traffic areas only
				With network in all areas
		Find my device app		
		Find my device web		

Menu	Sub-menu	Menu Option				
Google	Autofill	Use autofill with Google				
		Google Account				
		Personal info				
		Google Password Manager				
		Google Pay				
		Preferences				
	Google Wallet					
	Cross-device services	Account				
		Device name				
		Who can share with you			Your devices	
					Contacts	
	Everyone					
	Family group	Creat a family group				
	What's new					
	Give feedback					
	Parental Controls					

Menu	Sub-menu	Menu Option	
<b>Advanced</b>	Startup & shutdown	Boot mode	Normal mode
			Secure mode
			Disable embedded OS
		Startup input	Last shutdown channel
			ViewBoard
			HDMI 1
			HDMI 2
			HDMI 3
			HDMI 4
			DP
			VGA
			TYPE C 1
			TYPE C 2
			Standby Mode
		Sleep	
		Energy Star mode	
		Add startup/ shutdown task	Startup task/ Shutdown task
			Schedule settings

Menu	Sub-menu	Menu Option	
<b>Advanced</b>	Input source	Label input Source	Allow input alias
			ViewBoard
			HDMI 1
			HDMI 2
			HDMI 3
			HDMI 4
			DP
			VGA
			Type-C 1
			Type-C 2
			Wake up by active HDMI input
		Auto search signal	
		Auto switch input ports	
		Energy saving	1 min
			3 mins
			5 mins
			10 mins
			15 mins
			30 mins
			45 mins
			60 mins
		Off	
		HDMI CEC	
		HDR	

Menu	Sub-menu	Menu Option			
<b>Advanced</b>	Security settings	Unknown source security			
		Enable password for ViewBoard settings			
		Reset Advanced Settings Password			
	Pen detection				
	Pen detection app	Marker			
		myViewBoard whiteboard			
	HDMI OUT format	3840 x 2160 @ 60 Hz			
		1920 x 1080 @ 60 Hz			
		720 x 480 @ 60 Hz			
		Auto			
<b>System</b>	System languages				
	App Languages				
	Regional preferences	Regional preferences			
		Temperature	Use default		
	Celsius (°C)				
	Fahrenheit (°F)				
	Regional preferences	First day of week	Use default		
			Sunday		
			Monday		
			Tuesday		
			Wednesday		
			Thursday		
			Friday		
Saturday					
Voice input					

Menu	Sub-menu	Menu Option			
System	On-device recognition	Add language			
		Auto update languages			
		Advanced			
	Text-to-speech output	Preferred engine			
		Languages			
		Speech rate			
		Pitch			
		Play/Reset			
	Launcher Scheme	Scheme A			
		Scheme B			
	Sidebar	On/Off			
	Keyboard	Gboard			
		Google Voice Typing			
		Remoting			
		Use on-screen keyboard			
		Keyboard shortcuts	Caps lock		
			Ctrl		
			Action key		
			Alt		
			Reset all		
		Spell checker	Use spell checker		
	Languages				
	Default spell checker				
	Personal dictionary				
	Pointer speed				

Menu	Sub-menu	Menu Option	
<b>System</b>	Gestures	Navigation mode	Gesture navigation
			3-button navigation
			Side toolbar navigation
		Press & hold power button	Power menu
		Digital assistant	
	Date & time	Set time automatically	
		Date	
		Time	
		Set automatically	
		Time zone	Region
		Use locale default	Time zone
		Use 24-hour format	
	Windows Ink		
	Display ID		
	Backup		
	System Update		
	Multiple Users	Allow multiple users	
		User	
		Add user	
		Add guest	
		Delete guest activity	
		Add users from lock screen	

Menu	Sub-menu	Menu Option					
<b>System</b>	Reset options	Reset Wi-Fi & Bluetooth					
		Reset app preferences					
		Erase all data (factory rest)					
<b>About Device</b>	Device name						
	Legal information	Third-party license					
		Google legal					
		Google Play system update license					
		System Webview license					
		Wallpaper credits					
		Open source licenses					
	Model	Model					
		Serial number					
		Asset Tagging					
	Android version	Android version					
		Android security update					
		Kernel version					
		Build number					

Menu	Sub-menu	Menu Option
<b>About Device</b>	IP address	
	Ethernet address	
	Wi-Fi MAC address	
	Device Wi-Fi MAC address	
	Bluetooth address	
	Up time	
	Build number	
<b>Tips &amp; Support</b>	myViewBoard 3.0	
	AirSync	
	Manager	
	New features	

# Pre-installed Applications and Settings

## AirSync

Wirelessly share a device's screen to a large display.

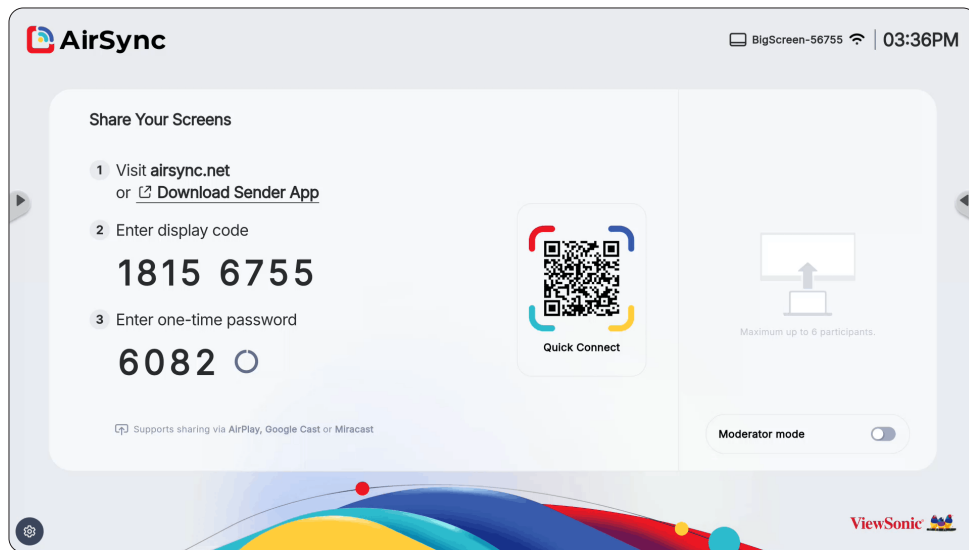

**Note:** To learn more about AirSync, visit the [ViewSonic Apps and ViewBoard Knowledge Base](#).

# Manager

Remotely manage multiple ViewSonic device installations.

**Note:** Only Entity Admins, after logging into myviewboard.com, have access to this feature.

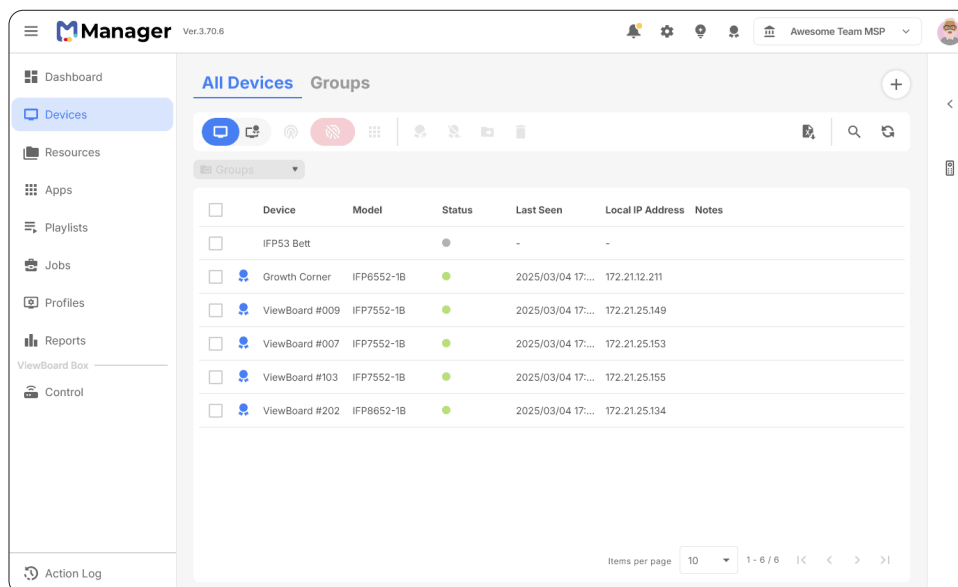

After setting up devices and installing Manager, you can add them to an entity and manage them remotely from the Manager web application.

**Note:** To learn more about Manager, visit the [ViewSonic Apps and ViewBoard Knowledge Base](#).

# myViewBoard

A digital whiteboarding application.

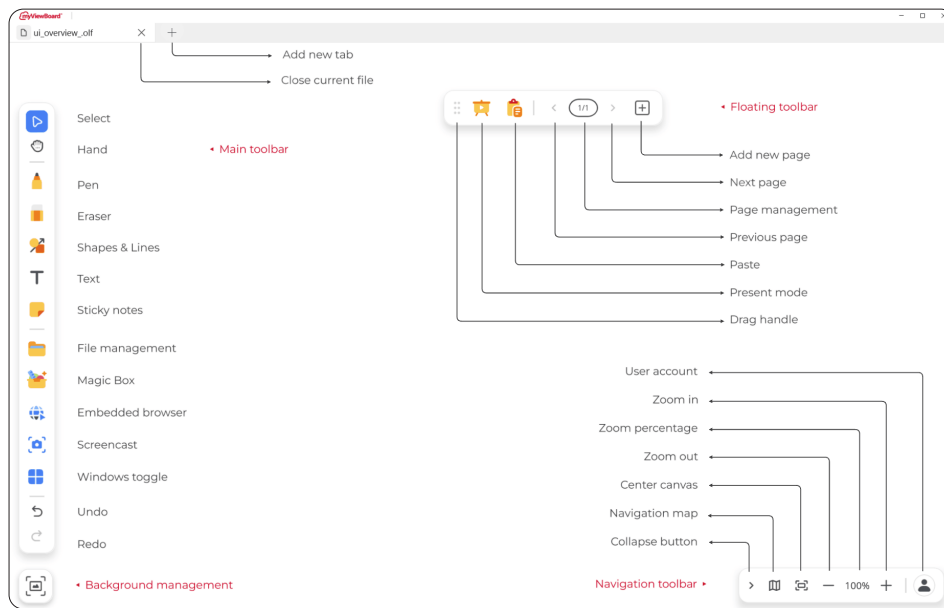

**Note:** To learn more about myViewBoard, visit the [ViewSonic Apps and ViewBoard Knowledge Base](#).

# RS-232 Protocol

This document describes the hardware interface and software protocols of RS-232 interface communication between the ViewSonic LED Display and computers or other control units with RS-232 protocol.

The protocol contains three command sections:

- Set-Function
- Get-Function
- Remote control pass-through mode

**Note:** Below, “PC” represents all the control units that can send or receive the RS-232 protocol command.

## Description

### RS-232 Hardware Specification

ViewSonic LFD communication port on the rear side:

1. Connector type: DSUB 9-Pin Male (female or 3.5 mm barrel connector)
2. Use of crossover (null modem) cable for connection
3. Pin Assignment:

Male DSUB 9-Pin  
(preferred)

1 2 3 4 5



6 7 8 9

Female DSUB 9-Pin

5 4 3 2 1



9 8 7 6

3.5 mm barrel connector  
(alternative for limited  
space)



Pin #	Signal	Remark
1	NC	
2	RXD	Input to Display
3	TXD	Output from Display
4	NC	
5	GND	
6	NC	
7	NC	
8	NC	
9	NC	
frame	GND	

Item	Signal	Remark
Tip	TXD	Output from Display
Ring	RXD	Input to Display
Sleeve	GND	

## LAN Hardware Specification

ViewSonic LFD communication port on the rear side:

1. Connector type: 8P8C RJ45
2. Pin Assignment:

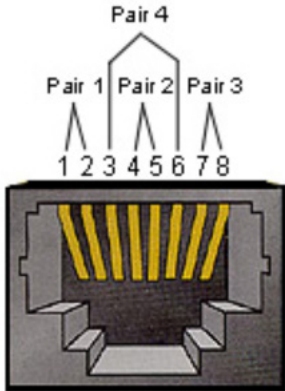

Pin #	Signal	Remark
1	TX+	Output from Display
2	TX-	Output from Display
3	RX+	Input to Display
4	BI_D3+	For 1G case
5	BI_D3-	For 1G case
6	RX-	Input to Display
7	BI_D4+	For 1G case
8	BI_D4-	For 1G case
frame	GND	

## RS-232 Communication Setting

- Baud Rate Select: 9600bps (fixed)
- Data bits: 8 bits (fixed)
- Parity: None (fixed)
- Stop Bits: 1 (fixed)

## LAN Communication Setting

- Type: Ethernet
- Protocol: TCP/IP
- Port: 5000 (fixed)
- WOL Port: 9 (fixed) for UDP\*3.2.0
- Cross subnet: No
- Logon Credentials: No

## Command Message Reference

PC sends to LFD command packet followed by “CR”. Every time PC sends control command to Display, the Display shall respond as follows:

1. If the message is received correctly it will send “+” (02Bh) followed by “CR” (00Dh)
2. If the message is received incorrectly it will send “-” (02Dh) followed by “CR” (00Dh)

# Protocol

## Set-Function Listing

The PC can control the Display for specific actions. The Set-Function command allows you to control the Display behavior at a remote site through the RS-232 port. The Set-Function packet format consists of 9 bytes.

### Set-Function Description:

- Length:** Total Byte of Message excluding "CR"
- LFD ID** Identification for each Display (01~98; default is 01)  
ID "99" means to apply the set command for all connected displays. Under such circumstances, only ID#1 display has to reply.  
The LFD ID can be set via the OSD menu for each Display.
- Command Type** Identify command type,  
"s" (0x73h): Set Command  
"+" (0x2Bh): Valid command Reply  
"- " (0x2Dh): Invalid command Reply
- Command:** Function command code: One byte ASCII code.
- Value[1~3]:** Three bytes ASCII that defines the value.
- CR** 0x0D

### Set-Function Format

#### Send: (Command Type="s")

Name	Length	ID	Command Type	Command	Value1	Value2	Value3	CR
Byte Count	1 Byte	2 Byte	1 Byte	1 Byte	1 Byte	1 Byte	1 Byte	1 Byte
Bytes order	1	2~3	4	5	6	7	8	9

#### Reply: (Command Type="+" or "-")

Name	Length	ID	Command Type	CR
Byte Count	1 Byte	2 Byte	1 Byte	1 Byte
Bytes order	1	2~3	4	5

**Note:** When PC applies command to all displays (ID=99), only the #1 set needs to reply by the name of ID=1.

**Example 1: Set Brightness at 76 for Display (#02) and this command is valid**

**Send (Hex Format)**

Name	Length	ID	Command Type	Command	Value1	Value2	Value3	CR
Hex	0x38	0x30 0x32	0x73	0x24	0x30	0x37	0x36	0x0D

**Reply (Hex Format)**

Name	Length	ID	Command Type	CR
Hex	0x34	0x30 0x32	0x2B	0x0D

**Example 2: Set Brightness at 75 for Display (#02) and this command is NOT valid**

**Send (Hex Format)**

Name	Length	ID	Command Type	Command	Value1	Value2	Value3	CR
Hex	0x38	0x30 0x32	0x73	0x24	0x30	0x37	0x35	0x0D

**Reply (Hex Format)**

Name	Length	ID	Command Type	CR
Hex	0x34	0x30 0x32	0x2D	0x0D

## Set-Function Table

### A. Basic Function

Set Function	Length	ID	Command		Value Range	Comments
			Type (ASCII)	Code (ASCII) Code (Hex)		
Power ON *3.2.1/ OFF (standby)	8		s	!	21 000: STBY 001: ON	1. The Power-on via LAN control may work only under specific modes. See display UG for details. *3.1.1 2. "WOL by MAC address" maybe available as an alternative.*3.2.1
Input Select	8		s	"	22 000: TV 001: AV 002: S-Video 003: YPbPr 004: HDMI1 014: HDMI2 024: HDMI3 034: HDMI4 005: DVI 006: VGA1 016: VGA2 026: VGA3 007: Slot-in PC (OPS/SDM)/HDBT 008: Internal memory 009: DP1 *3.2.4 023: DP2 019: Type-C 1 *3.3.2 039: Type-C 2 00A: Embedded/Main (Android)	1. No need for USB 2. For the case of two or more same sources, the 2nd digital is used to indicate the extension. 3. The HEX of 00A is 30 30 41. 4. 00Z is reserved for cycle mode *3.3.1 5. Using 2nd digi to identify DP or Type C. 0 and even numbers stand for DP; odd numbers stand for Type C *3.3.2
Brightness	8		s	\$	24 000 ~ 100 900: Bright down (-1) 901: Bright up (+1) *3.1.1	
Backlight *3.2.0	8		A	B	42 000 ~ 100	1. For Android platform whose main mode is controlled by backlight and the other sources are controlled by brightness. 2. Derived from Color calibration. *3.2.0
Power lock	8		s	4	34 000: Unlock 001: Lock	*See note in details
Volume	8		s	5	35 000 ~ 100 900: Volume down(-1) 901:Volume up(+1)	
Mute	8		s	6	36 000: OFF 001: ON (mute)	
Button lock	8		s	8	38 000: Unlock 001: Lock	*See note in details
Menu lock	8		s	>	3E 000: Unlock 001: Lock	*See note in details

Set Function	Length	ID	Command	Command	Value Range	Comments	
Number *3.1.1	8		s	@	40	000~009	
Key Pad *3.1.1	8		s	A	41	000: UP 001: DOWN 002: LEFT 003: RIGHT 004: ENTER 005: INPUT 006: MENU/(EXIT) 007: EXIT	
Remote Control	8		s	B	42	000: Disable 001: Enable 002: Pass through	<b>Disable:</b> RCU will have no function <b>Enabled:</b> RCU controls normally <b>Pass through:</b> Display will bypass the RC code to connected device via the RS-232 port, but not react itself.
Restore default	8		s	~	7E	000	Recover to factory settings

**Note:**

**1. Behavior at Lock Modes**

<b>Lock Mode</b>	<b>Behavior</b>
Button Lock	<ol style="list-style-type: none"><li>1. Lock all buttons on the front panel and RCU, except for “Power”</li><li>2. All the SET functions should be workable via RS-232, even the ones with according hot key in RCU like Mute,...etc.</li></ol>
MENU Lock	<ol style="list-style-type: none"><li>1. Lock the “MENU’ key of front panel and RCU</li><li>2. The Factory and Hospitality modes should not be blocked for the model using MENU-combined key to enter these two modes. Alternative approach will be indicated separately if any limitation by model.</li></ol>
POWER Lock	<ol style="list-style-type: none"><li>1. Lock the “POWER” key on the front and RCU.</li><li>2. The SET_POWER ON/OFF should be workable via RS-232, but does not mean the POWER lock will be released under this case.</li><li>3. Can not be unlocked by reset in OSD setting</li><li>4. Will auto AC power-on in power-lock</li><li>5. Under power-lock, the set will not enter power saving when no PC signal and neither turn off when no other video signals after 15 minutes.</li></ol>
Remote Control Disable	Lock the RCU keys, but keep the front panel buttons workable.

**2. Wake-on-LAN by MAC address as alternative for SET Power on**

(Length=126 Bytes)

<b>6 Bytes</b>	<b>6 Bytes (#1)</b>	<b>6 Bytes (#2)</b>	<b>...</b>	<b>6 Bytes (#16)</b>	<b>24 Bytes</b>
0xFF FF ... FF	MAC address	MAC address	...	MAC address	0x00 00 ... 00

## B. Optional Function

Set Function	Length	ID	Command		Value Range (Three ASCII bytes)	Comments
			Type (ASCII)	Code (ASCII) Code (Hex)		
Contrast	8		s	# 23	000 ~ 100	
Sharpness	8		s	% 25	000 ~ 100	
Color	8		s	& 26	000 ~ 100	
Tint	8		s	' 27	000 ~ 100	
Backlight On_Off	8		s	( 29	000: OFF 001: ON	
Color mode	8		s	) 29	000: Normal 001: Warm 002: Cold 003: Personal	
Surround sound	8		s	- 2D	000: OFF 001: ON	
Bass	8		s	. 2E	000 ~ 100	
Treble	8		s	/ 2F	000 ~ 100	
Balance	8		s	0 30	000 ~ 100	050 is central
Picture Size	8		s	1 31	000: FULL (16:9) 001: NORMAL (4:3) 002: REAL (1:1) *3.1.0	
OSD language	8		s	2 32	000: English 001: French 002: Spanish	Could be extended for more supported languages by model
PIP-Mode	8		s	9 39	000: OFF 001: PIP(POP) 002: PBP	
PIP-Sound select	8		s	: 3A	000: Main 001: Sub	
PIP-Position	8		s	; 3B	000: Up 001: Down 002: Left 003: Right	
PIP-Input	8		s	7 37 *2.9	000: TV 001: AV 002: S-Video 003: YPbPr 004: HDMI1 014: HDMI2 024: HDMI3 034: HDMI4  005: DVI 006: VGA1 016: VGA2 026: VGA3  007: Slot-in PC (OPS/SDM)/HDBT 008: Internal memory 009: DP/Type-C *3.2.4  00A: Embedded/Main (Android)	Value range is same as SET-Input select

Set Function	Length	ID	Command	Command	Value Range	Comments
Tiling-Mode	8		s	P	50	000: OFF 001: ON  (for video wall)
Tiling-Compensation	8		s	Q	51	000: OFF 001: ON  (for video wall) Bezel width compensation
Tiling-H by V Monitors	8		s	R	52	01x~09x: H 0x1~0x9: V  (for video wall) 1. 2nd digital for H monitors 2. 3rd digital for V monitors
Tiling-Position	8		s	S	53	001~025  (for Video wall) Copy the screen of Position# to identified display
Date: Year	8		s	V	56	Y17~Y99  Last 2 digits (20)17~(20)99
Date: Month	8		s	V	56	M01~M12  2 digits
Date: Day	8		s	V	56	D01~D31  2 digits
Time: Hour	8		s	W	57	H00~H23  24-hr format. 2 digits.
Time: Min	8		s	W	57	M00~M59  2 digits
Time: Sec	8		s	W	57	S00~S59  2 digits

**Note:**

**1. Tiling definition of H Monitors, V Monitors, and Position**

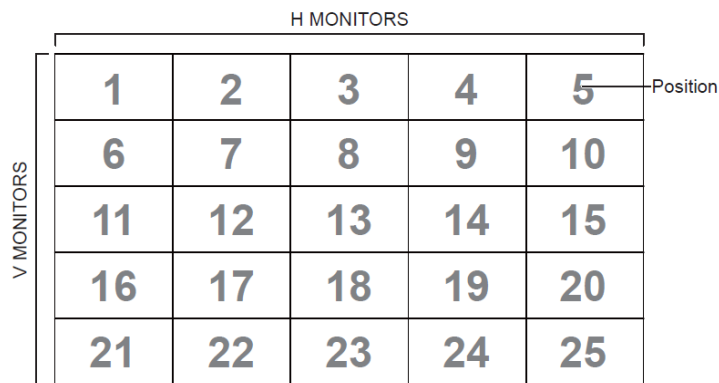

**2. Set Date example**

Date: 2017-3/15

Send: 0x 38 30 31 73 56 59 31 37 0D ("Y17")

Send: 0x 38 30 31 73 56 4D 30 33 0D ("M03")

Send: 0x 38 30 31 73 56 44 31 35 0D ("D15")

**3. Set Time example**

Time: 16:27:59

Send: 0x 38 30 31 73 57 48 31 36 0D ("H16")

Send: 0x 38 30 31 73 57 4D 32 37 0D ("M27")

Send: 0x 38 30 31 73 57 53 35 39 0D ("S59")

## Get-Function Listing

The PC can interrogate the LFD for specific information. The Get-Function packet format consists of 9 bytes which is similar to the Set-Function packet structure. Note that the “Value” byte is always = 000.

### Get-Function Description:

- Length:** Total Byte of Message excluding “CR”.
- TV/DS ID** Identification for each of TV/DS (01~98; default is 01).
- Command Type** Identify command type,  
 “g” (0x67h) : Get Command  
 “r” (0x72h) : Valid command Reply  
 “-” (0x2Dh) : Invalid command Reply
- Command:** Function command code: One byte ASCII code.
- Value[1~3]:** Three bytes ASCII that defines the value.
- CR** 0x0D

### Get-Function Format

Send: (Command Type=“g”)

Name	Length	ID	Command Type	Command	Value1	Value2	Value3	CR
Byte Count	1 Byte	2 Byte	1 Byte	1 Byte	1 Byte	1 Byte	1 Byte	1 Byte
Bytes order	1	2~3	4	5	6	7	8	9

Reply: (Command Type=“r” or “-”)

If the Command is valid, Command Type = “r”

Name	Length	ID	Command Type	Command	Value1	Value2	Value3	CR
Byte Count	1 Byte	2 Byte	1 Byte	1 Byte	1 Byte	1 Byte	1 Byte	1 Byte
Bytes order	1	2~3	4	5	6	7	8	9

If the Command is NOT valid, Command Type = “-”

Name	Length	ID	Command Type	CR
Byte Count	1 Byte	2 Byte	1 Byte	1 Byte
Bytes order	1	2~3	4	5

**Example 1: Get Brightness from TV-05 and this command is valid. The Brightness value is 67.**

**Send (Hex Format)**

Name	Length	ID	Command Type	Command	Value1	Value2	Value3	CR
Hex	0x38	0x30 0x35	0x67	0x62	0x30	0x30	0x30	0x0D

**Reply (Hex Format)**

Name	Length	ID	Command Type	Command	Value1	Value2	Value3	CR
Hex	0x38	0x30 0x35	0x72	0x62	0x30	0x36	0x37	0x0D

**Example 2: Get Color from Display (#05), but the Color command is not supported by this model.**

**Send (Hex Format)**

Name	Length	ID	Command Type	Command	Value1	Value2	Value3	CR
Hex	0x38	0x30 0x35	0x67	0x26	0x30	0x30	0x30	0x0D

**Reply (Hex Format)**

Name	Length	ID	Command Type	CR
Hex	0x34	0x30 0x35	0x2D	0x0D

# Get-Function Table

## A. Basic Function

Get Function	Length	ID	Command		Response Range (Three ASCII bytes)	Comments
			Type (ASCII)	Code (ASCII) Code (Hex)		
Get-Brightness	8		g	b 62	000 ~ 100	
Get-Backlight *3.2.0	8		a	B 42	000 ~ 100	1. For Android platform whose main mode is controlled by backlight and the other sources are controlled by brightness. 2. Derived from Color calibration. *3.2.0
Get-Volume	8		g	f 66	000 ~ 100	
Get-Mute	8		g	g 67	000: OFF 001: ON (muted)	
Get-Input select	8		g	j 6A	000~ 100~	1. 1st digit for signal detection: 0 means "no signal"; 1 means "signal detected" 2. 2nd & 3rd digit: See Set-function table
Get-Power status: ON/ STBY	8		g	l 6C	001: ON 000: STBY	
Get-Remote control	S		g	n 6E	000: Disable 001: Enable 002: Pass through	Get RCU mode status
Get-Power lock	8		g	o 6F	000: Unlock 001: Lock	
Get-Button lock	8		g	p 70	000: Unlock 001: Lock	
Get-Menu lock	8		g	l 6C	000: Unlock 001: Lock	
Get-ACK	8		g	z 7A	000	This command is used to test the communication link
Get-Thermal	8		g	0 30	000~100: 0~+100 deg C -01~-99: -1~-99 deg C	
Get-Operation hour *3.2.0	8		g	1 31	000	1. Accumulated hours in 6-digit integer (000,001~ 999,999) *3.2.0 2. Can not be reset when FW update and Factory initiation *3.2.2 3. Reply in new 32-byte format *3.2.0
Get-Device name	8		g	4 34	000	Reply in new 32-byte format *3.2.0

Get Function	Length	ID	Command	Command		Response Range	Comments
Get-MAC address	8		g	5	35	000	(for the models with LAN) Reply in new 32-byte format *3.2.0
Get-IP address *3.2.0	8		g	6	36	000	(for the models with LAN) Reply in new 32-byte format *3.2.0
Get-Serial number *3.2.0	8		g	7	37	000	Reply in new 32-byte format *3.2.0
Get-FW version *3.2.0	8		g	8	38	000	Reply in new 32-byte format *3.2.0

**Note:**

**1. Get Operation Hour example**

Assumed the accumulated operation hour is 123,456 hrs

Send: 0x 38 30 31 67 31 30 30 30 0D (Get Operation hour)

Reply: 0x 32 30 31 72 31 31 32 33 34 35 36 00 00 ... 00 00 0D

**2. Get Device Name example**

Assumed the device name is CDE-5500

Send: 0x 38 30 31 67 34 30 30 30 0D (Get Device Name)

Reply: 0x 32 30 31 72 34 43 44 45 2D 35 35 30 30 00 00 ... 00 00 0D

Assumed the device name is "NMP-302#1"

Send: 0x 38 30 31 67 34 30 30 30 0D (Get Device Name)

Reply: 0x 32 30 31 72 34 4E 4D 50 2D 33 30 32 23 31 00 00 ...00 00 0D

**3. Get MAC address example**

Assumed the MAC address is 00:11:22:aa:bb:cc

Send: 0x 38 30 31 67 35 30 30 30 0D (Get MAC add)

Reply: 0x 32 30 31 72 35 30 30 31 31 32 32 61 61 62 62 63 63 00 00...00 00 0D

**4. Get IP address example**

Assumed the IP address is 192.168.100.2

Send: 0x 38 30 31 67 36 30 30 30 0D (Get IP address)

Reply: 0x 32 30 31 72 36 31 39 32 2E 31 36 38 2E 31 30 30 2E 32 00 00...00 00 0D

**5. Get Serial number example**

Assumed the Serial number is ABC180212345

Send: 0x 38 30 31 67 37 30 30 30 0D (Get Serial number)

Reply: 0x 32 30 31 72 37 41 42 43 31 38 30 32 31 32 33 34 35 00 00...00 00 0D

**6. Get FW version example**

Assumed the FW version is 3.02.001

Send: 0x 38 30 31 67 38 30 30 30 0D (Get FW version)

Reply: 0x 32 30 31 72 38 33 2E 30 32 2E 30 30 31 00 00...00 00 0D

## B. Optional Function

Get Function	Length	ID	Command	Command		Response Range (Three ASCII bytes)	Comments
				Type (ASCII)	Code (ASCII) / Code (Hex)		
Get-Contrast	8		g	a	61	000 ~ 100	
Get-Sharpness	8		g	c	63	000 ~ 100	
Get-Color	8		g	d	64	000 ~ 100	
Get-Tint	8		g	e	65	000 ~ 100	
Get-Backlight On_Off	8		g	h	68	000: OFF 001: ON	
Get-PIP mode	8		g	t	74	000: OFF 001: PIP (POP) 002: PBP	
Get-PIP input	8		g	u	75	000 ~	See Set-input select
Get-Tiling Mode	8		g	v	76	000: OFF 001: ON	(for Video wall)
Get-Tiling Compensation	8		g	w	77	000: OFF 001: ON	(for Video wall) Bezel width compensation
Get-Tiling H by V monitors	8		g	x	78	01x~09x: H monitors 0x1~0x9: V monitors	(for Video wall) 1. 2nd digital for H monitors 2. 3rd digital for V monitors
Get-Tiling position	8		g	y	79	000: OFF 001~025	(for Video wall) Copy the screen of Position# to identified display
Get-Date: Year	8		g	2	32	Y00~Y00	Last 2 digits (20)17~(20)99
Get-Date: Month	8		g	2	32	M00~M00	2 digits
Get-Date: Day	8		g	2	32	D00~M00	2 digits
Get-Time: Hour	8		g	3	33	H00~H00	24-hr format. 2 digits
Get-Time: Min	8		g	3	33	M00~M00	2 digits
Get-Time: Sec	8		g	3	33	S00~S00	2 digits

**Note:**

**1. Get Date example**

Assumed the current date of display#01 as below:

Date: 2017-3/15

Send: 0x 38 30 31 67 32 59 30 30 0D (Get Date:Year)

Reply: 0x 38 30 31 72 32 59 31 37 0D ("Y17")

Send: 0x 38 30 31 67 32 4D 30 30 0D (Get Date:Month)

Reply: 0x 38 30 31 72 32 4D 30 33 0D ("M03")

Send: 0x 38 30 31 67 32 44 30 30 0D (Get Date:Day)

Reply: 0x 38 30 31 72 32 44 31 35 0D ("D15")

**2. Get Time example**

Assumed the current time of display#01 as below:

Time: 16:27:59

Send: 0x 38 30 31 67 33 48 30 30 0D (Get Time:Hour)

Reply: 0x 38 30 31 72 33 48 31 36 0D ("H16")

Send: 0x 38 30 31 67 33 4D 30 30 0D (Get Time:Min)

Reply: 0x 38 30 31 72 33 4D 32 37 0D ("M27")

Send: 0x 38 30 31 67 33 53 30 30 0D (Get Time:Sec)

Reply: 0x 38 30 31 72 33 53 35 39 0D ("S59")

**3. Get RS232 version example**

Assumed the version is 3.0.1

Send: 0x 38 30 31 67 36 30 30 30 0D (Get RS232 version)

Reply: 0x 38 30 31 72 36 33 30 31 0D ("301")

### **C. Auto Reply** \*3.2.1

The display will send out the updated data/status automatically without GET query from the host whenever the following data/status is changed by the user through any of the available ways like: remote control unit, front control panel keys, or touch screen.

- Power On/Off
- Input Select
- Brightness
- Backlight
- Volume
- Mute On/Off

## Remote Control Pass-through Mode

When the PC sets the Display to Remote Control Pass through mode, the Display will send a 7-byte packet (followed by “CR”) in response to remote control unit (RCU) button activation.

In this mode the RCU will have no effect on the Display function. For example: “Volume+” will not change the volume of the Display, but instead only send the “Volume+” code to the PC over the RS-232 port.

### IR Pass Through-Function format

Reply: (Command Type=“p”)

Name	Length	ID	Command Type	RCU Code1 (MSB)	RCU Code2 (LSB)	CR
Byte Count	1 Byte	2 Byte	1 Byte	1 Byte	1 Byte	1 Byte
Bytes order	1	2~3	4	5	6	7

**Example 1: Remote Control Pass-through when “VOL+” key is pressed for Display (#5)**

Send (Hex Format)

Name	Length	ID	Command Type	RCU Code1 (MSB)	RCU Code2 (LSB)	CR
Hex	0x36	0x30 0x35	0x70	0x31	0x30	0x0D

Key	Code (HEX)	Basic *3.1.1	Optional *3.1.1
1	01	V	
2	02	V	
3	03	V	
4	04	V	
5	05	V	
6	06	V	
7	07	V	
8	08	V	
9	09	V	
0	0A	V	
-	0B		V
RECALL (LAST)	0C		V
INFO (DISPLAY)	0D		V
	0E		
ASPECT (ZOOM, SIZE)	0F		V
VOLUME UP (+)	10	V	
VOLUME DOWN (-)	11	V	
MUTE	12	V	
CHANNEL/PAGE UP (+)/ BRIGHTNESS+	13		V
CHANNEL/PAGE DOWN (-)/ BRIGHTNESS-	14		V
POWER	15	V	
SOURCES (INPUTS)	16	V	
	17		
	18		
SLEEP	19		V
MENU	1A	V	
UP	1B	V	
DOWN	1C	V	
LEFT (-)	1D	V	
RIGHT (+)	1E	V	
OK (ENTER, SET)	1F	V	
EXIT	20	V	
	21		
	22		
	23		
	24		
	25		
	26		
	27		
	28		
	29		
	2A		
	2B		

Key	Code (HEX)	Basic *3.1.1	Optional *3.1.1
RED (F1)	2C		V
GREEN (F2)	2D		V
YELLOW (F3)	2E		V
BLUE (F4)	2F		V

**Note:**

1. This IR-pass-through code is different from the RCU key code.
2. Special control sequence for POWER key under IR-pass through mode.
  - 2-1. When Display is OFF and receives the IR POWER code: Display will turn itself ON, then forward the POWER code to the host via RS-232.
  - 2-2. When Display is ON and receives the IR POWER code: Display will forward the POWER code to the host via RS-232, then turn OFF itself.
  - 2-3. When SET-POWER LOCK is enabled, the Display will not respond to POWER key pressing.
3. The VOLUME UP and VOLUME DOWN code will repeatedly output when you press and hold the keys.

# Appendix

## Display Modes

### DisplayPort

Resolution	Refresh Rate (@)
640 x 480	60, 67, 72 Hz
800 x 600	56, 60, 72, 75 Hz
832 x 624	75 Hz
1024 x 768	60, 70, 75 Hz
1152 x 864	75 Hz
1152 x 870	75 Hz
1280 x 720	60 Hz
1280 x 960	60 Hz
1280 x 1024	60, 75 Hz
1360 x 768	60, 85 Hz
1366 x 768	60 Hz
1440 x 900	60 Hz
1600 x 1200	60 Hz
1680 x 1050	60 Hz
1920 x 1080	60 Hz
1920 x 1200	60 Hz
3840 x 2160	25, 30, 50, 60 Hz

## HDMI

Resolution	Refresh Rate (@)
640 x 480	60, 67, 72, 75 Hz
800 x 600	56, 60, 72, 75 Hz
832 x 624	75 Hz
1024 x 768	60, 70, 75 Hz
1152 x 864	75 Hz
1152 x 870	75 Hz
1280 x 720	60 Hz
1280 x 960	60 Hz
1280 x 1024	60, 75 Hz
1360 x 768	60, 85 Hz
1366 x 768	60 Hz
1440 x 900	60 Hz
1600 x 1200	60 Hz
1680 x 1050	60 Hz
1920 x 1080	60 Hz
1920 x 1200	60 Hz
3840 x 2160	25, 30, 50, 60 Hz

## USB Type C

Resolution	Refresh Rate (@)
640 x 480	60, 67, 72 Hz
800 x 600	56, 60, 72, 75 Hz
832 x 624	75 Hz
1024 x 768	60, 70, 75 Hz
1152 x 864	75 Hz
1152 x 870	75 Hz
1280 x 720	60 Hz
1280 x 960	60 Hz
1280 x 1024	60, 75 Hz
1360 x 768	60, 85 Hz
1366 x 768	60 Hz
1440 x 900	60 Hz
1600 x 1200	60 Hz
1680 x 1050	60 Hz
1920 x 1080	60 Hz
1920 x 1200	60 Hz
3840 x 2160	25, 30, 50, 60 Hz

## VGA

Resolution	Refresh Rate (@)
640 x 480	60, 67, 72 Hz
800 x 600	56, 60, 72, 75 Hz
832 x 624	75 Hz
1024 x 768	60, 70, 75 Hz
1152 x 864	75 Hz
1152 x 870	75 Hz
1280 x 720	60 Hz
1280 x 960	60 Hz
1280 x 1024	60, 75 Hz
1360 x 768	60, 85 Hz
1366 x 768	60 Hz
1440 x 900	60 Hz
1600 x 1200	60 Hz
1680 x 1050	60 Hz
1920 x 1080	60 Hz
1920 x 1200	60 Hz

## HDMI Out

Resolution	Refresh Rate (@)
720 x 480	60 Hz
1920 x 1080	60 Hz
3840 x 2160	60 Hz

## Troubleshooting

This section describes some common problems that you may experience when using the ViewBoard.

Problem or Issue	Possible Solutions
Remote Control is not working	<ol style="list-style-type: none"><li>1. Check whether something is obstructing the display's remote control receiver.</li><li>2. Check whether the batteries in the remote control are installed correctly.</li><li>3. Check whether the batteries need to be replaced.</li></ol>
The unit turns off unexpectedly	<ol style="list-style-type: none"><li>1. Check whether Sleep mode is enabled.</li><li>2. Check if there is a power outage in your area.</li><li>3. Turn on the display and see if the problem is with the signal and control system.</li></ol>

## PC Mode

Problem or Issue	Possible Solutions
No PC signal	<ol style="list-style-type: none"><li>1. Check the display settings.</li><li>2. Check the display resolution.</li><li>3. Adjust the Hs &amp; Vs (synchronization) settings using the OSD menu.</li></ol>
Background streaking	<ol style="list-style-type: none"><li>1. Choose auto adjust.</li><li>2. Adjust clock and phase.</li></ol>
Unsupported format	<ol style="list-style-type: none"><li>1. Choose auto adjust.</li><li>2. Adjust clock and phase settings.</li></ol>

## Touch Function

Problem or Issue	Possible Solutions
Touch function does not work	<ol style="list-style-type: none"><li>1. Check that drivers are installed correctly.</li><li>2. Reinstall driver(s).</li><li>3. Check setup and align it.</li><li>4. Check whether the touch pen is working properly.</li></ol>

## Video Not Working Properly

Problem or Issue	Possible Solutions
No picture/ No sound	<ol style="list-style-type: none"><li>1. Check the Power status.</li><li>2. Check the signal cable.</li><li>3. Check that the internal PC is installed correctly.</li></ol>
Picture is unclear or cuts in and out	<ol style="list-style-type: none"><li>1. Check the signal cable.</li><li>2. Check if other electronics are interrupting the signal.</li></ol>
Poor picture	<ol style="list-style-type: none"><li>1. Adjust chroma, brightness, and contrast settings in the menu.</li><li>2. Check the signal cable.</li></ol>

## Audio Not Working Properly

Problem or Issue	Possible Solutions
No sound	<ol style="list-style-type: none"><li>1. Press the Mute/Unmute button.</li><li>2. Adjust the volume.</li><li>3. Check the audio cable.</li></ol>
One speaker only	<ol style="list-style-type: none"><li>1. Adjust the sound balance in the menu.</li><li>2. Check the sound control panel settings of the computer.</li><li>3. Check the audio cable.</li></ol>

# Maintenance

## General Precautions

- Make sure the device is turned off and the power cable is unplugged from the power outlet.
- Never spray or pour any liquid directly onto the screen or case.
- Handle the device with care, as a darker-colored device, if scuffed, may show marks more clearly than a lighter-colored device.
- Do not use the system continuously for long periods of time.

## Cleaning the Screen

- Wipe the screen with a clean, soft, lint-free cloth. This removes dust and other particles.
- If the screen is still not clean, apply a small amount of non-ammonia, non-alcohol based glass cleaner onto a clean, soft, lint-free cloth; then wipe the screen.

## Cleaning the Case

- Use a soft, dry cloth.
- If the case is still not clean, apply a small amount of non-ammonia, non-alcohol based, mild non-abrasive detergent onto a clean, soft, lint-free cloth, then wipe the surface.

## Disclaimer

- ViewSonic® does not recommend the use of any ammonia or alcohol-based cleaners on the display screen or case. Some chemical cleaners have been reported to damage the screen and/or case of the device.
- ViewSonic® will not be liable for damage resulting from use of any ammonia or alcohol-based cleaners.

**Note:** If condensation appears between the glass and the panel, keep the display turned on until the moisture disappears.

# Regulatory and Service Information

## Compliance Information

This section addresses all connected requirements and statements regarding regulations. Confirmed corresponding applications shall refer to nameplate labels and relevant markings on the unit.

### FCC Compliance Statement

This device complies with part 15 of FCC Rules. Operation is subject to the following two conditions: (1) this device may not cause harmful interference, and (2) this device must accept any interference received, including interference that may cause undesired operation. This equipment has been tested and found to comply with the limits for a Class B digital device, pursuant to part 15 of the FCC Rules.

These limits are designed to provide reasonable protection against harmful interference in a residential installation. This equipment generates, uses, and can radiate radio frequency energy, and if not installed and used in accordance with the instructions, may cause harmful interference to radio communications. However, there is no guarantee that interference will not occur in a particular installation. If this equipment does cause harmful interference to radio or television reception, which can be determined by turning the equipment off and on, the user is encouraged to try to correct the interference by one or more of the following measures:

- Reorient or relocate the receiving antenna.
- Increase the separation between the equipment and receiver.
- Connect the equipment into an outlet on a circuit different from that to which the receiver is connected.
- Consult the dealer or an experienced radio/TV technician for help.

**Warning:** You are cautioned that changes or modifications not expressly approved by the party responsible for compliance could void your authority to operate the equipment.

Contains FCC ID: GSS-VS20736

### Industry Canada Statement

CAN ICES (B) / NMB (B)

Contains IC ID: 4280A-VS20736

## CE Conformity for European Countries



The device complies with the EMC Directive 2014/30/EU and Low Voltage Directive 2014/35/EU, Radio Equipment Directive 2014/53/EU and RoHS2 Directive 2011/65/EU & Annex II EU/2015/863.

The full declaration of conformity can be found at the following website:

- [https://www.viewsonicglobal.com/public/products\\_download/safety\\_compliance/IFP/VS20432\\_CE\\_DoC.pdf](https://www.viewsonicglobal.com/public/products_download/safety_compliance/IFP/VS20432_CE_DoC.pdf)
- [https://www.viewsonicglobal.com/public/products\\_download/safety\\_compliance/IFP/VS20640\\_CE\\_DoC.pdf](https://www.viewsonicglobal.com/public/products_download/safety_compliance/IFP/VS20640_CE_DoC.pdf)
- [https://www.viewsonicglobal.com/public/products\\_download/safety\\_compliance/IFP/VS20641\\_CE\\_DoC.pdf](https://www.viewsonicglobal.com/public/products_download/safety_compliance/IFP/VS20641_CE_DoC.pdf)
- [https://www.viewsonicglobal.com/public/products\\_download/safety\\_compliance/IFP/VS20434\\_CE\\_DoC.pdf](https://www.viewsonicglobal.com/public/products_download/safety_compliance/IFP/VS20434_CE_DoC.pdf)
- [https://www.viewsonicglobal.com/public/products\\_download/safety\\_compliance/IFP/VS20435\\_CE\\_DoC.pdf](https://www.viewsonicglobal.com/public/products_download/safety_compliance/IFP/VS20435_CE_DoC.pdf)

### The following information is only for EU-member states:

The mark shown to the right is in compliance with the Waste Electrical and Electronic Equipment Directive 2012/19/EU (WEEE). The mark indicates the requirement NOT to dispose of the equipment as unsorted municipal waste, but use the return and collection systems according to local law.

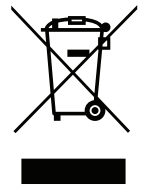

The mark shown to the right is in compliance with the Waste Electrical and Electronic Equipment Directive 2012/19/EU (WEEE). The mark indicates the requirement NOT to dispose of the equipment as unsorted municipal waste, but use the return and collection systems according to local law.



## Declaration of RoHS2 Compliance

This product has been designed and manufactured in compliance with Directive 2011/65/EU of the European Parliament and the Council on restriction of the use of certain hazardous substances in electrical and electronic equipment (RoHS2 Directive) and is deemed to comply with the maximum concentration values issued by the European Technical Adaptation Committee (TAC) as shown below:

Substance	Proposed Maximum Concentration	Actual Concentration
Lead (Pb)	0.1%	< 0.1%
Mercury (Hg)	0.1%	< 0.1%
Cadmium (Cd)	0.01%	< 0.01%
Hexavalent Chromium (Cr6 <sup>+</sup> )	0.1%	< 0.1%
Polybrominated biphenyls (PBB)	0.1%	< 0.1%
Polybrominated diphenyl ethers (PBDE)	0.1%	< 0.1%
Bis (2-ethylhexyl) phthalate (DEHP)	0.1%	< 0.1%
Butyl benzyl phthalate (BBP)	0.1%	< 0.1%
Dibutyl phthalate (DBP)	0.1%	< 0.1%
Diisobutyl phthalate (DIBP)	0.1%	< 0.1%

**Certain components of products as stated above are exempted under the Annex III of the RoHS2 Directives as noted below:**

- Copper alloy containing up to 4% lead by weight.
- Lead in high melting temperature type solders (i.e. lead-based alloys containing 85% by weight or more lead).
- Electrical and electronic components containing lead in a glass or ceramic other than dielectric ceramic in capacitors, e.g. piezoelectronic devices, or in a glass or ceramic matrix compound.
- Lead in dielectric ceramic in capacitors for a rated voltage of 125V AC or 250V DC or higher.

## ENERGY STAR Statement

ENERGY STAR is a U.S. Environmental Protection Agency voluntary program that helps businesses and individuals save money and protect our climate through superior energy efficiency. Products that earn the ENERGY STAR prevent greenhouse gas emissions by meeting strict energy efficiency criteria or requirements set by the U.S. Environmental Protection Agency.

As an ENERGY STAR Partner, ViewSonic is determined to meet the ENERGY STAR Guidelines and mark all certified models with the ENERGY STAR logo.

The following logo appears on all ENERGY STAR-certified models:



**Note:** The power management features significantly reduce energy consumption when the product is not in use. Power management allows the device to automatically enter a low power “sleep” mode after a defined period of inactivity. And the power management features also enter Sleep Mode or Off Mode within 5 minutes of being disconnected from a host computer. Please note any change in energy settings will increase energy consumption.

## Indian Restriction of Hazardous Substances

Restriction on Hazardous Substances statement (India). This product complies with the “India E-waste Rule 2011” and prohibits use of lead, mercury, hexavalent chromium, polybrominated biphenyls or polybrominated diphenyl ethers in concentrations exceeding 0.1 weight % and 0.01 weight % for cadmium, except for the exemptions set in Schedule 2 of the Rule.

## Product Disposal at End of Product Life

ViewSonic® respects the environment and is committed to working and living green. Thank you for being part of Smarter, Greener Computing. Please visit the ViewSonic® website to learn more.

### USA & Canada:

<https://www.viewsonic.com/us/go-green-with-viewsonic>

### Europe:

<https://www.viewsonic.com/eu/environmental-social-governance/recycle>

### Taiwan:

<https://recycle.moenv.gov.tw/>

**For EU users, please contact us for any safety/accident issue experienced with this product:**

ViewSonic Europe Limited

 Flevolaan 38, 1382JZ, Weesp,  
the Netherlands

 +31 08000232999

 [EPREL@viewsoniceurope.com](mailto:EPREL@viewsoniceurope.com)

 <https://www.viewsonic.com/eu/>

## Copyright Information

Copyright© ViewSonic® Corporation, 2026. All rights reserved.

Macintosh and Power Macintosh are registered trademarks of Apple Inc.

Microsoft, Windows, and the Windows logo are registered trademarks of Microsoft Corporation in the United States and other countries.

ViewSonic® and the three birds logo are registered trademarks of ViewSonic® Corporation.

VESA is a registered trademark of the Video Electronics Standards Association. DPMS, DisplayPort, and DDC are trademarks of VESA.

ENERGY STAR® is a registered trademark of the U.S. Environmental Protection Agency (EPA).

As an ENERGY STAR® partner, ViewSonic® Corporation has determined that this product meets the ENERGY STAR® guidelines for energy efficiency.

**Disclaimer:** ViewSonic® Corporation shall not be liable for technical or editorial errors or omissions contained herein; nor for incidental or consequential damages resulting from furnishing this material, or the performance or use of this product.

In the interest of continuing product improvement, ViewSonic® Corporation reserves the right to change product specifications without notice. Information in this document may change without notice.

No part of this document may be copied, reproduced, or transmitted by any means, for any purpose without prior written permission from ViewSonic® Corporation.

## Customer Service

For technical support or product service, see the table below or contact your reseller.

**Note:** You will need the product's serial number.

Country/ Region	Website	Country/ Region	Website
<b>Asia Pacific &amp; Africa</b>			
Australia	<a href="http://www.viewsonic.com/au/">www.viewsonic.com/au/</a>	Bangladesh	<a href="http://www.viewsonic.com/bd/">www.viewsonic.com/bd/</a>
中国 (China)	<a href="http://www.viewsonic.com.cn">www.viewsonic.com.cn</a>	香港 (繁體中文)	<a href="http://www.viewsonic.com/hk/">www.viewsonic.com/hk/</a>
Hong Kong (English)	<a href="http://www.viewsonic.com/hk-en/">www.viewsonic.com/hk-en/</a>	India	<a href="http://www.viewsonic.com/in/">www.viewsonic.com/in/</a>
Indonesia	<a href="http://www.viewsonic.com/id/">www.viewsonic.com/id/</a>	Israel	<a href="http://www.viewsonic.com/il/">www.viewsonic.com/il/</a>
日本 (Japan)	<a href="http://www.viewsonic.com/jp/">www.viewsonic.com/jp/</a>	Korea	<a href="http://www.viewsonic.com/kr/">www.viewsonic.com/kr/</a>
Malaysia	<a href="http://www.viewsonic.com/my/">www.viewsonic.com/my/</a>	Middle East	<a href="http://www.viewsonic.com/me/">www.viewsonic.com/me/</a>
Myanmar	<a href="http://www.viewsonic.com/mm/">www.viewsonic.com/mm/</a>	Nepal	<a href="http://www.viewsonic.com/np/">www.viewsonic.com/np/</a>
New Zealand	<a href="http://www.viewsonic.com/nz/">www.viewsonic.com/nz/</a>	Pakistan	<a href="http://www.viewsonic.com/pk/">www.viewsonic.com/pk/</a>
Philippines	<a href="http://www.viewsonic.com/ph/">www.viewsonic.com/ph/</a>	Singapore	<a href="http://www.viewsonic.com/sg/">www.viewsonic.com/sg/</a>
臺灣 (Taiwan)	<a href="http://www.viewsonic.com/tw/">www.viewsonic.com/tw/</a>	ประเทศไทย	<a href="http://www.viewsonic.com/th/">www.viewsonic.com/th/</a>
Việt Nam	<a href="http://www.viewsonic.com/vn/">www.viewsonic.com/vn/</a>	South Africa & Mauritius	<a href="http://www.viewsonic.com/za/">www.viewsonic.com/za/</a>
<b>Americas</b>			
United States	<a href="http://www.viewsonic.com/us">www.viewsonic.com/us</a>	Canada	<a href="http://www.viewsonic.com/us">www.viewsonic.com/us</a>
Latin America	<a href="http://www.viewsonic.com/la">www.viewsonic.com/la</a>		
<b>Europe</b>			
Europe	<a href="http://www.viewsonic.com/eu/">www.viewsonic.com/eu/</a>	France	<a href="http://www.viewsonic.com/fr/">www.viewsonic.com/fr/</a>
Deutschland	<a href="http://www.viewsonic.com/de/">www.viewsonic.com/de/</a>	Қазақстан	<a href="http://www.viewsonic.com/kz/">www.viewsonic.com/kz/</a>
Россия	<a href="http://www.viewsonic.com/ru/">www.viewsonic.com/ru/</a>	España	<a href="http://www.viewsonic.com/es/">www.viewsonic.com/es/</a>
Türkiye	<a href="http://www.viewsonic.com/tr/">www.viewsonic.com/tr/</a>	Україна	<a href="http://www.viewsonic.com/ua/">www.viewsonic.com/ua/</a>
United Kingdom	<a href="http://www.viewsonic.com/uk/">www.viewsonic.com/uk/</a>		

## Limited Warranty

### ViewSonic® Smart White Board

#### What the warranty covers:

ViewSonic® warrants its products to be free from defects in material and workmanship during the warranty period. If a product proves to be defective in material or workmanship during the warranty period, ViewSonic® will, at its sole option, and as your sole remedy, repair or replace the product with a similar product. Replacement Product or parts may include remanufactured or refurbished parts or components. The repair or replacement unit or parts or components will be covered by the balance of the time remaining on the customer's original limited warranty and the warranty period will not be extended. ViewSonic® provides no warranty for any third-party software whether included with the product or installed by the customer, installation of any unauthorized hardware parts or components (e.g. Projector Lamps). (Please refer to: "What the warranty excludes and does not cover" section).

#### Who the warranty protects:

This warranty is valid only for the first consumer purchaser.

#### What the warranty excludes and does not cover:

- Any product on which the serial number has been defaced, modified, or removed.
- Damage, deterioration, or malfunction resulting from:
  - » Accident, misuse, neglect, fire, water, lightning, or other acts of nature, unauthorized product modification, or failure to follow instructions supplied with the product.
  - » Repair or attempted repair by anyone not authorized by ViewSonic®.
  - » Damage to or loss of any programs, data, or removable storage media.
  - » Normal wear and tear.
  - » Removal or installation of the product.
- Software or data loss occurring during repair or replacement.
- Any damage of the product due to shipment.
- Causes external to the product, such as electric power fluctuations or failure.
- Use of supplies or parts not meeting ViewSonic's specifications.
- Failure of owner to perform periodic product maintenance as stated in the User Guide.
- Any other cause which does not relate to a product defect.

- Damage caused by static (non-moving) images displayed for lengthy periods of time (also referred to as image burn-in).
- Software - Any third-party software included with the product or installed by the customer.
- Hardware/Accessories/Parts/Components – Installation of any unauthorized hardware, accessories, consumable parts or components (e.g. Projector Lamps).
- Damage to, or abuse of, the coating on the surface of the display through inappropriate cleaning as described in the product User Guide.
- Removal, installation, and set-up service charges, including wall-mounting of the product.

### **How to get service:**

- For information about receiving service under warranty, contact ViewSonic® Customer Support (Please refer to the “Customer Service” page). You will need to provide your product’s serial number.
- To obtain warranty service, you will be required to provide: (a) the original dated sales slip, (b) your name, (c) your address, (d) a description of the problem, and (e) the serial number of the product.
- Take or ship the product, freight prepaid, in the original container to an authorized ViewSonic® service center or ViewSonic®.
- For additional information or the name of the nearest ViewSonic® service center, contact ViewSonic®.

### **Limitation of implied warranties:**

There are no warranties, express or implied, which extend beyond the description contained herein including the implied warranty of merchantability and fitness for a particular purpose.

**Exclusion of damages:**

ViewSonic's liability is limited to the cost of repair or replacement of the product. ViewSonic® shall not be liable for:

- Damage to other property caused by any defects in the product, damages based upon inconvenience, loss of use of the product, loss of time, loss of profits, loss of business opportunity, loss of goodwill, interference with business relationships, or other commercial loss, even if advised of the possibility of such damages.
- Any other damages, whether incidental, consequential or otherwise.
- Any claim against the customer by any other party.
- Repair or attempted repair by anyone not authorized by ViewSonic®.

**Effect of state law:**

This warranty gives you specific legal rights, and you may also have other rights which vary from state to state. Some states do not allow limitations on implied warranties and/or do not allow the exclusion of incidental or consequential damages, so the above limitations and exclusions may not apply to you.

**Sales outside the U.S.A. and Canada:**

For warranty information and service on ViewSonic® products sold outside of the U.S.A. and Canada, contact ViewSonic® or your local ViewSonic® dealer.

The warranty period for this product in mainland China (Hong Kong, Macao, and Taiwan Excluded) is subject to the terms and conditions of the Maintenance Guarantee Card.

For users in Europe and Russia, full details of warranty provided can be found at: <http://www.viewsonic.com/eu/> under "Support/Warranty Information".

## **Mexico Limited Warranty**

### ViewSonic® Smart White Board

#### **What the warranty covers:**

ViewSonic® warrants its products to be free from defects in material and workmanship, under normal use, during the warranty period. If a product proves to be defective in material or workmanship during the warranty period, ViewSonic® will, at its sole option, repair or replace the product with a like product. Replacement product or parts may include remanufactured or refurbished parts or components & accessories.

#### **Who the warranty protects:**

This warranty is valid only for the first consumer purchaser.

#### **What the warranty excludes and does not cover:**

- Any product on which the serial number has been defaced, modified or removed.
- Damage, deterioration, or malfunction resulting from:
  - » Accident, misuse, neglect, fire, water, lightning, or other acts of nature, unauthorized product modification, unauthorized attempted repair, or failure to follow instructions supplied with the product.
  - » Causes external to the product, such as electrical power fluctuations or failure.
  - » Use of supplies or parts not meeting ViewSonic®'s specifications.
  - » Normal wear and tear.
  - » Any other cause which does not relate to a product defect.
- Any product exhibiting a condition commonly known as “image burn-in” which results when a static image is displayed on the product for an extended period of time.
- Removal, installation, insurance, and set-up service charges.

**How to get service:**

For information about receiving service under warranty, contact ViewSonic® Customer Support (Please refer to the attached “Customer Service” page). You will need to provide your product’s serial number, so please record the product information in the space provided below on your purchase for your future use. Please retain your receipt of proof of purchase to support your warranty claim.

**For Your Records**

Product Name: \_\_\_\_\_ Model Number: \_\_\_\_\_

Document Number: \_\_\_\_\_ Serial Number: \_\_\_\_\_

Purchase Date: \_\_\_\_\_ Extended Warranty Purchase? \_\_\_\_\_(Y/N)

If so, what date does warranty expire? \_\_\_\_\_

- To obtain warranty service, you will be required to provide (a) the original dated sales slip, (b) your name, (c) your address, (d) a description of the problem, and (e) the serial number of the product.
- Take or ship the product, in the original container packaging, to an authorized ViewSonic® service center.
- Round trip transportation costs for in-warranty products will be paid by ViewSonic®.

**Limitation of implied warranties:**

There are no warranties, express or implied, which extend beyond the description contained herein including the implied warranty of merchantability and fitness for a particular purpose.

**Exclusion of damages:**

ViewSonic®’s liability is limited to the cost of repair or replacement of the product. ViewSonic® shall not be liable for:

- Damage to other property caused by any defects in the product, damages based upon inconvenience, loss of use of the product, loss of time, loss of profits, loss of business opportunity, loss of goodwill, interference with business relationships, or other commercial loss, even if advised of the possibility of such damages.
- Any other damages, whether incidental, consequential or otherwise.
- Any claim against the customer by any other party.
- Repair or attempted repair by anyone not authorized by ViewSonic®.

Contact Information for Sales & Authorized Service (Centro Autorizado de Servicio) within Mexico:	
<b>Name, address, of manufacturer and importers:</b> México, Av. de la Palma #8 Piso 2 Despacho 203, Corporativo Interpalmas, Col. San Fernando Huixquilucan, Estado de México Tel: (55) 3605-1099 <a href="http://www.viewsonic.com/la/soporte/index.htm">http://www.viewsonic.com/la/soporte/index.htm</a>	
NÚMERO GRATIS DE ASISTENCIA TÉCNICA PARA TODO MÉXICO: 001.866.823.2004	
<b>Hermosillo:</b> Distribuciones y Servicios Computacionales SA de CV. Calle Juarez 284 local 2 Col. Bugambilias C.P: 83140 Tel: 01-66-22-14-9005 E-Mail: <a href="mailto:disc2@hmo.megared.net.mx">disc2@hmo.megared.net.mx</a>	<b>Villahermosa:</b> Compumantenimientos Garantizados, S.A. de C.V. AV. GREGORIO MENDEZ #1504 COL, FLORIDA C.P. 86040 Tel: 01 (993) 3 52 00 47 / 3522074 / 3 52 20 09 E-Mail: <a href="mailto:compumantenimientos@prodigy.net.mx">compumantenimientos@prodigy.net.mx</a>
<b>Puebla, Pue. (Matriz):</b> RENTA Y DATOS, S.A. DE C.V. Domicilio: 29 SUR 721 COL. LA PAZ 72160 PUEBLA, PUE. Tel: 01(52).222.891.55.77 CON 10 LINEAS E-Mail: <a href="mailto:datos@puebla.megared.net.mx">datos@puebla.megared.net.mx</a>	<b>Veracruz, Ver.:</b> CONEXION Y DESARROLLO, S.A DE C.V. Av. Americas # 419 ENTRE PINZÓN Y ALVARADO Fracc. Reforma C.P. 91919 Tel: 01-22-91-00-31-67 E-Mail: <a href="mailto:gacosta@qplus.com.mx">gacosta@qplus.com.mx</a>
<b>Chihuahua:</b> Soluciones Globales en Computación C. Magisterio # 3321 Col. Magisterial Chihuahua, Chih. Tel: 4136954 E-Mail: <a href="mailto:Cefeo@soluglobales.com">Cefeo@soluglobales.com</a>	<b>Cuernavaca:</b> Compusupport de Cuernavaca SA de CV Francisco Leyva # 178 Col. Miguel Hidalgo C.P. 62040, Cuernavaca Morelos Tel: 01 777 3180579 / 01 777 3124014 E-Mail: <a href="mailto:aquevedo@compusupportcva.com">aquevedo@compusupportcva.com</a>
<b>Distrito Federal:</b> QPLUS, S.A. de C.V. Av. Coyoacán 931 Col. Del Valle 03100, México, D.F. Tel: 01(52)55-50-00-27-35 E-Mail : <a href="mailto:gacosta@qplus.com.mx">gacosta@qplus.com.mx</a>	<b>Guadalajara, Jal.:</b> SERVICRECE, S.A. de C.V. Av. Niños Héroe # 2281 Col. Arcos Sur, Sector Juárez 44170, Guadalajara, Jalisco Tel: 01(52)33-36-15-15-43 E-Mail: <a href="mailto:mmiranda@servicrece.com">mmiranda@servicrece.com</a>
<b>Guerrero Acapulco:</b> GS Computación (Grupo Sesicomp) Progreso #6-A, Colo Centro 39300 Acapulco, Guerrero Tel: 744-48-32627	<b>Monterrey:</b> Global Product Services Mar Caribe # 1987, Esquina con Golfo Pérsico Fracc. Bernardo Reyes, CP 64280 Monterrey N.L. México Tel: 8129-5103 E-Mail: <a href="mailto:aydeem@gps1.com.mx">aydeem@gps1.com.mx</a>
<b>MÉRIDA:</b> ELECTROSER Av Reforma No. 403Gx39 y 41 Mérida, Yucatán, México CP97000 Tel: (52) 999-925-1916 E-Mail: <a href="mailto:rrrb@sureste.com">rrrb@sureste.com</a>	<b>Oaxaca, Oax.:</b> CENTRO DE DISTRIBUCION Y SERVICIO, S.A. de C.V. Murguía # 708 P.A., Col. Centro, 68000, Oaxaca Tel: 01(52)95-15-15-22-22 Fax: 01(52)95-15-13-67-00 E-Mail: <a href="mailto:gpotai2001@hotmail.com">gpotai2001@hotmail.com</a>
<b>Tijuana:</b> STD Av Ferrocarril Sonora #3780 L-C Col 20 de Noviembr Tijuana, Mexico	<b>FOR USA SUPPORT:</b> ViewSonic® Corporation 381 Brea Canyon Road, Walnut, CA. 91789 USA Tel: 800-688-6688 E-Mail: <a href="http://www.viewsonic.com">http://www.viewsonic.com</a>

Smart White Board Warranty Term Template In UG

VSC\_TEMP\_2013



**ViewSonic®**