



XTREME SCAN 600 SERIES

XG630, XS630, XG640, XS640,
XG662, XG663, XS662, XS663

USER GUIDE



TABLE OF CONTENTS

Package Contents	4
Optional Charging Accessories	5
Product Information	6
Attaching phone or tablet to the data reader	7
Charge the Battery	8
Power Adapter	8
Powering On/Off	9
Scanning Barcodes	10
Bluetooth Connection Modes	11-12
Bluetooth Connection Roles	13
Data Mode-For SPP Mode Only	14
Bluetooth ReConnection	15

How to setup your scanner:

Download our Companion App	16-18
----------------------------	-------

Setup using Application Mode

Apple®	17-18
Android	19
Windows	20

Can't use Companion App?

How to setup your scanner in Basic Mode

Apple	21
Android	22
Windows	23

Pairing Reset (Bluetooth Connection)	24
Factory Reset	25
Restore Method	26

TABLE OF CONTENTS

Battery Replacement	27-28
Quick Programming	29-34
Status Indicators	35-38
Helpful Resources	39
Battery Warning, Safety, Bluetooth, Compliance & Warranty	40-51

PACKAGE CONTENTS

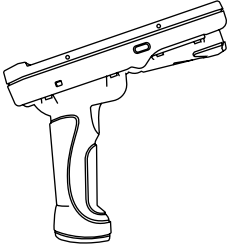

XtremeScan
Mag

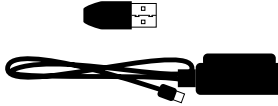

Charging Cable

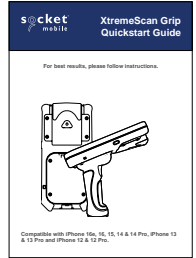

Get Started
Guide

**Thank you for choosing Socket Mobile!
Let's get started!**

© 2025 Socket Mobile, Inc. All rights reserved. Socket®, the Socket Mobile logo, SocketScan®, DuraScan®, Battery Friendly® are registered trademarks or trademarks of Socket Mobile, Inc. Microsoft® is a registered trademark of Microsoft Corporation in the United States and other countries. Apple®, iPad®, iPad Mini®, iPhone®, iPod Touch®, and Mac iOS® are registered trademarks of Apple, Inc., registered in the U.S. and other countries. The Bluetooth® Technology word mark and logos are registered trademarks owned by the Bluetooth SIG, Inc. and any use of such marks by Socket Mobile, Inc. is under license. Other trademarks and trade names are those of their respective owners.

OPTIONAL CHARGING ACCESSORIES

Available separately

For all optional accessories visit our [online store](#).

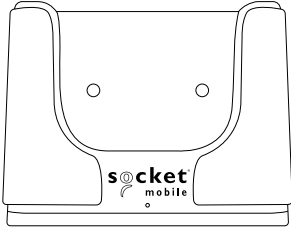

Charging Dock
(coming soon)

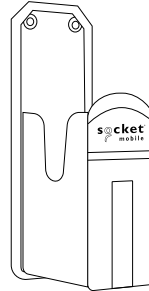

Holster

PRODUCT INFORMATION

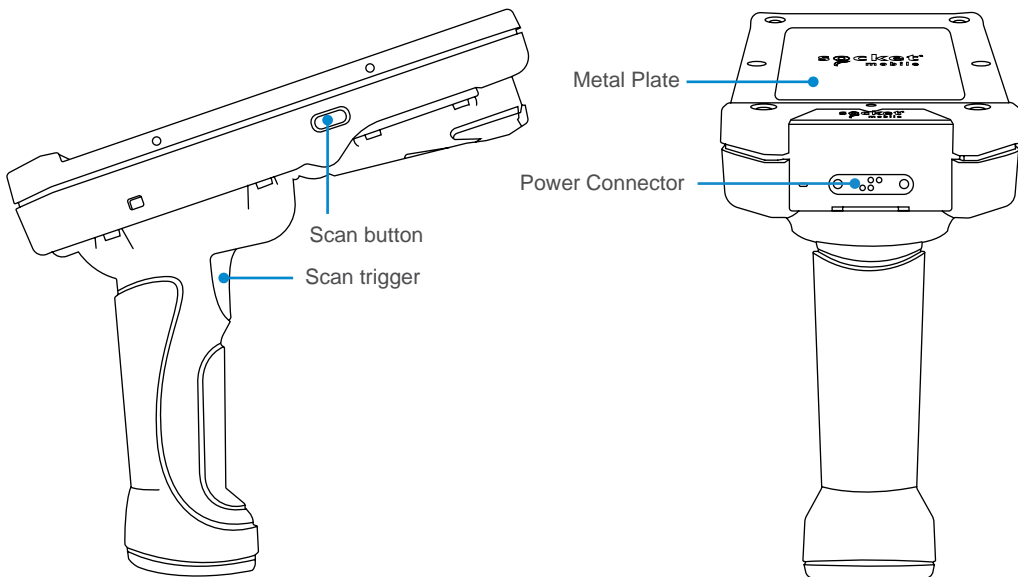

Socket Mobile's barcode readers can be wiped clean with a cloth dampened with isopropyl alcohol or water. Or, the barcode readers can be wiped clean with a Sani-Cloth.

Warning: DO NOT USE BLEACH FOR CLEANING (barcode reader's material property may be affected)

MAGNETIC UNIVERSAL ADAPTER

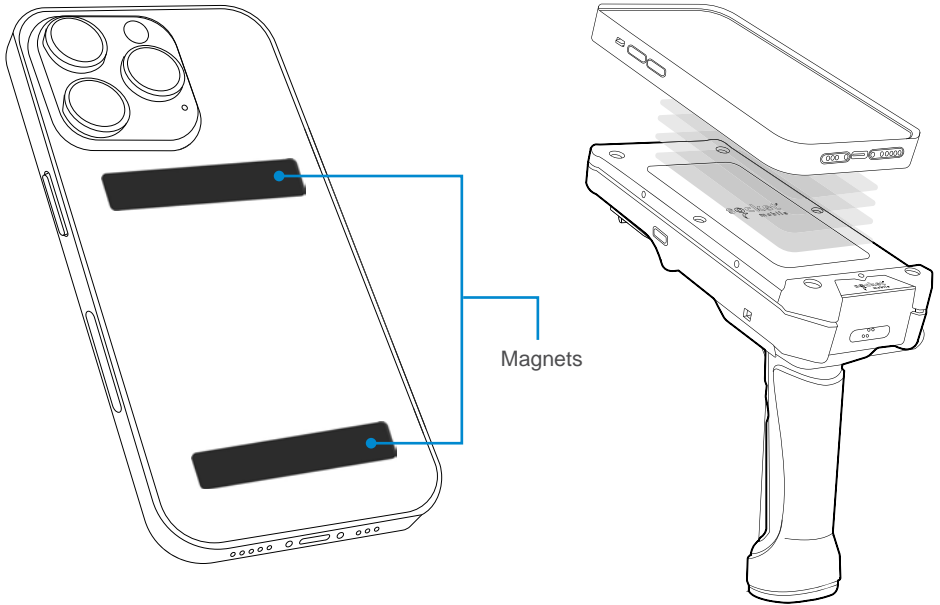



Secure the Magnets (sold separately) with the 3M adhesive onto your device.

Note: We recommend using a magnetic phone case.

Step 2: Secure device to the metal plate.

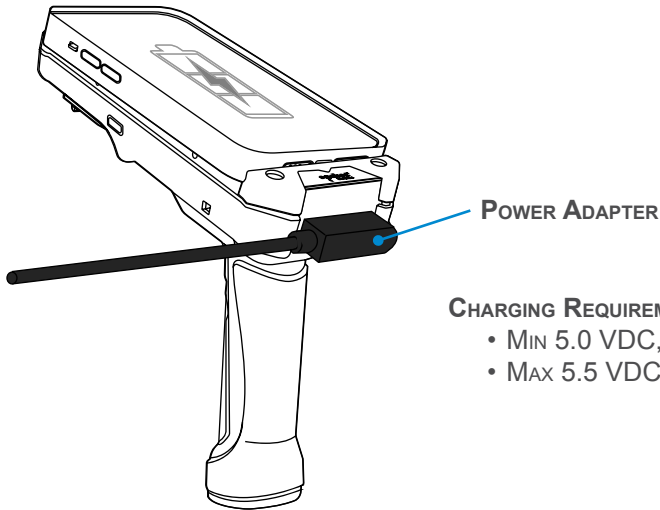
CHARGE THE BATTERY



 **Note:** The reader comes with a pre-installed rechargeable Lithium Ion battery, the initial full charging of the battery can take up to 8 hours.

Plug in the power adapter and the barcode reader will beep twice.

Prior to first use - Fully charge your barcode reader. Use a wall charger to charge battery for 8 hours. Please allow 8 hours uninterrupted charging for the *initial* battery charge.

The barcode reader will stop charging once the battery is full (No overcharging will occur)

- Yellow blinking light = Charging
- Green light = Fully charged

 **Important:** Charging from a computer USB port is not reliable and not recommended.

POWERING ON/OFF

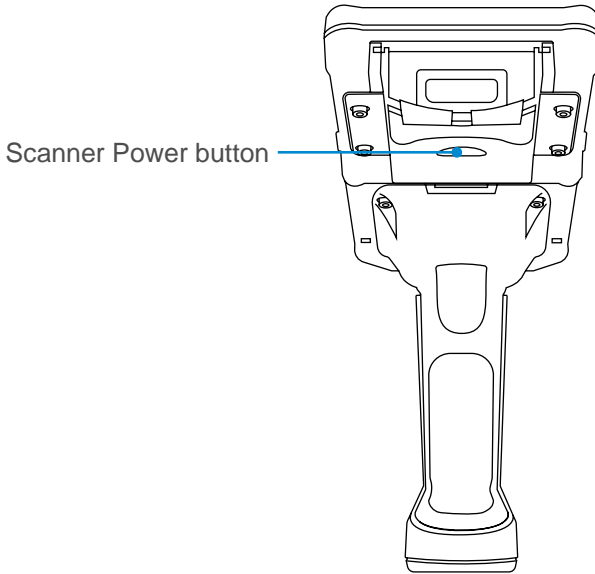

Powering On:

Press and hold down the small power button until the Battery light turns on and the barcode reader beeps twice (low-high).

Powering Off/ Disconnecting:

Press and hold down the small power button until the barcode reader beeps twice (high-low) and all lights turn off.

The barcode reader will power off automatically if device is not connected within 5 minutes. Barcode reader connected to a device will power off within 2 hours if idle/inactive.

SCANNING BARCODES

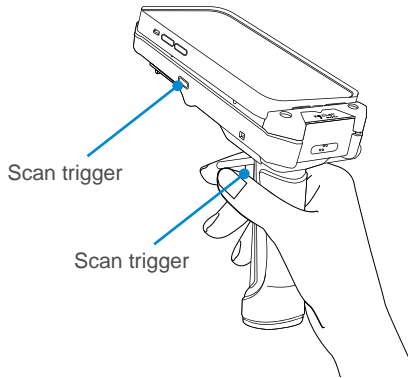
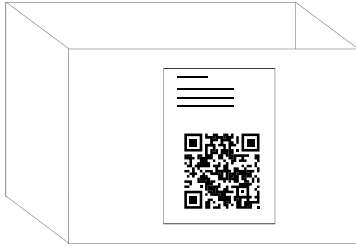

Scanning Barcodes

1. 1.8 in. (4.6 cm) to 19.5 in. (49.5 cm) away from the barcode when using XG640 scanner for 100% UPC Barcodes

Note: Distance between the reader and barcode depend on the reader model and size of the barcode.

2. Aim, press the scan button on the scan application or trigger arm.

By default, the barcode reader will beep, and the scan indicator will flash green to confirm a successful scan.

  **Caution:** Do not stare directly into the barcode reader's light beam.

BLUETOOTH CONNECTION MODES

Operating System Connection Options



Operating Systems (OS)	Devices	Bluetooth HID Support	Bluetooth SPP Support	Bluetooth Apple Serial Specific (MFi Mode)
Android	Android 4.0.3 & later	Yes	Yes	N/A
Apple iOS	iPod, iPhone, & iPad	Yes	N/A	Yes
Windows PC	Windows 10 & later	Yes	Yes	N/A
Mac OS	Mac OS X, Mac Books, Mac Mini, & iMac	Yes	No	N/A

Note: To switch from one mode to the other you must remove the pairing information from both devices - host device and the barcode reader. (see pairing reset procedure on [page 25](#))



Connect your barcode reader using one of the following Bluetooth connection modes:

Bluetooth Connection Profiles

Bluetooth Mode	Description
<p>iOS Application Mode* (Default)</p> <p><small>Made for iPhone iPad iPod</small></p> <p>Use this mode with an Apple app designed for Socket Mobile barcode readers.</p>	<ol style="list-style-type: none"> 1. Use with an App developed for iOS devices 2. Software installation is required 3. Mode to use for iOS applications that support Socket Mobile readers
<p>Android/Windows Application Mode</p> <p></p> <p>Use this mode with an Android app designed for Socket Mobile barcode readers.</p>	<ol style="list-style-type: none"> 1. Software installation is required 2. More efficient and reliable data communications for barcodes containing lots of data 3. Mode recommended for applications supporting Socket Mobile readers
<p>Basic Keyboard Mode</p> <p><small>Made for iPhone iPad iPod</small> </p> <p>Configures the barcode reader to Human Interface Device (HID).</p>	<ul style="list-style-type: none"> • NO software installation needed • Connects to most devices • Good for barcodes containing small amounts of data • Barcode reader interacts with host device like a keyboard

***By default, the barcode reader is set to iOS Application Mode**

Advanced users only.

Note: If using a laser scanner, please print the barcode to scan.

Basic Mode (HID) Keyboard

Changes a barcode reader in HID-Peripheral mode to HID-Keyboard mode.

For Mac OS, Apple iOS, and other smart devices.



Basic Keyboard Mode (HID)

Changes a barcode reader in HID-Keyboard mode to HID-Peripheral mode.

For some MS Windows or Android mobile devices.



Windows PC only: Scan only with barcode reader in Application Mode (SPP).

Acceptor (default)

Configures the barcode reader to accept a Bluetooth connection puts the barcode reader in discoverable mode.



Initiator

Configures the barcode reader to initiate a connection to a computer/device with the Bluetooth Device Address specified in the barcode.

The barcode must be formatted in Code 128 and contain the data #FNlaabbccddeeff# such that aabbccddeeff is the Bluetooth device address of the computer/device you want to connect to the barcode reader.

You must create a custom barcode for each computer/device that you want to connect to the barcode reader.

Advanced users only.

Note: If using a laser scanner, please print the barcode to scan.

Packet Mode (default)

Configures the barcode reader to transmit decoded data in packet format.



Raw Mode - Android and Windows only

Configures the barcode reader to transmit decoded data in raw (unpacketed) format.



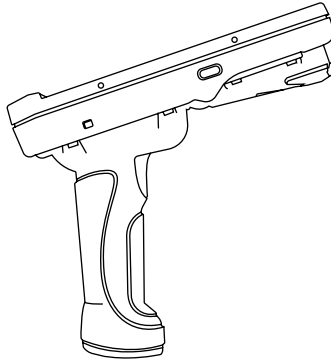

For all Bluetooth Connection Modes.

Note: If using a laser scanner, please print the barcode to scan.

Important! After scanning this command barcode, power off and power on the barcode reader to make sure it is configured properly.

Enable Automatic Reconnection from barcode reader (default)

Configure the barcode reader to automatically initiate a connection to the last paired computer/device after the barcode reader is powered on.



Disable Automatic Reconnection from barcode reader

Configure the barcode reader to wait for a computer/device to initiate a Bluetooth connection after the barcode reader is powered on.



COMPANION APP

Socket Mobile Companion helps you configure Socket Mobile barcode readers from the convenience of a mobile device.



Register a device and extend your warranty by 90 days

- Add multiple devices
- Purchase accessories (limited availability)
- Browse app partners

The Companion app enables you to configure the reader into the faster and more accurate App Mode, so it can be controlled by other apps, such as Shopify and Square, to name a couple of the 1000+ apps available.

The Socket Mobile Companion app is designed to ensure you get the maximum utility benefits from your Socket Mobile devices.

Note: By default, the barcode reader is set to iOS Application Mode

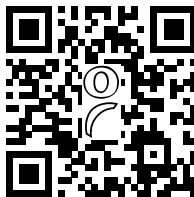

Scan this QR code with your mobile device to download our new app!

Made for
iPhone | iPad | iPod

Scan QR Code using your host device to download Socket Mobile Companion app to pair your barcode reader.



Watch how to set up using the Socket Mobile [Companion](#) app for demonstration.

For quick set up:

Note: If using a laser scanner, please print the barcode to scan.

1. Power on the barcode reader. Make sure the barcode reader is discoverable (unpaired). The Blue light should be blinking fast.
2. Scan barcode. The barcode reader will beep 3 times.



iOS Application Mode

3. Turn on Bluetooth on the Apple device. Go to Settings > Bluetooth. A Bluetooth devices search will begin.
4. Tap Socket M9xx[xxxxxx] in the list of other devices found. After a few seconds the status will change to “Connected” and the barcode reader blue LED will stop blinking and turn solid blue.

Note: The characters in brackets are the last 6 characters of the Bluetooth Address.

5. Launch your barcode reader-enabled Application. The barcode reader will beep once indicating that it is connected to the appropriate application.

Now you are ready to scan barcodes!

Please check with your barcode reader application vendor or visit www.socketmobile.com/appstore to confirm your barcode reader-enabled application supports the barcode reader.

Made for
iPhone | iPad | iPod

In this mode the barcode reader functions and communicates similar to a keyboard. Therefore, barcode reader will work with Safari, Notes, and any other applications that support an active cursor.

1. Power on the barcode reader. Make sure the barcode reader is discoverable (unpaired). The Blue light blinks fast.
2. Scan barcode below.



3. Start a Bluetooth device search.
 - Settings | Bluetooth: Turn on Bluetooth and search for device.
 - Mac OS: Click System Preferences | Bluetooth. A Bluetooth device search will begin.
4. In the device list, tap on M9xx [xxxxxx]. Tap Pair.
5. The barcode reader will connect to the Apple device.
6. The barcode reader will beep once after it has connected.

Now you are ready to scan barcodes!



In this mode the barcode reader functions and communicates similar to a keyboard. Therefore, barcode reader will work with Notes, and any other application that supports an active cursor.

1. Power on the barcode reader. Make sure the barcode reader is discoverable (unpaired) and the blue light blinks fast.
2. Scan barcode below using trigger arm or scan button in application.



3. Settings | Bluetooth.
4. Make sure the device has Bluetooth "On" to scan for devices.
5. In the list of found devices, select M9xx [xxxxxx]. Tap Pair.
6. The barcode reader will connect to the Android device.
7. The barcode reader will beep once after it has connected.

**If you have trouble connecting or pairing with host device, turn host device's Bluetooth off/on, and/or perform factory reset to the barcode reader (see page 23).*

Now you are ready to scan barcodes!

Windows

In this mode the barcode reader functions and communicates similar to a keyboard. Therefore, barcode reader will work with Notes, and any other application that support an active cursor.

1. Turn Bluetooth on for your device. Go to Settings > Bluetooth. A Bluetooth Devices search will begin.
2. Scan barcode below using trigger arm or scan button in application.



3. Tap Socket M9xx[xxxxxx] in the list of Devices found. After a few seconds the status will change to “Connected” or “Paired”, the barcode reader blue light will stop blinking and turn solid blue, and the scanner will emit a single beep to confirm a successful connection.

Now you are ready to scan barcodes!

PAIRING RESET

This procedure will put the barcode reader in discoverable mode.

i If the barcode reader is paired with a device, unpair it before trying to connect to a different device.

Step 1: Remove or forget the barcode reader from the Bluetooth list on the host device.

Step 2: Scan Pairing Reset barcode.

(Note: For the laser barcode reader. Print the barcode to scan).



! **Important:** Both steps above must be done to complete the unpairing.

Alternatively, if you cannot print a barcode, follow the instructions below:

1. Power on the data reader
2. Press and hold the scan button (1)
3. Press and hold the power button (2)
4. Listen for 3 beeps and release
5. Remove (forget) the reader from the Bluetooth list on the host device

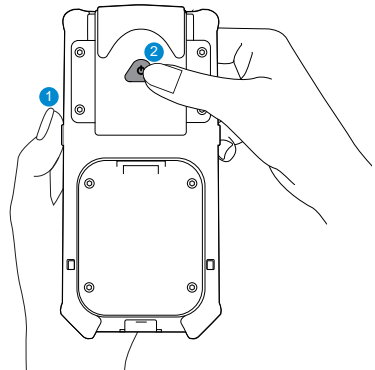
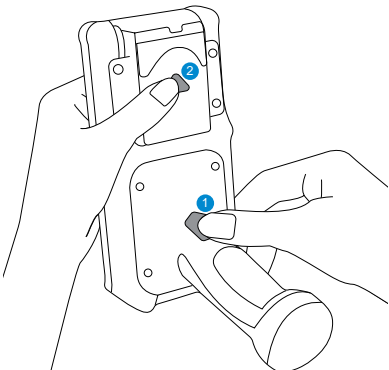

FACTORY RESET

Configures the barcode reader to factory defaults. The barcode reader powers off after scanning this barcode.



Alternatively, if you cannot print a barcode, follow the instructions below:

1. Power on the data reader
2. Press and hold the scan button (1)
3. Press and release the power button (2)
4. Listen for 1 beep and release
5. Release the scan button - the reader will play a tune and shut down.
6. Remove (forget) the reader from the Bluetooth list on the host device.

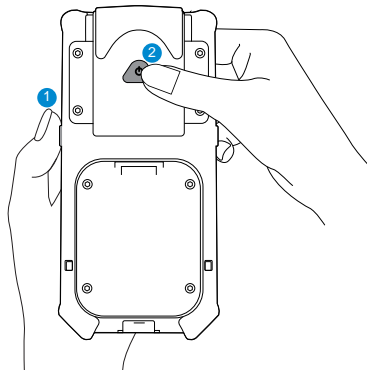
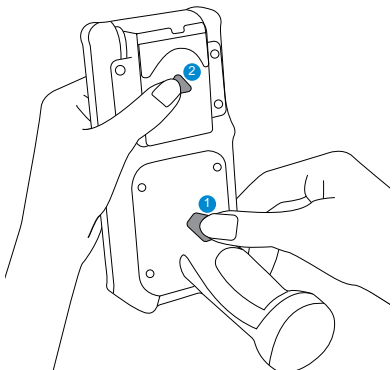

RESTORE METHOD

NOTE: If your barcode reader remains in an unresponsive state after following the Factory Reset, use the Restore Method.

The Restore Method should be the last attempt used to revive an unresponsive barcode reader. It will reinitialize the core hardware.

1. Make sure your barcode reader is OFF.
2. Press and hold the power button until the LED light goes on and off (about 15 seconds)

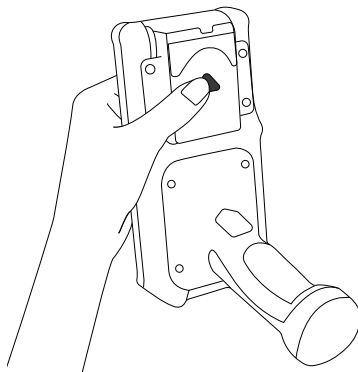

BATTERY REPLACEMENT

Step 1: Remove scan module and battery door

Use the provided allen wrench, remove the four bolts and slide the scan module up. Using the suitable screwdriver (not supplied) remove the battery door.

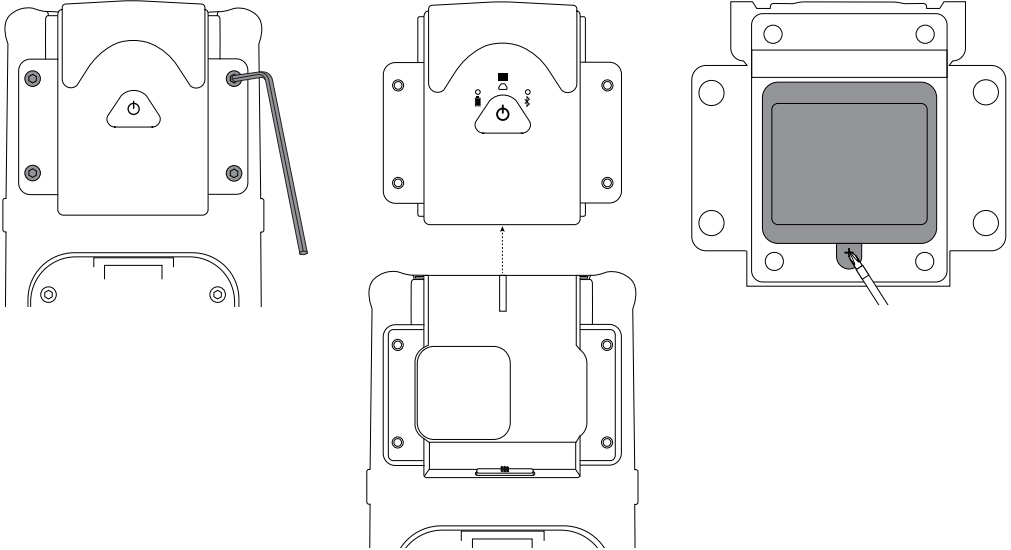

Step 2: Remove old battery and insert new battery

Use a flat head screw driver and place in the top right corner to gently push the battery out. Use only Lithium-Ion Rechargeable batteries. Insert battery and follow battery +/- indicators.

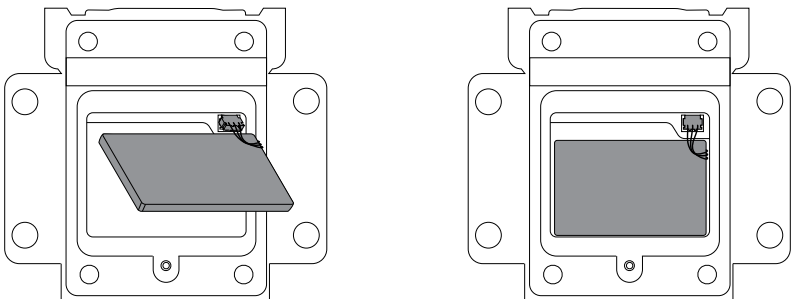

Step 3: Secure battery door

Ensure the battery door is properly placed and tighten the screw, ensuring it is not overtightened.

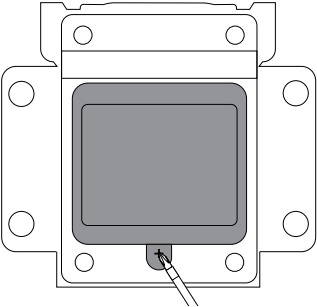

Step 4: Secure the scan module

Insert the scan module and secure with the four allen bolts, being careful not to overtighten.

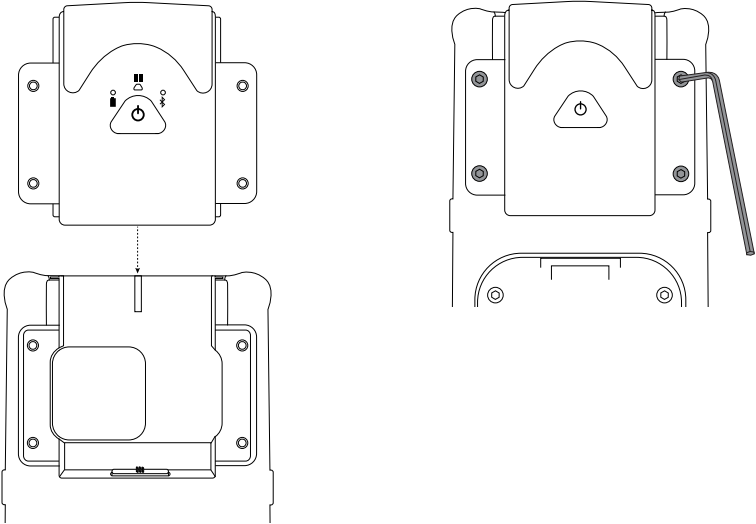





QUICK PROGRAMMING

Scan command barcode(s) to quickly configure the barcode reader.

 **Important!** Make sure the barcode reader is not connected to a host computer or device before scanning a command barcode!



For custom prefix and suffix, please visit <https://sckt.tech/custom-prefix-suffix>

Prefix/Suffix	
Suffix- Carriage Return Configures the barcode reader to add a carriage return after decoded data.	
Suffix- Tab Configures the barcode reader to add a tab after decoded data.	
Suffix- Carriage Return & Line Feed Configures the barcode reader to add a carriage return and line feed after decoded data.	
Data As Is Configures the barcode reader to return only the decoded data. (i.e., no prefix or suffix).	

QUICK PROGRAMMING

SCAN ONE OF THE BARCODES TO ENABLE/DISABLE BEEP SETTINGS.





(NOTE: FOR THE LASER BARCODE READER. PRINT THE BARCODE TO SCAN).

Beep Modes	
Beep ON (default) Enables barcode reader to beep to indicate successful scans.	
Beep OFF Disables barcode reader from beeping to indicate successful scans.	

QUICK PROGRAMMING

SCAN ONE OF THE BARCODES TO RECONFIGURE THE BARCODE READER TO REMAIN POWERED ON FOR A LONGER TIME.

(NOTE: FOR THE LASER BARCODE READER. PRINT THE BARCODE TO SCAN).

Active Modes	
2 Hours (default) Barcode reader powers off in 2 hours when idle/inactive while connected and 5 minutes when disconnected	
Continuous Power for 4 Hours Configures the barcode reader to remain on for 4 hours after last scan.	
Continuous Power for 8 Hours Configures the barcode reader to remain on for 8 hours after last scan.	
Barcode reader Always On Configures the barcode reader to never power off.	



THESE SETTINGS DRAIN THE BATTERY FASTER. PLEASE ENSURE THE BARCODE READER IS CHARGED DAILY.

QUICK PROGRAMMING

These barcodes are to configure the barcode reader for different languages using Microsoft Windows keyboard layout.



Scan only when the barcode reader is in Basic Keyboard Mode (HID profile)**.

(Note: For the laser barcode reader. Print the barcode to scan).

HID Keyboard Language Settings

English (default)



English UK



French



German



Italian



**Does not include XG963, XS963, iXG963, iXS963., XS963, iXG963, iXS963.

QUICK PROGRAMMING

(Note: For the laser barcode reader. Print the barcode to scan).

HID Keyboard Language Settings

Japanese



Polish



Spanish



Swedish



ANSI Emulation
***Can be slower on**
Windows System

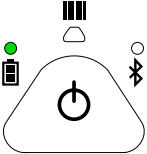
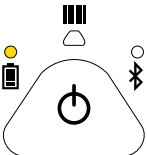

STATUS INDICATORS

Battery Charging when plugged into Power Supply	LED Activity	Meaning
	Blinking Yellow	Charging the battery
	Solid Green	Battery is 100% full
Battery Status When not connected to power supply	LED Activity	Meaning
	Solid Green	Battery capacity from 100% to 26%
	Solid Yellow	Battery capacity from 25% to 10%
	Solid Red	Warning - Battery capacity below 10%
	Blinking Red	The battery level is critically low. Alternatively, if the battery charge status is unknown the battery light will flash red until power is connected and the barcode reader is fully charged.

STATUS INDICATORS

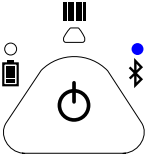
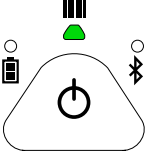
Bluetooth	LED Activity	Meaning
<p data-bbox="78 346 213 377">Bluetooth</p> 	Quick Blinking Blue (2 blinks every second)	Discoverable - waiting for a host Bluetooth connection.
	Slow Blinking Blue (1 blink every second)	Barcode reader is attempting to connect to the last known host device. After 1 minute of blinking, barcode reader will stop searching and omit a long tone.
	No Light - No Activity	Barcode reader has attempted to connect and failed. Press trigger button to try again.
	Solid Blue	Barcode reader is connected
Scan/Read	LED Activity	Meaning
<p data-bbox="78 814 213 845">Scan/Read</p> 	Blink Green Once	Good Scan/Read
	Blink Red Once	Bad Scan/Read
	Solid Red - for as long as power button is pressed	Power Button Pressed

STATUS INDICATORS

Beep Pattern	Sound Meaning
Low-High Tone	Power On
High-Low Tone	Power Off
High-High Tone	Power Supply detected and barcode reader started charging
1 Low Beep	Barcode reader has toggled on-screen keyboard or keyboard toggle feature is enabled (iOS devices only)
1 Beep	Barcode reader connected to device and is ready to scan barcodes
1 Beep	Data successfully scanned
2 Beeps (same tone)	Barcode reader disconnected
1 Long Beep	Barcode reader gave up searching for a host
3 Beeps (escalating tone)	Barcode reader has been reconfigured (the command scanned successfully)
3 Beeps (escalating tone followed by long tone)	The command barcode did NOT work! (Verify if the command barcode used is valid for your barcode reader and try again)

 Command Barcodes are available on page [30](#) to modify beep settings.

 If you are using a barcode reader-enabled application, typically the application provides settings for beep settings.

Configuration Settings

Time after powering on Barcode reader	Bluetooth mode
0-5 minutes	Discoverable and connectable
5 minutes	If connection is not made, barcode reader powers off
2 hours	If your barcode reader is connected but not used it will power off in 2 hours. When scan button is pressed the timer is reset.

HELPFUL RESOURCES

Product specifications, user's guide (full installation and usage instructions) and command barcodes (Advanced Scanner Configurations) can be download at: <https://sckt.tech/downloads>

Technical Support & Product Registration: <https://sckt.tech/support>

- US Toll Free: +1-800-552-3300
- Worldwide: +1-510-933-3000

Warranty Checker: <https://sckt.tech/socketcare>

Socket Mobile Developer Program: <https://sckt.tech/capturesdk>

SAFETY AND HANDLING INFORMATION

 **WARNING:** Failure to follow these safety instructions could result in fire or other injury or damage to the barcode readers or other property.

Carrying and Handling the SocketScan barcode readers: The Socket Mobile barcode reader contains sensitive components. Do not disassemble, open, crush, bend, deform, puncture, shred, microwave, incinerate, paint, or insert foreign objects into this unit.

Do not attempt to disassemble the product. Should your unit need service, contact Socket Mobile technical support at <https://sckt.tech/support>

Changes or modifications of this product, not expressly approved by Socket Mobile may void the user's authority to use the equipment.

Do not charge the SocketScan barcode reader using an AC adapter when operating the unit outdoors, or in the rain.

Operating Temperature - this product is designed for a maximum ambient temperature of 45° degrees C or 113° degrees F.

Pacemaker Disclaimer: For now, we do not have specific information on the effect(s) of vibration or Bluetooth devices on pacemakers. Socket Mobile cannot provide any specific guidance. Individuals who are concerned with using the barcode reader should immediately turn the device off.

Storing - If you are storing your barcode reader for an extended length of time, we recommend removing the battery beforehand to avoid damaging the charging circuit.

FCC ID: LUBMA41



Federal Communication Commission Interference Statement

This equipment has been tested and found to comply with the limits for a Class B digital device, pursuant to Part 15 of the FCC Rules. These limits are designed to provide reasonable protection against harmful interference in a residential installation. This equipment generates, uses and can radiate radio frequency energy and, if not installed and used in accordance with the instructions, may cause harmful interference to radio communications. However, there is no guarantee that interference will not occur in a particular installation.

If this equipment does cause harmful interference to radio or television reception, which can be determined by turning the equipment off and on, the user is encouraged to try to correct the interference by one of the following measures:

- Reorient or relocate the receiving antenna.
- Increase the separation between the equipment and receiver.
- Connect the equipment into an outlet on a circuit different from that to which the receiver is connected.
- Consult the dealer or an experienced radio/TV technician for help.

FCC Caution: To assure continued compliance, any changes or modifications not expressly approved by the party responsible for compliance could void the user's authority to operate this equipment. (Example - use only shielded interface cables when connecting to computer or peripheral devices).

FCC Guidelines for Human Exposure

This equipment complies with FCC radiation exposure limits set forth for an uncontrolled environment.

This equipment should be installed and operated with minimum distance of 20 cm between the radiator and your body.

Radio Frequency Interference Requirements

This device complies with Part 15 of the FCC Rules. Operation is subject to the following two conditions:

1. This device may not cause harmful interference, and
2. This device must accept any interference received, including interference that may cause undesired operation

IC ID: 2529A-MA41X



Industrie
Canada

Industry
Canada

Industry Canada

This Class B digital apparatus complies with Canadian ICES-003

Cet appareil numérique de la classe B est conforme à la norme NMB-003 du Canada

This device complies with Industry Canada license-exempt RSS standard(s).

Operation is subject to the following two conditions: (1) this device may not cause interference and (2) this device must accept any interference, including interference that may cause undesired operation of the device

Le présent appareil est conforme aux CNR d'Industrie Canada applicables aux appareils radio exempts de licence.

L'exploitation est autorisée aux deux conditions suivantes: (1) l'appareil ne doit pas produire de brouillage, et (2) l'utilisateur de l'appareil doit accepter tout brouillage radioélectrique subi, même si le brouillage est susceptible d'en compromettre le fonctionnement"

The radio transmitter has been approved by Industry Canada to operate only with the antenna(s) supplied. Use of any other antenna(s) is strictly prohibited for use with this product.

L'émetteur radio a été approuvé par Industrie Canada pour fonctionner uniquement avec l'antenne(s)

INDUSTRY CANADA RADIATION EXPOSURE STATEMENT MPE/SAR

To comply with RSS-102 requirements, a separation distance of 20 cm must be kept between the device and the user at all times.

Pour se conformer aux exigences RSS-102, une distance de séparation de 20 cm doit être maintenue entre l'appareil et l'utilisateur à tout moment.

CE Marking & European Union Compliance



Products intended for sale within the European Union are marked with a CE Mark, which indicates compliance to applicable Directives and European Normes (EN), as follows. Amendments to these Directives or ENs are included: Normes (EN), as follows:

Applicable Directives:

- RED Directive: 2014/53/EU
- Low Voltage Directives: 2014/35/EU
- EMC Directive: 2014/30/EU
- RoHs Directive: 2015/863
- WEEE Directive: 2012/19/EU

SAFETY: EN 62368-1 Series

UKCA Marking & United Kingdom Compliance

Products intended for sale within the United Kingdom are marked with a UKCA, which indicates conformity to applicable UK directives

- Electromagnetic Compatibility Regulations 2016, SI 2016 No. 1091
- Electrical Equipment Safety Regulations 2016, SI 2016 No. 1101
- Restriction of the Use of Certain Hazardous Substances in Electrical and Electronic Equipment Regulations 2012, SI 2012 No. 3032
- Waste Electric and Electronic Equipment (WEEE) Regulations 2013, SI 2013 No. 3113

Telec Marking Compliance

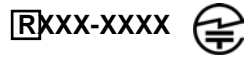

Products intended for sale within the country of Japan are marked with a Telec mark, which indicates compliance to applicable Radio Laws, Articles and Amendments.

BATTERY WARNING STATEMENTS

This device contains rechargeable Lithium-Ion replaceable battery.



Stop charging SocketScan barcode readers if charging is not completed within 24 hours. (Look into replacing the battery).

Stop charging the battery if the SocketScan barcode reader case becomes abnormally hot, or shows signs of odor, discoloration, deformation, or abnormal conditions is detected during use, charge, or storage.

Stop using the SocketScan barcode reader if the enclosure is cracked, swollen or shows any other signs of misuse, discontinue use and email support@socketmobile.com.

Your device contains a rechargeable Lithium-Ion battery which may present a risk of fire or chemical burn if mistreated.

Do not charge in hot temperatures over 40 degrees C or 100 degrees F.

- Never throw the battery into a fire, as that could cause the battery to explode.
- Never short circuit the battery by bringing the terminals in contact with another metal object. This could cause personal injury, or fire, and could also damage the battery.
- Never dispose of used battery with other ordinary solid wastes. Battery contain toxic substances.

CAUTION:

RISK OF EXPLOSION IF BATTERY IS REPLACED BY AN INCORRECT TYPE.
DISPOSE OF USED Battery ACCORDING TO THE INSTRUCTIONS.



- Dispose of used battery in accordance with the prevailing community regulations that apply to the disposal of battery.
- Never expose this product or the battery to any liquids.
- Do not shock the battery by dropping it or throwing it.

If this unit shows any type of damage, such as bulging, swelling or disfigurement, discontinue use and promptly dispose.

Product Disposal

Your device should not be placed in municipal waste. Please check local regulations for disposal of electronic products.

LASER AND LED DEVICES

 **Caution: DO NOT STARE DIRECTLY INTO THE LASER BEAM.**

The following statement is required to comply with US and international regulations:

Caution: Use of controls, adjustments or performance of procedures other than those specified herein may result in hazardous laser beam exposure.

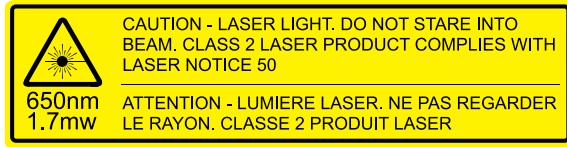

Complies with Laser Notice 50, dated June 24, 2007

Complies with IEC/EN 60825-1:2007, IEC/EN60825-1:2014

Manufacturer Name: Socket Mobile, Inc.

MANUFACTURER ADDRESS: 39700 Eureka Drive, Newark, CA 94560, USA

CE MARKING AND EUROPEAN UNION COMPLIANCE

Testing for compliance to CE requirements was performed by an independent laboratory. The unit under test was found compliant with all the applicable Directives.

WASTE ELECTRICAL AND ELECTRONIC EQUIPMENT

The WEEE directive places an obligation on all EU-based manufacturers and importers to take-back electronic products at the end of their useful life.

NON-MODIFICATION STATEMENT

Changes or modifications not expressly approved by the party responsible for compliance.

CONFORMS TO THE FOLLOWING EUROPEAN DIRECTIVES

Low Voltage Directives: 2014/35/EU

RED Directive: 2014/53/EU

EMC Directive: 2014/30/EU

RoHS Directive: 2015/863

WEEE Directive: 2012/19/EC

Supplementary Information:

Safety: EN 60950-1: 2006/A11:2009, A12:2011, A1:2010, A2:2013

ETSI EN 300 328

ETSI EN 301 489



LIMITED WARRANTY

Socket Mobile Incorporated (Socket) warrants this product against defects in material and workmanship, under normal use and service, for one (1) year from the date of purchase. Product must be purchased new from a Socket Authorized Distributor or Reseller. Used products and products purchased through non-authorized channels are not eligible for this warranty support.

Warranty benefits are in addition to rights provided under local consumer laws. You may be required to furnish proof of purchase details when making a claim under this warranty.

Consumables such as battery, removable cables, cases, straps, and chargers: 90 day coverage only

For more warranty information, please visit: https://sckt.tech/warranty_info



SocketCare Extended Warranty Coverage

Purchase SocketCare within 60 days from the date of purchase of the reader.

Product Warranty: The barcode reader's warranty period is one year from the date of purchase. Consumables such as battery and charging cables have a limited warranty of 90 days. Extend your reader's standard one-year limited warranty coverage up to five years from the date of purchase.

Additional service features are available to further enhance your warranty coverage:

- Warranty period extension only
- Express Replacement Service
- One-Time Accidental Coverage
- Premium Service

For detailed information visit:

<https://sckt.tech/socketcare>