



PCM-B2XT Extra-Large Dual-Sided Ceiling Mount with Advanced Positioning

ITEM: PCM-B2XT

FEATURES

- Components ship pre-assembled for easy installation
- Patented Clevis™ technology provides smooth 12° tilt adjustment for optimal viewing angles
- Built-in Cable Management
- Compatible with Premier Mounts 1.5" NPT products
- Heavy-duty construction for reliable and secure display support



Make a bold statement with the PCM-B2T, our robust dual-sided ceiling mount designed to support extra-large displays up to 85". Ideal for high-impact digital signage in retail, restaurants, and large venues, this turnkey solution allows you to effortlessly suspend two massive displays back-to-back, maximizing your message's reach.

KIT INCLUDES:

PSD-D
CTM-MS3

CEILING SUPPORT AND SUSPENSION ADAPTER ARE NOT INCLUDED!
Must be ordered separately.





PCM-B2XT Extra-Large Dual-Sided Ceiling Mount with Advanced Positioning

SPECIFICATIONS

WEIGHT	COLOR	COMPATIBILITY	WIDTH x HEIGHT x DEPTH
75.3 lbs / 34.16 kg	Black	200mm x 200mm - 900mm x 700mm	36 in x 30.1 in x 9.7 in 91.44 cm x 76.45 cm x 24.64 cm

PRODUCT DIMENSIONS

THE DESIGN, DETAILS, AND THIS DOCUMENT ARE THE PROPERTY OF GAMBER-JOHNSON
PAGE 1 of 1
SCALE 1:10



PART NUMBER:	DESCRIPTION:	WEIGHT (LBS):	RATING (LBS):
PCM-B2XT	CEILING MOUNT, BTB-2, X-LARGE TILT w/ 1.5" NPT + CTM-MS3	75.3	1000

SEE DIMENSIONAL DRAWINGS FOR EACH PART FOR MORE INFORMATION:
- PSD-D
- CTM-MS3

RATING (LBS): 300
PER DISPLAY

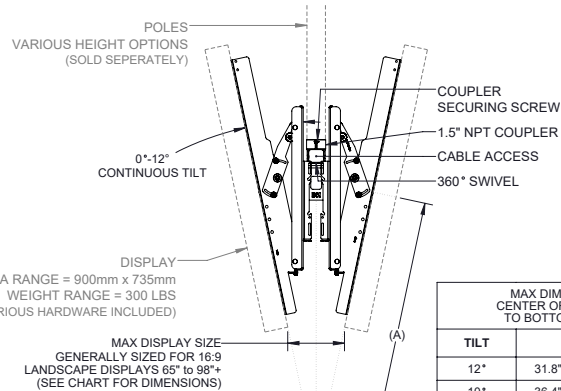
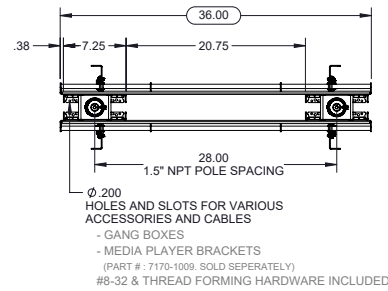

MAX DIMENSION FROM CENTER OF VESA PATTERN TO BOTTOM OF DISPLAY		
TILT	(A)	DISPLAY
12°	31.8" [806.8mm]	98°+
10°	36.4" [924.7mm]	98°+
5°	64.2" [1631mm]	98°+

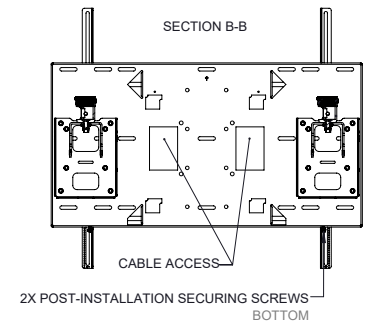
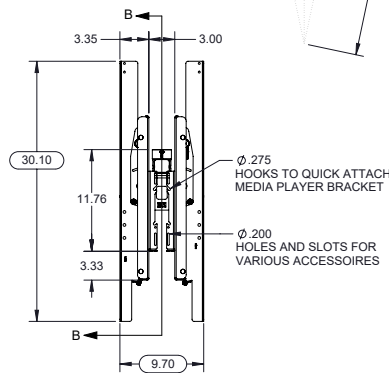
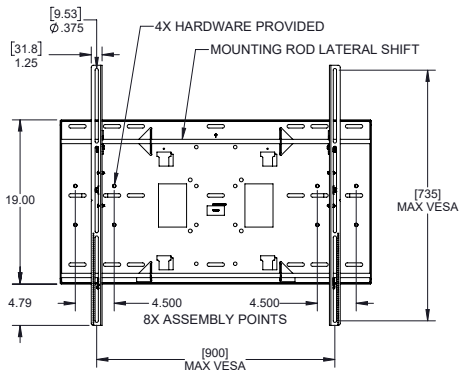

HOW TO BUY

Contact your local sales expert by scanning the QR Code below!



Questions or need more information?
No problem, we're here to help!

Call us at, 1.800.368.9700
Email us at, ORDERS@PREMIERMOUNTS.COM

Visit PREMIERMOUNTS.COM to see our complete line of AV solutions and hang with us on social media at, @PREMIERMOUNTS

We look forward to hanging with you and MOUNT UP.

PREMIER MOUNTS
500 W Central Ave, Suite A
Brea, CA 92821