

DQHD 5120 x 1440 Curved Height Adjustable LED Monitor

L490DQ-HAS

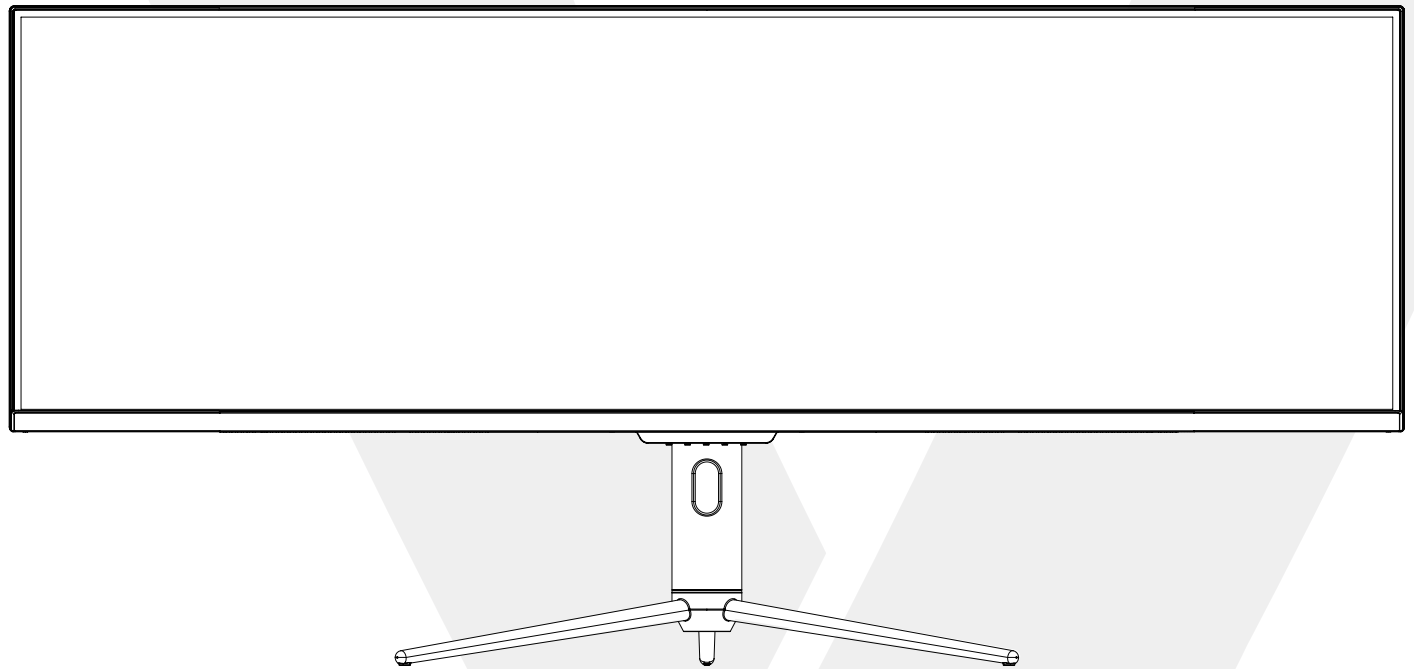

PACKAGE INCLUDES

Package Includes



Monitor

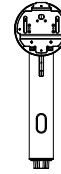

Stand Stem

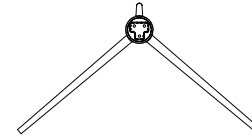

Stand Base

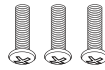

① Stand Screws x 3
(Fixed Base)

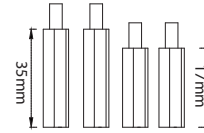

② Mount Screws
(17MM x 2, 35mm x 2)

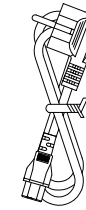

Power Cable

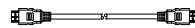

HDMI Cable

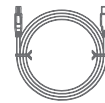

Type-C Cable



USB-B Cable

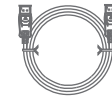

DP Cable

GETTING STARTED

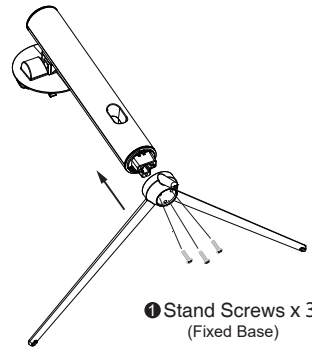
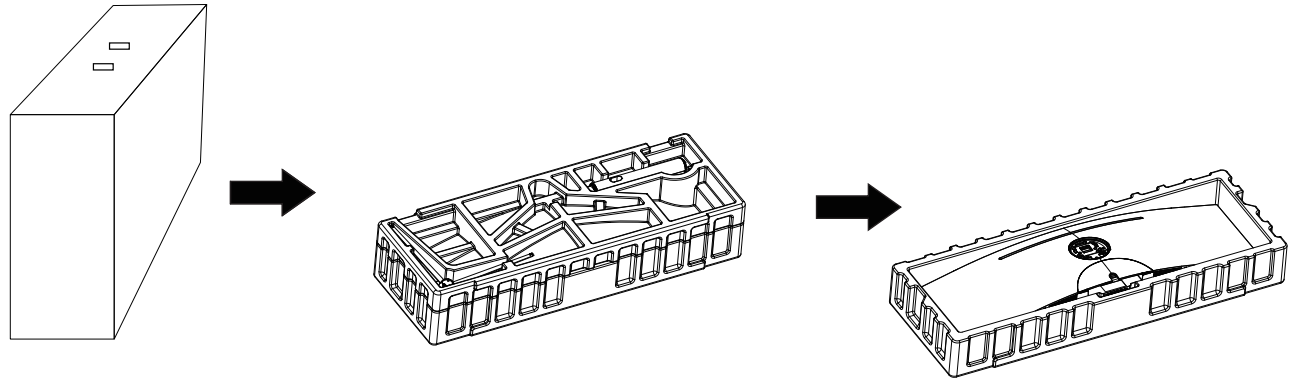

1 Stand Screws x 3
(Fixed Base)

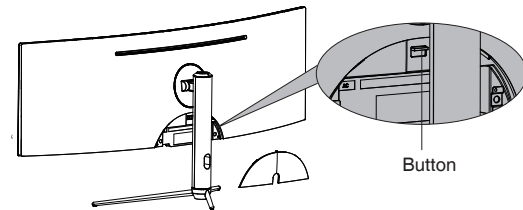
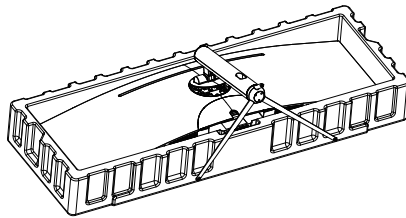
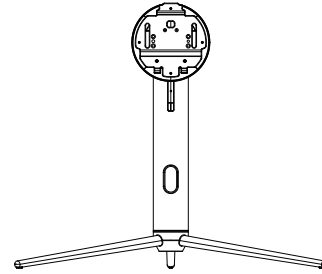

Button

GETTING STARTED

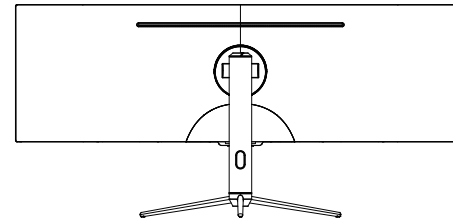
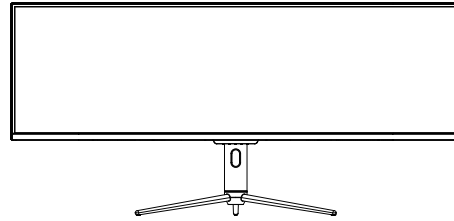

To prevent damage, avoid touching the LCD screen during assembly

Um Schäden zu vermeiden, sollten Sie den LCD-Bildschirm während der Montage nicht berühren
Pour éviter tout dommage, évitez de toucher l'écran LCD pendant l'assemblage
Para evitar daños, evite tocar la pantalla LCD durante el montaje
Per evitare danni, evitare di toccare lo schermo LCD durante il montaggio

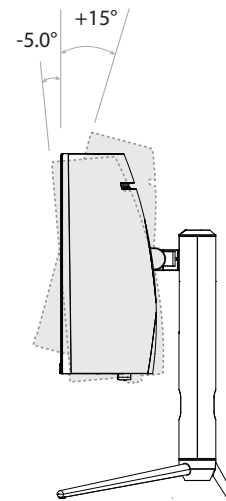
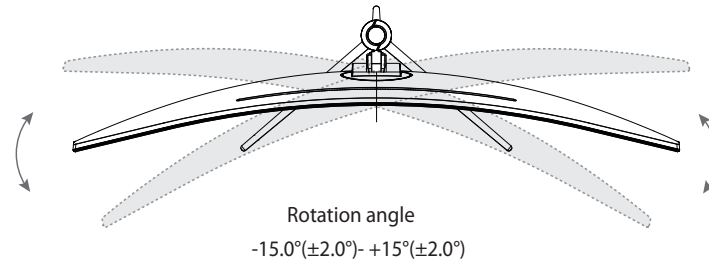

Tilting angle
-5.0°- +15°

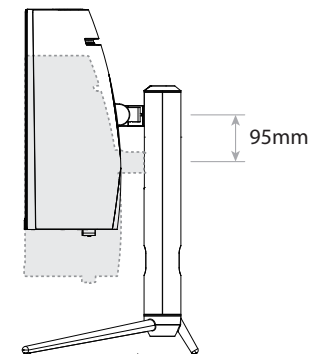

Height adjustment range
95±5mm

Mounting Option

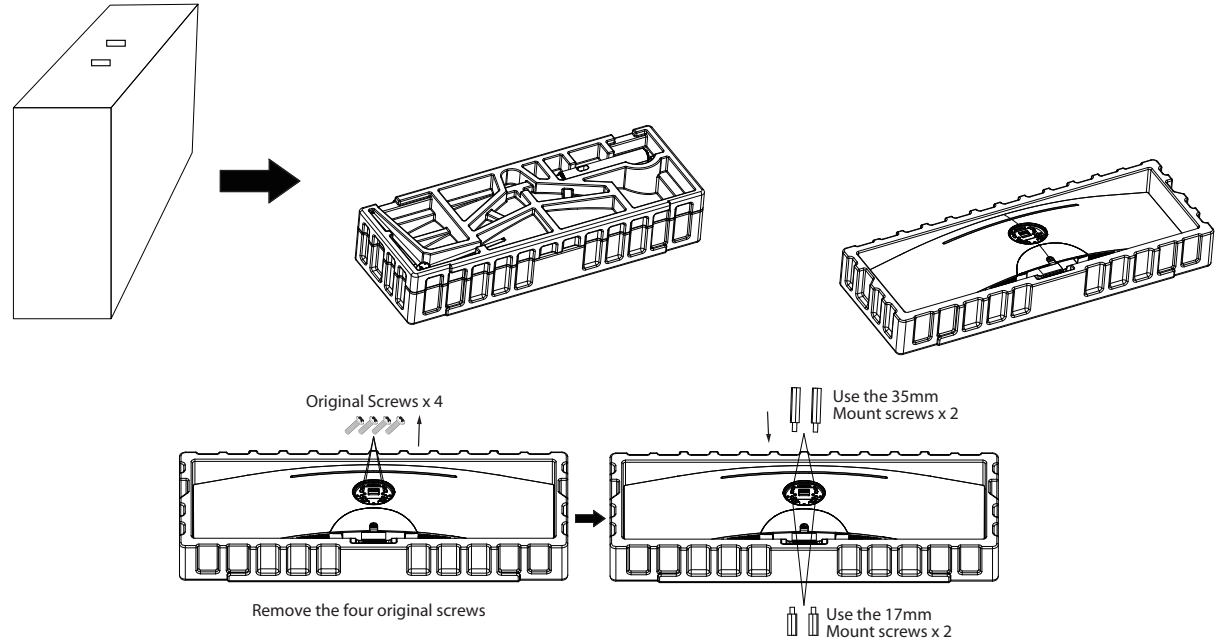

- Remove the 4 original screws from the opening in the back of the monitor
- Install the 2x35mm x 2 x17mm screws into the same opening
- Refer to the image for visual guidance
- Follow the directions included with your mount, stand, or accessory for further assembly instructions

- Entfernen Sie die 4 Originalschrauben aus der Öffnung auf der Rückseite des Monitors.
- Montieren Sie die 2x35mm x 2 x17mm Schrauben in die gleiche Öffnung
- Beachten Sie die Abbildung zur visuellen Orientierung
- Befolgen Sie die mit der Halterung, dem Ständer oder dem Zubehör gelieferten Anweisungen für weitere Montageanweisungen.

- Retirez les 4 vis d'origine de l'ouverture à l'arrière du moniteur.
- Installez les vis 2x35mm x 2 x17mm dans la même ouverture.
- Se référer à l'image pour une aide visuelle
- Suivez les instructions fournies avec votre support, votre socle ou votre accessoire pour plus d'informations sur l'assemblage.

- Retire los 4 tornillos originales de la abertura en la parte posterior del monitor
- Instale los tornillos 2x35mm x 2 x17mm en la misma abertura
- Consulte la imagen como guía visual
- Siga las instrucciones incluidas con el soporte o accesorio para obtener más información sobre el montaje.

- Rimuovere le 4 viti originali dall'apertura sul retro del monitor.
- Installare le viti 2x35mm x 2 x17mm nella stessa apertura
- Fare riferimento all'immagine come guida visiva
- Seguire le istruzioni fornite con il supporto, lo stativo o l'accessorio per ulteriori istruzioni di montaggio.

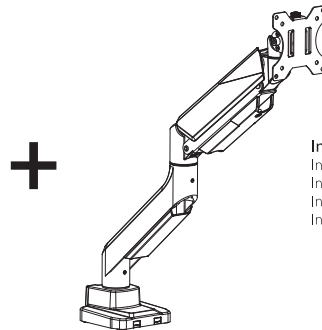

Installing Optional Heavy Duty Monitor Arm DM1HDS – (Sold separately)
Installation des optionalen schweren Monitorarms DM1HDS - (separat erhältlich)
Installation du bras de moniteur robuste DM1HDS en option - (vendu séparément)
Instalación del brazo de monitor resistente opcional DM1HDS - (Se vende por separado)
Installazione del braccio per monitor pesante opzionale DM1HDS - (venduto separatamente)

GETTING STARTED

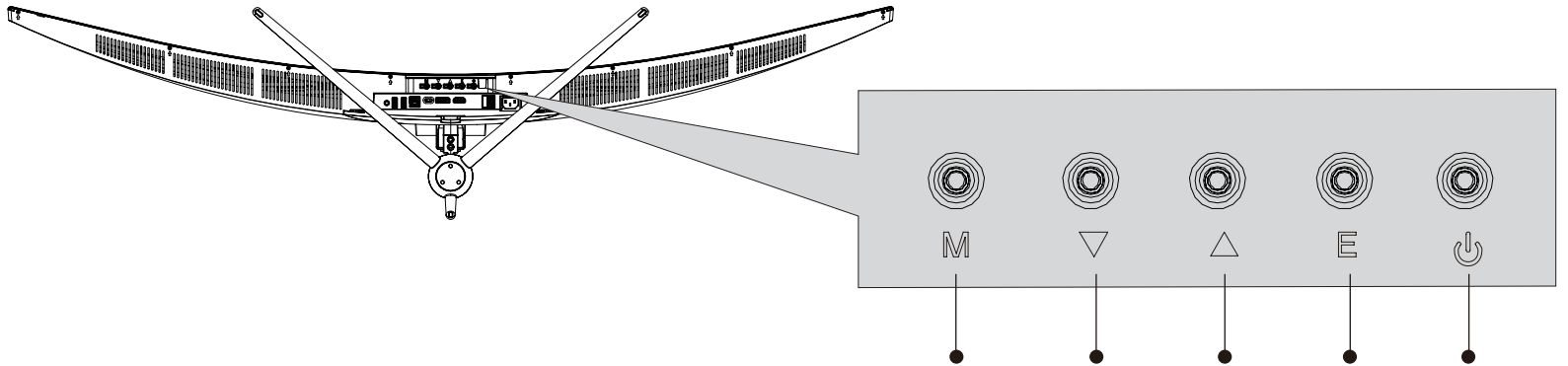
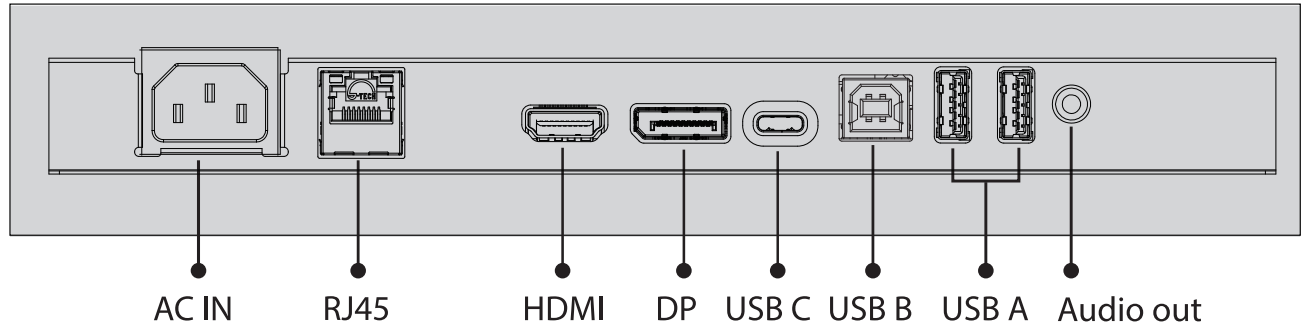



• Press



In power-off mode, press  button to turn on the monitor

In working status, long press  button to turn the monitor to power off mode.

- Drücken Sie

Drücken Sie im Ausschaltmodus die Taste , um den Monitor einzuschalten. Drücken Sie im Arbeitsmodus lange die Taste , um den Monitor auszuschalten.



- Appuyer sur

En mode d'extinction, appuyez sur le bouton  pour allumer le moniteur. En mode de fonctionnement, appuyez longuement sur le bouton  pour mettre le moniteur en mode d'extinction.

- Pulse el botón

En el modo de apagado, pulse el botón  para encender el monitor. En el modo de funcionamiento, mantenga pulsado el botón  para apagar el monitor.

- Premere

In modalità di spegnimento, premere il tasto  per accendere il monitor. In stato di lavoro, premere a lungo il tasto  per portare il monitor in modalità di spegnimento.

• M / ▼ / ▲ / E

When the main menu is displayed on the screen, press **M / ▼ / ▲ / E** button to execute the following functions.

- Press **▼ / ▲** button to move the cursor down/up to select the desired submenu or item, or adjust the value of selected item.
- Press **M** button to access the selected submenu or item.
- Press **E** button to return back to the upper level menu or exit the main menu

Wenn das Hauptmenü auf dem Bildschirm angezeigt wird, drücken Sie die Tasten **M / ▼ / ▲ / E**, um die folgenden Funktionen auszuführen.

- Drücken Sie die Taste **▼ / ▲** um den Cursor nach unten/oben zu bewegen, um das gewünschte Untermenü oder Element auszuwählen, oder um den Wert des ausgewählten Elements anzupassen.
- Drücken Sie die Taste **M**, um das ausgewählte Untermenü oder Element aufzurufen.
- Drücken Sie die Taste **E**, um zum übergeordneten Menü zurückzukehren oder das Hauptmenü zu verlassen.

Lorsque le menu principal est affiché à l'écran, appuyez sur les touches **M / ▼ / ▲ / E** pour exécuter les fonctions suivantes.

- Appuyez sur la touche **▼ / ▲** pour déplacer le curseur vers le bas ou vers le haut afin de sélectionner le sous-menu ou l'élément souhaité, ou pour régler la valeur de l'élément sélectionné.
- Appuyez sur la touche **M** pour accéder au sous-menu ou à l'élément sélectionné.
- Appuyez sur la touche **E** pour revenir au niveau supérieur du menu ou pour quitter le menu principal.

Cuando aparezca el menú principal en la pantalla, pulse los botones **M / ▼ / ▲ / E** para ejecutar las siguientes funciones.

- Pulse el botón **▼ / ▲** para mover el cursor hacia abajo/arriba y seleccionar el submenú o elemento deseado, o para ajustar el valor del elemento seleccionado.
- Pulse el botón **M** para acceder al submenú o elemento seleccionado.
- Pulse el botón **E** para volver al menú de nivel superior o salir del menú principal.

Quando sullo schermo è visualizzato il menu principale, premere i pulsanti **M / ▼ / ▲ / E** per eseguire le seguenti funzioni.

- Premere il tasto **▼ / ▲** per spostare il cursore verso il basso/alto per selezionare il sottomenu o la voce desiderata, oppure per regolare il valore della voce selezionata.
- Premere il pulsante **M** per accedere al sottomenu o alla voce selezionata.
- Premere il pulsante **E** per tornare al menu di livello superiore o per uscire dal menu principale.

ON-SCREEN DISPLAY

Game Settings Spiel-Einstellungen Paramètres du jeu Ajustes del juego Impostazioni di gioco	Standard Mode	Off, On
	RTS/RPG Mode	Off, On
	FPS Arena Mode	Off, On
	MOBA Arena Mode	Off, On
	Adaptive-Sync	Off, On
	Shadow Balance	0-100
	Response Time	Off, Normal, Fast, Ultrafast
	Refresh Rate	Off, On, Window position
	Game Crosshair	Off, On
	Game Time	Off, 15:00, 30:00,45:00, 60:00,Window location
	Dynamic Brightness	Off, Normal, Expert, Elaboration
	HDR	Off/HDR Standard/HDR Movie/HDR RTS/RPG/HDR FPS
	MPRT	Off,On (120Hz Valid)
	Picture Settings Bildeinstellungen Réglages de l'image Ajustes de imagen Impostazioni dell'immagine	Brightness
Contrast		0-100
DCR		Off, On
Contextual model		Off, Movie mode, Reading mode, Night mode , Care Eyes Mode
Low Blue Light		0-100
Sharpness		0-5
Gamma		1.8, 2.0, 2.2, 2.4, 2.6, S.curve
Aspect Ratio		Wide Screen, 4:3, 1:1, Auto
Color Settings Farbeinstellungen Paramètres de couleur Ajustes de color Impostazioni del colore	Warm	Off, On
	Natural	Off, On
	Cool	Off, On
	User1	Off, On (R,G,B)
	User2	Off, On (R,G,B)
	User3	Off, On (R,G,B)
	Hue	0-100 (R,G,B,C,M,Y)
Saturation	0-100 (R,G,B,C,M,Y)	
PIP/PBP	PIP/PBP Mode	Off, PIP Mode,PBP 2Win 1:1,PBP 2Win 2:1,PBP 2Win 1:2
	Sub-Signal Source	Type-C, DP, HDMI
	Audio Source	Auto, Type-C,DP, HDMI
	PIP Position	Top Right,Top Left, Bottom Right, Bottom Left
	PIP Size	Small, Medium, Large
	Window Swap	N/A

OSD Settings OSD-Einstellungen Réglages OSD Ajustes OSD Impostazioni OSD	Language	简体中文, English, 한국어,عربي, Portugues do Brasilazil, Deutsch, Nederland, Suomi, Français, Ελληνικό, Indonesia, Italiano, 日本語, Malaysia, Polskie, Português, Русский, Español, ไทย, Українська, Tiếng Việt, 繁體中文, Türkçe
	OSD Time Out	5-60
	OSD H-Position	0-100
	OSD V-Position	0-100
	OSD Transparency	0-5
	OSD Rotation	Normal, 90, 180, 270
	OSD Lock	Off, On
	Hotkey1 Setting	Brightness, Contrast, Volume, Mute, Shadow Balance, Game Crosshair, Refresh Rate, Game Time, Contextual Model, PIP/PBP Mode, Input Signal, Dynamic Brightness, HDR
	Hotkey2 Setting	
	Hotkey3 Setting	
Other Settings Andere Einstellungen Autres paramètres Otros ajustes Altre impostazioni	Input Signal	Auto, Type-C, DP, HDMI
	Volume	0-100
	Mute	Off, On
	Auto Power	Off, On
	Eyeshield Remind	Off, On
	USB Switch	Type-B, Type-C
	USB Power (Sleep)	Off, On
	USB Upgrade	No, Yes
	Reset	No, Yes
Information	Input Source ,Resolution, Mode, HDR Ver	

TECHNICAL SPECS

General	Allgemein	Général	General	Generale	
Model	Modell	Modèle	Modelo	Modello	L490DQ-HAS
Product Dimensions	Produkt Abmessungen	Dimensions du produit	Dimensiones del producto	Dimensioni del prodotto	119.85x 37.56 x 15.85 cm (47.19 x 14.79 x 6.24 in)
Product Weight	Produktgewicht	Poids du produit	Peso del producto	Peso del prodotto	11.5kg (25.35 lbs)
Package Dimensions	Abmessungen der Verpackung	Dimensions de l'emballage	Dimensiones del embalaje	Dimensioni dell'imballaggio	130.5 x 48.6 x 28.4 cm (51.38 x 19.13 x 11.18 in)
Package Weight	Gewicht der Verpackung	Poids de l'emballage	Peso del embalaje	Peso dell'imballaggio	15.6kg (34.39 lbs)
Technical	Technisch	Technique	Técnico	Technique	
Panel Size	Panel-Größe	Taille du panneau	Tamaño del panel	Dimensione del pannello	49 Inches
Curvature	Kurven	Courbes	Curvas	Bends	1800R
Maximum Resolution	Maximale Auflösung	Résolution maximale	Resolución máxima	Risoluzione massima	5120 x 1440
Image Quality	Bildqualität	Qualité de l'image	Calidad de imagen	Qualità dell'immagine	DQHD
Panel Type	Panel-Typ	Type de panneau	Tipo de panel	Tipo di pannello	VA
Input	Eingabe	Entrée	Entrada	Ingresso	USB-C, USB 2.0 HUB (2 x USB-A, USB-B), DisplayPort 1.4, HDMI 2.0, 3.5mm Audio, RJ45
Brightness	Helligkeit	Luminosité	Brillo	Luminosità	320 cd/m ² (HDR off) 400 cd/m ² (HDR on)
Gamut	Gamut	Gamme	Gamut	Gamut	sRGB 99%, DCI-P3 95%, ΔE<2
Refresh Rate	Bildwiederholrate	Taux de rafraîchissement	Frecuencia de actualización	Frequenza di aggiornamento	120Hz
Response Time	Reaktionszeit	Temps de réponse	Tiempo de respuesta	Tempo di risposta	5ms (OD)
Power Input	Leistungsaufnahme	Puissance d'entrée	Potencia de entrada	Potenza in ingresso	AC 100-240V (50/60Hz)
Aspect Ratio	Bildseitenverhältnis	Rapport d'aspect	Relación de aspecto	Rapporto d'aspetto	32:9
Contrast Ratio	Kontrastverhältnis	Rapport de contraste	Relación de contraste	Rapporto di contrasto	3000:1
Viewing Angle	Betrachtungswinkel	Angle de vision	Ángulo de visión	Angolo di visione	178°(H)/178°(V)
Screen Coating	Bildschirm-Beschichtung	Revêtement de l'écran	Revestimiento de la pantalla	Rivestimento dello schermo	Matte
Low Blue Light	Niedriges blaues Licht	Faible lumière bleue	Luz azul baja	Luce blu bassa	Yes
PIP & PBP	PIP & PBP	PIP & PBP	PIP & PBP	PIP & PBP	Yes
Adaptive Sync	Adaptive Sync	Synchronisation adaptative	Sincronización adaptativa	Sincronizzazione adattiva	Yes
VESA Mount	VESA-Halterung	Montage VESA	Montaje VESA	Montaggio VESA	75 x 75
Stand Dimension	Abmessungen des Standfußes	Dimension du support	Dimensiones del soporte	Dimensioni del supporto	535.5x437.8x286.8mm
Stand Height Adjustment Range	Höhenverstellbereich des Ständers	Plage de réglage de la hauteur du support	Rango de ajuste de la altura del soporte	Gamma di regolazione dell'altezza dello stativo	95mm
Speaker	Lautsprecher	Haut-parleur	Altavoz	Altoparlante	2 x 3W
Pixel Pitch (H/V)	Pixelabstand (H/V)	Pas de pixel (H/V)	Paso de píxeles (H/V)	Passo dei pixel (H/V)	0.11919 x 0.11919 mm
MTBF	MTBF	MTBF	MTBF	MTBF	10,000 Hrs
Warranty	Garantie	Garantie	Garantía	Garanzia	3 Years
Compliance	Konformität	Conformité	Conformidad	Conformità	CE, FCC, UKCA, ICES, RoHS, WEE
Country of Origin	Herkunftsland	Pays d'origine	País de origen	Paese di origine	China
Package Includes	Paket enthält	Le paquet comprend	El paquete incluye	La confezione include	49" Monitor, HDMI, DP, USB-C, USB-B to A Cables, Power Cable, Height Adjustable Stand

Care & Safety | Soins et sécurité | Cuidado y seguridad | Pflege und Sicherheit | Cura e sicurezza

- Avoid exposing your monitor directly to sunlight or other heat source. Place your monitor away from the sun to reduce glare.
 - Put your monitor in a well ventilated, clean, dry area.
 - Do not place any heavy things on top of your monitor.
 - Keep your monitor away from magnets, motors, transformers, speakers, and TV sets.
 - If smoke, abnormal noise or odor came out from your monitor, caution you should remove the power cord immediately and call your service center.
 - Never remove the rear cover of your monitor cabinet. The display unit inside contains high-voltage parts and may cause electric shock
 - Never try to repair your monitor yourself. Always call your service center or a qualified technician.
-
- Évitez d'exposer votre moniteur directement à la lumière du soleil ou à une autre source de chaleur. Placez votre moniteur à l'abri du soleil pour réduire les reflets.
 - Placez votre moniteur dans un endroit bien ventilé, propre et sec.
 - Ne placez pas d'objets lourds sur votre moniteur.
 - Éloignez votre moniteur des aimants, des moteurs, des transformateurs, des haut-parleurs et des téléviseurs.
 - Si de la fumée, des bruits ou des odeurs anormales s'échappent de votre moniteur, débranchez immédiatement le cordon d'alimentation et appelez votre centre de service.
 - Ne retirez jamais le couvercle arrière du boîtier de votre moniteur. L'unité d'affichage à l'intérieur contient des pièces à haute tension et peut provoquer un choc électrique.
 - N'essayez jamais de réparer votre moniteur vous-même. Appelez toujours votre centre de service ou un technicien qualifié.
-
- Evite exponer el monitor directamente a la luz solar o a cualquier otra fuente de calor. Coloque el monitor alejado del sol para reducir el deslumbramiento.
 - Coloque el monitor en un lugar bien ventilado, limpio y seco.
 - No coloque objetos pesados encima del monitor.
 - Mantenga el monitor alejado de imanes, motores, transformadores, altavoces y televisores.
 - Si el monitor desprende humo, ruidos u olores anormales, desconecte inmediatamente el cable de alimentación y llame al servicio técnico.
 - No retire nunca la cubierta posterior de la carcasa del monitor. La unidad de visualización que se encuentra en el interior contiene piezas de alta tensión y puede provocar una descarga eléctrica.
 - Nunca intente reparar el monitor usted mismo. Llame siempre a su centro de servicio o a un técnico cualificado.
-
- Vermeiden Sie es, den Monitor direkt dem Sonnenlicht oder anderen Wärmequellen auszusetzen. Stellen Sie den Monitor nicht in die Sonne, um Blendeffekte zu vermeiden.
 - Stellen Sie den Monitor an einem gut belüfteten, sauberen und trockenen Ort auf.
 - Stellen Sie keine schweren Gegenstände auf den Monitor.
 - Halten Sie Ihren Monitor von Magneten, Motoren, Transformatoren, Lautsprechern und Fernsehgeräten fern.
 - Wenn Rauch, abnormale Geräusche oder Gerüche aus dem Monitor austreten, sollten Sie sofort das Netzkabel abziehen und den Kundendienst verständigen.
 - Entfernen Sie niemals die hintere Abdeckung des Monitorgehäuses. Die Anzeigeeinheit im Inneren enthält Hochspannungsteile und kann einen Stromschlag verursachen.
 - Versuchen Sie niemals, Ihren Monitor selbst zu reparieren. Wenden Sie sich immer an Ihr Kundendienstzentrum oder einen qualifizierten Techniker.
-
- Evitare di esporre il monitor direttamente alla luce del sole o ad altre fonti di calore. Posizionare il monitor lontano dal sole per ridurre i riflessi.
 - Collocare il monitor in un'area ben ventilata, pulita e asciutta.
 - Non collocare oggetti pesanti sopra il monitor.
 - Tenere il monitor lontano da magneti, motori, trasformatori, altoparlanti e televisori.
 - Se dal monitor fuoriescono fumo, rumori o odori anomali, è necessario rimuovere immediatamente il cavo di alimentazione e chiamare il centro di assistenza.
 - Non rimuovere mai il coperchio posteriore del monitor. L'unità di visualizzazione all'interno contiene parti ad alta tensione e può causare scosse elettriche.
 - Non cercare mai di riparare il monitor da soli. Rivolgersi sempre al centro di assistenza o a un tecnico qualificato.

Safety Precautions

This monitor is manufactured and tested on a ground principle that a user's safety comes first. However, improper use or installation may result danger to the monitor as well as to the user. Carefully go over the following WARNINGS before installation and keep this guide handy.

WARNINGS

- This monitor should be operated only at the correct power sources indicated on the label on the rear end of the monitor. If you're unsure of the power supply in your residence, consult your local dealer or power company.
- Do not try to repair the monitor yourself as it contains no user-serviceable parts. The monitor should only be repaired by a qualified technician.
- Do not remove the monitor cabinet. There is high-voltage parts inside that may cause electric shock to human bodies, even when the power cord is disconnected.
- Stop using the monitor if the cabinet is damaged. Have it checked by a service technician.
- Put your monitor only in a clean, dry environment. Unplug the monitor immediately if gets wet and consult your service technician.
- Always unplug the monitor before cleaning it. Clean the cabinet with a clean, dry cloth. Apply non-ammonia based cleaner onto the cloth, not directly onto the glass screen.
- Keep the monitor away from magnetic objects, motors, TV sets, and transformer.
- Do not place heavy objects on the cable or power cord.
- Due to safety concerns, if the VESA mounting kit is purchased separately, please make sure the mounting kit is UL-Listed, and replaceable only by service personnel.

FCC RADIO FREQUENCY INTERFERENCE STATEMENT WARNING: (FOR FCC CERTIFIED MODELS)

This monitor has been tested and found compliant with the limits for a Class B digital device, pursuant to part 15 of the FCC Rules. These limits are designed to provide proper protection against harmful interference to a residential installation. This monitor generates, uses, and can radiate radio frequency energy. Harmful interference to radio communication may be led as a result if it's not properly installed and used. However, there is no guarantee that interference will not occur in a particular installation. If this monitor does cause serious interference to radio or television reception, resetting the monitor may determine it. Moreover, users are encouraged to correct interference by doing one or more of the following:



- Reorient or relocate the receiving antenna.
- Move the monitor and the receiver further away from each other.
- Connect the monitor into an outlet on a circuit different from that to which the receiver is connected.
- Consult your local dealer or an qualified technician.

FCC Warning:

To assure a continued FCC compliance, a user must use a grounded power supply cord and the provided shielded video interface cable with bonded ferrite cores. Also, any unauthorized changes or modifications to this monitor would void the user's authority to operate this device.

Each country in the European Union should have its collection centers for electrical and electronic equipment recycling. For information about your recycling drop off area, please contact your related electrical and electronic equipment waste management authority or the retailer where you bought the product.

Note: If necessary, shielded interface cables and AC power cord must be used to meet the emission level limits.



According to WEEE regulation, this monitor can't be handled as normal trash in Europe when it is out of usage. Please refer to the recycle information from our website to handle it.

CAN ICES-3(B)/NMB-3(B)

This device complies with Part 15 of the FCC Rules.

Operation is subject to the following two conditions:

- (1) this device may not cause harmful interference, and
- (2) this device must accept any interference received, including interference that may cause undesired operation.



The terms HDMI and HDMI High-Definition Multimedia Interface, and the HDMI Logo are trademarks or registered trademarks of HDMI Licensing Administrator, Inc. in the United States and other countries.