

INSTALLATION INSTRUCTIONS

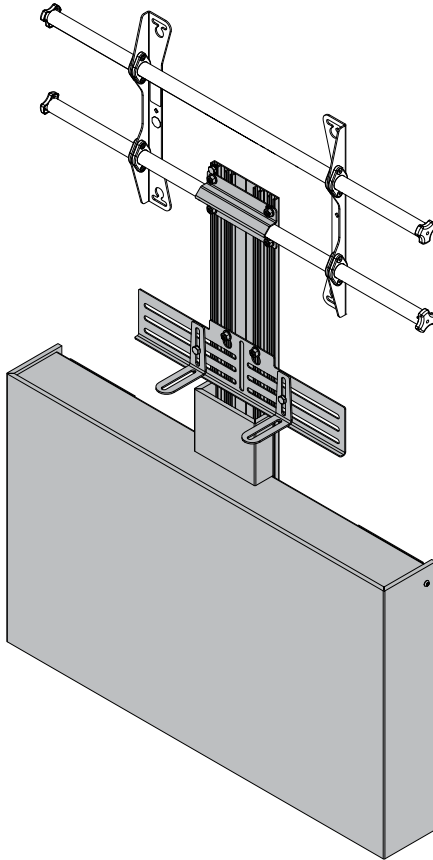

Fusion Storage Cabinet

CHIEF[®]

A brand of **legrand**[®]

FCASTC

DISCLAIMER

Legrand | AV and its affiliated corporations and subsidiaries (collectively “Legrand | AV”), intend to make this manual accurate and complete. However, Legrand | AV makes no claim that the information contained herein covers all details, conditions or variations, nor does it provide for every possible contingency in connection with the installation or use of this product. The information contained in this document is subject to change without notice or obligation of any kind. Legrand | AV makes no representation of warranty, expressed or implied, regarding the information contained herein. Legrand | AV assumes no responsibility for accuracy, completeness or sufficiency of the information contained in this document.

Chief® is a registered trademark of Legrand AV Inc.

DEFINITIONS

MOUNTING SYSTEM: A MOUNTING SYSTEM is the primary Chief product to which an accessory and/or component is attached.

ACCESSORY: AN ACCESSORY is the secondary Chief product which is attached to a primary Chief product, and may have a component attached or setting on it.

COMPONENT: A COMPONENT is an audiovisual item designed to be attached or resting on an accessory or mounting system such as a video camera, CPU, screen, display, projector, etc.

 **WARNING:** A WARNING alerts you to the possibility of serious injury or death if you do not follow the instructions.

 **CAUTION:** A CAUTION alerts you to the possibility of damage or destruction of equipment if you do not follow the corresponding instructions.

 **IMPORTANT SAFETY INSTRUCTIONS**

 **WARNING:** Failure to read, thoroughly understand, and follow all instructions can result in serious personal injury, damage to equipment, or voiding of factory warranty! It is the installer’s responsibility to make sure all accessories are properly assembled and installed using the instructions provided.

 **WARNING:** Failure to provide adequate structural strength for this accessory can result in serious personal injury or damage to equipment! It is the installer’s responsibility to make sure the structure to which this accessory is attached can support five times the combined weight of all equipment. Reinforce the structure as required before installing the accessory.

 **WARNING:** Exceeding the weight capacity can result in serious personal injury or damage to equipment! It is the installer’s responsibility to make sure the combined weight of all components attached to this accessory does not exceed 60 lbs (27.2 kg).

- Camera shelf: 15 lbs (6.8 kg)
- Storage panel: 20 lbs (9.1 kg)
- Rack brackets: 10 lbs (4.5 kg)

 **WARNING:** Use this accessory only for its intended use as described in these instructions. Do not use attachments not recommended by the manufacturer.

 **WARNING:** Never operate this accessory if it is damaged. Return the accessory to a service center for examination and repair.

 **WARNING:** Do not use this accessory outdoors.

 **WARNING:** RISK OF INJURY TO PERSONS! Do not use this accessory to support video equipment such as televisions or computer monitors.







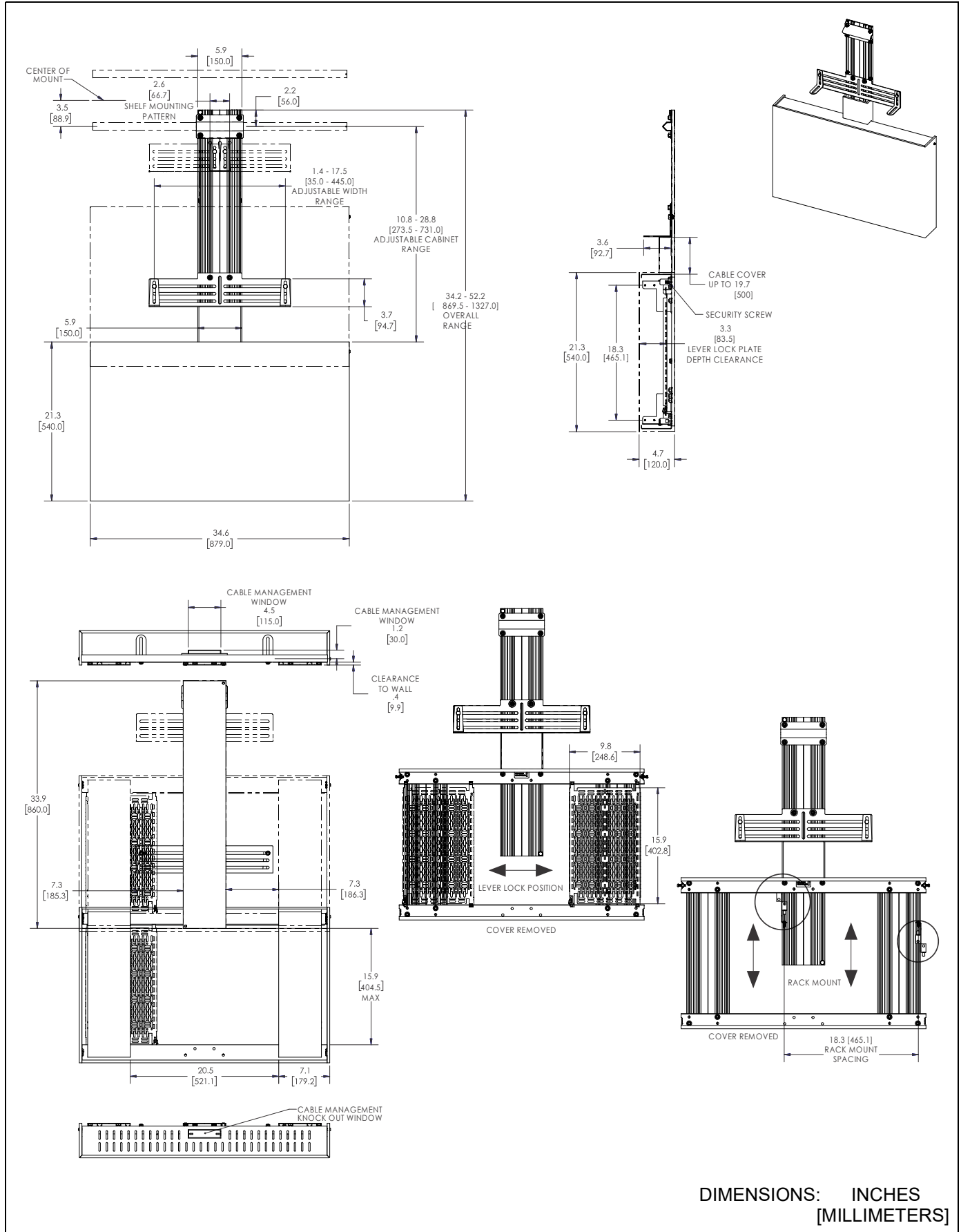

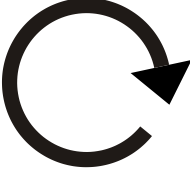

IMPORTANT ! : The FCASTC accessory can be mounted directly to a bare 8" concrete or 8"x8"16" concrete block wall.

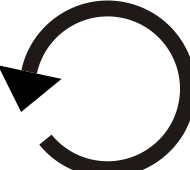
--SAVE THESE INSTRUCTIONS--

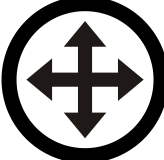
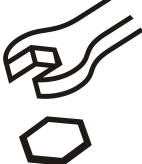
DIMENSIONS



LEGEND

	<p>Tighten Fastener</p> <p>Apretar elemento de fijación</p> <p>Befestigungsteil festziehen</p> <p>Apertar fixador</p> <p>Serrare il fissaggio</p> <p>Bevestiging vastdraaien</p> <p>Serrez les fixations</p>		<p>Pencil Mark</p> <p>Marcar con lápiz</p> <p>Stiftmarkierung</p> <p>Marcar com lápis</p> <p>Segno a matita</p> <p>Potloodmerkteken</p> <p>Marquage au crayon</p>
	<p>Loosen Fastener</p> <p>Aflojar elemento de fijación</p> <p>Befestigungsteil lösen</p> <p>Desapertar fixador</p> <p>Allentare il fissaggio</p> <p>Bevestiging losdraaien</p> <p>Desserrez les fixations</p>		<p>Drill Hole</p> <p>Perforar</p> <p>Bohrloch</p> <p>Fazer furo</p> <p>Praticare un foro</p> <p>Gat boren</p> <p>Percez un trou</p>
	<p>Phillips Screwdriver</p> <p>Destornillador Phillips</p> <p>Kreuzschlitzschraubendreher</p> <p>Chave de fendas Phillips</p> <p>Cacciavite a stella</p> <p>Kruiskopschroevendraaier</p> <p>Tournevis à pointe cruciforme</p>		<p>Adjust</p> <p>Ajustar</p> <p>Einstellen</p> <p>Ajustar</p> <p>Regolare</p> <p>Afstellen</p> <p>Ajuster</p>
	<p>Open-Ended Wrench</p> <p>Llave de boca</p> <p>Gabelschlüssel</p> <p>Chave de bocas</p> <p>Chiave a punte aperte</p> <p>Steeksleutel</p> <p>Clé à fourche</p>		<p>Remove</p> <p>Quitar</p> <p>Entfernen</p> <p>Remover</p> <p>Rimuovere</p> <p>Verwijderen</p> <p>Retirez</p>
	<p>By Hand</p> <p>A mano</p> <p>Von Hand</p> <p>Com a mão</p> <p>A mano</p> <p>Met de hand</p> <p>À la main</p>		<p>Optional</p> <p>Opcional</p> <p>Optional</p> <p>Opcional</p> <p>Opzionale</p> <p>Optie</p> <p>En option</p>
	<p>Hex-Head Wrench</p> <p>Llave de cabeza hexagonal</p> <p>Sechskantschlüssel</p> <p>Chave de cabeça sextavada</p> <p>Chiave esagonale</p> <p>Zeskantsleutel</p> <p>Clé à tête hexagonale</p>		<p>Security Wrench</p> <p>Llave de seguridad</p> <p>Sicherheitsschlüssel</p> <p>Chave de segurança</p> <p>Chiave di sicurezza</p> <p>Veiligheidssleutel</p> <p>Clé de sécurité</p>

TOOLS REQUIRED FOR INSTALLATION

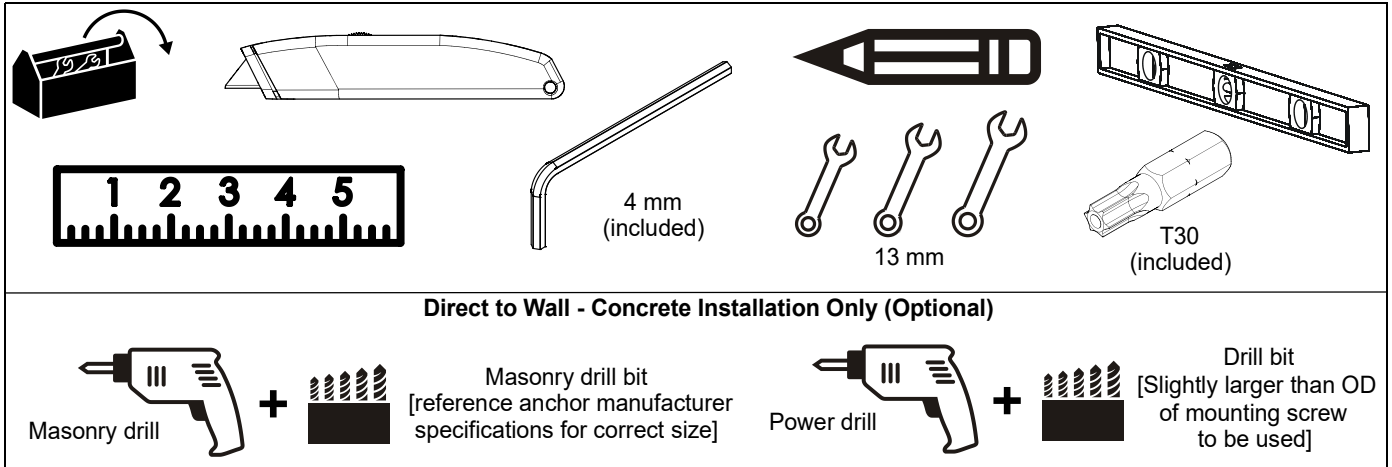

PARTS

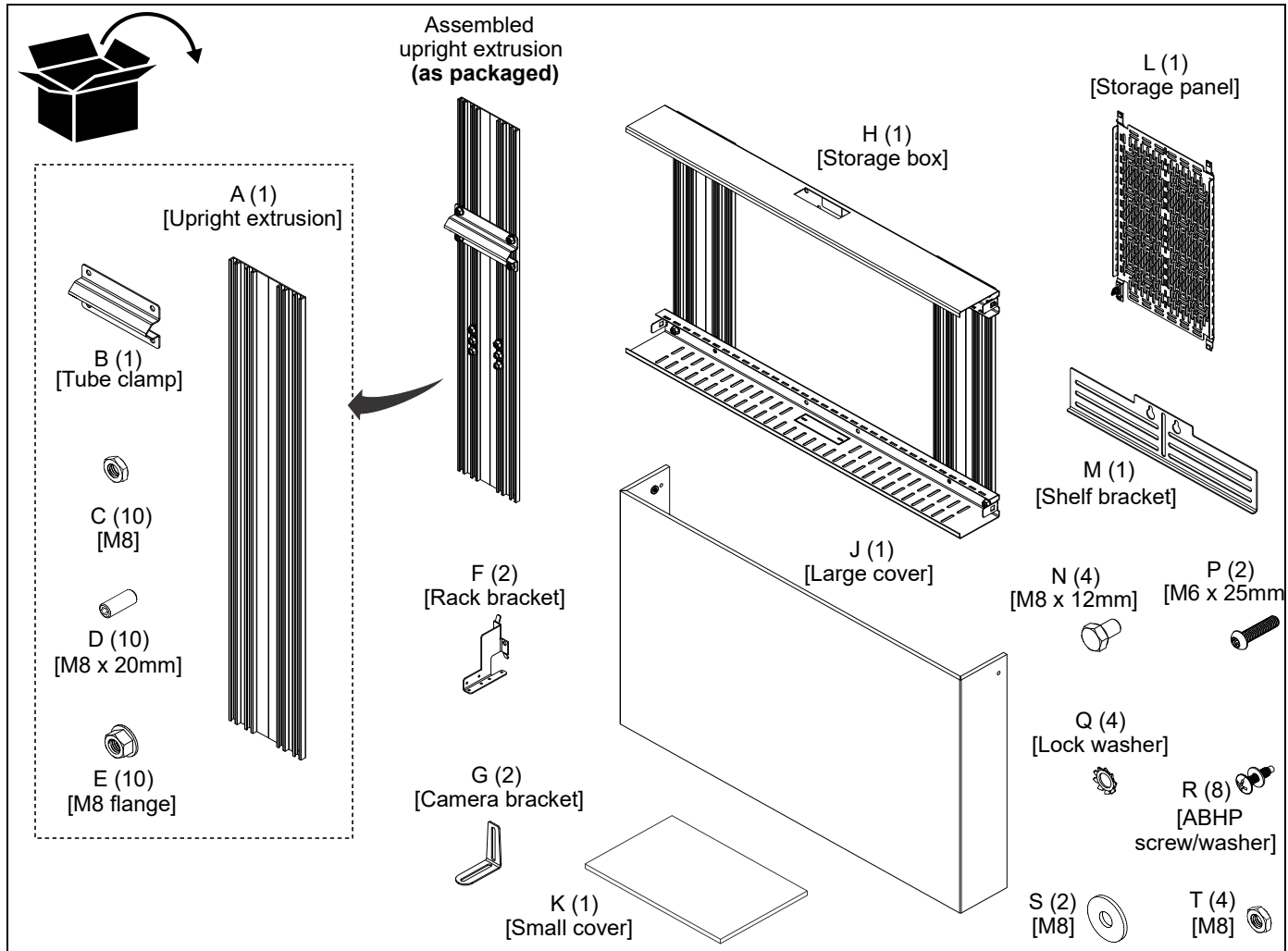

Optional Recommended Concrete Mounting Hardware (not included)

AA (4)
Concrete wall anchor
[8mm (UX8) or 10mm (UX10) recommended]

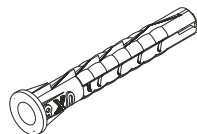

AB (4)
Mounting screw
[Compatible with selected anchors]

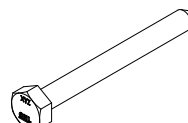

Assembly And Installation

Upright Extrusion Installation

1. Before installation, remove the tube clamp (B), ten M8 nuts (C), ten M8 x 20mm screws (D), and ten M8 flange nuts (E) from the upright extrusion (A) and set aside. (See Figure 1)

NOTE: The M8 nuts (C) and M8 x 20mm screws (D) can be left installed to each other.

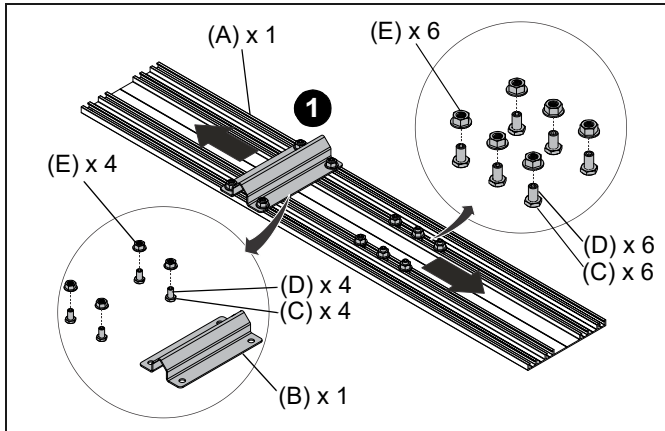

Figure 1

Installation - To Wall Mount

1. Slide the upright extrusion (A) behind the lower horizontal bar on the display mount. (See Figure 2)

IMPORTANT ! : Position the safety hole in the top of the upright extrusion (A) on the left side.

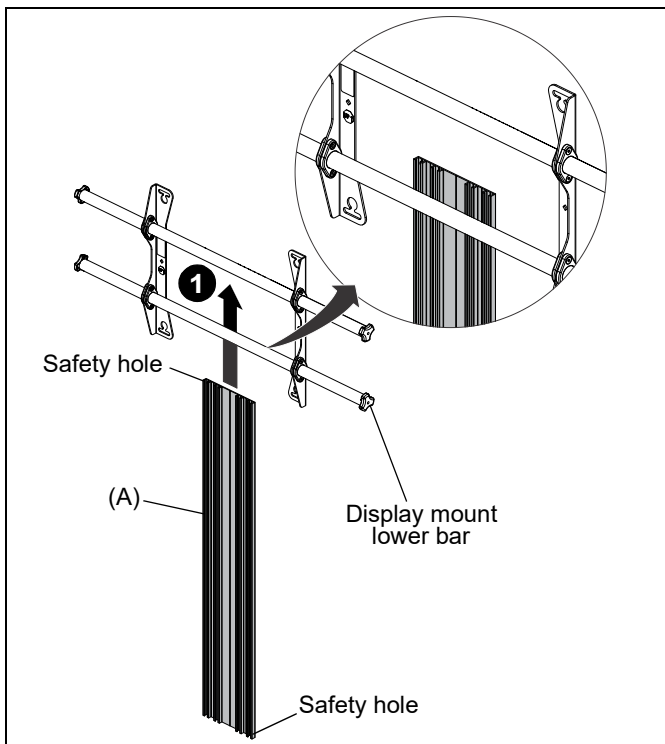

Figure 2

2. Slide two assembled M8 x 20mm screws (C) and M8 nuts (D) down into the outside channels of the upright extrusion (A) until they are positioned above the lower bar of the display mount. Tighten one of the screws (C) to hold the upright extrusion in place on the mount bar.
3. Place the tube clamp (B) over the lower bar of the display mount and the ends of the M8 x 20mm screws (C). (See Figure 3)

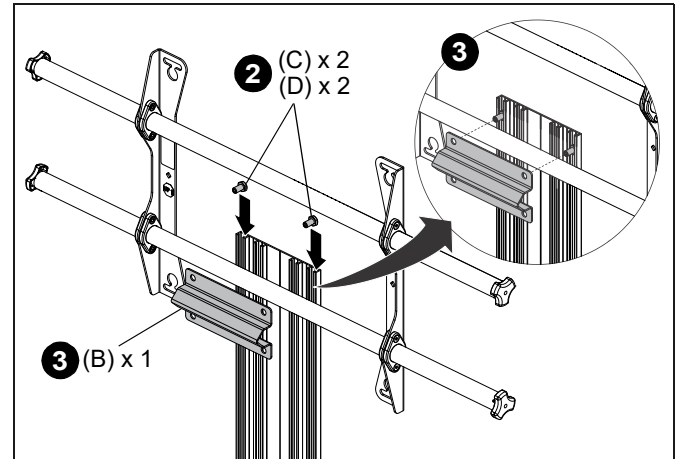

Figure 3

4. Adjust the position of the upright extrusion until it is level, then tighten the second M8 x 20mm screw (C) left loose in Step 3.

IMPORTANT ! : Make sure the upright extrusion is level before moving on to the next step.

5. Loosely install two M8 flange nuts (E) to the ends of the M8 x 20mm screws (D). (See Figure 4)

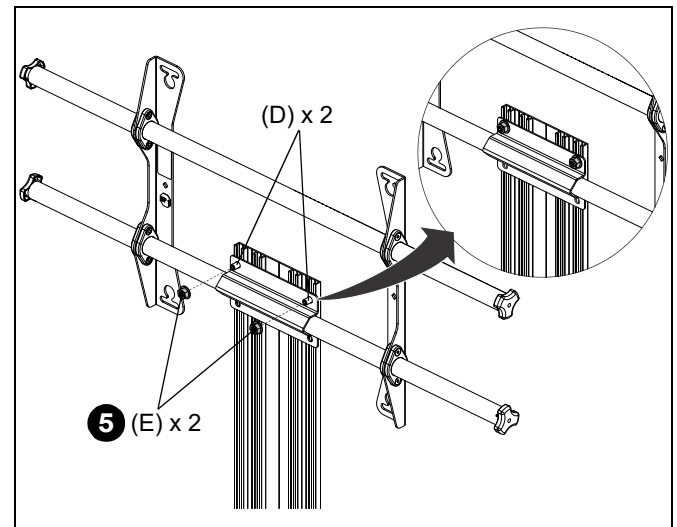

Figure 4

6. Slide two assembled M8 x 20mm screws (C) and M8 nuts (D) up into the outside channels from the bottom of the upright extrusion (A) until they are positioned through the bottom holes in the bar clamp. Tighten the screws to hold them in position. (See Figure 5)

Storage Box Installation

1. Slide two assembled M8 x 20mm screws (C) and M8 nuts (D) up into the outside channels of the upright extrusion (A) until they are in the desired position of the top edge of the storage box (H). Tighten the screws (C) to hold them in the desired position. (See Figure 7)

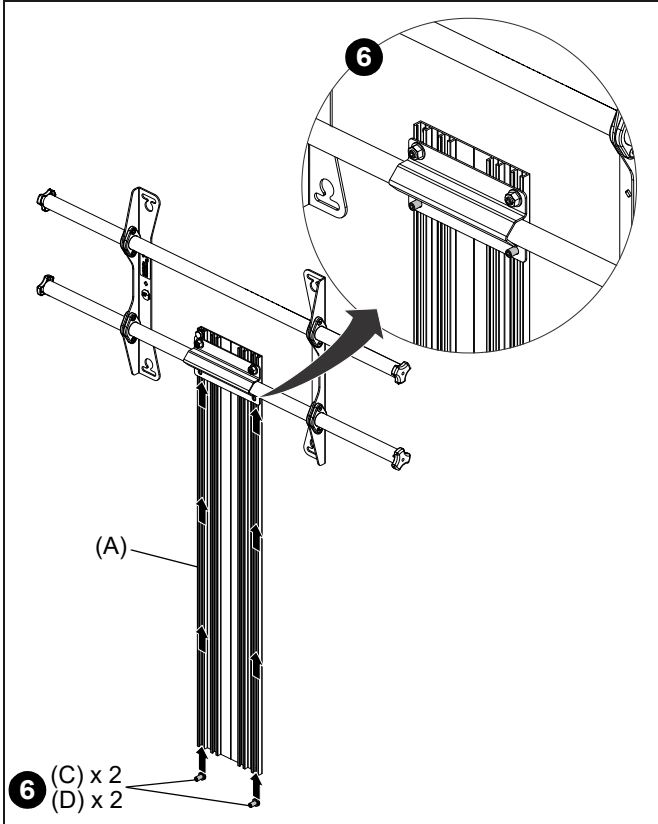

Figure 5

7. Tighten the two M8 x 20mm screws (D), then loosely install two M8 flange nuts (E) to the screws (D).
8. Tighten all four M8 flange nuts (E) securing the bar clamp to the M8 x 20mm screws (D) screws. (See Figure 6)

IMPORTANT ! : Make sure the upright extrusion is level before tightening the nuts.

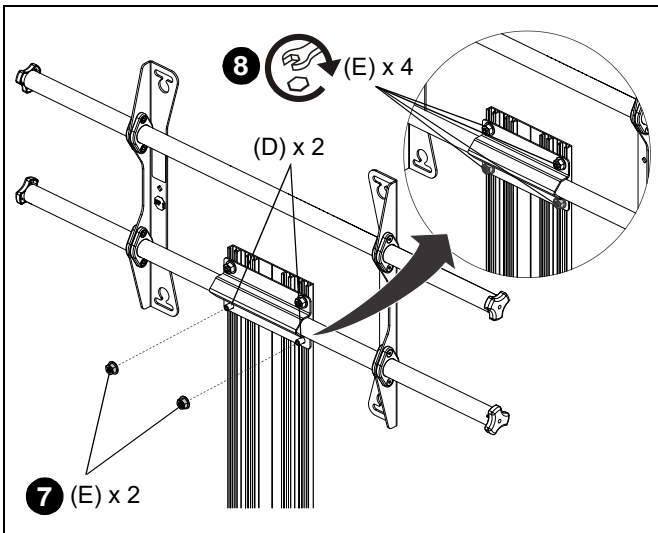

Figure 6

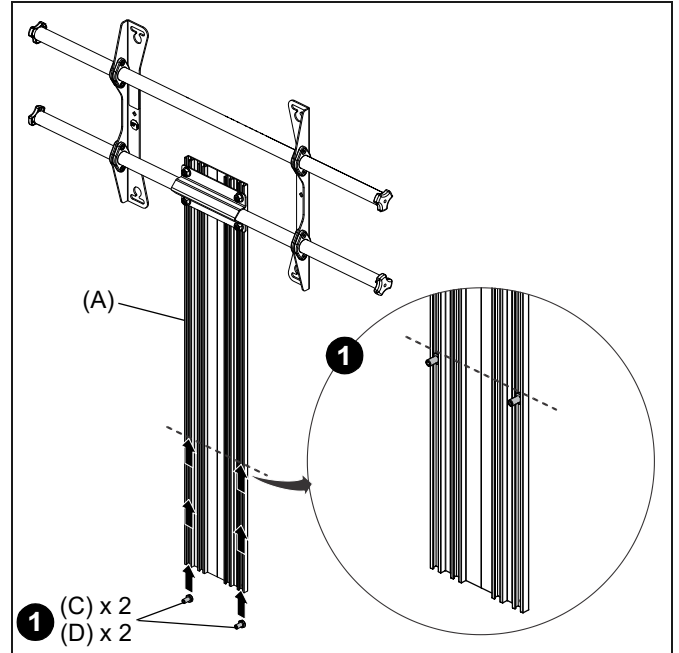

Figure 7

2. Hang the storage box (H) on the two M8 x 20mm screws (D) in the upright extrusion (A). Loosen one of the screws (D) and adjust the position of the storage box (H) until it is level. (See Figure 8)

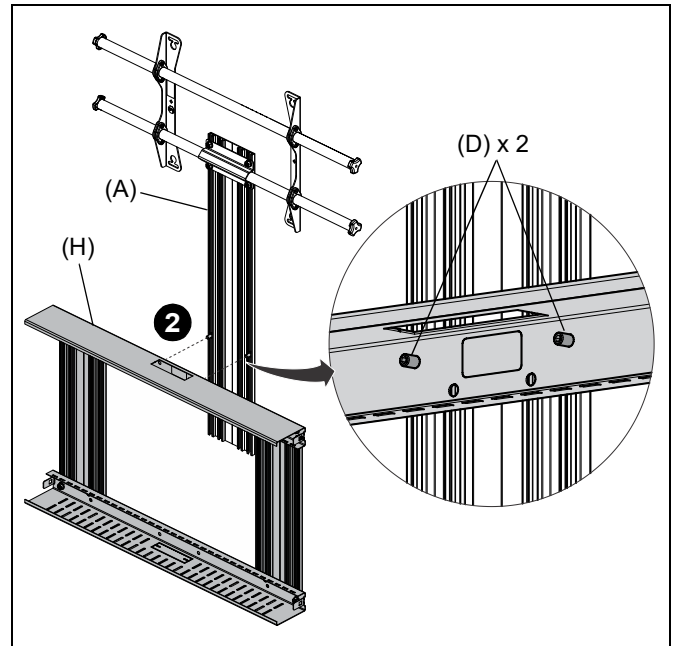

Figure 8

3. Re-tighten the loose M8 x 20mm screw (D), then secure the storage box (H) to the upright extrusion (A) using two M8 flange nuts (E). (See Figure 9)

IMPORTANT ! : Make sure the storage box is level before tightening the nuts.

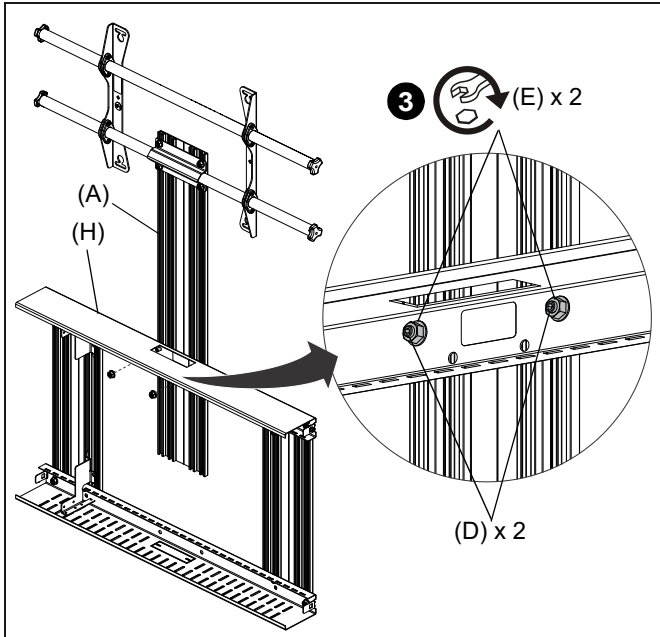

Figure 9

4. Slide two M8 nuts (T) into the outside channels and position them over both safety holes in the upright extrusion (A).
5. Install two M8 x 12mm screws (N) and lock washers (Q) through the M8 nuts (T) and into the safety holes in the upper and lower corners of the upright extrusion (A). (See Figure 10)

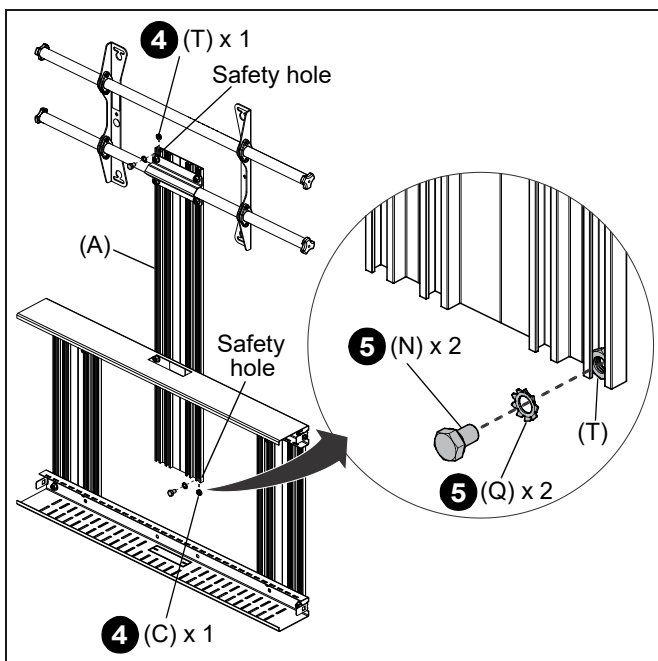

Figure 10

Installation - Direct to Wall (Optional)

IMPORTANT ! : The FCASTC accessory can be mounted directly to a bare 8" concrete or 8"x8"x16" concrete block wall only. The hardware required for direct concrete wall installation is not included with FCASTC.

1. Slide two assembled M8 x 20mm screws (C) and M8 nuts (D) down into the outside channels of the upright extrusion (A) from the top end. (See Figure 11)
2. Slide two assembled M8 x 20mm screws (C) and M8 nuts (D) up into the outside channels of the upright extrusion (A) from the bottom end. (See Figure 11)

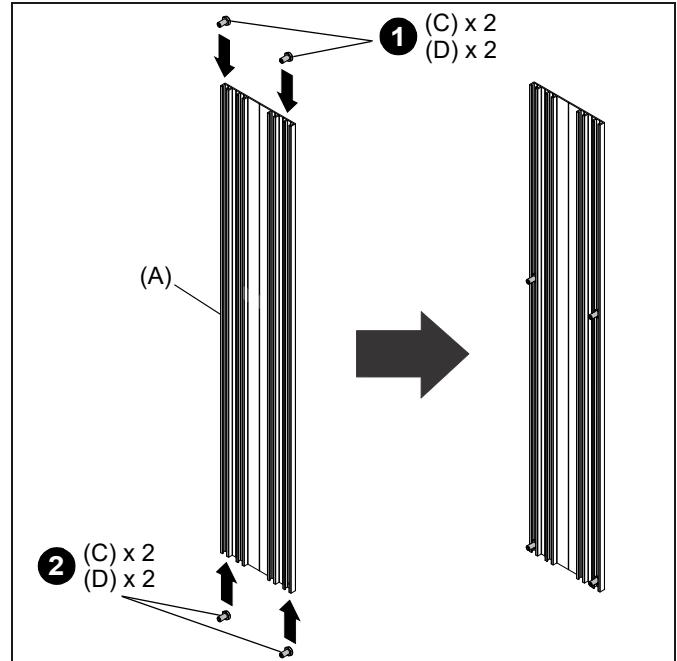

Figure 11

3. Assemble the storage box (H) on the four M8 x 20mm screws (D) in the upright extrusion (A). Adjust the position of the storage box (H) until it is level with the bottom edge of the extrusion (A). (See Figure 12)

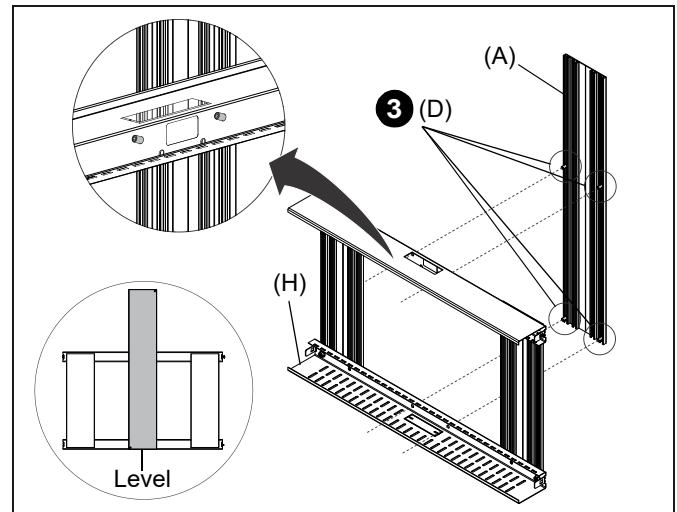

Figure 12

- Lay the assembled storage box (H) down on a smooth level surface. Mark and drill two mounting holes through the v-notch in each side extrusion (four total pilot holes). Pilot holes must be located within 32-100mm from the top/bottom of the extrusions. (See Figure 13)

IMPORTANT ! : Elevate the storage box (H) to prevent drilling into the surface located below.

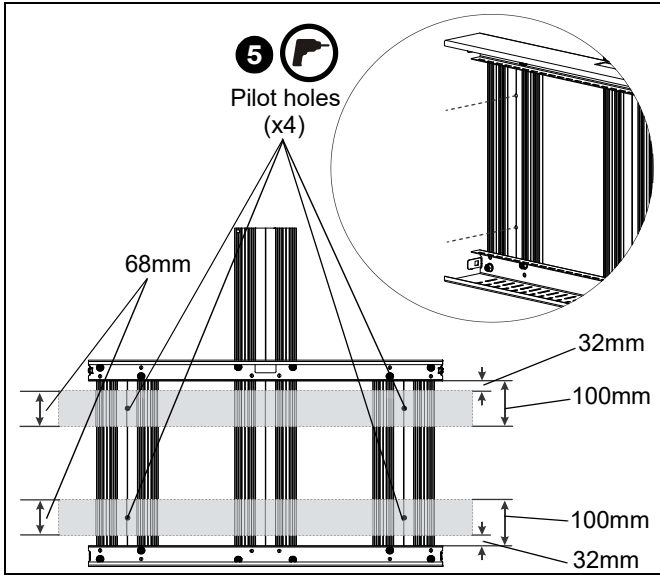

Figure 13

- Position the storage box (H) against the wall in the desired mounting position. Use a level to ensure of an even mount.
- Mark the positions of the four mounting holes in the storage box extrusions on the wall. (See Figure 14)
- Remove the storage box from the wall and drill a pilot hole at each marked location. (See Figure 14)
- Use a hammer to install four concrete anchors (AA) into drilled pilot holes. (See Figure 15)

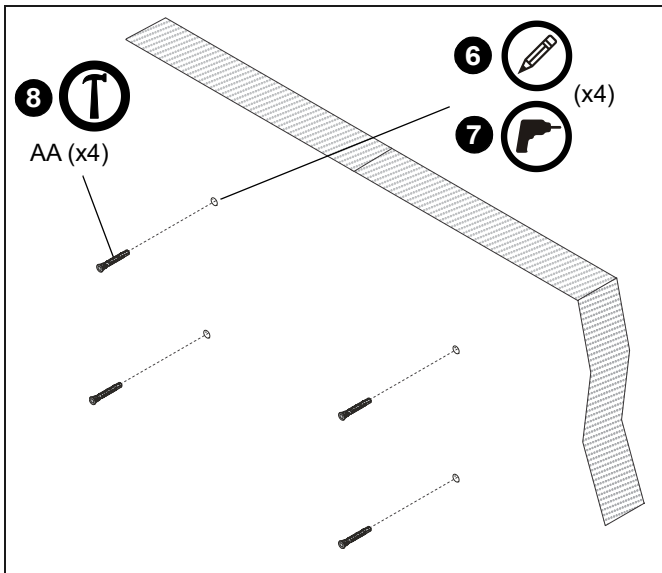

Figure 14

- Replace the storage box (H) on the wall and position the holes in the extrusions over the anchors in the wall. Install using four lag screws (AB). (See Figure 15)

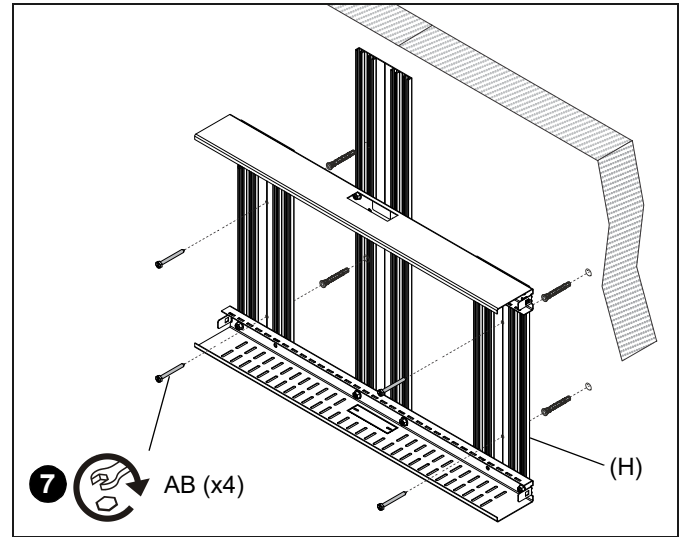

Figure 15

IMPORTANT ! : Concrete mounting hardware is not included. Drill pilot holes of appropriate size depending on the diameter of the mounting hardware to be used.

Configuring Storage Box

Installing Storage Panel



WARNING: Exceeding the weight capacity can result in serious personal injury or damage to equipment! It is the installer's responsibility to make sure the weight of components attached to the storage panel does not exceed 20 lbs (9.1 kg)

- Slide the panel end without latches up into the desired slots on one side of the rear frame opening.
- Pivot panel in and slide it down toward the slots on lower side of the rear frame panel opening. The panel will snap into the slots, securing it to the rear frame. (See Figure 16)
- To remove the panel, squeeze the spring-loaded latch on lower end tabs of the storage panel (L) and slide the panel up and out of the slots on the rear frame.

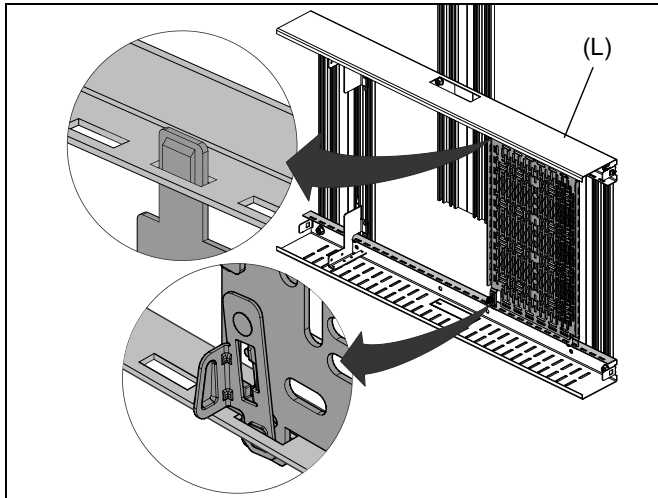

Figure 16

NOTE: Up to three storage panels (L) can be used simultaneously (only one included). (See Figure 17)

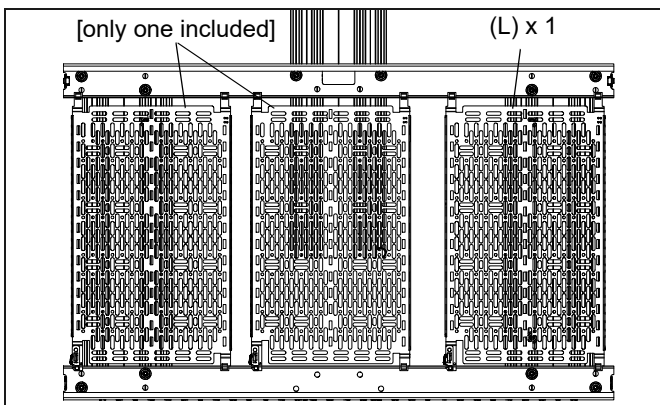

Figure 17

Installing Rack Brackets

⚠ WARNING: Exceeding the weight capacity can result in serious personal injury or damage to equipment! It is the installer's responsibility to make sure the weight of components attached to the rack brackets does not exceed 10 lbs (4.5 kg)

IMPORTANT ! : The storage box (H) has eight pre-installed M8 x 12mm bolts (N) and M8 flange nuts (H) to be used for installing the rack brackets (F).

1. Remove two M8 flange nuts (E) from two M8 x 12mm bolts (N) inside the storage box (H). Hold the bolts in the desired mounting locations of the rack brackets (F).
2. Position two rack brackets (F) over the M8 x 12mm bolts (N) in the desired locations and secure using two M8 flange nuts (E). (See Figure 18)

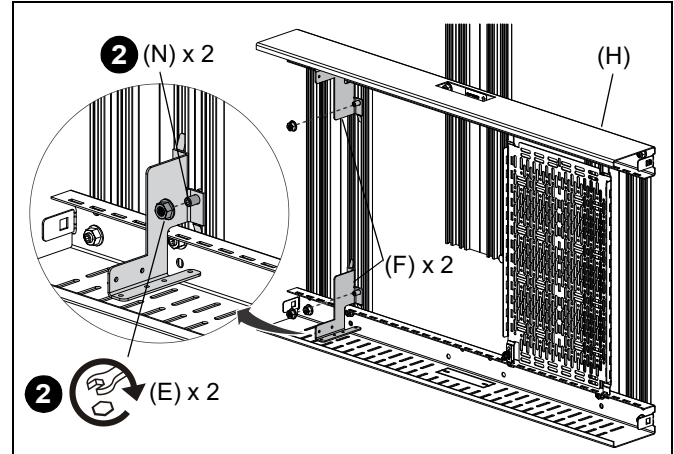

Figure 18

Routing Cables

1. Route cables up through the recess at the top of the storage box (H). (See Figure 19)

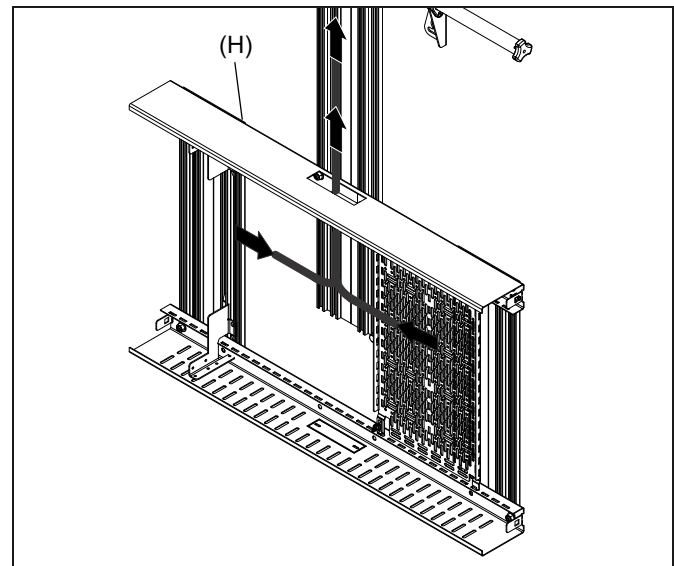

Figure 19

Finishing Installation

1. Attach the large cover (J) to the outside of the storage box (H). (See Figure 20)

NOTE: The bottom rail on the cover will hook into the bottom edge of the storage box.

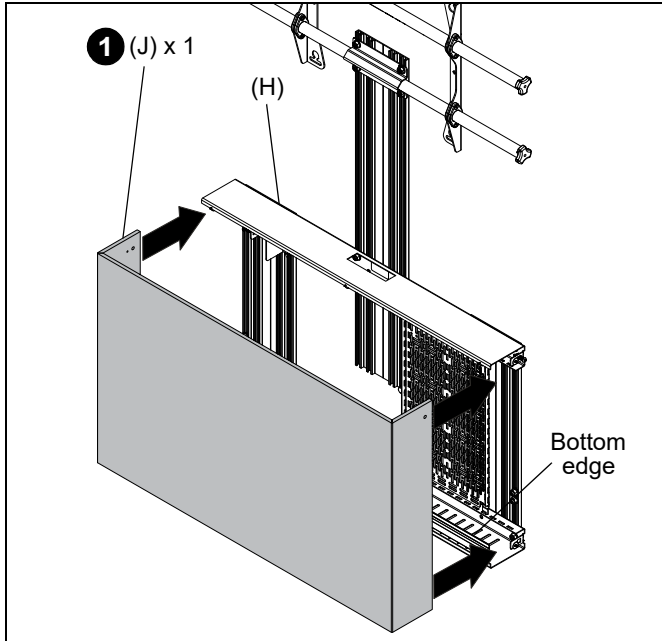

Figure 20

Installing Camera Shelf



WARNING: Exceeding the weight capacity can result in serious personal injury or damage to equipment! It is the installer's responsibility to make sure the weight of components attached to the camera shelf does not exceed 15 lbs (6.8 kg)

1. Install two camera brackets (G) to the slots in the shelf bracket (M) in the desired locations using two M8 x 12mm screws (N), lock washers (Q), and M8 nuts (T). (See Figure 21)

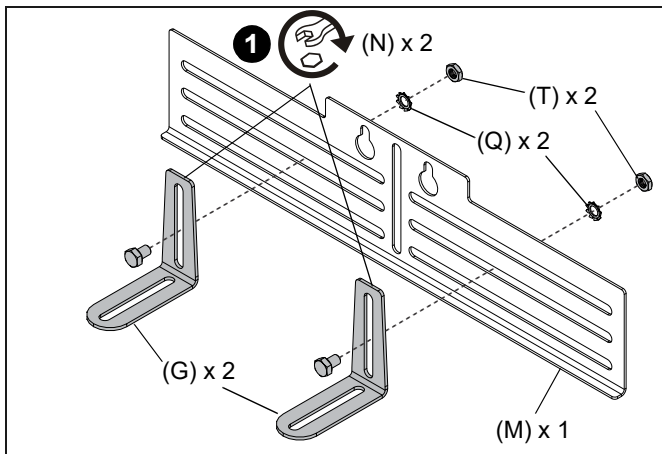

Figure 21

2. Install the camera to the camera brackets (G) using the hardware included with the camera. (See Figure 22)

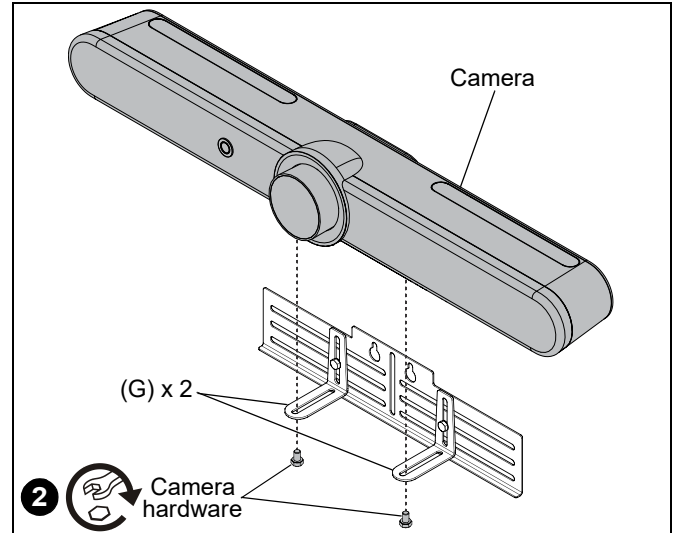

Figure 22

IMPORTANT ! : If the camera to be installed mounts to the back of the unit, install directly to the shelf bracket (M) using the hardware included with the camera.

3. Determine the location of the bottom edge of the display.
4. Slide two M8 nuts (C) into the inside channels shown and hold them in place below the bottom edge of the display.
5. Install two M8 x 12mm screws (D) through the M8 nuts (C). Tighten the screws to hold the nuts in place (See Figure 23)

NOTE: M8 nuts (C) must be held in place in the desired location while installing the other hardware.

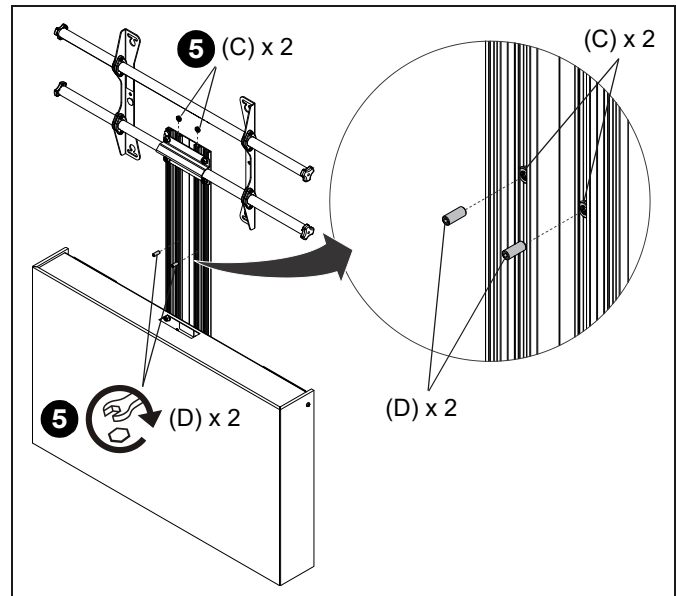

Figure 23

6. Hang the assembled shelf bracket (M) onto the M8 x 12mm screws (N) in the upright extrusion (A). (See Figure 24)
7. Secure the camera using two M8 washers (S) and two M8 flange nuts (E). (See Figure 24)

IMPORTANT ! : Make sure the camera is level before tightening the nuts.

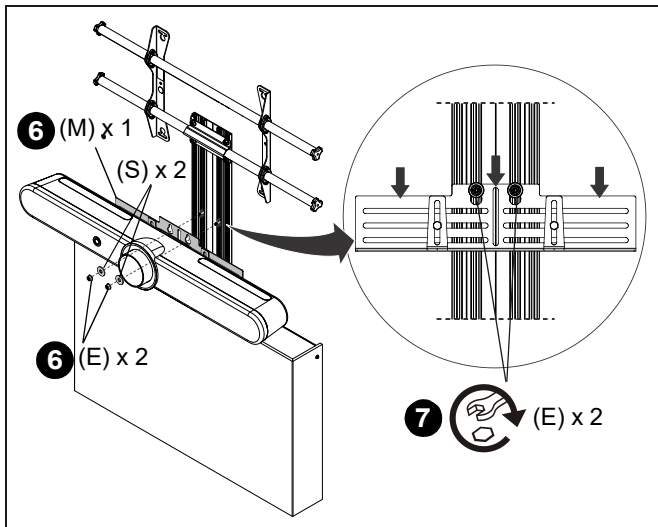

Figure 24

8. Measure the distance between the top edge of the storage box (H) and the lower edge of the camera. (See Figure 25)

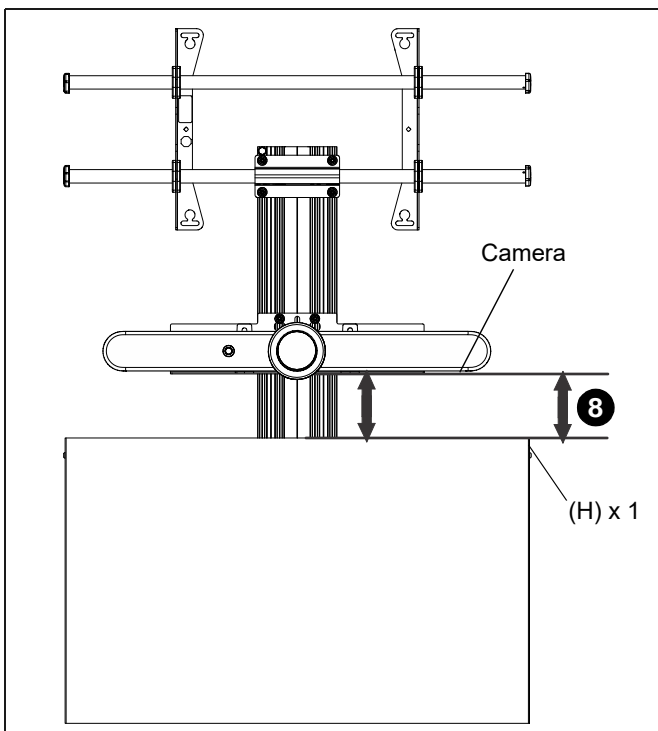

Figure 25

9. Mark the height of the space between the camera and storage box (H) on the small cover (K).
10. Cut the small cover (K) to the required size. (See Figure 26)

NOTE: Excess felt material from the small cover (K) will not be used in the final assembly.

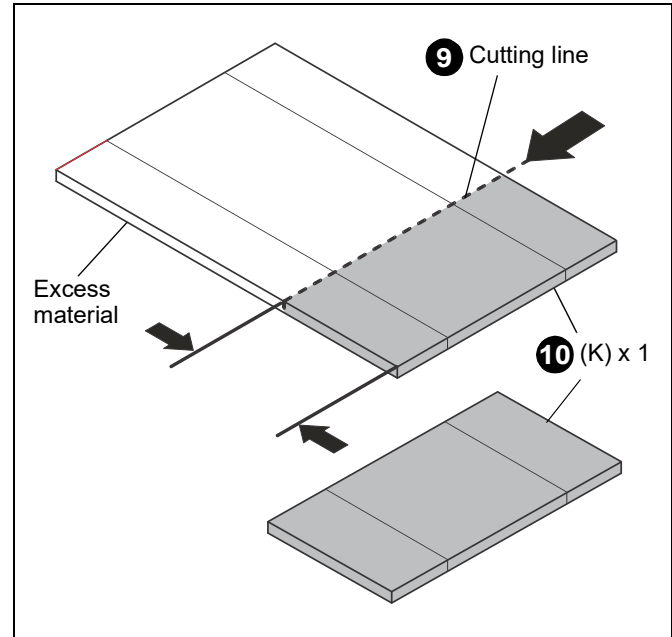

Figure 26

11. Press the edges of the small cover (K) into the outer slots of the upright extrusion (A) between the camera and the upper surface of the storage box (H). (See Figure 27)

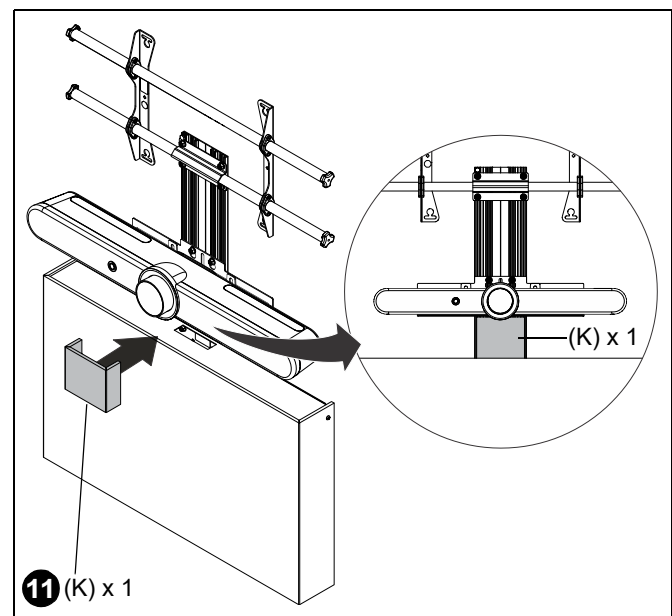

Figure 27

Secure Cover Attachment (OPTIONAL)

NOTE: The large cover (J) can be installed more securely if additional security is required.

1. Remove the large cover (J) from the storage box (H).
2. Remove the upper three magnets from the large cover (J).
3. Remove the four outside screws securing the upper mounting rail from the large cover (J). Rotate the mounting rail 180 degrees and reinstall to the cover. (See Figure 28)
4. Slide the large cover (J) onto the front face of the storage box from the side. (See Figure 29)

NOTE: The upper and lower mounting rails on the large cover (J) will hook into the channels on the storage box.

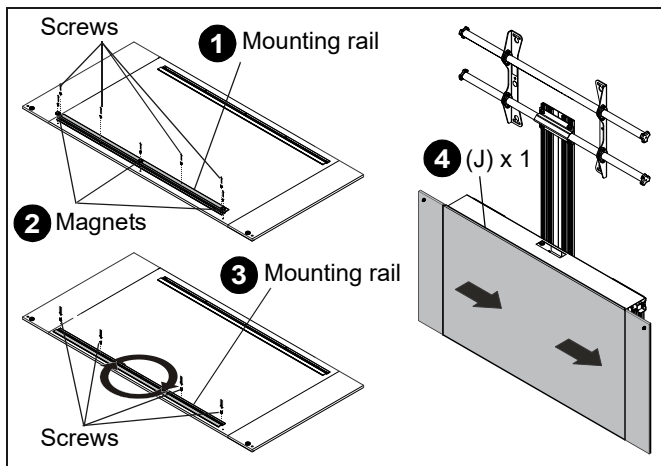

Figure 28

5. Secure the large cover (J) to the storage box (H) using two M6 x 25 mm screws (P). (See Figure 29)

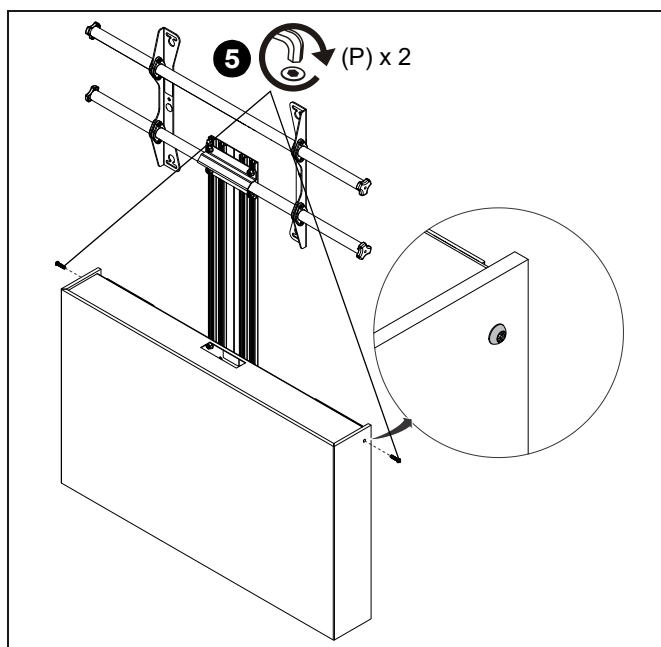

Figure 29

CHIEF®

A brand of  **legrand**

8800-003423 Rev01
 ©2026 Legrand | AV
www.legrandav.com
 01/2026

USA/International	A 10900 Red Circle Drive, Minnetonka, MN 55343
	P 800.582.6480 / 952.225.6000
	F 877.894.6918 / 952.894.6918
Europe	A Franklinstraat 14, 6003 DK Weert, Netherlands
	P +31 (0) 495 580 852
	F +31 (0) 495 580 845
Asia Pacific	A Office No. 918 on 9/F, Shatin Galleria 18-24 Shan Mei Street Fotan, Shatin, Hong Kong
	P 852 2145 4099
	F 852 2145 4477

