

4

3

2

1

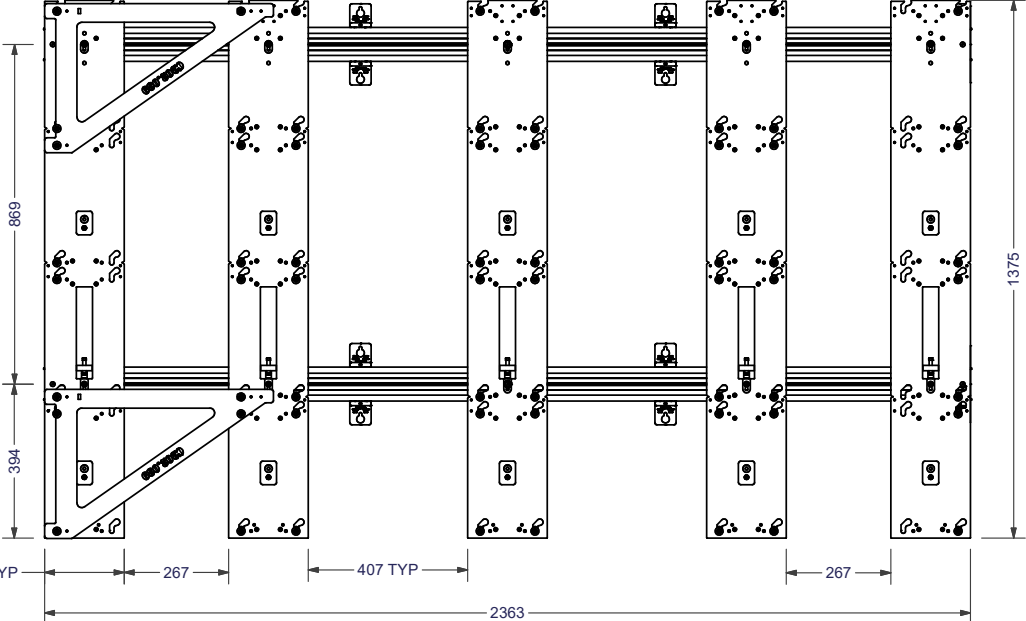

FRAME ONLY

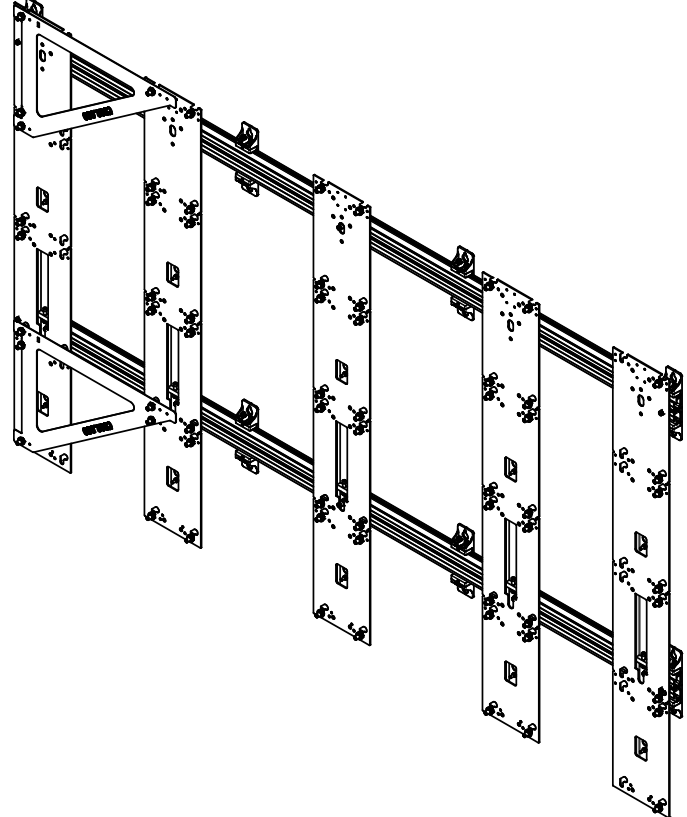



48 MIN

NOTES:
 1. FRAME WEIGHT = 49 kg (108 lbs)

Machining Tolerances (mm)	
0 < L ≤ 6	± 0.1
6 < L ≤ 30	± 0.2
30 < L ≤ 120	± 0.3
120 < L ≤ 400	± 0.5
400 < L ≤ 1000	± 0.8
1000 < L ≤ 2000	± 1.2
2000 < L ≤ 4000	± 2

UNITS IN MILLIMETERS

PROPRIETARY DRAWING NOTICE: THIS DOCUMENT CONTAINS CONFIDENTIAL, PROPRIETARY INFORMATION OF DRAPER, INC., IS THE PROPERTY OF DRAPER, INC., AND MUST BE RETURNED UPON REQUEST. NEITHER RECEIPT NOR POSSESSION THEREOF CONFERS ANY RIGHT TO OWN, REPRODUCE, USE, OR DISCLOSE IN WHOLE OR IN PART, ANY SUCH INFORMATION WITHOUT WRITTEN AUTHORIZATION FROM DRAPER, INC.

TOLERANCES UNLESS NOTED	DESIGNED BY: senochs	12/17/2019	 DRAPER, INC. 411 S. PEARL ST. SPICELAND, IN 47385 www.draperinc.com
	DRAWN BY: senochs	4/28/2020	
	CHECKED BY:		
	MATERIAL:		
 DO NOT SCALE	FINISH:		TITLE: FOUNDATION 4 X 4 UNILUMIN UpanelS WITHOUT TRIM
	DWG SIZE: B	REV: OF:	SHEET: 1 OF: 3 DWG NO.: 302101

4

3

2

1

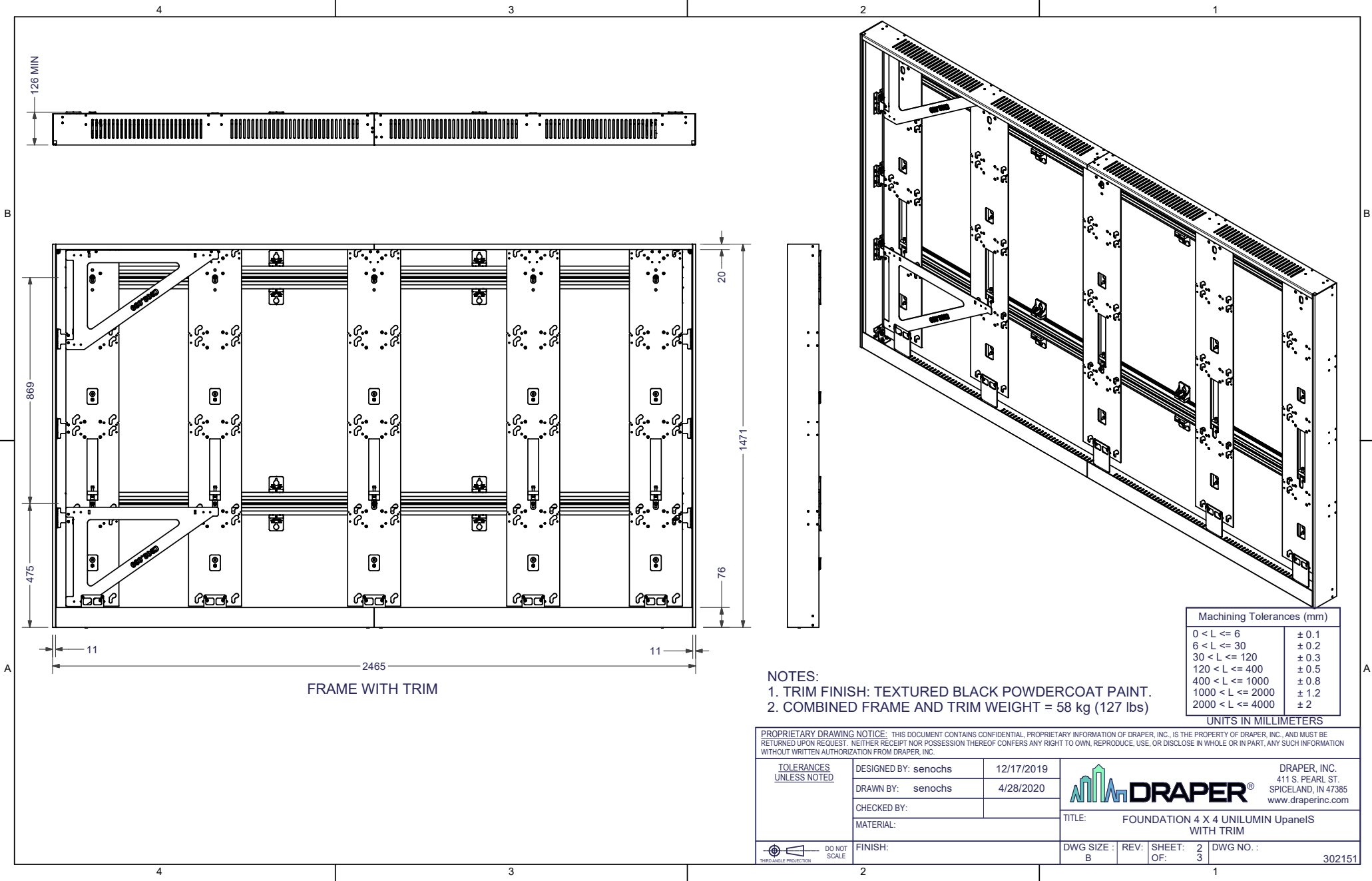



FRAME WITH TRIM

- NOTES:
 1. TRIM FINISH: TEXTURED BLACK POWDERCOAT PAINT.
 2. COMBINED FRAME AND TRIM WEIGHT = 58 kg (127 lbs)

Machining Tolerances (mm)	
0 < L ≤ 6	± 0.1
6 < L ≤ 30	± 0.2
30 < L ≤ 120	± 0.3
120 < L ≤ 400	± 0.5
400 < L ≤ 1000	± 0.8
1000 < L ≤ 2000	± 1.2
2000 < L ≤ 4000	± 2

UNITS IN MILLIMETERS

PROPRIETARY DRAWING NOTICE: THIS DOCUMENT CONTAINS CONFIDENTIAL, PROPRIETARY INFORMATION OF DRAPER, INC., IS THE PROPERTY OF DRAPER, INC., AND MUST BE RETURNED UPON REQUEST. NEITHER RECEIPT NOR POSSESSION THEREOF CONFERS ANY RIGHT TO OWN, REPRODUCE, USE, OR DISCLOSE IN WHOLE OR IN PART, ANY SUCH INFORMATION WITHOUT WRITTEN AUTHORIZATION FROM DRAPER, INC.

TOLERANCES UNLESS NOTED	DESIGNED BY: senochs	12/17/2019	 DRAPER, INC. 411 S. PEARL ST. SPICELAND, IN 47385 www.draperinc.com
	DRAWN BY: senochs	4/28/2020	
	CHECKED BY:		
	MATERIAL:		
 DO NOT SCALE	FINISH:		TITLE: FOUNDATION 4 X 4 UNILUMIN UpaneIS WITH TRIM
	DWG SIZE: B	REV: 2	SHEET: 2 OF: 3
			DWG NO.: 302151

4

3

2

1

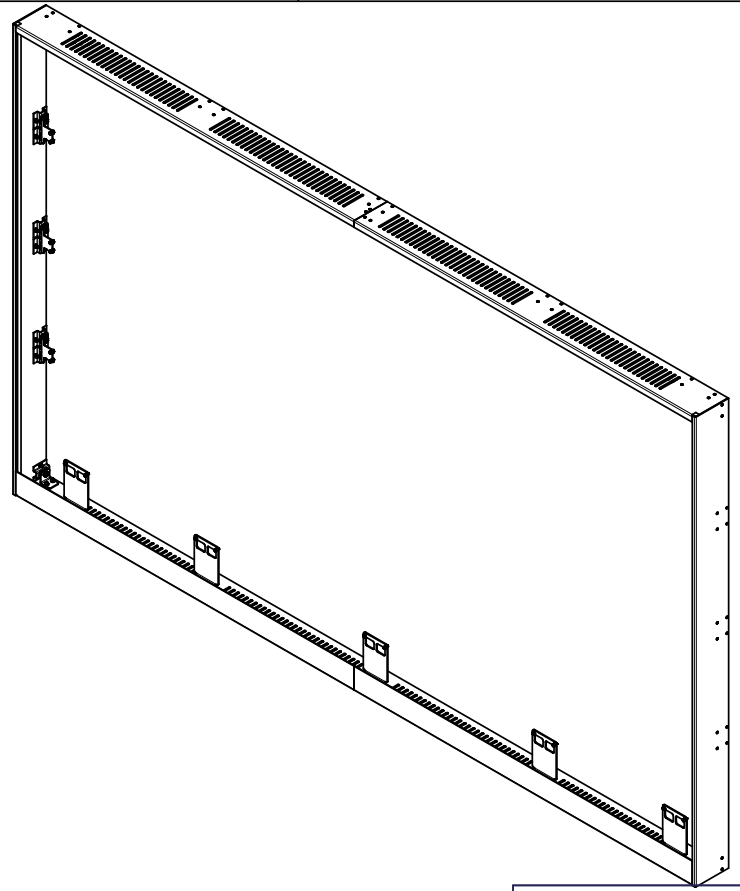
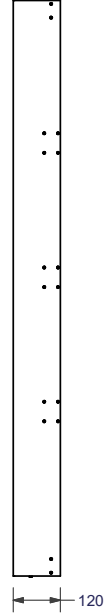
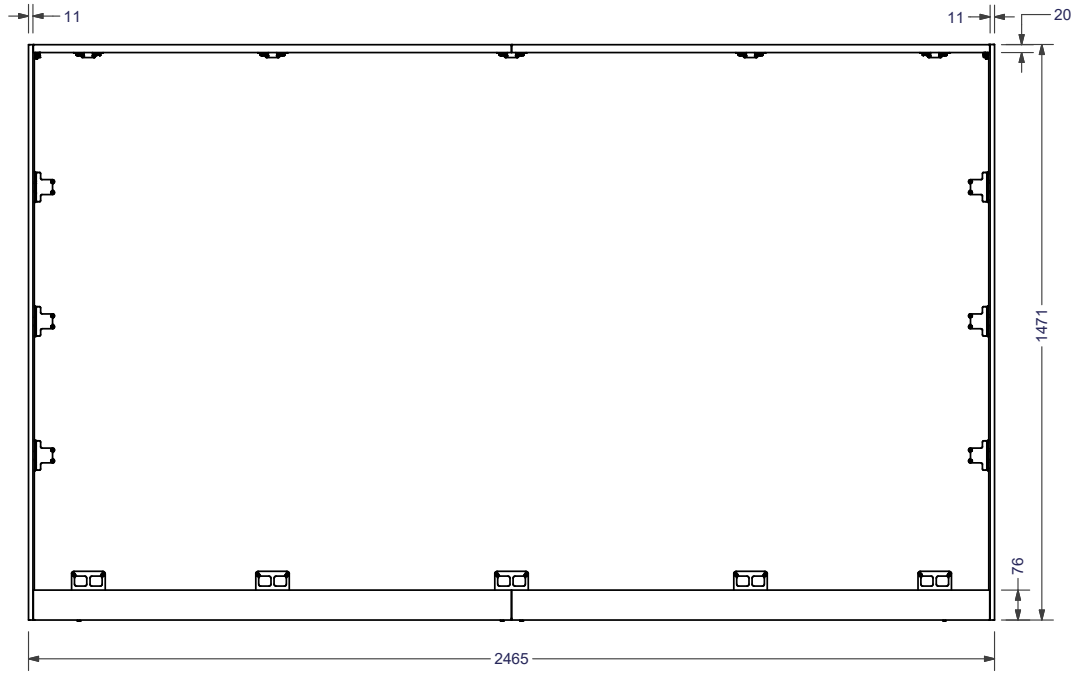
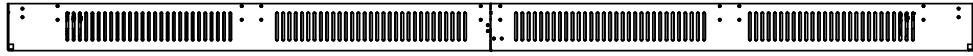



Machining Tolerances (mm)	
0 < L ≤ 6	± 0.1
6 < L ≤ 30	± 0.2
30 < L ≤ 120	± 0.3
120 < L ≤ 400	± 0.5
400 < L ≤ 1000	± 0.8
1000 < L ≤ 2000	± 1.2
2000 < L ≤ 4000	± 2

UNITS IN MILLIMETERS

NOTES:
 1. TRIM WEIGHT = 9 kg (19 lbs)

PROPRIETARY DRAWING NOTICE: THIS DOCUMENT CONTAINS CONFIDENTIAL, PROPRIETARY INFORMATION OF DRAPER, INC., IS THE PROPERTY OF DRAPER, INC., AND MUST BE RETURNED UPON REQUEST. NEITHER RECEIPT NOR POSSESSION THEREOF CONFERS ANY RIGHT TO OWN, REPRODUCE, USE, OR DISCLOSE IN WHOLE OR IN PART, ANY SUCH INFORMATION WITHOUT WRITTEN AUTHORIZATION FROM DRAPER, INC.

TOLERANCES UNLESS NOTED	DESIGNED BY: senochs	12/17/2019	 DRAPER, INC. 411 S. PEARL ST. SPICELAND, IN 47385 www.draperinc.com
	DRAWN BY: senochs	4/28/2020	
	CHECKED BY:		
	MATERIAL:		
 DO NOT SCALE	FINISH:		TITLE: FOUNDATION 4 X 4 UNILUMIN UpanelS TRIM ONLY
	DWG SIZE : B	REV: OF:	SHEET: 3 OF: 3
			DWG NO. :

4

3

2

1

B

A

B

A