



Cisco UCS C460 M4 High-Performance Rack-Mount Server

CONTENTS

OVERVIEW	3
DETAILED VIEWS	4
Chassis Front View	4
Chassis Rear View	5
BASE SERVER STANDARD CAPABILITIES and FEATURES	6
CONFIGURING the SERVER	9
STEP 1 VERIFY BASE SKU	10
STEP 2 CHOOSE CPU(S)	11
STEP 3 CHOOSE MEMORY	13
STEP 4 CHOOSE DRIVES	21
STEP 5 CHOOSE RAID CONFIGURATION	25
STEP 6 CHOOSE PCIe OPTION CARD(S)	30
STEP 7 CHOOSE PCIe RISERS	35
STEP 8 ORDER OPTIONAL NETWORK CARD ACCESSORIES	35
STEP 9 ORDER GPU CARDS and ACCESSORIES (OPTIONAL)	41
STEP 10 ORDER POWER SUPPLIES	43
STEP 11 SELECT AC POWER CORD(s)	44
STEP 12 ORDER OPTIONAL SLIDE RAIL KIT	47
STEP 13 ORDER OPTIONAL CABLE MANAGEMENT ARM	48
STEP 14 ORDER CISCO FLEXIBLE FLASH SD CARD MODULE (OPTIONAL)	49
STEP 15 ORDER USB DRIVE (OPTIONAL)	50
STEP 16 ORDER A TRUSTED PLATFORM MODULE	51
STEP 17 ORDER A BEZEL (OPTIONAL)	52
STEP 18 CHOOSE OPERATING SYSTEM AND VALUE-ADDED SOFTWARE	53
STEP 19 CHOOSE OPERATING SYSTEM MEDIA KIT	56
STEP 20 CHOOSE SERVICE and SUPPORT LEVEL	57
OPTIONAL STEP - ORDER RACKS	62
OPTIONAL STEP - ORDER PDU	63
SUPPLEMENTAL MATERIAL	64
CHASSIS	64
CPUs and DIMMs	65
Physical Layout	65
Memory Population Rules	66
Memory Population Order	66
RACKS	73
PDUs	75
KVM CABLE	76
TECHNICAL SPECIFICATIONS	77
Dimensions and Weight	77
Power Specifications	77
Environmental Specifications	79
Compliance Requirements	79

OVERVIEW

The Cisco UCS C460 M4 High-Performance Rack Server (*Figure 1*) is a four-rack-unit (4RU) server supporting the Intel Xeon E7-8800 v3/v4 or E7-4800 v3/v4 series processor family CPUs, with up to 6 terabytes (TB) of double-data-rate 3 (DDR3) or DDR4 memory¹ in 96 slots, and up to 12 small form factor (SFF), hot-swappable² SAS and SATA disk drives.

10 PCI Express (PCIe) slots support the Cisco UCS C-Series network adapters, with additional I/O provided by 2 Gigabit Ethernet LOM ports, 2 10-Gigabit Ethernet ports, and one dedicated out-of-band (OOB) management port. A separate PCIe slot is reserved inside the chassis for a RAID controller card.

Figure 1 Cisco UCS C460 M4 High-Density Rack Server

Front View



Rear View



Notes . . .

1. A maximum of 6 TB memory is available using 64 GB DIMMs.
2. Hot-swap replacement means that you do not have to precondition or shut down the component in software before you remove it.

DETAILED VIEWS

Chassis Front View

Figure 2 is a detailed front view of the Cisco UCS C460 M4 General-Purpose Rack Server.

Figure 2 Chassis Front View

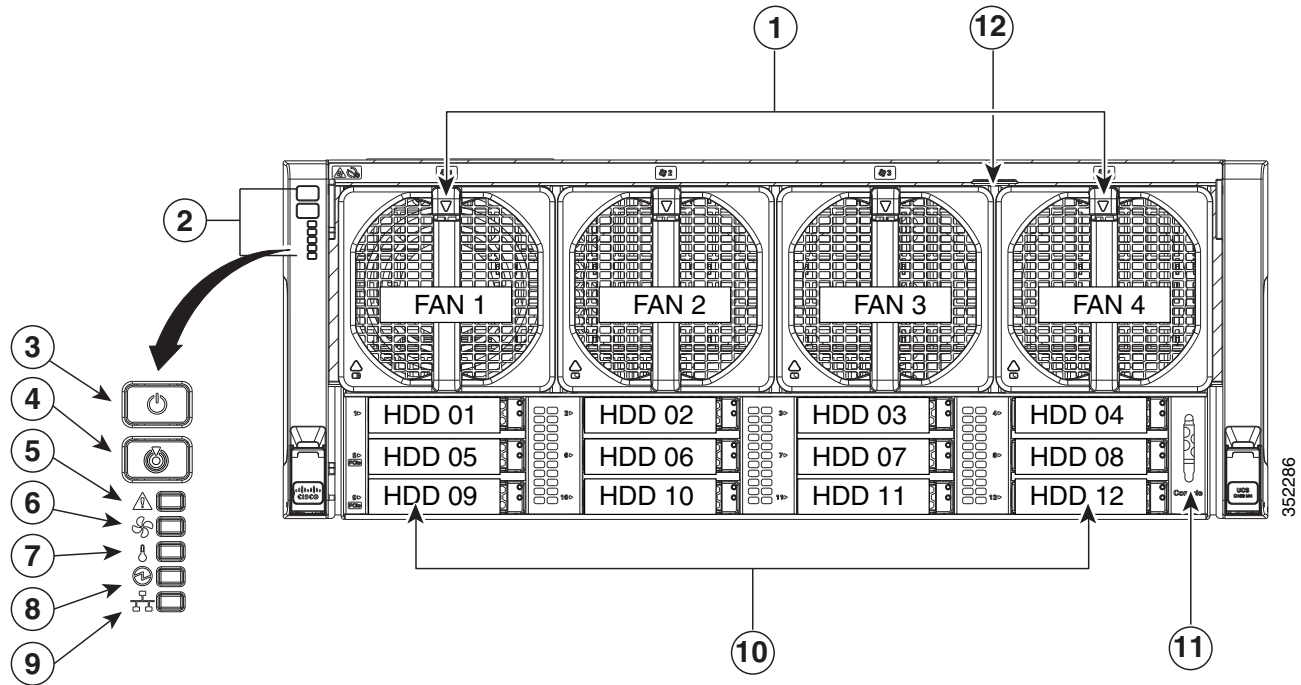

1	Cooling fans (hot-swappable and accessible from the front panel)	7	Temperature status LED
2	Operations panel	8	Power supply status LED
3	Power button/LED	9	Network link activity LED
4	Identification button/LED	10	SAS/SATA drive bays 1-12 (hot-swappable)
5	System status LED	11	KVM console connector (used with a KVM cable that provides two USBs, one VGA, and one serial connector) ¹
6	Fan status LED	12	Pull-out asset tag

Notes . . .

1. For more details on the KVM connector, see [KVM CABLE on page 76](#).

Chassis Rear View

Figure 3 shows the external features of the rear panel.

Figure 3 Chassis Rear View

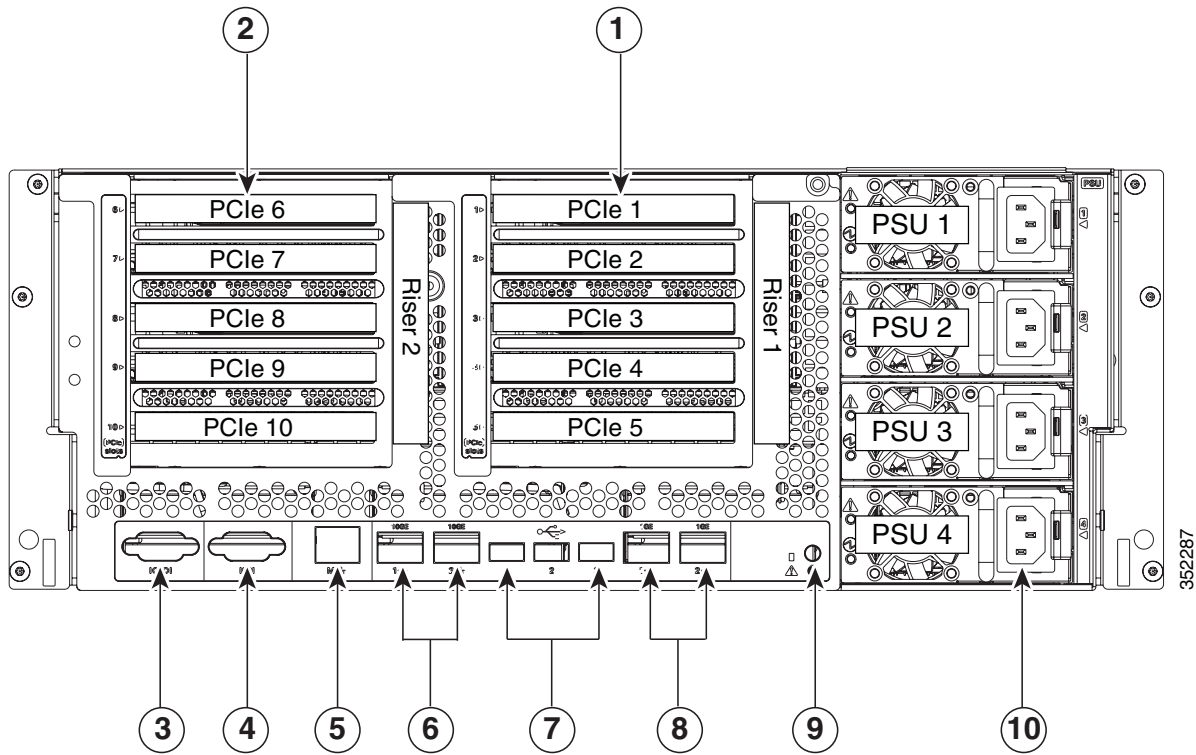

1	PCIe riser 1 (slots 1-5)	6	10 Gb Ethernet ports (two)
2	PCIe riser 2 (slots 6-10)	7	USB 2.0 ports (three)
3	Serial port (DB-9 connector)	8	1 Gb Ethernet ports (two)
4	VGA video port (DB-15 connector)	9	Rear identification LED
5	10/100/1000 Ethernet dedicated management port M1	10	Power supplies 1-4 (hot-swappable, redundant as 2+2)

BASE SERVER STANDARD CAPABILITIES and FEATURES

Table 1 lists the capabilities and features of the base server. Details about how to configure the server for a particular feature or capability (for example, number of processors, disk drives, or amount of memory) are provided in *CONFIGURING the SERVER on page 9*.

Table 1 Capabilities and Features



Capability/Feature	Description
Chassis	Four rack unit (4RU) chassis
CPU	<p>Either 2 or 4 Intel Xeon E7-8800 v3/v4 or E7-4800 v3/v4, series processor family CPUs</p> <p>Four power supplies are required for both 2-CPU and 4-CPU configurations.</p>
InfiniBand	The bus slots in this server support the InfiniBand architecture.
Chipset	Intel® C602J chipset
Memory	<p>Eight motherboard slots for memory riser boards. Each memory riser can hold up to 12 DIMMs, for a maximum DIMM population of 96 DIMMs. Each CPU can control 2 memory risers (up to 24 DIMMs). Memory risers are hot-pluggable¹.</p> <p>Maximum memory capacity is 6 TB². This is accomplished with 96 DIMMs, consisting of 48 DIMM kits (2 64 GB DIMMs per kit) in a 4-CPU configuration.</p>
Expansion slots	<p>There are 10 full-height PCIe expansion slots:</p> <ul style="list-style-type: none"> ■ Slot 1: CPU1 controlled, Gen-3 8x, 98-pin ■ Slot 2: CPU1 controlled, Gen-3 16x, NCSI, 230-pin ■ Slot 3: CPU2 controlled, Gen-3 4x, NCSI, 230-pin ■ Slot 4: CPU2 controlled, Gen-3 8x, NCSI, 230-pin ■ Slot 5: CPU2 controlled, Gen-3 8x, NCSI, 230-pin ■ Slot 6: CPU4 controlled, Gen-3 8x, 98-pin ■ Slot 7: CPU3 controlled, Gen-3 16x, NCSI, 230-pin ■ Slot 8: CPU4 controlled, Gen-3 8x, NCSI, 230-pin ■ Slot 9: CPU3 controlled, Gen-3 16x, NCSI, 230-pin ■ Slot 10: CPU4 controlled, Gen-3 8x, NCSI, 230-pin <hr/> <p> NOTE: CPUs must be installed as indicated to support specific slots. The CPU installation options are either CPU1 and CPU2 or CPU1, CPU2, CPU3, and CPU4. See <i>CHOOSE PCIe OPTION CARD(S) on page 30</i> for more details.</p>
Flexible Drive Connectors	<p>Twelve connectors are available from the front of the server, and flexibly support hot-pluggable drive sleds or PCIe devices, as follows:</p> <ul style="list-style-type: none"> ■ All 12 connectors support hot-plug SAS/SATA hard disk drives (HDDs) or solid-state drives (SSDs) ■ Two of the 12 connectors additionally support hot-plug PCIe storage devices

Table 1 Capabilities and Features *(continued)*

Capability/Feature	Description												
Storage controller	<p>Factory-configured RAID support options:</p> <ul style="list-style-type: none"> ■ LSI MegaRAID SAS 9361CV-8i controller, for support of up to 8 internal SAS or SATA drives. Supports RAID 0, 1, 5, 6, 10, 50, and 60. This RAID controller has an on-board 1 GB cache and chassis-mounted (remote) supercap for data cache power backup. ■ Cisco 12G SAS Modular 8-port RAID controller. This card supports up to 8 internal SAS or SATA drives and is ordered with a 512 MB Flash-Backed Write Cache (FBWC). The card supports JBOD as well as RAID 0, 1, 5, 10, 50. ■ Cisco 12G SAS Modular 12-port RAID controller, supporting up to 12 drives. This card is purchased along with one of the onboard Flash-Backed Write Cache (FBWC) upgrade options shown in the table below <table border="1" data-bbox="474 732 1419 955"> <thead> <tr> <th>RAID Card Version</th> <th>Supported RAID Levels</th> <th>Onboard FBWC</th> </tr> </thead> <tbody> <tr> <td>UCSC-MRAID12G-1GB</td> <td>JBOD, 0, 1, 5, 6, 10, 50, 60</td> <td>1 GB</td> </tr> <tr> <td>UCSC-MRAID12G-2GB</td> <td>JBOD, 0, 1, 5, 6, 10, 50, 60</td> <td>2 GB</td> </tr> <tr> <td>UCSC-MRAID12G-4GB</td> <td>JBOD, 0, 1, 5, 6, 10, 50, 60</td> <td>4 GB</td> </tr> </tbody> </table>	RAID Card Version	Supported RAID Levels	Onboard FBWC	UCSC-MRAID12G-1GB	JBOD, 0, 1, 5, 6, 10, 50, 60	1 GB	UCSC-MRAID12G-2GB	JBOD, 0, 1, 5, 6, 10, 50, 60	2 GB	UCSC-MRAID12G-4GB	JBOD, 0, 1, 5, 6, 10, 50, 60	4 GB
RAID Card Version	Supported RAID Levels	Onboard FBWC											
UCSC-MRAID12G-1GB	JBOD, 0, 1, 5, 6, 10, 50, 60	1 GB											
UCSC-MRAID12G-2GB	JBOD, 0, 1, 5, 6, 10, 50, 60	2 GB											
UCSC-MRAID12G-4GB	JBOD, 0, 1, 5, 6, 10, 50, 60	4 GB											
	<p>There is one dedicated onboard PCIe slot that accommodates any of the RAID controller cards. These RAID controllers cannot control PCIe drives.</p> <ul style="list-style-type: none"> ■ Cisco 9300-8E 12G SAS PCIe external drive controller <ul style="list-style-type: none"> • Cisco 12G SAS 9300-8e HBA with 8 external ports. SAS 3.0 compliant. Provides eight external SAS+SATA ports (up to 1024 non-RAID external devices). There is no cache or cache power backup. 												
Internal storage devices	<p>Up to 12 SFF 2.5” SAS or SATA HDDs or SSDs. In addition, the server accommodates up to two NVMe SFF 2.5” drives, in drive bays 5 and 9 only. These SSDs are controlled through the PCIe bus (drive bay 5 is controlled through CPU2 and drive bay 9 is controlled through CPU4).</p> <p>UCS Storage Accelerators are also available. These PCIe flash storage devices plug into the rear-accessible PCIe slots and provide independent high-speed storage.</p>												
Cisco Flexible Flash drive	The server has provision for two optional blank internal Cisco Flexible Flash drives (SD cards), on the internal media riser.												
Internal USB	The server includes one internal USB 2.0 slot on the internal media riser.												
WoL	The 1-Gb Base-T Ethernet LAN ports support the wake-on-LAN (WoL) standard.												
ACPI	This server supports the advanced configuration and power interface (ACPI) 4.0 standard.												

Table 1 Capabilities and Features *(continued)*

Capability/Feature	Description
Video	<p>The Cisco Integrated Management Controller (CIMC) provides video using the Matrox G200e video/graphics controller:</p> <ul style="list-style-type: none"> ■ Integrated 2D graphics core with hardware acceleration ■ DDR2/3 memory interface supports up to 512 MB of addressable memory (8 MB is allocated by default to video memory) ■ Supports display resolutions up to 1920 x 1200 16bpp @ 60Hz ■ High-speed integrated 24-bit RAMDAC ■ Single lane PCI-Express host interface running at Gen 1 speed
Interfaces	<ul style="list-style-type: none"> ■ Rear panel <ul style="list-style-type: none"> • One 10/100/1000 dedicated management Ethernet ports • Two 1-Gigabit ports (10/100/1000 Mbps capable). These integrated Gigabit ports support the Wake on LAN (WoL) and TCP/IP Offload Engine (TOE) standards • Two 10-Gigabit Base-T Ethernet ports (1 Gbps/10 Gbps capable) • One RS232 serial connector • One 15-pin VGA connector • Three USB 2.0 connectors ■ Front panel <ul style="list-style-type: none"> • One KVM connector
Power subsystem	<ul style="list-style-type: none"> ■ Power supplies are hot-swappable, rear-accessible, and redundant as 2+2
	<div style="border: 1px solid black; padding: 5px;">  <p>For more information about your server's power consumption, use the power calculator accessible at http://ucspowercalc.cisco.com</p> </div>
Fans	<p>Chassis:</p> <ul style="list-style-type: none"> ■ 4 fans, hot-swappable <p>Power supply:</p> <ul style="list-style-type: none"> ■ Each of the 4 power supplies is equipped with a fan.
Integrated management processor	<p>The built-in Cisco Integrated Management Controller (CIMC) GUI or CLI interface enables you to monitor the server inventory, health, and system event logs.</p>

Notes . . .

1. Hot-pluggable = Software shutdown of the component is required before removing while the server is powered on.
2. With 64 GB DIMMs.

CONFIGURING the SERVER

Follow these steps to configure the Cisco UCS C460 M4 High-Performance Rack Server:

- *STEP 1 VERIFY BASE SKU, page 10*
- *STEP 2 CHOOSE CPU(S), page 11*
- *STEP 3 CHOOSE MEMORY, page 13*
- *STEP 4 CHOOSE DRIVES, page 21*
- *STEP 5 CHOOSE RAID CONFIGURATION, page 25*
- *STEP 6 CHOOSE PCIe OPTION CARD(S), page 30*
- *STEP 7 CHOOSE PCIe RISERS, page 35*
- *STEP 8 ORDER OPTIONAL NETWORK CARD ACCESSORIES, page 36*
- *STEP 9 ORDER GPU CARDS and ACCESSORIES (OPTIONAL), page 41*
- *STEP 10 ORDER POWER SUPPLIES, page 43*
- *STEP 11 SELECT AC POWER CORD(s), page 44*
- *STEP 12 ORDER OPTIONAL SLIDE RAIL KIT, page 47*
- *STEP 13 ORDER OPTIONAL CABLE MANAGEMENT ARM, page 48*
- *STEP 14 ORDER CISCO FLEXIBLE FLASH SD CARD MODULE (OPTIONAL), page 49*
- *STEP 15 ORDER USB DRIVE (OPTIONAL), page 50*
- *STEP 16 ORDER A TRUSTED PLATFORM MODULE, page 51*
- *STEP 17 ORDER A BEZEL (OPTIONAL), page 52*
- *STEP 19 CHOOSE OPERATING SYSTEM MEDIA KIT, page 56*
- *STEP 20 CHOOSE SERVICE and SUPPORT LEVEL, page 57*
- *OPTIONAL STEP - ORDER RACKS on page 62*
- *OPTIONAL STEP - ORDER PDU on page 63*

STEP 1 VERIFY BASE SKU

Verify the product ID (PID) of the base server as shown in [Table 2](#).

Table 2 PID of the Base C460 M4 Rack Server

Product ID (PID)	Description
UCSC-C460-M4	UCS C460 M4 base chassis no CPU/DIMM/HDD/PCIe/memory risers

The base server:

■ Includes:

- Blanking panels for empty drive locations (to maintain cooling air flow)
- Rail kit

■ Does not include:

- CPUs
- DIMMs
- Memory risers
- Power supplies
- Hard disk drives (HDDs)
- Solid-state Drives (SSDs)
- Plug-in PCIe cards
- PCIe risers



NOTE: Use the steps on the following pages to configure the server with the components that you want to include.

STEP 2 CHOOSE CPU(S)

The standard CPU features are:

- Intel Xeon E7-8800 v3/v4 or E7-4800 v3/v4 series processor family CPUs
- Intel C602J chipset
- Cache size of up to 45 MB for v3 CPUs and 60 MB for v4 CPUs

Choose CPUs

The available CPUs are listed in [Table 3](#).

Table 3 Available CPUs: Intel Xeon E7-8800 v3/v4, E7-4800 v3/v4 Family

Product ID (PID)	Intel Number	Clock Freq (GHz)	Power (W)	Cache Size (MB)	Cores	QPI (GT/s)	Highest DDR DIMM Clock Support (MHz)
v4 CPUs (must be configured with DDR4 memory and DDR4 memory risers)							
UCS-CPU-E74809E	E7-4809 v4	2.1	115	20	8	6.4	1866
UCS-CPU-E74820E	E7-4820 v4	2.0	115	25	10	6.4	1866
UCS-CPU-E74830E	E7-4830 v4	2.0	115	35	14	8.0	1866
UCS-CPU-E74850E	E7-4850 v4	2.1	115	40	16	8.0	1866
UCS-CPU-E78860E	E7-8860 v4	2.2	140	45	18	9.6	1866
UCS-CPU-E78867E	E7-8867 v4	2.4	165	45	18	9.6	1866
UCS-CPU-E78870E	E7-8870 v4	2.1	140	50	20	9.6	1866
UCS-CPU-E78880E	E7-8880 v4	2.2	150	55	22	9.6	1866
UCS-CPU-E78890E	E7-8890 v4	2.2	165	60	24	9.6	1866
UCS-CPU-E78891E	E7-8891 v4	2.8	165	60	10	9.6	1866
UCS-CPU-E78893E	E7-8893 v4	3.2	140	60	4	9.6	1866
UCS-CPU-E78894E	E7-8894 v4	2.4	165	60	24	9.6	1866
v3 CPUs (must be configured with DDR4 memory and DDR4 memory risers)							
UCS-CPU-E74809D	E7-4809 v3	2.0	115	20	8	6.4	1866
UCS-CPU-E74820D	E7-4820 v3	1.9	115	25	10	6.4	1866
UCS-CPU-E74830D	E7-4830 v3	2.1	115	30	12	8.0	1866
UCS-CPU-E74850D	E7-4850 v3	2.2	115	35	14	8.0	1866
UCS-CPU-E78860D	E7-8860 v3	2.2	140	40	16	9.6	1866
UCS-CPU-E78870D	E7-8870 v3	2.1	140	45	18	9.6	1866
UCS-CPU-E78880D	E7-8880 v3	2.3	150	45	18	9.6	1866
UCS-CPU-E78890D	E7-8890 v3	2.5	165	45	18	9.6	1866
UCS-CPU-E78891D	E7-8891 v3	2.8	165	45	10	9.6	1866
UCS-CPU-E78893D	E7-8893 v3	3.2	140	45	4	9.6	1866

Table 3 Available CPUs: Intel Xeon E7-8800 v3/v4, E7-4800 v3/v4 Family (*continued*)

Product ID (PID)	Intel Number	Clock Freq (GHz)	Power (W)	Cache Size (MB)	Cores	QPI (GT/s)	Highest DDR DIMM Clock Support (MHz)
UCS-CPU-E78880ID	E7-8880L v3	2.0	115	45	18	9.6	1866
UCS-CPU-E78867D	E7-8867 v3	2.5	165	45	16	9.6	1866

Approved Configurations

(1) Two-CPU Configuration

- Choose two identical CPUs from [Table 3](#).

(2) Four-CPU Configuration

- Choose four identical CPUs from [Table 3](#).

Caveats

- You must select either two or four identical processors.
- v3/v4 CPUs must be configured with DDR4 DIMMs and DDR4 memory risers.

STEP 3 CHOOSE MEMORY

The standard memory features are:

- Plug-In Memory Riser Boards
 - Up to 12 DIMMs per riser board
 - Riser boards plug vertically into the motherboard
 - Four riser boards for 2-CPU option
 - Eight riser boards for 4-CPU option
- DIMMs
 - Clock speed: 1600 MHz for DDR3 DIMMs and 1866 MHz for DDR4 DIMMS
 - Ranks per DIMM: 2, 4, or 8
 - Operational voltage: 1.5 or 1.35 V
 - Registered DIMM (RDIMM) or load-reduced registered DIMM (LRDIMM)
- Each CPU controls four serial memory interface 2 (SMI-2) channels. Memory buffers on the memory risers convert each SMI channel into two DDR3 subchannels. There are two memory risers for each CPU. Memory is organized as three DIMMs per subchannel, as shown in [Figure 4](#).

Figure 4 C460 M4 Memory Organization

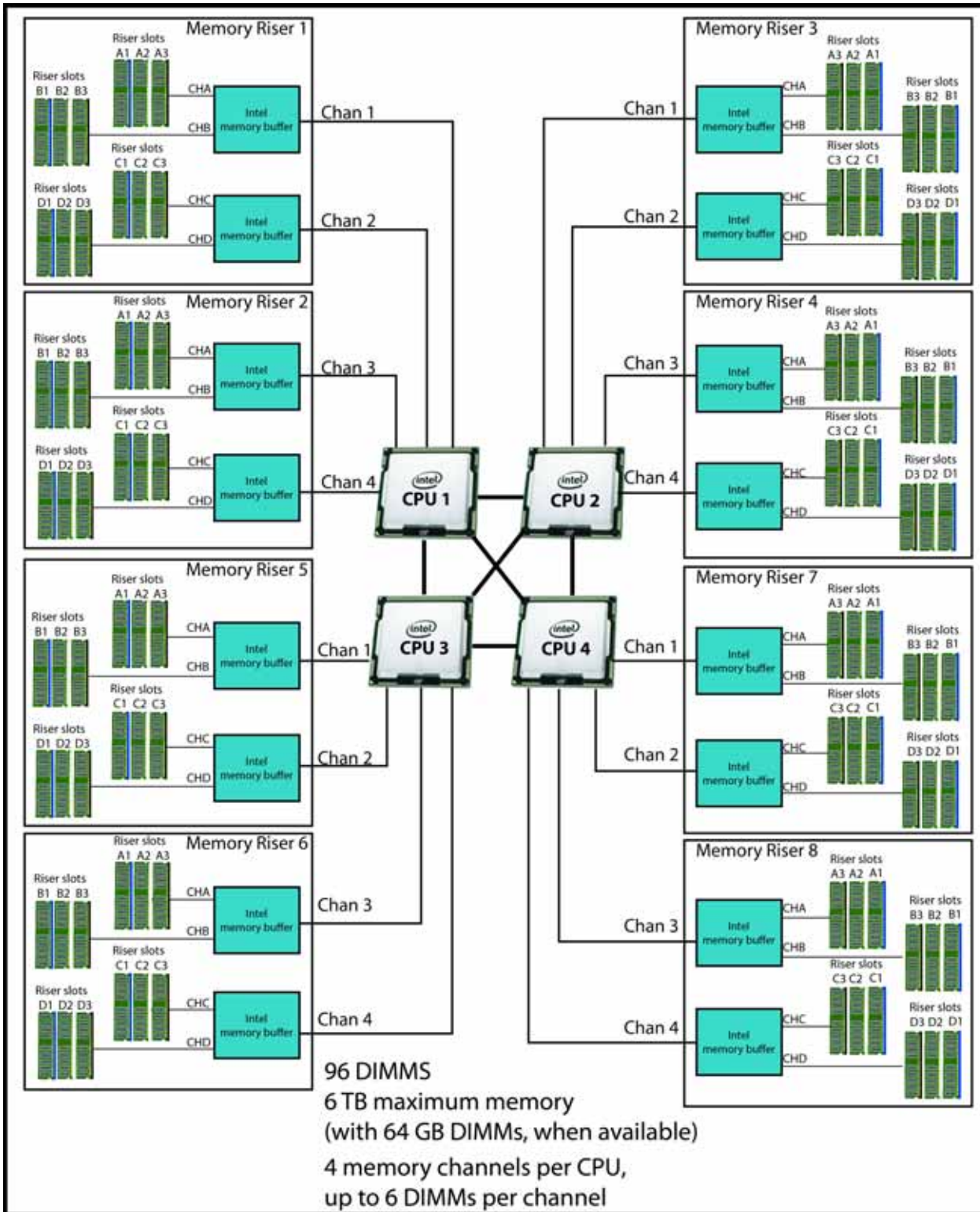

Choose Memory Riser Boards

You may choose riser boards as follows:

- Four memory riser boards for a two-CPU system, or
- Eight memory riser boards for a four-CPU system.

Table 4 Available Memory Riser Boards

Product ID (PID)	PID Description	Max DIMMs per Riser
Riser Board Options		
UCSC-MRBD2-12	Memory riser board with 12 DDR4 DIMM slots	12

Approved Configurations

(1) Two-CPU System

- Choose four memory riser boards from [Table 4](#).

(1) Four-CPU System

- Choose eight memory riser boards from [Table 4](#).

Caveats

- You should order enough risers with enough sockets to accommodate your maximum foreseeable memory needs.

Choose DIMMs and Memory Mirroring

Select the memory configuration and whether or not you want the memory mirroring option. The available memory DIMMs and mirroring option are listed in [Table 5](#).



NOTE: When memory mirroring is enabled, the memory subsystem simultaneously writes identical data to two channels. If a memory read from one of the channels returns incorrect data due to an uncorrectable memory error, the system automatically retrieves the data from the other channel. A transient or soft error in one channel does not affect the mirrored data, and operation continues unless there is a simultaneous error in exactly the same location on a DIMM and its mirrored DIMM. Memory mirroring reduces the amount of memory available to the operating system by 50% because only one of the two populated channels provides data.

DDR3 DIMMs are orderable as kits, with two DIMMs per kit. DDR4 DIMMs are orderable as single DIMMs. Choose the desired number of DIMMs and the memory mirroring option if desired. The available memory DIMMs are listed in [Table 5](#).

Table 5 Available DIMMs and DIMM Kits (2 DIMMs per kit)

Product ID (PID)	PID Description	Voltage (V)	Ranks/DIMM
DDR4 DIMM Options (use the DDR4 memory riser board, UCSC-MRBD2-12)			
UCS-ML-1X644RU-G ¹	64 GB DDR4-2133/2400-MHz LRDIMM/4R/x4/1.2v	1.2	4
UCS-ML-1X324RU-G	32 GB DDR4-2133/2400-MHz LRDIMM/4R/x4/1.2v	1.2	4
UCS-MR-1X322RU-G	32 GB DDR4-2133/2400-MHz RDIMM/2R/x4/1.2v	1.2	2
UCS-MR-1X161RV-G	16 GB DDR4-2133MHz/2400-MHz RDIMM/single rank/x4/1.2v	1.2	1
UCS-MR-1X162RU-G	16 GB DDR4-2133/2400 MHz RDIMM/2R/x4/1.2v	1.2	2
UCS-MR-1X081RU-G	8 GB DDR4-2133/2400 MHz RDIMM/1R/x4/1.2v	1.2	1
Memory Mirroring Option			
N01-MMIRROR	Memory mirroring option		

Approved Configurations

(1) Minimum Configuration without memory mirroring

- The minimum configuration without memory mirroring is one memory riser installed on a slot for CPU1 or CPU2, with one DIMM. The minimum total DIMM capacity must meet the requirements of the OS installed.

(2) Maximum Configuration without memory mirroring

- Eight memory risers with 12 DIMMs each (96 DIMMs total).

(3) Minimum Configuration with memory mirroring

- One memory riser with at least two DIMM pairs

(4) Maximum Configuration with memory mirroring

- Eight memory risers with at least two DIMM pairs per riser (16 DIMMs total) and up to six DIMM pairs per riser (96 DIMMs total).



NOTE: There are three memory mirroring modes:

- 1 Intra-socket mirroring
- 2 Inter-socket cross-memory-controller mirroring
- 3 Inter-socket complete master-slave mirroring

Mirroring mode can be configured using the UCS Manager BIOS Policy RAS Memory tab.

Available DIMM Configurations

See [Table 6](#) for the possible DIMM configurations in 2-CPU and 4-CPU systems.

Table 6 Available DIMM Configurations

Desired DIMMs per CPU	2-CPU System		4-CPU System	
	DIMM Kit Qty (see Table 5 on page 16)	Total DIMMs	DIMM Kit Qty (see Table 5 on page 16)	Total DIMMs
2	2	4	4	8
4	4	8	8	16
6	6	12	12	24
8	8	16	16	32
10	10	20	20	40
12	12	24	24	48
14	14	28	28	56
16	16	32	32	64
18	18	36	36	72
20	20	40	40	80
22	22	44	44	88
24	24	48	48	96

Caveats

- **Memory Mode.** System speed is dependent on how many DIMMs are populated per channel, the CPU DIMM speed support, and the BIOS memory mode. The BIOS default memory mode is performance mode. However, the BIOS can be changed to support lockstep mode.

- Memory Performance Mode. In this mode, the main memory channel from the CPU to the memory buffer runs at double the clock rate of each of the two memory subchannels from the buffer to the DIMMs, and each DIMM subchannel is accessed sequentially. For example, if the CPU channel clock speed is 2667 MHz, each of the DIMM subchannels operates at 1333 MHz. For this reason, performance mode is referred to as 2:1. Performance mode does not provide data protection, but can yield up to 1.5 times the performance of lockstep mode and is the best choice for high throughput requirements.
- Memory Lockstep Mode. In this mode, the main memory channel from the CPU to the memory buffer runs at the same clock rate of each of the two memory subchannels from the buffer to the DIMMs, and both DIMM subchannels are accessed simultaneously for a double-width access. For example, if the CPU channel clock speed is 1600 MHz, each of the DIMM subchannels operates at 1600 MHz. For this reason, lockstep mode is referred to as 1:1. Memory lockstep mode provides protection against both single-bit and multi-bit errors. Memory lockstep lets two memory channels work as a single channel, moving a data word two channels wide and providing eight bits of memory correction.

■ v3 and v4 CPUs must be configured with DDR4 DIMMs and DDR4 memory risers.

Table 7 CPU Effect on DDR4 DIMM Performance

CPU Memory Mode	Advanced CPU ¹ 9.6 GT/s QPI	Standard CPU ² 8.0 GT/s QPI	Basic CPU ³ 6.4 GT/s QPI
Lockstep Mode (1:1)	1866 MHz	1600 MHz	1333 MHz
Performance Mode (2:1)	1600 MHz	1333 MHz	1333 MHz

Notes . . .

1. CPU examples: E7-8860/8870/8880/8890/8891/8893/8880L/8867 v3
2. CPU examples: E7-4830/4850 v3
3. CPU example: E7-4809/4820 v3

■ DIMM Clock Speeds

DIMMs run at various clock speeds depending on the DIMM voltage and number of DIMMs per channel. See [Table 8](#), [Table 9](#), and [Table 10](#).

Table 8 DDR3 DIMM Performance (at 1.5 V)

DIMM GB/Rank/Type	Performance Mode (2:1) 1.5 V DIMM			Lockstep Mode (1:1) 1.5 V DIMM		
	1 DPC	2 DPC	3 DPC	1 DPC	2 DPC	3 DPC
8 GB/2R/RDIMM	1333 MHz	1333 MHz	1066 MHz	1333 MHz	1333 MHz	1066 MHz
16 GB/2R/RDIMM	1333 MHz	1333 MHz	1066 MHz	1333 MHz	1333 MHz	1066 MHz
32 GB/4R/LRDIMM	1333 MHz	1333 MHz	1333 MHz	1600 MHz	1600 MHz	1333 MHz
64 GB/8R/LRDIMM	1066 MHz	1066 MHz	1066 MHz	1066 MHz	1066 MHz	1066 MHz

Table 9 DDR3 DIMM Performance (at 1.35 V)

DIMM GB/Rank/Type	Performance Mode (2:1) 1.35 V DIMM			Lockstep Mode (1:1) 1.35 V DIMM		
	1 DPC	2 DPC	3 DPC	1 DPC	2 DPC	3 DPC
8 GB/2R/RDIMM	1333 MHz	1066 MHz	N/A	1333 MHz	1066 MHz	N/A
16 GB/2R/RDIMM	1333 MHz	1066 MHz	N/A	1333 MHz	1066 MHz	N/A
32 GB/4R/LRDIMM	1333 MHz	1333 MHz	N/A	1333 MHz	1333 MHz	N/A
64 GB/8R/LRDIMM	N/A	N/A	N/A	N/A	N/A	N/A

Table 10 DDR4 DIMM Performance (at 1.2 V)

DIMM GB/Rank/Type	Performance Mode (2:1) 1.2 V DIMM			Lockstep Mode (1:1) 1.2 V DIMM		
	1 DPC	2 DPC	3 DPC	1 DPC	2 DPC	3 DPC
8 GB/1R/RDIMM	1600 MHz	1600 MHz	1600 MHz	1866 MHz	1866 MHz	1600 MHz
16 GB/2R/RDIMM	1600 MHz	1600 MHz	1333 MHz	1866 MHz	1866 MHz	1333 MHz
32 GB/2R/RDIMM	1600 MHz	1600 MHz	1333 MHz	1866 MHz	1866 MHz	1333 MHz
32 GB/4R/LRDIMM	1600 MHz	1600 MHz	1600 MHz	1866 MHz	1866 MHz	1600 MHz
64 GB/4R/LRDIMM	1600 MHz	1600 MHz	1600 MHz	1866 MHz	1866 MHz	1600 MHz

- The minimum DIMM configuration is at least one DIMM pair installed in a memory riser on either CPU1 or CPU2. All four CPUs can run from a single DIMM pair.

- DIMMs are required to be populated in pairs. DIMMs for this server are available as two-DIMM kits.
- The DIMMs in any given pair must be identical.
- Any DIMM installed in a memory riser corresponding to an empty CPU slot becomes inaccessible.
- For optimal performance, distribute DIMMs evenly across all installed CPUs and memory buffers.
- Do not mix RDIMMs and LRDIMMs.
- DIMMs within a channel are populated starting with the DIMMs farthest from the memory buffer in a fill-farthest approach.
- Matched pairs of risers on paired DDR3 channels must have identical DIMM configurations.
- If a system uses 64 GB DIMMs, the maximum ambient temperature is 32 °C (89.6 °F). In addition, systems with 64 GB DIMMs cannot implement any GPUs.

For more information about memory, see [CPUs and DIMMs on page 65](#).

STEP 4 CHOOSE DRIVES

Choose HDDs and SSDs

The standard hard disk drive (HDD) and solid-state drive (SSD) features are:

- 2.5-inch small form factor
- Hot-swappable
- Sled-mounted

The available drives are listed in [Table 11](#).

Table 11 Available Hot-Pluggable Sled-Mounted HDDs and SSDs

Product ID (PID)	PID Description	Drive Type	Capacity
HDDs			
12 Gbps Drives			
UCS-HD300G15K12G	300 GB 12G SAS 15K RPM SFF HDD	SAS	300 GB
UCS-HD450G15K12G	450 GB 12G SAS 15K RPM SFF HDD	SAS	450 GB
UCS-HD600G15KS4K ¹	600GB 12G SAS 15K RPM SFF HDD (4K sector size format)	SAS	600 GB
UCS-HD600G15K12G	600 GB 12G SAS 15K RPM SFF HDD	SAS	600 GB
UCS-HD1T7KS4K1	1 TB 12G SAS 7.2K RPM SFF HDD (4K sector size format)	SAS	1 TB
UCS-HD12TB10KS4K ¹	1.2 TB 12G SAS 10K RPM SFF HDD (4K sector size format)	SAS	1.2 TB
UCS-HD18TB10KS4K ¹	1.8 TB 12G SAS 10K RPM SFF HDD (4K sector size format)	SAS	1.8 TB
UCS-HD2T7KS4K ¹	2 TB 12G SAS 7.2K RPM SFF HDD (4K sector size format)	SAS	2 TB
UCS-HD600G10KS4K ¹	600 GB 12G SAS 10K RPM SFF HDD (4K sector size format)	SAS	600 GB
UCS-HD600G15K12G	600 GB 12G SAS 15K RPM SFF HDD	SAS	600 GB
UCS-HD450G15K12G	450 GB 12G SAS 15K RPM SFF HDD	SAS	450 GB
UCS-HD300G15K12G	300 GB 12G SAS 15K RPM SFF HDD	SAS	300 GB
UCS-HD12TB10K12G	1.2 TB 12G SAS 10K RPM SFF HDD	SAS	1.2 TB
UCS-HD900G10KS4K ¹	900GB 12G SAS 10K RPM SFF HDD (4K sector size format)	SAS	900 GB
UCS-HD900G10K12G	900 GB 12G SAS 10K RPM SFF HDD	SAS	900 GB
UCS-HD900G15K12G	900 GB 12G SAS 15K RPM SFF HDD	SAS	900 GB
UCS-HD600G10K12G	600 GB 12G SAS 10K RPM SFF HDD	SAS	600 GB
UCS-HD300G10K12G	300 GB 12G SAS 10K RPM SFF HDD	SAS	300 GB
SSDs			
12 Gbps Drives			
UCS-SD16TB12S4-EP	1.6 TB 2.5 inch Enterprise Performance 12G SAS SSD (10X endurance)	SAS	1.6 TB

Table 11 Available Hot-Pluggable Sled-Mounted HDDs and SSDs (continued)

Product ID (PID)	PID Description	Drive Type	Capacity
UCS-SD400G12S4-EP	400 GB 2.5 inch Enterprise Performance 12G SAS SSD (10X endurance)	SAS	400 GB
UCS-SD800G12S4-EP	800 GB 2.5 inch Enterprise Performance 12G SAS SSD (10X endurance)	SAS	800 GB
6 Gbps Drives			
UCS-SD800G12S3-EP	800 GB 2.5 inch Enterprise performance 6G SATA SSD (3 FWPD)	SATA	800 GB
UCS-SD480G12S3-EP	480 GB 2.5 inch Enterprise Performance 6GSATA SSD (3X endurance)	SATA	480 GB
UCS-SD200G12S3-EP	200 GB 2.5 inch Enterprise performance 6G SATA SSD (3 FWPD)	SATA	200 GB
UCS-SD38TBKS4-EV	3.8TB 2.5 inch Enterprise Value 6G SATA SSD (Samsung 863)	SATA	3.8 TB
UCS-SD16TB12S3-EP	1.6 TB 2.5 inch Enterprise Performance 6G SATA SSD (3X endurance) (Intel 3610)	SATA	1.6 TB
UCS-SD960GBKS4-EV	960 GB 2.5 inch Enterprise Value 6G SATA SSD	SATA	960 GB
UCS-SD400G0KS2-EP ²	400 GB SAS 2.5 inch Enterprise Performance SSD (Samsung 1625)	SAS	400 GB
UCS-SD200G0KS2-EP ²	200 GB SAS 2.5 inch Enterprise Performance SSD (Samsung 1625)	SAS	200 GB
UCS-SD240GBKS4-EV	240 GB 2.5 inch Enterprise Value 6G SATA SSD	SATA	240 GB
UCS-SD16TBKS4-EV	1.6 TB 2.5 inch Enterprise Value 6G SATA SSD (Intel 3510)	SATA	1.6 TB
UCS-SD480GBKS4-EV	480 GB 2.5 inch Enterprise Value 6G SATA SSD (Intel 3510)	SATA	480 GB
UCS-SD120GBKS4-EV	120 GB 2.5 inch Enterprise Value 6G SATA SSD (Intel 3510)	SATA	120 GB
UCS-SD480GBIS6-EV	480GB 2.5 inch Enterprise Value 6G SATA SSD (Intel S4500)	SATA	480 GB
UCS-SD960GBIS6-EV	960GB 2.5 inch Enterprise Value 6G SATA SSD (Intel S4500)	SATA	960 GB
UCS-SD38TBIS6-EV	3.8TB 2.5 inch Enterprise Value 6G SATA SSD (Intel S4500)	SATA	3.8 TB
UCS-SD480GIS3-EP	480GB 2.5in Enterprise performance 6G SATA SSD(3X endurance) (Intel S4600)	SATA	480 GB
UCS-SD960GIS3-EP	960GB 2.5in Enterprise performance 6G SATA SSD(3X endurance) (Intel S4600)	SATA	960 GB
UCS-SD19TIS3-EP	1.9TB 2.5in Enterprise performance 6G SATA SSD(3X endurance) (Intel S4600)	SATA	1.9 TB

Notes . . .

1. UCS Rack Servers require minimum firmware version 2.0(4) to support 4K sector size drives.

Operating Systems supported on 4k sector size drives is as follows:

- Windows: Windows 8 and later and Windows Server 2012 and later
- Linux: RHEL 6.5/6.6/6.7/7.0/7.2/SLES 11 SP3 and SLES 12
- ESXi/VMware is not supported

EFI Mode must be used when booting from 4K sector size drives, legacy mode is not supported.

Ensure that 4K sector size and 512 byte sector size drives are not mixed in the same RAID volume.

Approved Configurations

(1) LSI MegaRAID SAS 9361CV-8i RAID controller

- Select up to 8 SAS or SATA internal drives listed in [Table 11](#). This configuration supports RAID 0, 1, 5, 6, 10, 50, and 60.

(2) Cisco 12G SAS Modular 8-port RAID controller

- Select up to 8 SAS or SATA internal drives listed in [Table 11](#). This configuration supports RAID 0, 1, 5, 10, and 50.

(3) Cisco 12G SAS Modular 12-port RAID controller

- Select up to 12 SAS or SATA internal drives listed in [Table 11](#). This configuration supports RAID 0, 1, 5, 6, 10, 50, and 60.

Caveats

- You can mix SAS/SATA drives. You can also mix HDD and SSD drives, as long as all the HDDs are in the same RAID volume and all the SSDs are in the same RAID volume.
- SSDs and HDDs should not be mixed in the same RAID volume.

Choose SFF 2.5" NVMe SSDs



NOTE: See [Table 15 on page 30](#) for available NVMe/PCIe add-in Cards

The standard SFF 2.5" NVMe SSD drive features are:

- 2.5-inch small form factor
- Hot-swappable
- Sled-mounted
- NVMe-based

The available drives are listed in [Table 12](#).

Table 12 SFF 2.5" NVMe SSDs

Product ID (PID)	PID Description	Drive Type	Capacity
UCS-PCI25-38001	UCS PCIe/NVMe 2.5" SFF Storage 3800 GB (HGST SN100) Read Intensive	NVMe SSD	3.8 TB
UCS-PCI25-16003	UCS PCIe/NVMe 2.5" SFF Storage 1600 GB (Intel P3600) High Endurance	NVMe SSD	1.6 TB
UCS-SDHPCIE16TB	UCS PCIe/NVMe 2.5" Storage 1600 GB (HGST SN100) High Endurance	NVMe SSD	1.6 TB
UCS-SDHPCIE800GB	UCS PCIe/NVMe 2.5" Storage 800 GB (HGST SN100) High Endurance	NVMe SSD	800 GB
UCS-PCI25-80010	UCS PCIe/NVMe 2.5" SFF Storage 800 GB Intel P3700 High Endurance	NVMe SSD	800 GB
UCS-PCI25-8003	UCS PCIe/NVMe 2.5" SFF Storage 800 GB (Intel P3600) High Endurance	NVMe SSD	800 GB
UCS-PCI25-40010	UCS PCIe/NVMe 2.5" SFF Storage 400 GB (Intel P3700) High Endurance	NVMe SSD	400 GB

Caveats

- A maximum of two NVMe SFF 2.5" drives can be ordered.
- NVMe SFF 2.5" drives are bootable only in standalone mode with IMC software and in UEFI mode only.
- NVMe HHHL drives are not bootable.
- NVMe SFF 2.5" drives cannot be controlled with a RAID controller.
- In a two-CPU system, only one NVMe SFF 2.5" drive is supported (in drive bay 5). In a four-CPU system, two NVMe SFF 2.5" drives are supported (in drive bays 5 and 9).

STEP 5 CHOOSE RAID CONFIGURATION

The C460 M4 server accommodates any one of the following RAID controllers for internal drives:

- LSI MegaRAID SAS 9361CV-8i RAID controller
- Cisco 12G SAS Modular 8-port RAID controller
- Cisco 12G SAS Modular 12-port RAID controller

The C460 M4 server accommodates the following HBA for external drives:

- Cisco 9300-8E 12G SAS HBA (supports JBOD only)

The C460 M4 chassis contains a front drive bay housing up to 12 HDDs or SSDs.

Cisco can provide factory-configured RAID 0, 1, 5, 6, and 10 systems depending on the RAID implementation chosen, the RAID controller chosen, and the number of drives ordered. Factory-configured RAID options are listed at the end of [Table 13](#). Note that RAID levels 50 and 60 are supported on the Cisco 12G SAS Modular 12-port RAID controller, but are not factory configurable.

Choose Internal Drive RAID Controller

Choose one internal RAID controller with a desired RAID configuration option from [Table 13](#) and, if desired, one external drive RAID controller.

Table 13 Available Internal Drive RAID Options

Product ID (PID)	PID Description
RAID Controllers	
UCS-RAID9361CV-8I	<p>LSI MegaRAID SAS 9361CV-8i controller (RAID 0, 1, 5, 6, 10, 50, 60 supported)</p> <ul style="list-style-type: none"> ■ Plugs into a dedicated PCIe slot on the server motherboard (see Figure 7 on page 64). ■ Supports from 1 to 8 internal SAS or SATA drives ■ Includes a 1 GB Transportable Memory Module (TMM) and a chassis-mounted (remote) supercapacitor for data cache power backup ■ Factory-configured RAID options: RAID 0, 1, 5, 6, 10 (see the RAID PIDs section in this table) ■ This RAID controller supports only the following drive bays: 3, 4, 6, 7, 8, 10, 11, 12 (see Figure 2 on page 4)

Table 13 Available Internal Drive RAID Options (*continued*)

Product ID (PID)	PID Description												
UCSC-MRAID12G, plus UCSC-MRAID12G-512	<p>Cisco 12G SAS Modular 8-port RAID Controller (JBOD, RAID 0, 1, 5, 10, 50 supported)</p> <ul style="list-style-type: none"> ■ Plugs into a dedicated PCIe slot on the server motherboard (see Figure 7 on page 64). ■ Supports up to 8 internal SAS or SATA drives ■ Factory-configured RAID options: RAID 0, 1, 5, 10 (see the RAID PIDs section in this table) ■ This RAID controller supports only the following drive bays: 3, 4, 6, 7, 8, 10, 11, 12 (see Figure 2 on page 4) <p>Must be ordered with a 512 MB Flash-Backed Write Cache (FBWC), which includes a 512 MB data cache plus a SuperCap for data cache power backup for the Cisco 12G SAS Modular 8-port RAID controller. Supports JBOD, RAID 0, 1, 5, 10, 50.</p> <p>The FBWC PID is UCSC-MRAID12G-512.</p>												
UCSC-MRAIDC460, plus one of the following: <ul style="list-style-type: none"> ■ UCSC-MRAID12G-1GB ■ UCSC-MRAID12G-2GB ■ UCSC-MRAID12G-4GB 	<p>Cisco 12G SAS Modular 12-port RAID controller (JBOD, RAID 0, 1, 5, 6, 10, 50, 60 supported)</p> <ul style="list-style-type: none"> ■ Plugs into a dedicated PCIe slot on the server motherboard (see Figure 7 on page 64). ■ Supports up to 12 internal SAS or SATA drives ■ Must be ordered along with one of the onboard Flash-Backed Write Cache (FBWC) upgrade options shown in the table below <table border="1" data-bbox="506 1083 1422 1306"> <thead> <tr> <th>RAID Card Version</th> <th>Supported RAID Levels</th> <th>Onboard FBWC</th> </tr> </thead> <tbody> <tr> <td>UCSC-MRAID12G-1GB</td> <td>JBOD, 0, 1, 5, 6, 10, 50, 60</td> <td>1 GB</td> </tr> <tr> <td>UCSC-MRAID12G-2GB</td> <td>JBOD, 0, 1, 5, 6, 10, 50, 60</td> <td>2 GB</td> </tr> <tr> <td>UCSC-MRAID12G-4GB</td> <td>JBOD, 0, 1, 5, 6, 10, 50, 60</td> <td>4 GB</td> </tr> </tbody> </table> <ul style="list-style-type: none"> ■ Factory-configured RAID options: RAID 0, 1, 5, 6, 10 (see the RAID PIDs section in this table) 	RAID Card Version	Supported RAID Levels	Onboard FBWC	UCSC-MRAID12G-1GB	JBOD, 0, 1, 5, 6, 10, 50, 60	1 GB	UCSC-MRAID12G-2GB	JBOD, 0, 1, 5, 6, 10, 50, 60	2 GB	UCSC-MRAID12G-4GB	JBOD, 0, 1, 5, 6, 10, 50, 60	4 GB
RAID Card Version	Supported RAID Levels	Onboard FBWC											
UCSC-MRAID12G-1GB	JBOD, 0, 1, 5, 6, 10, 50, 60	1 GB											
UCSC-MRAID12G-2GB	JBOD, 0, 1, 5, 6, 10, 50, 60	2 GB											
UCSC-MRAID12G-4GB	JBOD, 0, 1, 5, 6, 10, 50, 60	4 GB											
UCSC-SAS9300-8E	<p>LSI MegaRAID SAS 9300-8E external drive controller</p> <ul style="list-style-type: none"> ■ 12 Gb/s ■ JBOD support ■ Plugs into any rear panel PCIe slot ■ Supports up to 1024 external devices 												

Table 13 Available Internal Drive RAID Options (*continued*)

Product ID (PID)	PID Description
RAID Configuration	
R2XX-RAID0	Factory pre-configured RAID striping option Enable RAID 0 Setting. Requires a minimum of 1 hard drive.
R2XX-RAID1	Factory pre-configured RAID mirroring option Enable RAID 1 Setting. Requires exactly 2 drives, with same size, speed, capacity.
R2XX-RAID5	Factory pre-configured RAID option Enable RAID 5 Setting. Requires minimum 3 drives of same size, speed, capacity.
R2XX-RAID6	Factory pre-configured RAID option Enable RAID 6 Setting. Requires minimum 4 drives of same size, speed, capacity.
R2XX-RAID10	Factory pre-configured RAID option Enable RAID 10 Setting. Requires an even number of drives (minimum 4 drives) of same size, speed, capacity.



NOTE: No RAID option can be chosen if you have one of the following configurations:

- A mix of SAS and SATA drives
- No drives

Choose External Drive Controller

If desired, choose one internal drive controller from [Table 13](#) and, if desired, one external drive RAID controller

Table 14 Available External Drive Controller RAID Options

Product ID (PID)	PID Description
SAS HBA for External JBOD Attach	
Note that the following controller, if selected, is installed by default in PCIe slot 5 (riser 1). Two SFF8644 mini-SAS x4 connectors on this card are accessible at the rear of the chassis.	
UCSC-SAS9300-8E	Cisco 12G SAS 9300-8e HBA for external JBOD attach <ul style="list-style-type: none"> ■ Supports external JBOD using x4 and x8 wide SAS ports
<div style="border: 1px solid black; padding: 10px;"> <div style="display: flex; align-items: flex-start;">  <div> <p>NOTE: For Cisco 12G SAS 9300-8e HBA external drive enclosure support, see the enclosure section of the compatibility list at the following link:</p> <p>http://tinyurl.com/pp83xyk</p> <p>Customers should contact their storage vendor for technical support related to external JBOD enclosures.</p> </div> </div> </div>	

Approved Configurations

(1) One RAID controller card for internal drives

- Choose the 9361CV-8i, Cisco 12G SAS Modular 8-port, or Cisco 12G SAS Modular 12-port RAID controller listed in [Table 13](#). You will be able to control from 1 to 8 drives with the 9361CV-8i and Cisco 12G SAS Modular 8-port RAID controllers and up to 12 drives with the Cisco 12G SAS Modular 12-port RAID controller.

(2) One controller card for external drives

- Choose the Cisco 12G SAS 9300-8e HBA for external JBOD attach listed in [Table 14](#). You will be able to control an external JBOD chassis of drives.

(3) One RAID controller card for internal drives and one controller card for external drives

- Choose the 9361CV-8i, Cisco 12G SAS Modular 8-port, or Cisco 12G SAS Modular 12-port RAID controller listed in [Table 13](#). In addition, choose the Cisco 12G SAS 9300-8e HBA for external JBOD attach listed in [Table 14](#).

Caveats

- You can choose only one internal drive RAID controller.
- You can choose one internal drive RAID controller in combination with one external drive controller if desired.
- You can choose an optional RAID configuration for the internal drive RAID controller (RAID 0, 1, 5, 6, or 10), which is pre-configured at the factory. If you do not choose a RAID configuration, the disks will be configured as a JBOD.
- If you order the Cisco 12G SAS Modular 8-port RAID Controller, you must also order the 512 MB FBWC. The FBWC PID is UCSC-MRAID12G-512.
- If you order the Cisco 12G SAS Modular 12-port RAID Controller, you must also order one FBWC (either 1 GB, 2GB, or 4GB).
- Avoid plugging the LSI MegaRAID 9300-8e external drive RAID controller into rear panel PCIe slot 3, which is x4 and has limited bandwidth.
- The LSI MegaRAID SAS 9361CV-8i controller cannot be selected along with v3 CPUs or DDR4 memory PIDs.

STEP 6 CHOOSE PCIe OPTION CARD(S)

The standard PCIe card offerings are:

- Converged Network Adapters (CNA)
- Network Interface Cards (NICs)
- Host Bus Adapters (HBAs)
- UCS Storage Accelerators

Choose PCIe Option Cards

The available PCIe option cards are listed in [Table 15](#).

Table 15 Available PCIe Option Cards

Product ID (PID)	PID Description	Card Height
Converged Network Adapters (CNA)		
UCSC-PCIE-C10T-02	Cisco VIC 1225T Dual Port 10GBaseT CNA	Half
UCSC-PCIE-C40Q-02	Cisco VIC 1285 Dual Port 40Gb QSFP CNA	Half
UCSC-PCIE-CSC-02 ¹	Cisco VIC 1225 Dual Port 10Gb SFP+ CNA	Half
UCSC-PCIE-C40Q-03	Cisco VIC 1385 Dual Port 40Gb QSFP+ CNA w/RDMA	Half
UCSC-PCIE-Q8362	QLogic QLE8362 dual-port 10 GbE FCoE CNA	Half
UCSC-PCIE-E14102	Emulex OCe14102-FX dual-port 10 GbE FCoE CNA	Half
UCSC-PCIE-E14102B	Emulex OCe14102B-UX dual-port 10G SFP+ with iSCSI, FCoE CNA	Half
Network Interface Cards (NICs)		
N2XX-ABPCI03-M3	Broadcom 5709 Quad Port 1Gb w/TOE iSCSI for M3 Servers	Half
N2XX-AIPCI01 ²	Intel X520 Dual Port 10Gb SFP+ Adapter	Half
UCSC-PCIE-B3SFP	Broadcom 57810 10Gb AFEX SFP+	Half
UCSC-PCIE-IRJ45	Intel i350 Quad Port 1Gb Adapter	Half
UCSC-PCIE-ITG ¹	Intel X540 Dual Port 10GBase-T Adapter	Half
UCSC-PCIE-QNICBT	QLogic QLE8442 dual-port 10Gbase-T NIC	Half
UCSC-PCIE-QNICSFP	QLogic QLE8442 dual-port 10G SFP+ NIC	Half
UCSC-PCIE-QNICBT	QLogic 10Gb NIC 10GbaseT 57840 iSCSI, TOE & SRIOV	Half
UCSC-PCIE-QNICSFP	QLogic 10Gb NIC SFP+ 57840 iSCSI, TOE & SRIOV	Half
UCSC-PCIE-ID10GC	Intel X550-T2 dual-port 10GBase-T NIC	Half
UCSC-PCIE-ID10GF	Intel X710-DA2 dual-port 10G SFP+ NIC	Half
UCSC-PCIE-IQ10GF	Intel X710 quad-port 10G SFP+ NIC	Half
UCSC-PCIE-ID40GF	Intel XL710 dual-port 40G QSFP+ NIC	Half

Table 15 Available PCIe Option Cards (*continued*)

Product ID (PID)	PID Description	Card Height
Host Bus Adapters (HBAs)		
UCSC-PCIE-BS32GF	Broadcom LPe32000 Single-Port 32G FC HBA	Half
UCSC-PCIE-BD32GF	Broadcom LPe32002 Dual-Port 32G FC HBA	Half
UCSC-PCIE-QD32GF	Qlogic QLE2742 dual-port 32G FC HBA	Half
N2XX-AEPCI03	Emulex LPe 11002 Dual Port 4Gb Fibre Channel HBA	Half
N2XX-AEPCI05	Emulex LPe 12002 Dual Port 8Gb Fibre Channel HBA	Half
UCSC-PCIE-E16002	Emulex Lpe 16002-M6, 16Gb Dual Port Fibre Channel HBA with SR Optics	Half
N2XX-AQPCI05	Qlogic QLE2562 Dual Port 8Gb Fibre Channel HBA	Half
UCSC-PCIE-Q2672	Qlogic QLE2672-CSC, 16Gb Dual Port Fibre Channel HBA with SR Optics	Half
UCS Storage Accelerators³		
UCSC-F-S64002	UCS Rack PCIe Storage 6400 GB SanDisk SX350 Medium Endurance	Half
UCSC-F-S32002	UCS Rack PCIe Storage 3200 GB SanDisk SX350 Medium Endurance	Half
UCSC-F-S16002	UCS Rack PCIe Storage 1600 GB SanDisk SX350 Medium Endurance	Half
UCSC-F-S13002	UCS Rack PCIe Storage 1300 GB SanDisk SX350 Medium Endurance	Half
UCSC-F-FIO-1000PS	UCS 1000 GB Fusion ioMemory3 PX Performance line for Rack M4	Half
UCSC-F-FIO-1300PS	UCS 1300 GB Fusion ioMemory3 PX Performance line for Rack M4	Half
UCSC-F-FIO-2600PS	UCS 2600 GB Fusion ioMemory3 PX Performance line for Rack M4	Half
UCSC-F-FIO-5200PS	UCS 5200 GB Fusion ioMemory3 PX Performance line for Rack M4	Full
UCS NVMe/PCIe Add in Cards		
UCSC-F-H38001	3.8 TB NVMe/PCIe storage (HGST SN150) Read Intensive	Half
UCSC-F-I20003	2.0 TB NVMe/PCIe storage (Intel P3600) High Endurance	Half
UCSC-F-H19001	1.9 TB NVMe/PCIe storage (HGST SN150) Read Intensive	Half
UCSC-F-I160010	1.6 TB NVMe/PCIe storage (Intel P3700) High Endurance	Half
UCSC-F-I12003	1.2 TB NVMe/PCIe storage (Intel P3600) High Endurance	Half
UCSC-F-I80010	800 GB NVMe/PCIe storage (Intel P3700) High Endurance	Half

Notes . . .

1. The UCSC-PCIE-ITG and UCSC-PCIE-CSC-02 cannot be installed in the same system.
2. The Intel X520 supports the following Cisco PIDs: CDE2-SFP-1WLR and CDE2-SFP-1WSR SFPs. Refer to the Intel X520 product brief for a full list of supported optics and cables.
3. Do not mix Fusion io storage accelerator families. That is, do not mix “PS” or “SS” (ioMemory3) with “M” (ioDrive2) family cards.

Approved Configurations

- (1) Select up to 10 PCIe Cards

- Use [Table 16](#) and [Table 17 on page 32](#) as a guide for adding PCIe cards. See [Figure 5](#) for the slot locations.

Table 16 PCIe Expansion Slot Numbering

Slot Number	Slot Characteristics
1	CPU1 controlled, PCIe Gen 3, x8 lanes, full-length card, x8 connector
2	CPU1 controlled, PCIe Gen 3, x16 lanes, NCSI, full-length card, x16 connector
3	CPU2 controlled, PCIe Gen 3, x4 lanes, NCSI, 3/4-length card, x16 connector
4 ¹	CPU2 controlled, PCIe Gen 3, x8 lanes, NCSI, 3/4-length card, x16 connector
5 ¹	CPU2 controlled, PCIe Gen 3, x8 lanes, NCSI, 1/2-length card, x16 connector
6	CPU4 controlled, PCIe Gen 3, x8 lanes, full-length card, x8 connector
7	CPU3 controlled, PCIe Gen 3, x16 lanes, NCSI, full-length card, x16 connector
8	CPU4 controlled, PCIe Gen 3, x8 lanes, NCSI, 3/4-length card, x16 connector
9 ¹	CPU3 controlled, PCIe Gen 3, x16 lanes, NCSI, 3/4-length card, x16 connector
10 ¹	CPU4 controlled, PCIe Gen 3, x8 lanes, 1/2-length card, x16 connector

Notes . . .

1. Slots 4, 5, 9 and 10 can be enabled for 12-volt VIC standby power (only one at a time).

Table 17 PCIe Expansion Slot Priorities

PCIe Card Type	Primary Slots (install here first, top to bottom order)	Secondary Slot (install here second, top to bottom order)	Alternate Slots (install top to bottom order; may have reduced functionality)
LSI MegaRAID Card	Internal RAID slot (see Figure 7 on page 64)	—	—
Low-profile x8 Network Card or RAID card for external drives	Slot 5 (riser 1) Slot 10 (riser 2)	Slot 8 (riser 2) Slot 9 (riser 2) Slot 2 (riser 1) Slot 7 (riser 2) Slot 1 (riser 1) Slot 6 (riser 2)	Slot 3 (Riser 1) Slot 4 (riser 1)
VIC cards	Slot 4 (Riser 1) ¹ Slot 9 (riser 2)	Slot 5 (riser 1) Slot 10 (riser 2)	Slot 2 (riser 1) Slot 7 (riser 2) Slot 3 (riser 1) Slot 8 (riser 2)
GPU ²	Slots 7 and 6 (riser 2) Slots 2 and 1 (riser 1)	—	—

Table 17 PCIe Expansion Slot Priorities (continued)

PCIe Card Type	Primary Slots (install here first, top to bottom order)	Secondary Slot (install here second, top to bottom order)	Alternate Slots (install top to bottom order; may have reduced functionality)
UCS Storage Accelerators ³			
Fusion ioDrive2	Slot 8 (riser 2) Slot 2 (riser 1)	Slot 7 (riser 2) Slot 6 (riser 2) Slot 1 (riser 1) Slot 9 and 10 (riser 2) Slot 5 (riser 1)	Slot 3 (riser 1) ⁴ Slot 4 (riser 1)
Fusion ioMemory3	Slot 8 (riser 2) Slot 2 (riser 1)	Slot 7 (riser 2) Slot 6 (riser 2) Slot 1 (riser 1) Slot 9 and 10 (riser 2) Slot 5 (riser 1)	Slot 3 (riser 1) ¹ Slot 4 (riser 1)

Notes . . .

1. Primary slots for UCS Integration and Cisco card NIC mode
2. You cannot have a GPU installed in slot 7 and at the same time have a QLE2562 HBA (N2XX-AQPCI05) installed in slot 9.
3. Fusion ioDrive2 and Fusion ioMemory3 storage accelerators cannot be mixed.
4. This slot is a x4 slot, so there is some performance degradation when installing a storage accelerator in this slot.

Figure 5 PCIe Slot Locations

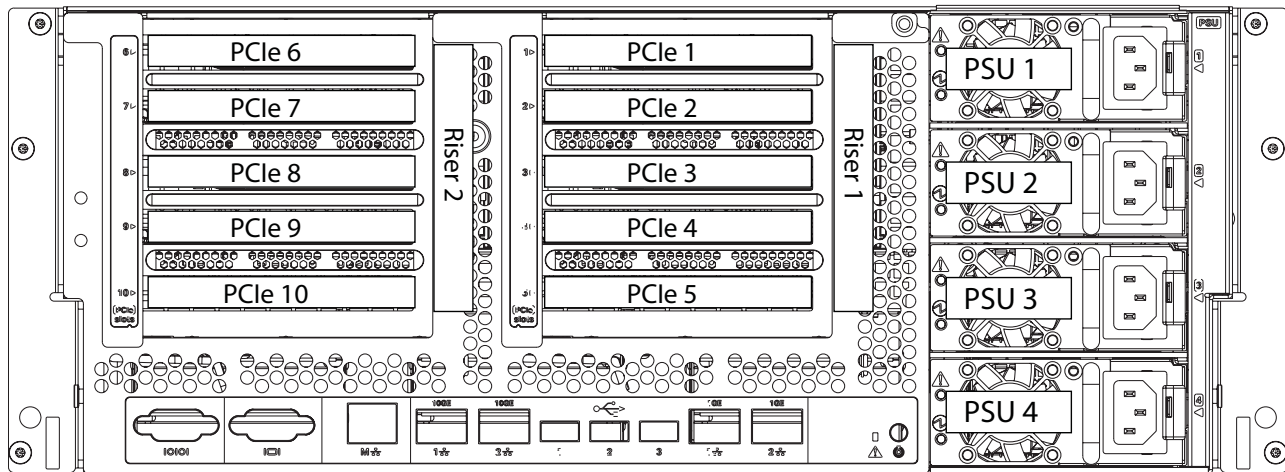

Caveats

- CPU1 and CPU2 must be installed to support PCIe slots 1 through 5.
- CPU3 and CPU4 must be installed to support PCIe slots 6 through 10.
- Legacy I/O devices such as video cards are only supported on slots 1, 2, 4, 5, 6, 7, 8, 9, and 10.
- The Cisco Card NIC mode is currently supported only with a Cisco VIC card that is installed in PCIe slot 4, 5, 9, or 10.
- The C460 M4 server accommodates the Cisco Virtual Interface card, which is supported primarily in slot 4.
 - Only one Cisco 1225 VIC can be used for both UCSM management and data traffic in the C460 M4 server
 - The Cisco 1225 VIC in slot 4 handles management and data traffic.
 - If a second Cisco 1225 VIC is installed in slot 5, 9, or 10 it will be used for data traffic only.
 - Only four VICs total are supported in UCSM mode
 - Eight VICs are supported in non-UCSM (CIMC) mode
- All PCIe slots are standard-height and require a standard-height mounting bracket on the PCIe card.
- The UCSC-PCIE-ITG and UCSC-PCIE-CSC-02 cannot be installed in the same system.
- You cannot have a GPU installed in slot 7 and at the same time have a QLE2562 HBA (N2XX-AQPCI05) installed in slot 9.
- Additional considerations for the Cisco 1225 VIC card:
 - Supports 10G SFP+ optical and copper twinax connections
 - To use the Cisco Card NIC mode, this card must be installed in PCIe slot 4, 5, 9, or 10. Slot 4, 5, 9, or 10 can operate while the server is in standby power mode.
 - Requires that the server has CIMC firmware version 1.4(6) or later installed. There is a heartbeat LED on the top of the card that indicates when firmware is active.
 - To use this card for UCS integration (Cisco UCS Manager mode) with Cisco UCS Manager 2.1(0) or later, the minimum card-firmware and uboot image level is 2.1(0.306).
- To help ensure that your operating system is compatible with the cards you have selected, please check the Hardware Compatibility List at this URL:

http://www.cisco.com/en/US/products/ps10477/prod_technical_reference_list.html

STEP 7 CHOOSE PCIe RISERS

Each PCIe riser plugs into the motherboard and contains 5 PCIe slots

Select PCIe Risers

The available PCIe riser options are listed in [Table 18](#).

Table 18 Available PCIe Risers

Product ID (PID)	PID Description
UCSC-PCIE-RSR-05	Riser card with 5 PCIe slots

Approved Configurations

(1) 2-CPU systems

- Order 1 riser card.

(2) 4-CPU systems

- Order 1 or 2 riser cards, depending on how many PCIe cards you need to support.



NOTE: Be sure to take into account that each GPU card installed occupies two adjacent PCIe slots. See [ORDER GPU CARDS and ACCESSORIES \(OPTIONAL\)](#) on page 47 for more details.

STEP 8 ORDER OPTIONAL NETWORK CARD ACCESSORIES

Copper twinax cables and SFP optical modules may be ordered to support the two-port network cards that are available with the server.

Choose Optional Twinax Cables

[Table 19](#) lists the copper twinax cables available for the PCIe cards. You can choose cable lengths of 1, 3, 5, 7, or 10 meters. The two longer cables (7 and 10 meters) are active, which means that they contain active components within the SFP+ housing to improve signal quality.

Table 19 Available Twinax Cables

Product ID (PID)	PID Description
SFP-H10GB-CU1M	10GBASE-CU SFP+ Cable (1 M)
SFP-H10GB-CU3M	10GBASE-CU SFP+ Cable (3 M)
SFP-H10GB-CU5M	10GBASE-CU SFP+ Cable (5 M)

Approved Configurations

(1) Choose Up to Two Twinax Cables for Each Network Card Ordered

- You may choose one or two twinax cables for each compatible PCIe network card ordered. The cables can be different lengths; however, you would normally order two cables of equal lengths to connect to the primary and redundant network switching equipment.

Choose Optional SFP Modules

Optical Cisco SFP+ modules are listed in [Table 20](#).

Table 20 Available SFP Modules

Product ID (PID)	PID Description
SFP-10G-SR	10GBASE-SR SFP+ Module 850 nm, multimode, SR, 3.3V, LC connector, with Digital Optical Monitoring
SFP-10G-LR	10GBASE-LR SFP+ Module 1310 nm, single mode, LR, 3.3 V, with Digital Optical Monitoring
DS-SFP-FC8G-SW	8 Gbit SFP+ Module 850 nm, multimode, SR, 3.3V, LC connector, with Digital Optical Monitoring



NOTE: The Intel X520 NIC supports the following Cisco PIDs: CDE2-SFP-1WLR and CDE2-SFP-1WSR SFPs. Refer to the Intel X520 product brief for a full list of supported optics and cables.

Approved Configurations

(1) Choose Up to Two SFP+ Modules for Each Network Card Ordered

- You may choose one or two SFP+ optical modules cables for each compatible PCIe network card ordered. You would normally order two modules for connecting to the primary and redundant network switching equipment. With the SFP+ optical modules, you can use common fiber optic cables, widely available.

See the [Figure 6 on page 40](#) for typical SFP+ and twinax connections to the network cards.

Caveats

Check the table on the following page for compatibility between the PCIe network cards and SFPs or twinax cables.



NOTE: The table shows all PCIe network cards for all C-series servers. Not all of the cards shown in the table are supported in this server. The intent of the table is to show compatibility between cards and twinax cables or SFPs.

Table 21 PCIe Card Compatibility

PCIe Cards	Twinax Cables	Cisco SFP Modules		
		SFP-10G-SR	SFP-10G-LR	DS-SFP-FC8G-SW
Converged Network Adapters (CNAs)				
UCSC-PCIE-BSFP (Broadcom 57712 Dual Port 10Gb SFP+ w/TOE iSCSI)	Yes	Yes	No	
UCSC-PCIE-CSC-02 (Cisco VIC 1225 Dual Port 10Gb SFP+ CNA)	Yes	Yes	Yes	No
UCSC-PCIE-C10T-02 (Cisco VIC 1225T Dual Port 10GBaseT CNA)	No	No	No	No
UCSC-MLOM-CSC-02 (Cisco UCS VIC1227 VIC MLOM - Dual Port 10Gb SFP+)	Yes	Yes	Yes	No
UCSC-MLOM-C10T-02 (Cisco UCS VIC1227T VIC MLOM - Dual Port 10GBaseT)	No	No	No	No
UCSC-PCIE-C40Q-02 (Cisco VIC 1285 Dual Port 40Gb QSFP CNA)	Yes	No ¹	No	
UCSC-PCIE-C40Q-03 (Cisco VIC 1385 Dual Port 40Gb QSFP+ CNA w/RDMA)	Yes	No ¹	No	
UCSC-PCIE-ESFP (Emulex OCe11102-FX dual-port 10 GbE FCoE CNA (Gen 3 CNA))	Yes	Yes	No	
UCSC-PCIE-QSFP (QLogic QLE8242-CU dual-port 10 GbE FCoE CNA)	Yes	Use Qlogic SFP		
UCSC-PCIE-B3SFP (Broadcom 57810 10Gb A-FEX SFP+)	Yes	Yes	No	
UCSC-PCIE-Q8362 (Qlogic QLE8362 dual-port 10 GbE FCoE CNA)	Yes	Use Qlogic SFP		
UCSC-PCIE-E14102 (Emulex OCe14102-UX dual-port 10 GbE FCoE CNA)	Yes	Yes	No	
Network Interface Cards (NICs)				
N2XX-ABPCI01-M3 (Broadcom 5709 Dual-Port Ethernet PCIe Adapter for M3 Servers)	Use RJ45 Ethernet cable			
N2XX-ABPCI03-M3 (Broadcom 5709 Quad Port 10/100/1Gb NIC w/TOE iSCSI for M3 Servers)	Use RJ45 Ethernet cable			
N2XX-AIPCI01 (Intel X520 Dual Port 10Gb SFP+ Adapter)	Yes	Use Intel SFP CDE2-SFP-1WLR or CDE2-SFP-1WSR		
UCSC-PCIE-ITG (Intel X540 Dual Port 10GBase-T Adapter)	Use RJ45 Ethernet cable			
UCSC-PCIE-IRJ45 (Intel i350 Quad Port 1Gb Adapter)	Use RJ45 Ethernet cable			

Table 21 PCIe Card Compatibility (*continued*)

PCIe Cards	Twinax Cables	Cisco SFP Modules		
		SFP-10G-SR	SFP-10G-LR	DS-SFP-FC8G-SW
UCSC-PCIE-BTG (Broadcom 57712 Dual Port 10GBASE-T w/TOE iSCSI)	Yes	No	No	
Host Bus Adapters (HBAs)				
N2XX-AEPCI03 (Emulex LPe 11002 Dual Port 4Gb Fibre Channel HBA)	No	Preinstalled - do not change SFP		
N2XX-AEPCI05 (Emulex LPe 12002 Dual Port 8Gb Fibre Channel HBA)	No	Preinstalled - do not change SFP		
N2XX-AQPCI03 (QLogic QLE2462 Dual Port 4Gb Fibre Channel HBA)	No	Preinstalled - do not change SFP		
N2XX-AQPCI05 (QLogic QLE2562 Dual Port 8Gb Fibre Channel HBA)	No	Preinstalled - do not change SFP		
UCSC-PCIE-Q2672 (QLogic QLE2672-CSC, 16Gb Fibre Channel HBA with SR Optics)	No	Preinstalled - do not change SFP		
UCSC-PCIE-E16002 (Emulex LPe16002-M6, 16Gb Fibre Channel HBA with SR Optics)	No	Preinstalled - do not change SFP		

Notes . . .

1. This card supports a 4x10 Gbps QSFP to SFP breakout fiber cable.

Figure 6 Network Card Connections

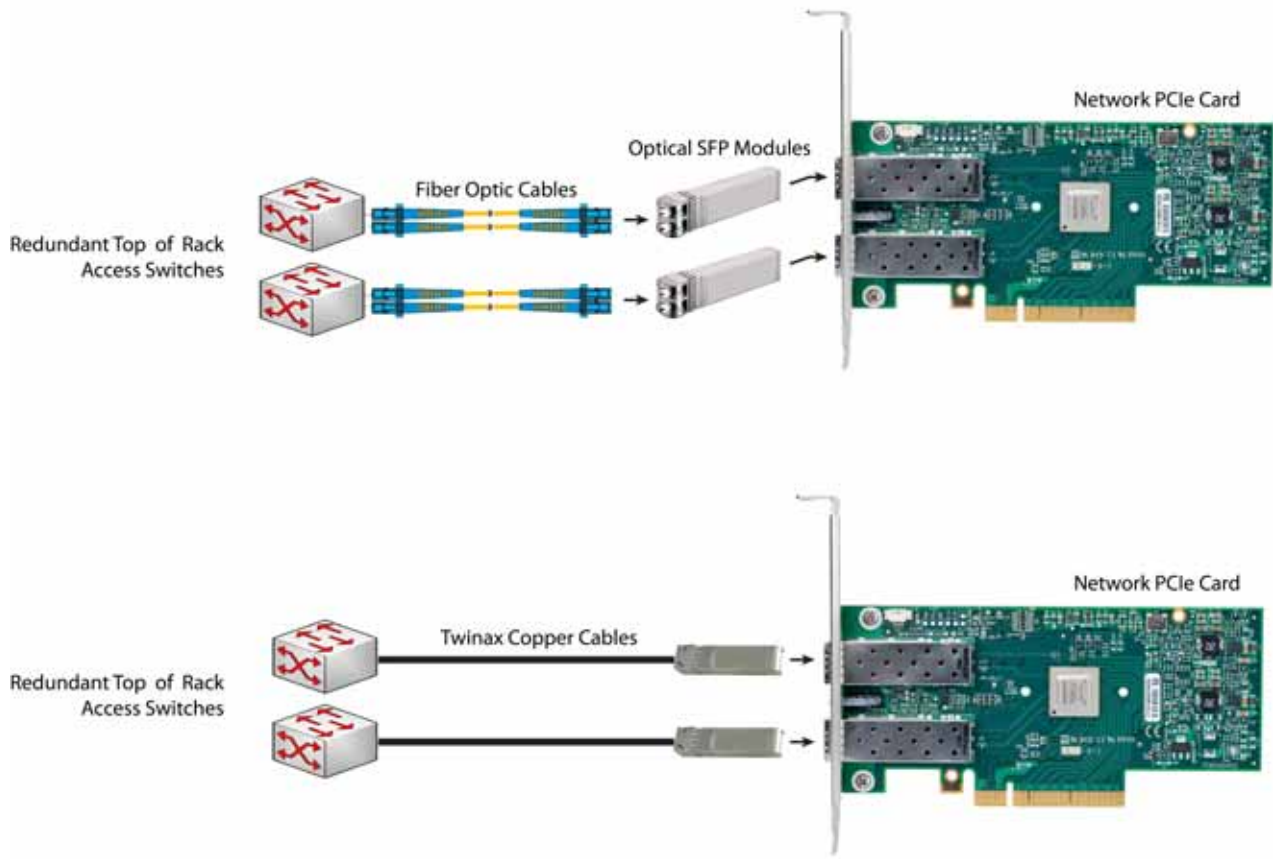

STEP 9 ORDER GPU CARDS and ACCESSORIES (OPTIONAL)

The GPU offerings are:

- GPU PCIe cards
- GPU power cables

Select GPU Options

The available GPU PCIe options are listed in [Table 22](#).

Table 22 Available PCIe Option Cards

Product ID (PID)	PID Description	Card Size
GPU PCIe Cards		
UCSC-GPU-P100-16G	NVIDIA P100 16GB	Full-height, double wide
UCSC-GPU-P100-12G	NVIDIA P100 12GB	Full-height, double wide
UCSC-GPU-7150X2	AMD Firepro 7150x2	Full-height, double wide
UCSC-GPU-VGXXK2	NVIDIA GRID K2	Full-height, double wide
UCSC-GPU-K10	NVIDIA K10	Full-height, double wide
UCSC-GPU-K20	NVIDIA K20	Full-height, double wide
UCSC-GPU-K20X	NVIDIA K20X	Full-height, double wide
UCSC-GPU-K40	NVIDIA K40	Full-height, double wide
UCSC-GPU-K80	NVIDIA K80	Full-height, double wide
UCSC-GPU-M10 ¹	NVIDIA M10	Full-height, double wide
UCSC-GPU-M60	NVIDIA M60	Full-height, double wide
GPU Individual Power Cable for VGXX1/VGXX2/K10/K20/K20X/K40 GPUs		
UCSC-AUXCBL8-EX	PCIe auxiliary power cable kit with adapter cable and 8-pin	
GPU Individual Power Cable for M60/K80/AMD Firepro GPUs		
UCSC-300W-460M4	300 Watt Cable for UCS C460M4 Rack Server	

Notes . . .

1. A power cable is not included with the M10. When ordering an M10, you must to purchase a power cable (UCSC-GPUCBL-240M4=) for the GPU.

Approved Configurations

(1) GPU Power Cables

- You must order one power cable (UCSC-AUXCBL8-EX) for each VGXK1/VGXK2/K10/K20/K20X/K40 GPU you order. One end of the power cable plugs into the GPU and the other end into the PCIe riser power connector that is located close to the GPU.
- You must order one power cable (UCSC-300W-460M4) for each M10/M60/K80/AMD Firepro GPU you order. One end of the power cable plugs into the GPU and the other end into the PCIe riser power connector that is located close to the GPU.

(2) NVIDIA GPU Slot Population Rules



NOTE: A 2-CPU configuration can have 1 GPU maximum and a 4-CPU configuration can have up to 2 GPUs. Any configuration that includes a GPU requires four 1400 W power supplies in the server.

Caveats

- NVIDIA GRID K1 and K2 GPUs can be mixed. No other GPU mixing is allowed.
- You cannot mix the K80 with any other GPU
- You must order one power cable for each GPU you order. The power cable plugs into the motherboard GPU power connector and to the appropriate GPU(s).
- Slot 7 is the preferred slot for the first GPU.



NOTE: An 8-pin power connector for the GPU is located on each PCIe riser. Connect a cable as appropriate from this connector to the power connector on the GPU.

- You cannot have a GPU installed in slot 7 and at the same time have a QLE2562 HBA (N2XX-AQPCI05) installed in slot 9.
- Systems with 64 GB DIMMs cannot implement any GPUs. Please note, this limitation does not apply to Pascal series GPU (P100)

STEP 10 ORDER POWER SUPPLIES

The available power supplies are listed in [Table 23](#).

Table 23 Power Supplies

Product ID (PID)	PID Description
UCSC-PSU2V2-1200W ¹	1200W/800W V2 AC Power Supply for 2U C-Series Servers
UCSC-PSU2V2-1400W	1400W AC Power Supply (200 - 240V) 2U & 4U C Series Servers

Notes . . .

1. The power output is 1200W with a 200-240V input and 800W with a 100-120V input.

Caveats

- If you select the UCSC-PSU2V2-1200W: you must select four of these power supplies. You cannot select any GPUs when you use these power supplies.
- For the UCSC-PSU2V2-1400W: if there are 2 CPUs and 0 GPUs and the quantity of 64 GB DIMMs is less than or equal to 32, either two or four of these power supplies can be configured; otherwise, four power supplies are required.

STEP 11 SELECT AC POWER CORD(S)

Select the appropriate AC power cords listed in [Table 24](#). You may select a minimum of no power cords and a maximum of two power cords. If you select the option R2XX-DMYMPWRCORD, no power cord is shipped with the server.

Table 24 Available Power Cords

Product ID (PID)	PID Description	Images
R2XX-DMYMPWRCORD	No power cord (dummy PID to allow for a no power cord option)	Not applicable
CAB-N5K6A-NA	Power Cord, 200/240V 6A, North America	
CAB-C13-C14-2M	CABASY,WIRE,JUMPER CORD, PWR, 2 Meter, C13/C14,10A/250V	
CAB-C13-C14-2M-JP	Power Cord C13-C14, 2M/6.5ft Japan PSE mark	
CAB-C19-C20-3M-JP	Power Cord C19-C20, 3M/10ft Japan PSE mark	
CAB-250V-10A-AR	Power Cord, SFS, 250V, 10A, Argentina	
CAB-9K10A-AU	Power Cord, 250VAC 10A 3112 Plug, Australia	
CAB-250V-10A-CN	AC Power Cord - 250V, 10A - PRC	

Table 24 Available Power Cords

Product ID (PID)	PID Description	Images
CAB-9K10A-EU	Power Cord, 250VAC 10A CEE 7/7 Plug, EU	<p>Plug: M2511 Cordset rating: 10A/16 A, 250 V Length: 8 ft 2 in. (2.5 m) Connector: VSCC15</p>
CAB-250V-10A-ID	Power Cord, SFS, 250V, 10A, India	<p>Plug: EL 208 Cordset rating 16A, 250V (2500mm) Connector: EL 701</p>
CAB-250V-10A-IS	Power Cord, SFS, 250V, 10A, Israel	<p>Plug: EL 212 (SI-32) Cordset rating 10A, 250V/500V MAX (2500 mm) Connector: EL 701B (IEC60320/C13)</p>
CAB-9K10A-IT	Power Cord, 250VAC 10A CEI 23-16/VII Plug, Italy	<p>Plug: I2C3 (CEI 23-16) Cordset rating: 10 A, 250 V Length: 8 ft 2 in. (2.5 m) Connector: C15M (EN60320/C15)</p>
CAB-9K10A-SW	Power Cord, 250VAC 10A MP232 Plug, Switzerland	<p>Plug: MP232-R Cordset rating: 10 A, 250 V Length: 8 ft. 2 in (2.5 m) Connector: IEC 60320 C15</p>
CAB-9K10A-UK	Power Cord, 250VAC 10A BS1363 Plug (13 A fuse), UK	<p>Plug: EL 210 (BS 1363A) 13 AMP fuse Cordset rating: 10 A, 250 V/500 V MAX Length: 2500mm Connector: EL 701C (EN 60320/C15)</p>
CAB-9K12A-NA	Power Cord, 125VAC 13A NEMA 5-15 Plug, North America	
CAB-AC-L620-C13	AC Power Cord, NEMA L6-20 - C13, 2M/6.5ft	

Table 24 Available Power Cords

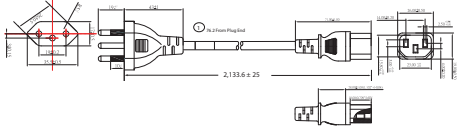
Product ID (PID)	PID Description	Images
CAB-250V-10A-BR	Power Cord - 250V, 10A - Brazil	 <p>The image shows a technical drawing of a power cord. It includes a perspective view of the cord with a red crosshair indicating the center of the plug. A side view shows the plug with dimensions: 1.125 ± 0.05 for the plug width, 1.125 ± 0.05 for the plug height, and 2.122 ± 0.25 for the total length of the cord. A detail view of the plug shows the internal contacts and the text '75.21mm Plug/End'. A small photograph of the physical power cord is shown at the bottom right of the drawing.</p>

STEP 12 ORDER OPTIONAL SLIDE RAIL KIT

You can order the slide rail kit listed in [Table 25](#).

Table 25 Slide Rail Kits

Product ID (PID)	PID Description
UCSC-RAIL-4U	Rail Kit for UCS C460 M4

STEP 13 ORDER OPTIONAL CABLE MANAGEMENT ARM

A cable management arm is available for the tool-less slide rail kit (PID UCSC-RAIL-4U). The cable management arm attaches to the left and right slide rails at the rear of the server and is used for cable management. You can order the cable management arm listed in [Table 26](#).

Table 26 Cable Management Arm

Product ID (PID)	PID Description
UCSC-CMA-4U	Cable Management Arm for C460 M4

STEP 14 ORDER CISCO FLEXIBLE FLASH SD CARD MODULE (OPTIONAL)

You can order up to two optional blank Cisco Flexible Flash secure digital (SD) cards. The ordering information is listed in [Table 27](#).

Table 27 Secure Digital (SD) Card (blank)

Product ID (PID)	PID Description
UCS-SD-32G-S	32 GB Sandisk 3.0 SD Card for UCS servers (optional)
UCS-SD-64G-S	64 GB SD Card for UCS Servers (optional)

See [Figure 7 on page 64](#) for the location of the SD cards. There are two locations, SD1 and SD2.

STEP 15 ORDER USB DRIVE (OPTIONAL)

You can order up to one optional blank USB drive. The ordering information is listed in [Table 27](#).

Table 28 USB Drive (blank)

Product ID (PID)	PID Description
UCS-USBFLSHB-16GB	UCS Servers 16 GB Flash USB Drive (optional)

See [Figure 7 on page 64](#) for the location of the USB drive socket.

STEP 16 ORDER A TRUSTED PLATFORM MODULE

Trusted Platform Module (TPM) is a computer chip (microcontroller) that can securely store artifacts used to authenticate the platform (server). These artifacts can include passwords, certificates, or encryption keys. A TPM can also be used to store platform measurements that help ensure that the platform remains trustworthy. Authentication (ensuring that the platform can prove that it is what it claims to be) and attestation (a process helping to prove that a platform is trustworthy and has not been breached) are necessary steps to ensure safer computing in all environments.

The TPM ordering information is listed in [Table 29](#).

Table 29 Trusted Platform Module

Product ID (PID)	PID Description
UCSX-TPM1-001	Trusted Platform Module for UCS
UCSX-TPM1-002	Trusted Platform Module 2.0 for UCS servers (LPC based)



NOTE: The module used in this server conforms to TPM v1.2/1.3, as defined by the Trusted Computing Group (TCG).

STEP 17 ORDER A BEZEL (OPTIONAL)

The bezel ordering information is listed in [Table 29](#).

Table 30 Available Bezels

Product ID (PID)	PID Description
UCSC-BZL-EX ¹	Optional bezel for UCS C460 M4 rack server
UCSC-BZL-EX-UPG ²	C460 M4 Security Bezel and Upgrade Kit

Notes . . .

1. For systems shipped after April 2015
2. For systems shipped after April 2015. Includes a bezel and an upgrade kit. The upgrade kit is needed to secure the bezel to the older chassis.

STEP 18 CHOOSE OPERATING SYSTEM AND VALUE-ADDED SOFTWARE

Several software programs are available. Select as desired from [Table 31](#).

Table 31 OSs and Value-Added Software

PID Description	Product ID (PID)
Cisco One	
C1F2PUCSK9	Cisco ONE Foundation Perpetual UCS
C1A1PUCSK9	Cisco ONE Enterprise Cloud Perpetual UCS
C1UCS-OPT-OUT	Cisco One Data Center Compute Opt Out Option
Energy Management (JouleX)	
CEM-DC-ENERGY	Cisco Energy Management(JouleX) DataCenter License 1 Device More
UCS Director	
CUIC-PHY-SERV-BM-U	Cisco UCS Director Resource Lic - 1 Phy Sevr node bare metal
CUIC-PHY-SERV-U	Cisco UCS Director Resource Lic - One physical Server node
CUIC-TERM	Acceptance of Cisco UCS Director License Terms
UCS Performance Manager	
UCS-PM-IE	UCS Performance Manager
UCS-PM-EE	UCS Performance Manager Express
EVAL-UCS-PM-IE	UCS Performance Manager - 90 days evaluation
EVAL-UCS-PM-EE	UCS Performance Manager Express - 90 days evaluation
Nexus 1000V for Hyper-V and vSphere	
N1K-VSG-UCS-BUN	Nexus 1000V Adv Edition for vSphere Paper License Qty 1
IMC Supervisor	
CIMC-SUP-B10	IMC Supervisor- Branch Mgt SW for C & E-Series up to 1K Svrs
CIMC-SUP-B02	IMC Supervisor- Branch Mgt SW for C & E-Series up to 250 Svrs
UCS Multi-Domain Manager	
UCS-MDMGR-100S	UCS Multi-Domain Manager (Central) Per Server License (100+)
UCS-MDMGR-50S	UCS Multi-Domain Manager (Central) Per Server License (50+)
UCS-MDMGR-1S	UCS Multi-Domain Manager (Central) Per Server License
UCS-MDMGR-10S	UCS Multi-Domain Manager (Central) Per Server License (10+)
UCS-MDMGR-1DMN	UCS Multi-Domain Manager (Central) Per Domain License
VMware vCenter	
VMW-VCS-STD-1A	VMware vCenter 6 Server Standard, 1 yr support required
VMW-VCS-STD-3A	VMware vCenter 6 Server Standard, 3 yr support required
VMW-VCS-STD-5A	VMware vCenter 6 Server Standard, 5 yr support required
VMW-VCS-FND-1A	VMware vCenter 6 Server Foundation (3 Host), 1 yr supp reqd
VMW-VCS-FND-3A	VMware vCenter 6 Server Foundation (3 Host), 3 yr supp reqd
VMW-VCS-FND-5A	VMware vCenter 6 Server Foundation (3 Host), 5 yr supp reqd

Table 31 OSs and Value-Added Software (continued)

PID Description	Product ID (PID)
Microsoft Windows Server	
MSWS-12-ST2S	Windows Server 2012 Standard (2 CPU/2 VMs)
MSWS-12-DC2S	Windows Server 2012 Datacenter (2 CPU/Unlimited VMs)
MSWS-12-ST2S-NS	Windows Server 2012 Standard (2 CPU/2 VMs) No Cisco Svc
MSWS-12-DC2S-NS	Windows Server 2012 Datacenter (2 CPU/Unlim VM) No Cisco Svc
MSWS-12R2-ST2S	Windows Server 2012 R2 Standard (2 CPU/2 VMs)
MSWS-12R2-DC2S	Windows Server 2012 R2 Datacenter (2 CPU/Unlimited VMs)
MSWS-12R2-ST2S-NS	Windows Server 2012 R2 Standard (2 CPU/2 VMs) No Cisco SVC
MSWS-12R2-DC2S-NS	Windows Server 2012 R2 Datacen (2 CPU/Unlim VM) No Cisco Svc
Red Hat	
RHEL-2S2V-3A	Red Hat Enterprise Linux (1-2 CPU,1-2 VN); 3-Yr Support Req
RHEL-2S2V-1A	Red Hat Enterprise Linux (1-2 CPU,1-2 VN); 1-Yr Support Req
VMware	
VMW-VSP-EPL-5A	VMware vSphere 6 Ent Plus (1 CPU), 5-yr, Support Required
VMW-VSP-STD-1A	VMware vSphere 6 Standard (1 CPU), 1-yr, Support Required
VMW-VSP-STD-3A	VMware vSphere 6 Standard (1 CPU), 3-yr, Support Required
VMW-VSP-EPL-3A	VMware vSphere 6 Ent Plus (1 CPU), 3-yr, Support Required
VMW-VSP-EPL-1A	VMware vSphere 6 Ent Plus (1 CPU), 1-yr, Support Required
VMW-VSP-STD-5A	VMware vSphere 6 Standard (1 CPU), 5-yr, Support Required
SLES SAP	
SLES-SAP-2S2V-1S	SLES for SAP Apps (1-2 CPU, 1-2 VM); Priority 1-Yr SnS
SLES-SAP-2SUV-1S	SLES for SAP Apps (1-2 CPU, Unl VM); Priority 1-Yr SnS
SLES-SAP-2S2V-3S	SLES for SAP Apps (1-2 CPU, 1-2 VM); Priority 3-Yr SnS
SLES-SAP-2SUV-3S	SLES for SAP Apps (1-2 CPU, Unl VM); Priority 3-Yr SnS
SLES-SAP-2S2V-5S	SLES for SAP Apps (1-2 CPU, 1-2 VM); Priority 5-Yr SnS
SLES-SAP-2SUV-5S	SLES for SAP Apps (1-2 CPU, Unl VM); Priority 5-Yr SnS
SLES-SAP-2S2V-5A	SLES for SAP Apps (1-2 CPU, 1-2 VM); 5-Yr Support Reqd
SLES-SAP-2SUV-3A	SLES for SAP Apps (1-2 CPU, Unl VM); 3-Yr Support Reqd
SLES-SAP-2S2V-3A	SLES for SAP Apps (1-2 CPU, 1-2 VM); 3-Yr Support Reqd
SLES-SAP-2SUV-5A	SLES for SAP Apps (1-2 CPU, Unl VM); 5-Yr Support Reqd
SLES-SAP-2S2V-1A	SLES for SAP Apps (1-2 CPU, 1-2 VM); 1-Yr Support Reqd
SLES-SAP-2SUV-1A	SLES for SAP Apps (1-2 CPU, Unl VM); 1-Yr Support Reqd
SUSE	
SLES-2S2V-1A	SUSE Linux Enterprise Svr (1-2 CPU,1-2 VM); 1-Yr Support Req
SLES-2SUV-1A	SUSE Linux Enterprise Svr (1-2 CPU,Unl VM); 1-Yr Support Req
SLES-2S2V-3A	SUSE Linux Enterprise Svr (1-2 CPU,1-2 VM); 3-Yr Support Req
SLES-2SUV-3A	SUSE Linux Enterprise Svr (1-2 CPU,Unl VM); 3-Yr Support Req

Table 31 OSs and Value-Added Software (continued)

PID Description	Product ID (PID)
SLES-2S2V-5A	SUSE Linux Enterprise Svr (1-2 CPU,1-2 VM); 5-Yr Support Req
SLES-2SUV-5A	SUSE Linux Enterprise Svr (1-2 CPU,Unl VM); 5-Yr Support Req
SLES-2S2V-1S	SUSE Linux Enterprise Svr (1-2 CPU,1-2 VM); Prio 1-Yr SnS
SLES-2SUV-1S	SUSE Linux Enterprise Svr (1-2 CPU,Unl VM); Prio 1-Yr SnS
SLES-2S2V-3S	SUSE Linux Enterprise Svr (1-2 CPU,1-2 VM); Prio 3-Yr SnS
SLES-2SUV-3S	SUSE Linux Enterprise Svr (1-2 CPU,Unl VM); Prio 3-Yr SnS
SLES-2S2V-5S	SUSE Linux Enterprise Svr (1-2 CPU,1-2 VM); Prio 5-Yr SnS
SLES-2SUV-5S	SUSE Linux Enterprise Svr (1-2 CPU,Unl VM); Prio 5-Yr SnS
SLES-2S-HA-1S	SUSE Linux High Availability Ext (1-2 CPU); 1yr SnS
SLES-2S-HA-3S	SUSE Linux High Availability Ext (1-2 CPU); 3yr SnS
SLES-2S-HA-5S	SUSE Linux High Availability Ext (1-2 CPU); 5yr SnS
SLES-2S-GC-1S	SUSE Linux GEO Clustering for HA (1-2 CPU); 1yr Sns
SLES-2S-GC-3S	SUSE Linux GEO Clustering for HA (1-2 CPU); 3yr SnS
SLES-2S-GC-5S	SUSE Linux GEO Clustering for HA (1-2 CPU); 5yr SnS

STEP 19 CHOOSE OPERATING SYSTEM MEDIA KIT

Choose the optional operating system media listed in [Table 32](#).

Table 32 OS Media

Product ID (PID)	PID Description
RHEL-6	RHEL 6 Recovery Media Only (Multilingual)
MSWS-12-ST2S-RM	Windows Server 2012 Standard (2 CPU/2 VMs) Recovery Media
MSWS-12-DC2S-RM	Windows Server 2012 Datacenter (2 CPU/Unlimited VM) Rec Media

STEP 20 CHOOSE SERVICE and SUPPORT LEVEL

A variety of service options are available, as described in this section.

Unified Computing Warranty, No Contract

If you have noncritical implementations and choose to have no service contract, the following coverage is supplied:

- Three-year parts coverage.
- Next business day (NBD) onsite parts replacement eight hours a day, five days a week.
- 90-day software warranty on media.
- Ongoing downloads of BIOS, drivers, and firmware updates.
- UCSM updates for systems with Unified Computing System Manager. These updates include minor enhancements and bug fixes that are designed to maintain the compliance of UCSM with published specifications, release notes, and industry standards.

SMARTnet for UCS

For support of the entire Unified Computing System, Cisco offers the Cisco SMARTnet for UCS Service. This service provides expert software and hardware support to help sustain performance and high availability of the unified computing environment. Access to Cisco Technical Assistance Center (TAC) is provided around the clock, from anywhere in the world.

For UCS servers, there is Smart Call Home, which provides proactive, embedded diagnostics and real-time alerts. For systems that include Unified Computing System Manager, the support service includes downloads of UCSM upgrades. The Cisco SMARTnet for UCS Service includes flexible hardware replacement options, including replacement in as little as two hours. There is also access to Cisco's extensive online technical resources to help maintain optimal efficiency and uptime of the unified computing environment. You can choose a desired service listed in [Table 33](#).

Table 33 Cisco SMARTnet for UCS Service

Product ID (PID)	On Site?	Description
CON-PREM-C460M4	Yes	ONSITE 24X7X2 C460 M4 Rack Server
CON-OSP-C460M4	Yes	ONSITE 24X7X4 C460 M4 Rack Server
CON-OSE-C460M4	Yes	ONSITE 8X5X4 C460 M4 Rack Server
CON-OS-C460M4	Yes	ONSITE 8X5XNBD C460 M4 Rack Server
CON-S2P-C460M4	No	SMARTNET 24X7X2 C460 M4 Rack Server
CON-SNTP-C460M4	No	SMARTNET 24X7X4 C460 M4 Rack Server
CON-SNTE-C460M4	No	SMARTNET 8X5X4 C460 M4 Rack Server
CON-SNT-C460M4	No	SMARTNET 8X5XNBD C460 M4 Rack Server

SMARTnet for UCS Hardware Only Service

For faster parts replacement than is provided with the standard Cisco Unified Computing System warranty, Cisco offers the Cisco SMARTnet for UCS Hardware Only Service. You can choose from two levels of advanced onsite parts replacement coverage in as little as four hours. SMARTnet for UCS Hardware Only Service provides remote access any time to Cisco support professionals who can determine if a return materials authorization (RMA) is required. You can choose a service listed in [Table 34](#).

Table 34 SMARTnet for UCS Hardware Only Service

Product ID (PID)	Service Level GSP	On Site?	Description
CON-UCW7-C460M4	UCW7	Yes	UC PLUS 24X7X40S C460 M4 Rack Server
CON-UCW5-C460M4	UCW5	Yes	UC PLUS 8X5XNBDOS C460 M4 Rack Server

Unified Computing Partner Support Service

Cisco Partner Support Service (PSS) is a Cisco Collaborative Services service offering that is designed for partners to deliver their own branded support and managed services to enterprise customers. Cisco PSS provides partners with access to Cisco's support infrastructure and assets to help them:

- Expand their service portfolios to support the most complex network environments
- Lower delivery costs
- Deliver services that increase customer loyalty

Partner Unified Computing Support Options enable eligible Cisco partners to develop and consistently deliver high-value technical support that capitalizes on Cisco intellectual assets. This helps partners to realize higher margins and expand their practice.

Partner Unified Computing Support Options are available to Cisco PSS partners. For additional information, see the following URL:

www.cisco.com/go/partnerucssupport

The two Partner Unified Computing Support Options include:

- Partner Support Service for UCS
- Partner Support Service for UCS Hardware Only

Partner Support Service for UCS provides hardware and software support, including triage support for third party software, backed by Cisco technical resources and level three support. See [Table 35](#).

Table 35 Partner Support Service for UCS

Product ID (PID)	Service Level GSP	On Site?	Description
CON-PSJ1-C460M4	PSJ1	No	UCS SUPP PSS 8X5XNBD C460 M4 Rack Server
CON-PSJ2-C460M4	PSJ2	No	UCS SUPP PSS 8X5X4 C460 M4 Rack Server
CON-PSJ3-C460M4	PSJ3	No	UCS SUPP PSS 24X7X4 C460 M4 Rack Server
CON-PSJ4-C460M4	PSJ4	No	UCS SUPP PSS 24X7X2 C460 M4 Rack Server
CON-PSJ6-C460M4	PSJ6	Yes	UCS SUPP PSS 8x5x4 Onsite
CON-PSJ7-C460M4	PSJ7	Yes	UCS SUPP PSS 24X7X4 Onsite
CON-PSJ8-C460M4	PSJ8	Yes	UCS SUPP PSS 24X7X2 Onsite

Partner Support Service for UCS Hardware Only provides customers with replacement parts in as little as two hours. See [Table 36](#).

Table 36 Partner Support Service for UCS (Hardware Only)

Product ID (PID)	Service Level GSP	On Site?	Description
CON-PSW2-C460M4	PSW2	No	UCS HW ONLY PSS 8X5X4 C460 M4 Rack Server
CON-PSW3-C460M4	PSW3	No	UCS HW ONLY PSS 24X7X4 C460 M4 Rack Server
CON-PSW4-C460M4	PSW4	No	UCS HW ONLY PSS 24X7X2 C460 M4 Rack Server
CON-PSW6-C460M4	PSW6	Yes	UCS HW ONLY PSS 8x5x4 Onsite
CON-PSW7-C460M4	PSW7	Yes	UCS HW ONLY PSS 24x7x4 Onsite

Cisco Combined Services

Combined Services makes it easier to purchase and manage required services under one contract. SMARTnet services for UCS help increase the availability of your vital data center infrastructure and realize the most value from your unified computing investment. The more benefits you realize from the Cisco Unified Computing System (Cisco UCS), the more important the technology becomes to your business. These services allow you to:

- Optimize the uptime, performance, and efficiency of your UCS
- Protect your vital business applications by rapidly identifying and addressing issues

- Strengthen in-house expertise through knowledge transfer and mentoring
- Improve operational efficiency by allowing UCS experts to augment your internal staff resources
- Enhance business agility by diagnosing potential issues before they affect your operations

Unified Computing Drive Retention Service

With the Cisco Unified Computing Drive Retention (UCDR) Service, you can obtain a new disk drive in exchange for a faulty drive without returning the faulty drive. In exchange for a Cisco replacement drive, you provide a signed Certificate of Destruction (CoD) confirming that the drive has been removed from the system listed, is no longer in service, and has been destroyed.

Sophisticated data recovery techniques have made classified, proprietary, and confidential information vulnerable, even on malfunctioning disk drives. The UCDR service enables you to retain your drives and ensures that the sensitive data on those drives is not compromised, which reduces the risk of any potential liabilities. This service also enables you to comply with regulatory, local, and federal requirements.

If your company has a need to control confidential, classified, sensitive, or proprietary data, you might want to consider one of the Drive Retention Services listed in [Table 37](#), [Table 38](#), or [Table 39](#).



NOTE: Cisco does not offer a certified drive destruction service as part of this service.

Table 37 Drive Retention Service Options

Service Description	Service Program Name	Service Level GSP	Service Level	Product ID (PID)
SMARTnet for UCS Service with Drive Retention	UCS DR	UCSD7	24x7x4 Onsite	CON-UCSD7-C460M4
		UCSD5	8x5xNBD Onsite	CON-UCSD5-C460M4
SMARTnet for UCS HW ONLY+Drive Retention	UCS HW+DR	UCWD7	24x7x4 Onsite	CON-UCWD7-C460M4
		UCWD5	8x5xNBD Onsite	CON-UCWD5-C460M4

Table 38 Drive Retention Service Options for Partner Support Service

Service Description	Service Level GSP	Service Level	Product ID (PID)
Partner Support Service for UCS Drive Retention	PSJD6	8x5x4 Onsite	CON-PSJD6-C460M4
	PSJD7	24x7x4 Onsite	CON-PSJD7-C460M4

Table 39 Drive Retention Service Options for Partner Support Service (Hardware Only)

Service Description	Service Level GSP	Service Level	Product ID (PID)
Partner Support Service for UCS Drive Retention Hardware only	PSWD6	8x5x4 Onsite	CON-PSWD6-C460M4
	PSWD7	24x7x4 Onsite	CON-PSWD7-C460M4

For more service and support information, see the following URL:

http://www.cisco.com/en/US/services/ps2961/ps10312/Unified_Computing_Services_Overview.pdf

For a complete listing of available services for Cisco Unified Computing System, see this URL:

http://www.cisco.com/en/US/products/ps10312/serv_group_home.html

OPTIONAL STEP - ORDER RACKS

The optional R42612 rack is available from Cisco for the C-Series servers, including the C240 M4 SFF server. This rack is a standard 19-inch rack and can be ordered with a variety of options, as listed in [Table 40](#). Racks are shipped separately from the C240 M4 SFF server.

Table 40 Racks and Rack Options

Product ID (PID)	PID Description
RACK2-UCS	Cisco R42612 expansion rack, no side panels. This type of rack is used for multiple-rack deployments.
RACK2-UCS2	Cisco R42612 static (standard) rack, with side panels. This type of rack is used for single-rack and end of row deployments. Side panels are needed for racks at the ends of multiple-rack deployments. For example, when configuring a row of 5 racks, order 1 standard rack plus 4 expansion racks. Apply the side panels from the standard rack to the racks at each end of the row.
RACK-BLANK-001	Blanking panels (qty 12), 1U, plastic, toolless. Recommended to ensure proper airflow. Fill all empty RU spaces in the front of the rack. Because each blanking panel PID includes 12 panels, use the following calculation: 42RU - occupied RU = available RU. Divide available RU by 12 to determine PID order quantity.
RACK-CBLMGT-001	Cable mgt D rings (qty 10), metal. Use the D rings to bundle system cables to ensure proper airflow.
RACK-CBLMGT-003	Brush strip (qty 1), 1 U. The brush strip promotes proper airflow while allowing cables to be passed from the front to the rear of the rack.
RACK-CBLMGT-011	Cable mgt straps (qty 10), Velcro. Use the Velcro straps to bundle system cables to ensure proper airflow.
RACK-FASTEN-001	Mounting screws (qty 100), M6. The rack ships with nuts and screws, but extras may be ordered.
RACK-FASTEN-002	Cage nuts (qty 50), M6. The rack ships with nuts and screws, but extras may be ordered.
RACK2-JOIN-001	Rack joining kit. Use the kit to connect adjacent racks within a row. Order 1 unit less than the number of racks in the row.
RACK2-GRND-001	Cisco R42612 grounding kit

For more information about the R42612 rack, see [RACKS on page 73](#).

OPTIONAL STEP - ORDER PDU

An optional power distribution unit (PDU) is available from Cisco for the C-Series rack servers, including the C240 M4 server. This PDU is available in a zero rack unit (RU) style or horizontal PDU style (see [Table 41](#)). For more information about the PDU, see [PDUs on page 75](#).

Table 41 Available PDUs

Product ID (PID)	Description	Plug	Country
Zero-RU PDUs			
RP208-30M1P-6-36	30 A, single-phase, vertical-mount PDU with 6 C19 and 36 C13 connectors	L6-30P	North America
RP208-30M3P-6-30	30 A, three-phase, vertical-mount PDU with 6 C19 and 30 C13 connectors	L15-30P	North America
RP208-60M3P-12-9	60 A, three-phase, vertical-mount PDU with 12 C19 and 9 C13 connectors	IEC60309 460P9	North America
RP230-32M1P-6-36	32 A, single-phase, button-mount (rear and sides) PDU with 6 C19 and 36 C13 connectors	IEC60309 332P6	International
RP230-32M3P-12-12	32 A, single-phase, button-mount (rear and sides) PDU with 12 C19 and 12 C13 connectors	IEC60309 532P6	International
Horizontal PDUs (occupy RU space)			
RP208-30M1P-4-8 (1 RU space)	30 A, single-phase, horizontal-mount PDU with 4 C19 and 8 C13 connectors	L6-30P	North America
RP208-60M3P-12 (2 RU spaces)	48 A, three-phase, horizontal-mount PDU with 12 C19 connectors	L15-30P	North America

SUPPLEMENTAL MATERIAL

CHASSIS

An internal view of the C460 M4 chassis with the top cover removed is shown in *Figure 7*.

Figure 7 C460 M4 With Top Cover Removed

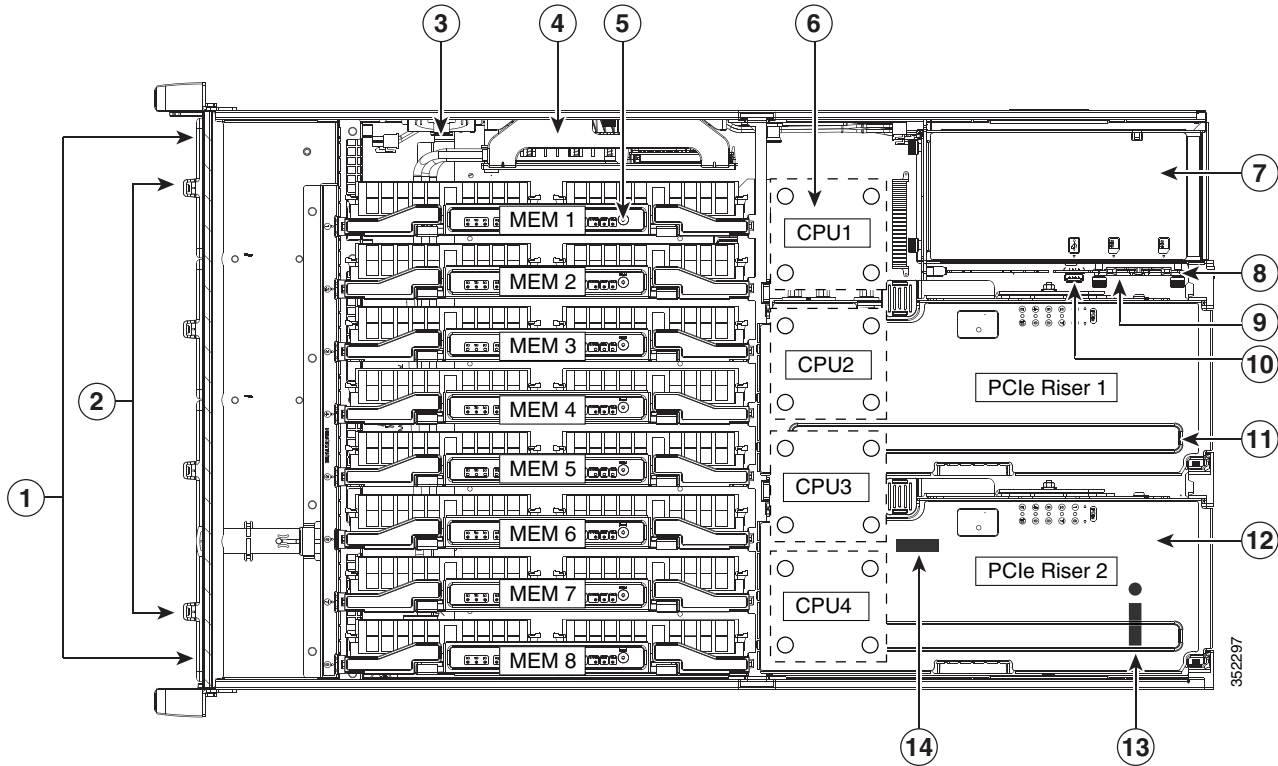

1	Drive bays (up to twelve 2.5-inch drives) All 12 bays support SAS/SATA drives. SAS and SATA drives are hot-swappable ¹ .	8	Media riser card (includes two bays for Cisco FlexFlash drives and an internal USB port)
2	Fan modules (four, hot-swappable and front-accessible)	9	Cisco FlexFlash drive (SD card) bays (two on the media riser card)
3	RAID backup unit (supercap power module) mounting bracket on chassis wall	10	Internal, vertical USB 2.0 port (on the media riser card)
4	RAID controller card socket (dedicated internal PCIe socket)	11	PCIe riser 1 (PCIe slots 1-5)

5	Memory risers with DIMMs (8 risers with 12 DIMM sockets each) Memory risers are hot-pluggable.	12	PCIe riser 2 (PCIe slots 6-10)
6	CPUs and heatsinks (two or four) The CPUs and their heatsinks are below the memory risers and PCIe risers.	13	TPM socket and screw hole (on motherboard, not visible under riser in this view)
7	Power supplies (four) Redundant as 2+2, hot-swappable	14	RTC battery (on motherboard, not visible under riser in this view)

Notes . . .

- Hot-swappable = No preconditioning or shutdown of the component is required before removal while the server is powered on.

CPUs and DIMMs

Physical Layout

Each CPU controls four serial memory interface 2 (SMI-2) channels (see *Figure 4 on page 14*). There is one memory riser for every two CPU channels. There are therefore two memory risers per CPU. Each CPU channel drives a memory buffer on a riser card, and each memory buffer converts a CPU SMI into two DDR3 subchannels that each read and write three DIMMs on a memory riser.

The DIMM layout of a memory riser is shown in *Figure 8*.

Figure 8 Memory Riser DIMM Layout

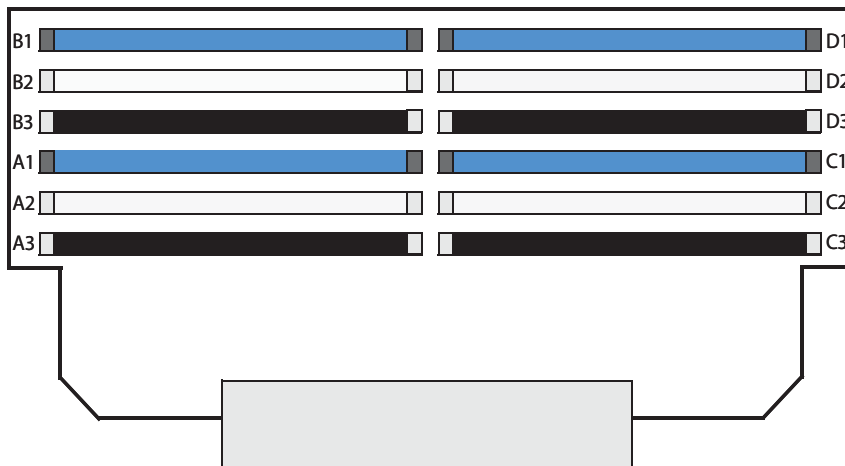

In *Figure 8*, the buffers and channels are:

- Buffer 1, subchannel A: slots A1 (blue), A2 (white), and A3 (black)
- Buffer 1, subchannel B: slots B1 (blue), B2 (white), and B3 (black)
- Buffer 2, subchannel C: slots C1 (blue), C2 (white), and C3 (black)
- Buffer 2, subchannel D: slots D1 (blue), D2 (white), and D3 (black)

Memory Population Rules

When considering the memory configuration of your server, you should observe the following:

- Only 1 memory riser on any CPU is required to boot the system.
- Memory risers on non-installed CPUs will not work.
- Memory risers do not need to be populated in pairs
- If not installing all risers, for optimal CPU air flow, even numbered risers should be installed first.
- Each memory riser has two memory buffers, each of which controls two DDR channels with up to 3 DIMMs per channel.
- For optimal performance DIMMs should be spread evenly across all CPUs and DDR channels
- DIMM1 of a channel should be installed first (blue socket), then DIMM2 (white socket), then DIMM3 (black socket)

Memory Population Order

When populating DIMMs on the memory riser cards, observe the population order shown in the following tables:

- Population order for 4 CPUs and 8 risers: see [Table 42 on page 67](#).
- Population order for 2 CPUs and 4 risers: see [Table 43 on page 71](#).

Table 42 DIMM Population Order for 4 CPUs and 8 Memory Risers

Installation Order	DIMM	CPU	Riser	Socket	Color
Install first	1	CPU 1	1	A1	Blue
	2	CPU 2	3	A1	Blue
	3	CPU 3	5	A1	Blue
	4	CPU 4	7	A1	Blue
	5	CPU 1	2	A1	Blue
	6	CPU 2	4	A1	Blue
	7	CPU 3	6	A1	Blue
	8	CPU 4	8	A1	Blue
9	CPU 1	1	C1	Blue	
10	CPU 2	3	C1	Blue	
11	CPU 3	5	C1	Blue	
12	CPU 4	7	C1	Blue	
13	CPU 1	2	C1	Blue	
14	CPU 2	4	C1	Blue	
15	CPU 3	6	C1	Blue	
16	CPU 4	8	C1	Blue	
17	CPU 1	1	B1	Blue	
18	CPU 2	3	B1	Blue	
19	CPU 3	5	B1	Blue	
20	CPU 4	7	B1	Blue	
21	CPU 1	2	B1	Blue	
22	CPU 2	4	B1	Blue	
23	CPU 3	6	B1	Blue	
24	CPU 4	8	B1	Blue	
25	CPU 1	1	D1	Blue	
26	CPU 2	3	D1	Blue	
27	CPU 3	5	D1	Blue	
28	CPU 4	7	D1	Blue	

Table 42 DIMM Population Order for 4 CPUs and 8 Memory Risers (*continued*)

Installation Order	DIMM	CPU	Riser	Socket	Color
	29	CPU 1	2	D1	Blue
	30	CPU 2	4	D1	Blue
	31	CPU 3	6	D1	Blue
	32	CPU 4	8	D1	Blue
	33	CPU 1	1	A2	White
	34	CPU 2	3	A2	White
	35	CPU 3	5	A2	White
	36	CPU 4	7	A2	White
	37	CPU 1	2	A2	White
	38	CPU 2	4	A2	White
	39	CPU 3	6	A2	White
	40	CPU 4	8	A2	White
	41	CPU 1	1	C2	White
	42	CPU 2	3	C2	White
	43	CPU 3	5	C2	White
	44	CPU 4	7	C2	White
	45	CPU 1	2	C2	White
	46	CPU 2	4	C2	White
	47	CPU 3	6	C2	White
	48	CPU 4	8	C2	White
	49	CPU 1	1	B2	White
	50	CPU 2	3	B2	White
	51	CPU 3	5	B2	White
	52	CPU 4	7	B2	White
	53	CPU 1	2	B2	White
	54	CPU 2	4	B2	White
	55	CPU 3	6	B2	White
	56	CPU 4	8	B2	White

Table 42 DIMM Population Order for 4 CPUs and 8 Memory Risers (*continued*)

Installation Order	DIMM	CPU	Riser	Socket	Color
	57	CPU 1	1	D2	White
	58	CPU 2	3	D2	White
	59	CPU 3	5	D2	White
	60	CPU 4	7	D2	White
	61	CPU 1	2	D2	White
	62	CPU 2	4	D2	White
	63	CPU 3	6	D2	White
	64	CPU 4	8	D2	White
	65	CPU 1	1	A3	Black
	66	CPU 2	3	A3	Black
	67	CPU 3	5	A3	Black
	68	CPU 4	7	A3	Black
	69	CPU 1	2	A3	Black
	70	CPU 2	4	A3	Black
	71	CPU 3	6	A3	Black
	72	CPU 4	8	A3	Black
	73	CPU 1	1	C3	Black
	74	CPU 2	3	C3	Black
	75	CPU 3	5	C3	Black
	76	CPU 4	7	C3	Black
	77	CPU 1	2	C3	Black
	78	CPU 2	4	C3	Black
	79	CPU 3	6	C3	Black
	80	CPU 4	8	C3	Black
	81	CPU 1	1	B3	Black
	82	CPU 2	3	B3	Black
	83	CPU 3	5	B3	Black
	84	CPU 4	7	B3	Black

Table 42 DIMM Population Order for 4 CPUs and 8 Memory Risers (*continued*)

Installation Order	DIMM	CPU	Riser	Socket	Color
	85	CPU 1	2	B3	Black
	86	CPU 2	4	B3	Black
	87	CPU 3	6	B3	Black
	88	CPU 4	8	B3	Black
	89	CPU 1	1	D3	Black
	90	CPU 2	3	D3	Black
	91	CPU 3	5	D3	Black
	92	CPU 4	7	D3	Black
	93	CPU 1	2	D3	Black
	94	CPU 2	4	D3	Black
	95	CPU 3	6	D3	Black
Install Last	96	CPU 4	8	D3	Black

Table 43 DIMM Population Order for 2 CPUs and 4 Memory Risers

Installation Order	DIMM	CPU	Riser	Socket	Color
Install first	1	CPU 1	1	A1	Blue
	2	CPU 2	3	A1	Blue
	3	CPU 1	2	A1	Blue
	4	CPU 2	4	A1	Blue
	5	CPU 1	1	C1	Blue
	6	CPU 2	3	C1	Blue
	7	CPU 1	2	C1	Blue
	8	CPU 2	4	C1	Blue
	9	CPU 1	1	B1	Blue
	10	CPU 2	3	B1	Blue
	11	CPU 1	2	B1	Blue
	12	CPU 2	4	B1	Blue
	13	CPU 1	1	D1	Blue
	14	CPU 2	3	D1	Blue
	15	CPU 1	2	D1	Blue
	16	CPU 2	4	D1	Blue
	17	CPU 1	1	A2	White
	18	CPU 2	3	A2	White
	19	CPU 1	2	A2	White
	20	CPU 2	4	A2	White
	21	CPU 1	1	C2	White
	22	CPU 2	3	C2	White
	23	CPU 1	2	C2	White
	24	CPU 2	4	C2	White
	25	CPU 1	1	B2	White
	26	CPU 2	3	B2	White
	27	CPU 1	2	B2	White
	28	CPU 2	4	B2	White

Table 43 DIMM Population Order for 2 CPUs and 4 Memory Risers (*continued*)

Installation Order	DIMM	CPU	Riser	Socket	Color
	29	CPU 1	1	D2	White
	30	CPU 2	3	D2	White
	31	CPU 1	2	D2	White
	32	CPU 2	4	D2	White
	33	CPU 1	1	A3	Black
	34	CPU 2	3	A3	Black
	35	CPU 1	2	A3	Black
	36	CPU 2	4	A3	Black
	37	CPU 1	1	C3	Black
	38	CPU 2	3	C3	Black
	39	CPU 1	2	C3	Black
	40	CPU 2	4	C3	Black
	41	CPU 1	1	B3	Black
	42	CPU 2	3	B3	Black
	43	CPU 1	2	B3	Black
	44	CPU 2	4	B3	Black
	45	CPU 1	1	D3	Black
	46	CPU 2	3	D3	Black
	47	CPU 1	2	D3	Black
Install last	48	CPU 2	4	D3	Black

RACKS

The Cisco R42612 rack (see [Figure 9 on page 74](#)) is certified for Cisco UCS installation at customer sites and is suitable for the following equipment:

- Cisco UCS B-Series servers and fabric interconnects
- Cisco UCS C-Series and select Nexus switches

The rack is compatible with hardware designed for EIA-standard 19-inch racks. Rack specifications are listed in [Table 44](#).

Table 44 R42612 Specifications

Cisco R42612 Rack	Standard (Static with side panels)	Expansion (Static without Side Panels)
Dimensions (H x W x D)	79.25 x 23.50 x 49.84 in. (2013 x 597 x 1266 mm)	79.25 x 23.50 x 49.84 in. (2013 x 597 x 1266 mm)
Dimensions (H x W x D) with packaging	84.25 x 32 x 54.84 in. (2140 x 813 x 1393 mm)	84.25 x 32 x 54.84 in. (2140 x 813 x 1393 mm)
Distance from front mounting rail to rear mounting rail	29.19 in. (741.5 mm)	29.19 in. (741.5 mm)
Weight	339.51 lb (154 kg)	264.55 lb (120 kg)
Weight with packaging	410.06 lb (186 kg)	335.10 lb (152 kg)
Side panels included	Yes	No
Equipment mounting capacity	42 RU	42 RU
Static load capacity	2700 lb (1224.7 kg)	2700 lb (1224.7 kg)
Dynamic load capacity	N/A	N/A

Figure 9 Cisco R42612 Rack

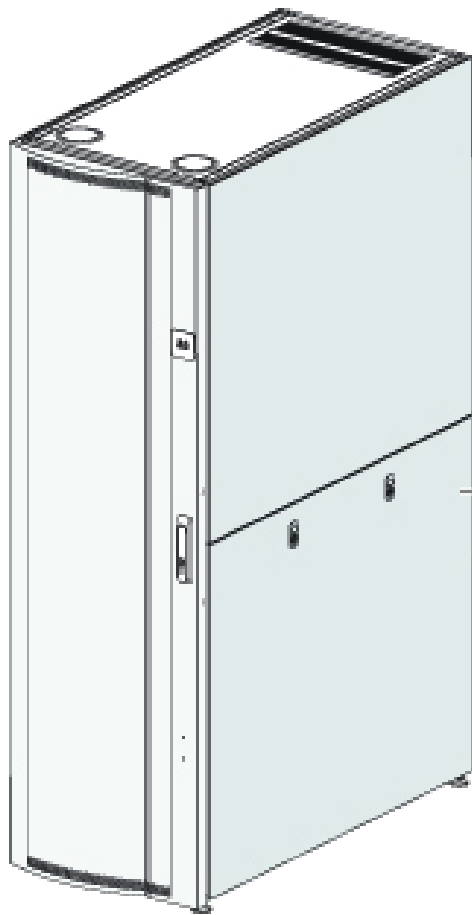

Front View

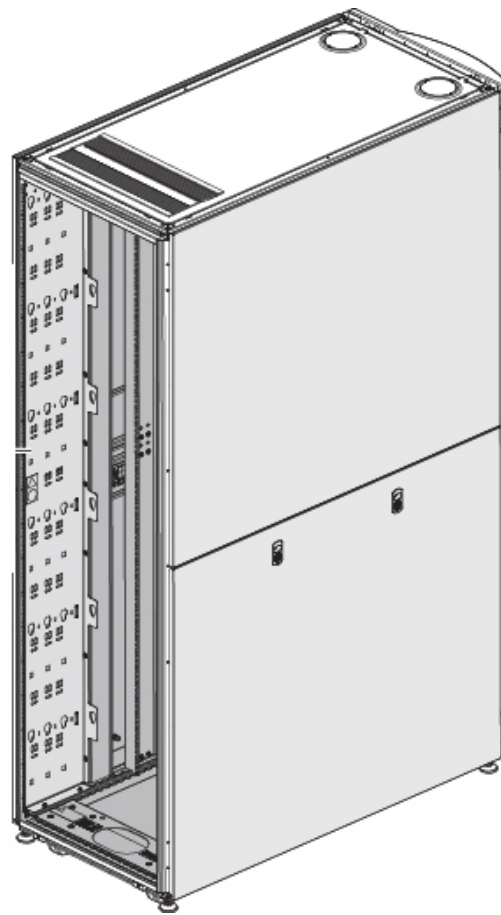

Rear View

PDUs

Cisco RP Series Power Distribution Units (PDUs) offer power distribution with branch circuit protection.

Cisco RP Series PDU models distribute power to up to 42 outlets. The architecture organizes power distribution, simplifies cable management, and enables you to move, add, and change rack equipment without an electrician.

With a Cisco RP Series PDU in the rack, you can replace up to two dozen input power cords with just one. The fixed input cord connects to the power source from overhead or under-floor distribution. Your IT equipment is then powered by PDU outlets in the rack using short, easy-to-manage power cords.

The C-series severs accept the zero-rack-unit (ORU) or horizontal PDU. See [Figure 10](#) for one example of a zero rack unit PDU.

Figure 10 RP208-30M1P-6-36 PDU

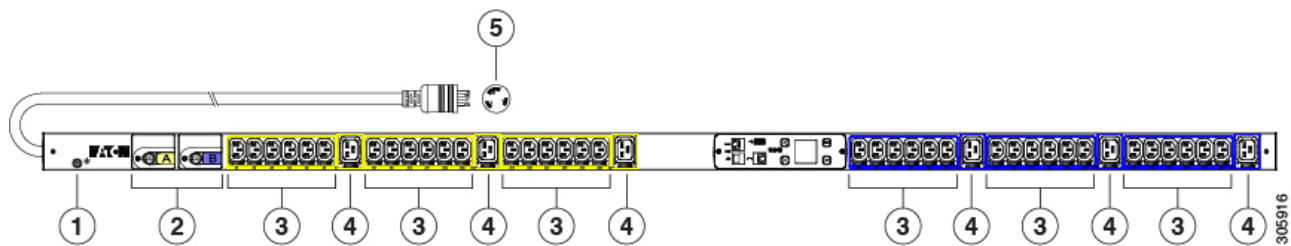

1 = Ground

2 = 20 A circuit breakers

3 = IEC 60320 C13 outlets

4 = EC 60320 C19 outlets

5 = NEMA L6-30P plug

KVM CABLE

The KVM cable provides a connection into the server, providing a DB9 serial connector, a VGA connector for a monitor, and dual USB 2.0 ports for a keyboard and mouse. With this cable, you can create a direct connection to the operating system and the BIOS running on the server.

The KVM cable ordering information is listed in [Table 45](#).

Table 45 KVM Cable

Product ID (PID)	PID Description
N20-BKVM	KVM cable for server console port

Figure 11 KVM Cable

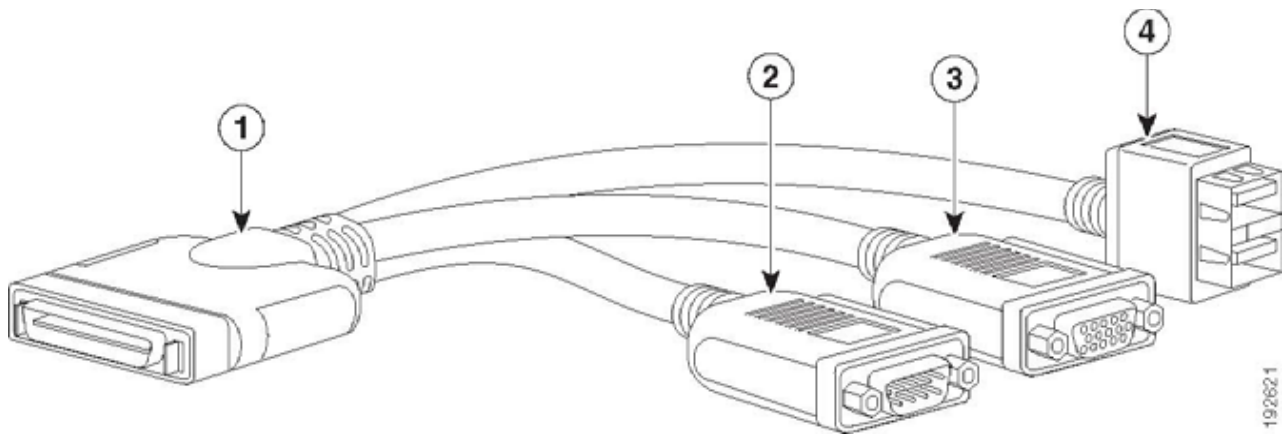

1	Connector (to server front panel)	3	VGA connector (for a monitor)
2	DB-9 serial connector	4	Two-port USB 2.0 connector (for a mouse and keyboard)

TECHNICAL SPECIFICATIONS

Dimensions and Weight

Table 46 UCS C460 M4 Dimensions and Weight¹

Parameter	Value
Height	6.9 in. (175 mm)
Width	19.0 in. (482 mm)
Depth	32.7 in. (830 mm)
Front Clearance	3 in. (7.62 cm)
Side Clearance	1 in. (25.4 mm)
Rear Clearance	6 in. (152.4 mm)
Weight (maximum configuration, including slide rail brackets and cable management arm)	142 lbs (64.4 kg)

Notes . . .

1. The system weight given here is an estimate for a fully configured system and will vary depending on the number of peripheral devices and power supplies.

Power Specifications

The general power specifications for the C460 M4 server are listed in [Table 47](#) and [Table 48](#).

Table 47 UCS C460 M4 1400 W V2 Power Supply (UCSC-PSU2V2-1400W) Power Specifications

Description	Specification
AC input voltage	Voltage Range 200-240 VAC nominal (range:180-264 VAC)
AC input frequency	50 to 60 Hz nominal (range: 47 to 63 Hz)
Maximum Input VA	1700 VA
Maximum output power	1400 W at 200 - 240 VAC
Maximum AC inrush current	35 A (sub-cycle duration)
Maximum holdup time	12 ms at 1400 W
Power supply output voltage	12 VDC
Power supply standby voltage	12 VDC
Efficiency rating	Climate Savers Platinum Efficiency (80Plus Platinum Certified)
Form factor	RSP1 (C-Series 2U and 4U Server)
Input connector	IEC320 C14

Table 48 UCS C460 M4 1200 W Power Supply (UCSC-PSU2V2-1200W) Power Specifications

Description	Specification
AC input voltage	Voltage Range 100-120 VAC, 200-240 VAC nominal (range: 90-132 VAC, 180-264 VAC)
AC input frequency	50 to 60 Hz nominal (range: 47 to 63 Hz)
Maximum AC input current	11A at 100 VAC; 7 A at 200 VAC
Maximum input VA	1456 VA
Maximum output power per power supply	800W at 100-120 VAC; 1200W at 200 - 240 VAC
Maximum AC inrush current	35 A (sub cycle duration)
Maximum holdup time	12 ms @ 1200 W
Power supply output voltage	12 VDC
Power supply efficiency	Climate Savers Platinum Efficiency (80Plus Platinum Certified)
Form Factor	RSP1 (C-Series 2U and 4U Server)
Input connector	IEC320 C14

For configuration-specific power specifications, use the Cisco UCS Power Calculator at:

<http://ucspowercalc.cisco.com>

Environmental Specifications

The power specifications for the C460 M4 server are listed in [Table 49](#).

Table 49 UCS C460 M4 Environmental Specifications

Parameter	Minimum
Temperature operating	10°C to 35°C (50°F to 95°F)
Temperature nonoperating	-40°C to 70°C (-40°F to 158°F)
Altitude	-30 m to 1500 m (-100 ft to 5000 ft)
Humidity nonoperating	95%, noncondensing at temperatures of 25°C (77°F) to 30°C (86°F)

Compliance Requirements

The regulatory compliance requirements for C-Series servers are listed in [Table 50](#).

Table 50 UCS C-Series Regulatory Compliance Requirements

Parameter	Description
Regulatory Compliance	Products should comply with CE Markings per directives 2004/108/EC and 2006/95/EC
Safety	UL 60950-1 Second Edition CAN/CSA-C22.2 No. 60950-1 Second Edition EN 60950-1 Second Edition IEC 60950-1 Second Edition AS/NZS 60950-1 GB4943 2001
EMC - Emissions	47CFR Part 15 (CFR 47) Class A AS/NZS CISPR22 Class A CISPR22 Class A EN55022 Class A ICES003 Class A VCCI Class A EN61000-3-2 EN61000-3-3 KN22 Class A CNS13438 Class A
EMC - Immunity	EN55024 CISPR24 EN300386 KN24



Americas Headquarters
Cisco Systems, Inc.
San Jose, CA

Asia Pacific Headquarters
Cisco Systems (USA) Pte. Ltd.
Singapore

Europe Headquarters
Cisco Systems International BV Amsterdam,
The Netherlands

Cisco has more than 200 offices worldwide. Addresses, phone numbers, and fax numbers are listed on the Cisco Website at www.cisco.com/go/offices.

Cisco and the Cisco Logo are trademarks of Cisco Systems, Inc. and/or its affiliates in the U.S. and other countries. A listing of Cisco's trademarks can be found at www.cisco.com/go/trademarks. Third party trademarks mentioned are the property of their respective owners. The use of the word partner does not imply a partnership relationship between Cisco and any other company. (1005R)