

# Easy UPS 3-Phase Modular

**50-250 kW**

## Installation

380 V, 400 V, 415 V

Latest updates are available on the Schneider Electric website  
09/2022



# Legal Information

The Schneider Electric brand and any trademarks of Schneider Electric SE and its subsidiaries referred to in this guide are the property of Schneider Electric SE or its subsidiaries. All other brands may be trademarks of their respective owners.

This guide and its content are protected under applicable copyright laws and furnished for informational use only. No part of this guide may be reproduced or transmitted in any form or by any means (electronic, mechanical, photocopying, recording, or otherwise), for any purpose, without the prior written permission of Schneider Electric.

Schneider Electric does not grant any right or license for commercial use of the guide or its content, except for a non-exclusive and personal license to consult it on an "as is" basis. Schneider Electric products and equipment should be installed, operated, serviced, and maintained only by qualified personnel.

As standards, specifications, and designs change from time to time, information contained in this guide may be subject to change without notice.

To the extent permitted by applicable law, no responsibility or liability is assumed by Schneider Electric and its subsidiaries for any errors or omissions in the informational content of this material or consequences arising out of or resulting from the use of the information contained herein.



Go to <https://www.productinfo.schneider-electric.com/easyups3pmodular/> or scan the QR code above for digital experience and translated manuals.

# Table of Contents

Important Safety Instructions — SAVE THESE INSTRUCTIONS .....	5
Electromagnetic Compatibility .....	6
Safety Precautions .....	6
Additional Safety Precautions After Installation.....	8
Electrical Safety .....	9
Battery Safety .....	10
Symbols Used in the Product.....	12
Specifications .....	13
Specifications for 50 kW UPS .....	13
Specifications for 100 kW UPS .....	15
Specifications for 150 kW UPS .....	17
Specifications for 200 kW UPS .....	19
Specifications for 250 kW UPS .....	21
Required Upstream Protection.....	23
Recommended Cables Sizes .....	24
Recommended Bolt and Lug Sizes .....	25
Torque Specifications.....	25
Requirements for a Third Party Battery Solution.....	27
Third Party Battery Breaker Requirements .....	27
Guidance for Organizing Battery Cables .....	28
UPS Weights and Dimensions .....	29
Clearance .....	30
Environment.....	31
Compliance.....	32
Overview .....	33
Single System Overview .....	33
Parallel System Overview .....	36
Installation Procedure .....	38
Position the UPS.....	39
Install the Seismic Anchoring (Option) .....	41
Prepare the UPS for Top Cable Entry .....	45
Prepare for TN-C Earthing System .....	49
Install the Neutral Disconnection Kit (Option).....	50
Connect the Power Cables for the UPS with One Internal Switch .....	52
Connect the Power Cables for the UPS with Four Internal Switches.....	55
Connect the Signal Cables .....	58
Connect the Signal Cables from Switchgear and Third-Party Auxiliary Products .....	62
Connect the Modbus Cables.....	65
Connect the PBUS Cables .....	67
Install the Power Module(s).....	68

Backfeed Protection .....	70
Final Installation .....	74

# Important Safety Instructions — SAVE THESE INSTRUCTIONS

Read these instructions carefully and look at the equipment to become familiar with it before trying to install, operate, service or maintain it. The following safety messages may appear throughout this manual or on the equipment to warn of potential hazards or to call attention to information that clarifies or simplifies a procedure.



The addition of this symbol to a “Danger” or “Warning” safety message indicates that an electrical hazard exists which will result in personal injury if the instructions are not followed.



This is the safety alert symbol. It is used to alert you to potential personal injury hazards. Obey all safety messages with this symbol to avoid possible injury or death.

## **DANGER**

**DANGER** indicates a hazardous situation which, if not avoided, **will result in death or serious injury.**

**Failure to follow these instructions will result in death or serious injury.**

## **WARNING**

**WARNING** indicates a hazardous situation which, if not avoided, **could result in death or serious injury.**

**Failure to follow these instructions can result in death, serious injury, or equipment damage.**

## **CAUTION**

**CAUTION** indicates a hazardous situation which, if not avoided, **could result in minor or moderate injury.**

**Failure to follow these instructions can result in injury or equipment damage.**

## **NOTICE**

**NOTICE** is used to address practices not related to physical injury. The safety alert symbol shall not be used with this type of safety message.

**Failure to follow these instructions can result in equipment damage.**

## Please Note

Electrical equipment should only be installed, operated, serviced, and maintained by qualified personnel. No responsibility is assumed by Schneider Electric for any consequences arising out of the use of this material.

A qualified person is one who has skills and knowledge related to the construction, installation, and operation of electrical equipment and has received safety training to recognize and avoid the hazards involved.

## Electromagnetic Compatibility

### **NOTICE**

#### **RISK OF ELECTROMAGNETIC DISTURBANCE**

This is a product category C3 UPS product. In a residential environment, this product may cause radio interference, in which case the user may be required to take additional measures.

**Failure to follow these instructions can result in equipment damage.**

## Safety Precautions

### **⚠ DANGER**

#### **HAZARD OF ELECTRIC SHOCK, EXPLOSION, OR ARC FLASH**

All safety instructions in this document must be read, understood and followed.

**Failure to follow these instructions will result in death or serious injury.**

### **⚠ DANGER**

#### **HAZARD OF ELECTRIC SHOCK, EXPLOSION, OR ARC FLASH**

Read all instructions in the Installation Manual before installing or working on this UPS system.

**Failure to follow these instructions will result in death or serious injury.**

### **⚠ DANGER**

#### **HAZARD OF ELECTRIC SHOCK, EXPLOSION, OR ARC FLASH**

Do not install the UPS system until all construction work has been completed and the installation room has been cleaned.

**Failure to follow these instructions will result in death or serious injury.**

### **⚠ DANGER**

#### **HAZARD OF ELECTRIC SHOCK, EXPLOSION, OR ARC FLASH**

- The product must be installed according to the specifications and requirements as defined by Schneider Electric. It concerns in particular the external and internal protections (upstream breakers, battery breakers, cabling, etc.) and environmental requirements. No responsibility is assumed by Schneider Electric if these requirements are not respected.
- After the UPS system has been electrically wired, do not start up the system. Start-up must only be performed by Schneider Electric.

**Failure to follow these instructions will result in death or serious injury.**

## **⚠ DANGER**

### **HAZARD OF ELECTRIC SHOCK, EXPLOSION, OR ARC FLASH**

The UPS system must be installed according to local and national regulations. Install the UPS according to:

- IEC 60364 (including 60364-4-41 - protection against electric shock, 60364-4-42 - protection against thermal effect, and 60364-4-43 - protection against overcurrent), or
- NEC NFPA 70, or
- Canadian Electrical Code (C22.1, Part 1)

depending on which one of the standards apply in your local area.

**Failure to follow these instructions will result in death or serious injury.**

## **⚠ DANGER**

### **HAZARD OF ELECTRIC SHOCK, EXPLOSION, OR ARC FLASH**

- Install the UPS system in a temperature controlled indoor environment free of conductive contaminants and humidity.
- Install the UPS system on a non-flammable, level and solid surface (e.g. concrete) that can support the weight of the system.

**Failure to follow these instructions will result in death or serious injury.**

## **⚠ DANGER**

### **HAZARD OF ELECTRIC SHOCK, EXPLOSION, OR ARC FLASH**

The UPS is not designed for and must therefore not be installed in the following unusual operating environments:

- Damaging fumes
- Explosive mixtures of dust or gases, corrosive gases, or conductive or radiant heat from other sources
- Moisture, abrasive dust, steam or in an excessively damp environment
- Fungus, insects, vermin
- Salt-laden air or contaminated cooling refrigerant
- Pollution degree higher than 2 according to IEC 60664-1
- Exposure to abnormal vibrations, shocks, and tilting
- Exposure to direct sunlight, heat sources, or strong electromagnetic fields

**Failure to follow these instructions will result in death or serious injury.**

## **⚠ DANGER**

### **HAZARD OF ELECTRIC SHOCK, EXPLOSION, OR ARC FLASH**

Do not drill or cut holes for cables or conduits with the gland plates installed and do not drill or cut holes in close proximity to the UPS.

**Failure to follow these instructions will result in death or serious injury.**

## **⚠ WARNING**

### **HAZARD OF ARC FLASH**

Do not make mechanical changes to the product (including removal of cabinet parts or drilling/cutting of holes) that are not described in the Installation Manual.

**Failure to follow these instructions can result in death, serious injury, or equipment damage.**

**NOTICE****RISK OF OVERHEATING**

Respect the space requirements around the UPS system and do not cover the product's ventilation openings when the UPS system is in operation.

**Failure to follow these instructions can result in equipment damage.**

**NOTICE****RISK OF EQUIPMENT DAMAGE**

Do not connect the UPS output to regenerative load systems including photovoltaic systems and speed drives.

**Failure to follow these instructions can result in equipment damage.**

## Additional Safety Precautions After Installation

** DANGER****HAZARD OF ELECTRIC SHOCK, EXPLOSION, OR ARC FLASH**

Do not install the UPS system until all construction work has been completed and the installation room has been cleaned. If additional construction work is needed in the installation room after this product has been installed, turn off the product and cover the product with the protective packaging bag the product was delivered in.

**Failure to follow these instructions will result in death or serious injury.**

## Electrical Safety

### **⚠ DANGER**

#### **HAZARD OF ELECTRIC SHOCK, EXPLOSION, OR ARC FLASH**

- Electrical equipment must be installed, operated, serviced, and maintained only by qualified personnel.
- Apply appropriate personal protective equipment (PPE) and follow safe electrical work practices.
- Turn off all power supplying the UPS system before working on or inside the equipment.
- Before working on the UPS system, check for hazardous voltage between all terminals including the protective earth.
- The UPS contains an internal energy source. Hazardous voltage can be present even when disconnected from the mains supply. Before installing or servicing the UPS system, ensure that the units are OFF and that mains and batteries are disconnected. Wait five minutes before opening the UPS to allow the capacitors to discharge.
- A disconnection device (e.g. disconnection circuit breaker or switch) must be installed to enable isolation of the system from upstream power sources in accordance with local regulations. The disconnection device must be easily accessible and visible.
- The UPS must be properly earthed/grounded and due to a high leakage current, the earthing/grounding conductor must be connected first.

**Failure to follow these instructions will result in death or serious injury.**

### **⚠ DANGER**

#### **HAZARD OF ELECTRIC SHOCK, EXPLOSION, OR ARC FLASH**

In systems where backfeed protection is not part of the standard design, an automatic isolation device (backfeed protection option or other device meeting the requirements of IEC/EN 62040-1 or UL1778 5th Edition – depending on which of the two standards apply to your local area) must be installed to prevent hazardous voltage or energy at the input terminals of the isolation device. The device must open within 15 seconds after the upstream power supply fails and must be rated according to the specifications.

**Failure to follow these instructions will result in death or serious injury.**

When the UPS input is connected through external isolators that, when opened, isolate the neutral or when the automatic backfeed isolation is provided external to the equipment or is connected to an IT power distribution system, a label must be fitted at the UPS input terminals, and on all primary power isolators installed remote from the UPS area and on external access points between such isolators and the UPS, by the user, displaying the following text (or equivalent in a language which is acceptable in the country in which the UPS system is installed):

### **⚠ DANGER**

#### **HAZARD OF ELECTRIC SHOCK, EXPLOSION, OR ARC FLASH**

Risk of Voltage Backfeed. Before working on this circuit: Isolate the UPS and check for hazardous voltage between all terminals including the protective earth.

**Failure to follow these instructions will result in death or serious injury.**

**⚠ CAUTION****RISK OF ELECTRICAL DISTURBANCE**

This product can cause a DC current in the PE conductor. Where a residual current-operated protective device (RCD) is used for protection against electrical shock, only an RCD of Type B is allowed on the supply side of this product.

**Failure to follow these instructions can result in injury or equipment damage.**

**Battery Safety****⚡⚠ DANGER****HAZARD OF ELECTRIC SHOCK, EXPLOSION, OR ARC FLASH**

- Battery circuit breakers must be installed according to the specifications and requirements as defined by Schneider Electric.
- Servicing of batteries must only be performed or supervised by qualified personnel knowledgeable of batteries and the required precautions. Keep unqualified personnel away from batteries.
- Disconnect charging source prior to connecting or disconnecting battery terminals.
- Do not dispose of batteries in a fire as they can explode.
- Do not open, alter, or mutilate batteries. Released electrolyte is harmful to the skin and eyes. It may be toxic.

**Failure to follow these instructions will result in death or serious injury.**

**⚡⚠ DANGER****HAZARD OF ELECTRIC SHOCK, EXPLOSION, OR ARC FLASH**

Batteries can present a risk of electric shock and high short-circuit current. The following precautions must be observed when working on batteries

- Remove watches, rings, or other metal objects.
- Use tools with insulated handles.
- Wear protective glasses, gloves and boots.
- Do not lay tools or metal parts on top of batteries.
- Disconnect the charging source prior to connecting or disconnecting battery terminals.
- Determine if the battery is inadvertently grounded. If inadvertently grounded, remove source from ground. Contact with any part of a grounded battery can result in electric shock. The likelihood of such shock can be reduced if such grounds are removed during installation and maintenance (applicable to equipment and remote battery supplies not having a grounded supply circuit).

**Failure to follow these instructions will result in death or serious injury.**

**⚡⚠ DANGER****HAZARD OF ELECTRIC SHOCK, EXPLOSION, OR ARC FLASH**

When replacing batteries, always replace with the same type and number of batteries or battery packs.

**Failure to follow these instructions will result in death or serious injury.**

## **▲ CAUTION**















### **RISK OF EQUIPMENT DAMAGE**

- Mount the batteries in the UPS system, but do not connect the batteries until the UPS system is ready to be powered up. The time duration from battery connection until the UPS system is powered up must not exceed 72 hours or 3 days.
- Batteries must not be stored more than six months due to the requirement of recharging. If the UPS system remains de-energized for a long period, we recommend that you energize the UPS system for a period of 24 hours at least once every month. This charges the batteries, thus avoiding irreversible damage.

**Failure to follow these instructions can result in injury or equipment damage.**

**NOTE:** Always follow the battery manufacturer's installation manual for battery installation and maintenance instructions.

# Symbols Used in the Product

	This is the earthing/ground symbol.
	This is the protective earth/equipment grounding conductor symbol.
	This is the direct current symbol. It is also referred to as DC.
	This is the alternating current symbol. It is also referred to as AC.
	This is the positive polarity symbol. It is used to identify the positive terminal(s) of equipment which is used with, or generates direct current.
	This is the negative polarity symbol. It is used to identify the negative terminal(s) of equipment which is used with, or generates direct current.
	This is the battery symbol.
	This is the static switch symbol. It is used to indicate switches that are designed to connect or disconnect the load to or from the supply respectively without the existence of moving parts.
	This is the AC/DC converter (rectifier) symbol. It is used to identify an AC/DC converter (rectifier) and, in case of plug-in devices, to identify the relevant receptacles.
	This is the DC/AC converter (inverter) symbol. It is used to identify an DC/AC converter (inverter) and, in case of plug-in devices, to identify the relevant receptacles.
	This is the input symbol. It is used to identify an input terminal when it is necessary to distinguish between inputs and outputs.
	This is the output symbol. It is used to identify an output terminal when it is necessary to distinguish between inputs and outputs.
	This is the switch disconnecter symbol. It is used to identify the disconnecting device in the form of switch that protects the equipment from short circuit or heavy load current. It opens the circuits once the current flow crosses its maximum limit.
	This is the circuit breaker symbol. It is used to identify the disconnecting device in the form of circuit breaker that protects the equipment from short circuit or heavy load current. It opens the circuits once the current flow crosses its maximum limit.

# Specifications

## Specifications for 50 kW UPS

	Voltage (V)	380	400	415
<b>Input</b>	Connections	L1, L2, L3, N, PE (single mains) L1, L2, L3, PE (dual mains)		
	Input voltage range at full load (V) <sup>1</sup>	304-456	320-460	332-477
	Frequency (Hz)	40-70		
	Nominal input current (A)	80	76	74
	Maximum input current (A)	100	95	95
	Total harmonic distortion (THDI)	1% (linear load) 3% (non-linear load)		
	Input power factor	> 0.99 (full load)		
	Maximum short circuit rating	Rated conditional short-circuit current I <sub>cc</sub> = 35 kA Device: Refer to Required Upstream Protection, page 23.		
	Ramp-in	Programmable and adaptive 1-40 seconds		
	Protection	Built-in backfeed protection and fuses		
<b>Bypass</b>	Connections	L1, L2, L3, N, PE		
	Minimum bypass voltage (V)	342	360	374
	Maximum bypass voltage (V)	418	440	457
	Frequency (Hz)	50 or 60		
	Frequency range (Hz)	±1 Hz, ±3 Hz, ±10 Hz (user selectable)		
	Nominal bypass current (A)	78	74	71
	Maximum short circuit rating	Rated conditional short-circuit current I <sub>cc</sub> = 35 kA Device: Refer to Required Upstream Protection, page 23.		
	Protection	Dry contact signal for backfeed protection		
<b>Output</b>	Connections	L1, L2, L3, N, PE		
	Output voltage regulation	±1% (symmetrical load) ±3% (asymmetrical load)		
	Overload capacity	≤125% for 10 minutes; ≤150% for 1 minute (normal operation) ≤110% continuous; ≤125% for 10 minutes; ≤150% for 1 minute (bypass operation) ≤125% for 1 minute; ≤150% for 1 second (battery operation)		
	Output power factor	1		
	Nominal output current (A)	76	73	70
	Total harmonic distortion (THDU)	1% (linear load) 3% (non-linear load)		
	Output frequency (Hz)	50/60 Hz bypass synchronized 50/60 Hz ± 0.1% free-running		
	Slew rate (Hz/sec)	Programmable to 0.25, 0.5, 1, 2, 4, 6 Hz/second		
	Output performance classification (according to IEC/ EN62040-3)	VFI-SS-11		
	Load power factor	0.7 leading to 0.7 lagging without derating		
	Load crest factor	2.5		
Output short circuit current (inverter)	2.2-2.3 I <sub>n</sub>			

1. Measured at 30 °C

	<b>Voltage (V)</b>	<b>380</b>	<b>400</b>	<b>415</b>
<b>Battery</b>	Charging power in % of output power	1-60%		
	Maximum charging power (kW)	30		
	Nominal battery voltage (VDC)	480 to 576		
	Nominal float voltage (VDC)	545 to 654		
	End of discharge voltage (full load) (VDC)	384 to 461		
	Temperature compensation (per cell)	-3.3 mV/°C/cell for T ≥ 25 °C 0 mV/°C/cell for T < 25 °C		
	Battery current at full load and nominal battery voltage (A)	111		
	Battery current at full load and minimum battery voltage (A)	130		
	Ripple current	< 5% C20 (5-minute runtime)		
	Battery test	Manual/automatic (selectable)		
	Maximum short circuit rating	25 kA		

## Specifications for 100 kW UPS

	Voltage (V)	380	400	415
Input	Connections	L1, L2, L3, N, PE (single mains) L1, L2, L3, PE (dual mains)		
	Input voltage range of full load (V) <sup>2</sup>	304-456	320-460	332-477
	Frequency (Hz)	40-70		
	Nominal input current (A)	160	152	147
	Maximum input current (A)	200	190	190
	Total harmonic distortion (THDI)	< 3% for linear loads		
	Input power factor	> 0.99 (full load)		
	Maximum short circuit rating	Rated conditional short-circuit current I <sub>cc</sub> = 35 kA Device: Refer to Required Upstream Protection, page 23.		
	Ramp-in	Programmable and adaptive 1-40 seconds		
	Protection	Built-in backfeed protection and fuses		
Bypass	Connections	L1, L2, L3, N, PE		
	Minimum bypass voltage (V)	342	360	374
	Maximum bypass voltage (V)	418	440	457
	Frequency (Hz)	50 or 60		
	Frequency range (Hz)	±1 Hz, ±3 Hz, ±10 Hz (user selectable)		
	Nominal bypass current (A)	155	147	142
	Maximum short circuit rating	Rated conditional short-circuit current I <sub>cc</sub> = 35 kA Device: Refer to Required Upstream Protection, page 23.		
	Protection	Dry contact signal for backfeed protection		
Output	Connections	L1, L2, L3, N, PE		
	Output voltage regulation	±1% (symmetrical load) ±3% (asymmetrical load)		
	Overload capacity	≤125% for 10 minutes; ≤150% for 1 minute (normal operation) ≤110% continuous; ≤125% for 10 minutes; ≤150% for 1 minute (bypass operation) ≤125% for 1 minute; ≤150% for 1 second (battery operation)		
	Output power factor	1		
	Nominal output current (A)	152	145	140
	Total harmonic distortion (THDU)	1% (linear load) 5% (non-linear load)		
	Output frequency (Hz)	50/60 Hz bypass synchronized 50/60 Hz ± 0.1% free-running		
	Slew rate (Hz/sec)	Programmable to 0.25, 0.5, 1, 2, 4, 6 Hz/second		
	Output performance classification (according to IEC/ EN62040-3)	VFI-SS-11		
	Load power factor	0.7 leading to 0.7 lagging without derating		
	Load crest factor	2.5		
Output short circuit current (inverter)	2.2-2.3 I <sub>n</sub>			

2. Measured at 30 °C

	<b>Voltage (V)</b>	<b>380</b>	<b>400</b>	<b>415</b>
<b>Battery</b>	Charging power in % of output power	1-60%		
	Maximum charging power (kW)	60		
	Nominal battery voltage (VDC)	480 to 576		
	Nominal float voltage (VDC)	545 to 654		
	End of discharge voltage (full load) (VDC)	384 to 461		
	Temperature compensation (per cell)	-3.3 mV/°C/cell for T ≥ 25 °C 0 mV/°C/cell for T < 25 °C		
	Battery current at full load and nominal battery voltage (A)	222		
	Battery current at full load and minimum battery voltage (A)	260		
	Ripple current	< 5% C20 (5-minute runtime)		
	Battery test	Manual/automatic (selectable)		
	Maximum short circuit rating	25 kA		

## Specifications for 150 kW UPS

	Voltage (V)	380	400	415
Input	Connections	L1, L2, L3, N, PE (single mains) L1, L2, L3, PE (dual mains)		
	Input voltage range at full load (V) <sup>3</sup>	304-456	320-460	332-477
	Frequency (Hz)	40-70		
	Nominal input current (A)	240	228	220
	Maximum input current (A)	300	285	285
	Total harmonic distortion (THDI)	< 3% for linear loads		
	Input power factor	> 0.99 (full load)		
	Maximum short circuit rating	Rated conditional short-circuit current I <sub>cc</sub> = 35 kA Device: Refer to Required Upstream Protection, page 23.		
	Ramp-in	Programmable and adaptive 1-40 seconds		
	Protection	Built-in backfeed protection and fuses		
Bypass	Connections	L1, L2, L3, N, PE		
	Minimum bypass voltage (V)	342	360	374
	Maximum bypass voltage (V)	418	440	457
	Frequency (Hz)	50 or 60		
	Frequency range (Hz)	±1 Hz, ±3 Hz, ±10 Hz (user selectable)		
	Nominal bypass current (A)	232	220	212
	Maximum short circuit rating	Rated conditional short-circuit current I <sub>cc</sub> = 35 kA Device: Refer to Required Upstream Protection, page 23.		
	Protection	Dry contact signal for backfeed protection		
Output	Connections	L1, L2, L3, N, PE		
	Output voltage regulation	±1% (symmetrical load) ±3% (asymmetrical load)		
	Overload capacity	≤125% for 10 minutes; ≤150% for 1 minute (normal operation) ≤110% continuous; ≤125% for 10 minutes; ≤150% for 1 minute (bypass operation) ≤125% for 1 minute; ≤150% for 1 second (battery operation)		
	Output power factor	1		
	Nominal output current (A)	228	217	209
	Total harmonic distortion (THDU)	1% (linear load) 3% (non-linear load)		
	Output frequency (Hz)	50/60 Hz bypass synchronized 50/60 Hz ± 0.1% free-running		
	Slew rate (Hz/sec)	Programmable to 0.25, 0.5, 1, 2, 4, 6 Hz/second		
	Output performance classification (according to IEC/ EN62040-3)	VFI-SS-11		
	Load power factor	0.7 leading to 0.7 lagging without derating		
	Load crest factor	2.5		
Output short circuit current (inverter)	2.2-2.3 In			

3. Measured at 30 °C

	<b>Voltage (V)</b>	<b>380</b>	<b>400</b>	<b>415</b>
<b>Battery</b>	Charging power in % of output power	1-60%		
	Maximum charging power (kW)	90		
	Nominal battery voltage (VDC)	480 to 576		
	Nominal float voltage (VDC)	545 to 654		
	End of discharge voltage (full load) (VDC)	384 to 461		
	Temperature compensation (per cell)	-3.3 mV/°C/cell for T ≥ 25 °C 0 mV/°C/cell for T < 25 °C		
	Battery current at full load and nominal battery voltage (A)	333		
	Battery current at full load and minimum battery voltage (A)	390		
	Ripple current	< 5% C20 (5-minute runtime)		
	Battery test	Manual/automatic (selectable)		
	Maximum short circuit rating	25 kA		

## Specifications for 200 kW UPS

	Voltage (V)	380	400	415
Input	Connections	L1, L2, L3, N, PE (single mains) L1, L2, L3, PE (dual mains)		
	Input voltage range at full load (V) <sup>4</sup>	304-456	320-460	332-477
	Frequency (Hz)	40-70		
	Nominal input current (A)	320	304	293
	Maximum input current (A)	400	380	380
	Total harmonic distortion (THDI)	< 3% for linear loads		
	Input power factor	> 0.99 (full load)		
	Maximum short circuit rating	Rated conditional short-circuit current I <sub>cc</sub> = 35 kA Device: Refer to Required Upstream Protection, page 23.		
	Ramp-in	Programmable and adaptive 1-40 seconds		
	Protection	Built-in backfeed protection and fuses		
Bypass	Connections	L1, L2, L3, N, PE		
	Minimum bypass voltage (V)	342	360	374
	Maximum bypass voltage (V)	418	440	457
	Frequency (Hz)	50 or 60		
	Frequency range (Hz)	±1 Hz, ±3 Hz, ±10 Hz (user selectable)		
	Nominal bypass current (A)	309	294	283
	Maximum short circuit rating	Rated conditional short-circuit current I <sub>cc</sub> = 35 kA Device: Refer to Required Upstream Protection, page 23.		
	Protection	Dry contact signal for backfeed protection		
Output	Connections	L1, L2, L3, N, PE		
	Output voltage regulation	±1% (symmetrical load) ±3% (asymmetrical load)		
	Overload capacity	≤125% for 10 minutes; ≤150% for 1 minute (normal operation) ≤110% continuous; ≤125% for 10 minutes; ≤150% for 1 minute (bypass operation) ≤125% for 1 minute; ≤150% for 1 second (battery operation)		
	Output power factor	1		
	Nominal output current (A)	304	289	279
	Total harmonic distortion (THDU)	1% (linear load) 3% (non-linear load)		
	Output frequency (Hz)	50/60 Hz bypass synchronized 50/60 Hz ± 0.1% free-running		
	Slew rate (Hz/sec)	Programmable to 0.25, 0.5, 1, 2, 4, 6 Hz/second		
	Output performance classification (according to IEC/ EN62040-3)	VFI-SS-11		
	Load power factor	0.7 leading to 0.7 lagging without derating		
	Load crest factor	2.5		
Output short circuit current (inverter)	2.2-2.3 In			

4. Measured at 30 °C

	<b>Voltage (V)</b>	<b>380</b>	<b>400</b>	<b>415</b>
<b>Battery</b>	Charging power in % of output power	1-60%		
	Maximum charging power (kW)	120		
	Nominal battery voltage (VDC)	480 to 576		
	Nominal float voltage (VDC)	545 to 654		
	End of discharge voltage (full load) (VDC)	384 to 461		
	Temperature compensation (per cell)	-3.3 mV/°C/cell for T ≥ 25 °C 0 mV/°C/cell for T < 25 °C		
	Battery current at full load and nominal battery voltage (A)	444		
	Battery current at full load and minimum battery voltage (A)	520		
	Ripple current	< 5% C20 (5-minute runtime)		
	Battery test	Manual/automatic (selectable)		
	Maximum short circuit rating	25 kA		

# Specifications for 250 kW UPS

	Voltage (V)	380	400	415
Input	Connections	L1, L2, L3, N, PE (single mains) L1, L2, L3, PE (dual mains)		
	Input voltage range at full load (V) <sup>5</sup>	304-456	320-460	332-477
	Frequency (Hz)	40-70		
	Nominal input current (A)	400	380	367
	Maximum input current (A)	500	475	475
	Total harmonic distortion (THDI)	1% (linear load) 3% (non-linear load)		
	Input power factor	> 0.99 (full load)		
	Maximum short circuit rating	Rated conditional short-circuit current I <sub>cc</sub> = 35 kA Device: Refer to Required Upstream Protection, page 23.		
	Ramp-in	Programmable and adaptive 1-40 seconds		
	Protection	Built-in backfeed protection and fuses		
Bypass	Connections	L1, L2, L3, N, PE		
	Minimum bypass voltage (V)	342	360	374
	Maximum bypass voltage (V)	418	440	457
	Frequency (Hz)	50 or 60		
	Frequency range (Hz)	±1 Hz, ±3 Hz, ±10 Hz (user selectable)		
	Nominal bypass current (A)	386	367	354
	Maximum short circuit rating	Rated conditional short-circuit current I <sub>cc</sub> = 35 kA Device: Refer to Required Upstream Protection, page 23.		
	Protection	Dry contact signal for backfeed protection		
Output	Connections	L1, L2, L3, N, PE		
	Output voltage regulation	±1% (symmetrical load) ±3% (asymmetrical load)		
	Overload capacity	≤125% for 10 minutes; ≤150% for 1 minute (normal operation) ≤110% continuous; ≤125% for 10 minutes; ≤150% for 1 minute (bypass operation) ≤125% for 1 minute; ≤150% for 1 second (battery operation)		
	Output power factor	1		
	Nominal output current (A)	380	361	348
	Total harmonic distortion (THDU)	1% (linear load) 3% (non-linear load)		
	Output frequency (Hz)	50/60 Hz bypass synchronized 50/60 Hz ± 0.1% free-running		
	Slew rate (Hz/sec)	Programmable to 0.25, 0.5, 1, 2, 4, 6 Hz/second		
	Output performance classification (according to IEC/ EN62040-3)	VFI-SS-11		
	Load power factor	0.7 leading to 0.7 lagging without derating		
	Load crest factor	2.5		
	Output short circuit current (inverter)	2.2-2.3 I <sub>n</sub>		

5. Measured at 30 °C

	<b>Voltage (V)</b>	<b>380</b>	<b>400</b>	<b>415</b>
<b>Battery</b>	Charging power in % of output power	1-60%		
	Maximum charging power (kW)	150		
	Nominal battery voltage (VDC)	480 to 576		
	Nominal float voltage (VDC)	545 to 654		
	End of discharge voltage (full load) (VDC)	384 to 461		
	Temperature compensation (per cell)	-3.3 mV/°C/cell for T ≥ 25 °C 0 mV/°C/cell for T < 25 °C		
	Battery current at full load and nominal battery voltage (A)	555		
	Battery current at full load and minimum battery voltage (A)	650		
	Ripple current	< 5% C20 (5-minute runtime)		
	Battery test	Manual/automatic (selectable)		
	Maximum short circuit rating	25 kA		

## Required Upstream Protection

**NOTE:** For local directives which require 4-pole circuit breakers: If neutral conductor is expected to carry a high current, due to line-neutral non-linear load, the circuit breaker must be rated according to expected neutral current.

**⚡ ⚠ DANGER**

**HAZARD OF ELECTRIC SHOCK, EXPLOSION, OR ARC FLASH**

The required breakers listed below must be used in the upstream protection.

**Failure to follow these instructions will result in death or serious injury.**

UPS rating	50 kW		100 kW	
	Input	Bypass	Input	Bypass
Breaker type	NSX100H TM100D (C10H3TM100)	NSX100H TM80D (C10H3TM080)	NSX250H TM200 (C25H3TM200)	NSX160H TM160 (C16H3TM160)
Io	100	80	200	160
I <sub>r</sub>	100	80	200	160
I <sub>sd</sub>	800 (fixed)	640 (fixed)	5 - 10	1250 (fixed)

UPS rating	150 kW		200 kW	
	Input	Bypass	Input	Bypass
Breaker type	NSX400H MiC.2.3 (C40H32D400)	NSX250H TM250 (C25H3TM250)	NSX400H MiC.2.3 (C40H32D400)	NSX400H MiC.2.3 (C40H32D400)
Io	320	250	400	320
I <sub>r</sub>	0.95	250	1	1
I <sub>sd</sub>	1.5 - 10	5 - 10	1.5 - 10	1.5 - 10

UPS rating	250 kW	
	Input	Bypass
Breaker type	NSX630H MiC.2.3 (C63H32D630)	NSX400H MiC.2.3 (C40H32D400)
Io	500	400
I <sub>r</sub>	1	1
I <sub>sd</sub>	1.5 - 10	1.5 - 10

## Recommended Cables Sizes

### DANGER

#### HAZARD OF ELECTRIC SHOCK, EXPLOSION, OR ARC FLASH

All wiring must comply with all applicable national and/or electrical codes. The maximum allowable cable size is 185 mm<sup>2</sup>.

**Failure to follow these instructions will result in death or serious injury.**

**NOTE:** Overcurrent protection is to be provided by external devices..

Cable sizes in this manual are based on table A.52-5 of IEC 60364-5-52 with the following assertions:

- 90 °C conductors
- An ambient temperature of 30 °C
- Use of copper conductors
- Installation method C

PE size is based on table 54.3 of IEC 60364-5-54.

If the ambient temperature is greater than 30 °C, larger conductors are to be used in accordance with the correction factors of the IEC.

**NOTE:** Battery cables are sized according to 40 battery blocks. Contact Schneider Electric for cable sizes for systems with more than 40 battery blocks.

**NOTE:** It is recommended to use the provided screws to connect cables for clients.

### 50 kW UPS

	Cable size per phase (mm <sup>2</sup> )	Neutral cable size (mm <sup>2</sup> )	PE cable size (mm <sup>2</sup> )
Input	25	35	16
Bypass	16	35	16
Output	16	35	16
Battery	35	35	16

### 100 kW UPS

	Cable size per phase (mm <sup>2</sup> )	Neutral cable size (mm <sup>2</sup> )	PE cable size (mm <sup>2</sup> )
Input	70	2 x 70	35
Bypass	70	2 x 70	35
Output	70	2 x 70	35
Battery	95	95	50

### 150 kW UPS

	Cable size per phase (mm <sup>2</sup> )	Neutral cable size (mm <sup>2</sup> )	PE cable size (mm <sup>2</sup> )
Input	120	2 x 70	70
Bypass	120	2 x 70	70

	Cable size per phase (mm <sup>2</sup> )	Neutral cable size (mm <sup>2</sup> )	PE cable size (mm <sup>2</sup> )
Output	120	2 x 70	70
Battery	2 x 70	2 x 70	70

## 200 kW UPS

	Cable size per phase (mm <sup>2</sup> )	Neutral cable size (mm <sup>2</sup> )	PE cable size (mm <sup>2</sup> )
Input	2 x 95	2 x 95	95
Bypass	2 x 70	2 x 70	70
Output	2 x 70	2 x 70	70
Battery	2 x 120	2 x 120	120

## 250 kW UPS

	Cable size per phase (mm <sup>2</sup> )	Neutral cable size (mm <sup>2</sup> )	PE cable size (mm <sup>2</sup> )
Input	2 x 120	2 x 120	120
Bypass	2 x 95	2 x 95	95
Output	2 x 95	2 x 95	95
Battery	2 x 150	2 x 150	150

## Recommended Bolt and Lug Sizes

### Copper

Cable size (mm <sup>2</sup> )	Bolt size	Cable lug type
16	M10x40 mm	TLK 16-10
25	M10x40 mm	TLK 25-10
35	M10x40 mm	TLK 35-10
50	M10x40 mm	TLK 50-10
70	M10x40 mm	TLK 70-10
95	M10x40 mm	TLK 95-10
120	M10x40 mm	TLK 120-10
150	M10x40 mm	TLK 150-10
185	M10x40 mm	TLK 185-10

## Torque Specifications

Bolt size	Torque
M4	1.7 Nm
M6	5 Nm
M8	17.5 Nm

---

<b>Bolt size</b>	<b>Torque</b>
M10	30 Nm
M12	50 Nm

# Requirements for a Third Party Battery Solution

Battery breaker boxes from Schneider Electric are recommended for the battery interface. Please contact Schneider Electric for more information.

## Third Party Battery Breaker Requirements

**⚠️⚠️ DANGER**

**HAZARD OF ELECTRIC SHOCK, EXPLOSION, OR ARC FLASH**

- All selected battery breakers must be equipped with instantaneous trip functionality with an undervoltage release coil or a shunt trip release coil.
- Trip delay must be set to zero on all battery breakers.

**Failure to follow these instructions will result in death or serious injury.**

**NOTE:** There are more factors to consider when selecting a battery breaker than the requirements listed below. Please contact Schneider Electric for more information.

### Design Requirements for Battery Breaker

Battery breaker rated DC voltage > Normal battery voltage	The normal voltage of the battery configuration is defined as the highest nominal occurring battery voltage. This can be equivalent to the float voltage which may be defined as <b>number of battery blocks x number of cells x cell float voltage</b> .
Battery breaker rated DC current > Rated discharge battery current	This current is controlled by the UPS and must include maximum discharge current. This will typically be the current at the end of discharge (minimum operation DC voltage or in overload condition or a combination).
DC landings	Two DC landings for DC cables (DC+ and DC-) are required.
AUX switches for monitoring	One AUX switch must be installed in each battery breaker and connected to the UPS. The UPS can monitor up to four battery breakers.
Short-circuit breaking capability	The short-circuit breaking capability must be higher than the short-circuit DC current of the (largest) battery configuration.
Minimum trip current	The minimum short-circuit current to trip the battery breaker must match the (smallest) battery configuration, to make the breaker trip in case of a short circuit, up to the end of its life time.
Common battery solution	Individual battery breaker for each UPS in the parallel system.

## Guidance for Organizing Battery Cables

**NOTE:** For 3rd party batteries, use only high rate batteries for UPS applications.

**NOTE:** When the battery bank is placed remotely, the organizing of the cables is important to reduce voltage drop and inductance. The distance between the battery bank and the UPS must not exceed 200 m (656 ft). Contact Schneider Electric for installations with a longer distance.

**NOTE:** To minimize the risk of electromagnetic radiation, it is highly recommended to follow the below guidance and to use grounded metallic tray supports.

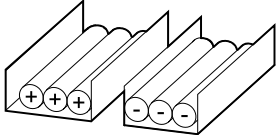
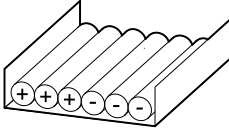
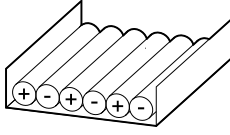
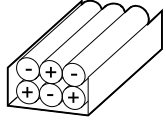
Cable Length				
<30 m	Not recommended	Acceptable	Recommended	Recommended
31–75 m	Not recommended	Not recommended	Acceptable	Recommended
76–150 m	Not recommended	Not recommended	Acceptable	Recommended
151–200 m	Not recommended	Not recommended	Not recommended	Recommended

## UPS Weights and Dimensions

### UPS with One Internal Switch

Type	Weight kg	Height mm	Width mm	Depth mm
50 kW	216	1991	600	850
50 kW with N+1 power module	244	1991	600	850
100 kW	244	1991	600	850
100 kW with N+1 power module	272	1991	600	850
150 kW	272	1991	600	850
150 kW with N+1 power module	300	1991	600	850
200 kW	300	1991	600	850
200 kW with N+1 power module	328	1991	600	850
250 kW	328	1991	600	850
250 kW with N+1 power module	356	1991	600	850

### UPS with Four Internal Switches

Type	Weight kg	Height mm	Width mm	Depth mm
50 kW	251	1991	600	850
50 kW with N+1 power module	279	1991	600	850
100 kW	279	1991	600	850
100 kW with N+1 power module	307	1991	600	850
150 kW	307	1991	600	850
150 kW with N+1 power module	335	1991	600	850
200 kW	335	1991	600	850
200 kW with N+1 power module	363	1991	600	850
250 kW	363	1991	600	850
250 kW with N+1 power module	391	1991	600	850

## Clearance

**NOTE:** Clearance dimensions are published for airflow and service access only. Consult with the local safety codes and standards for additional requirements in your local area.

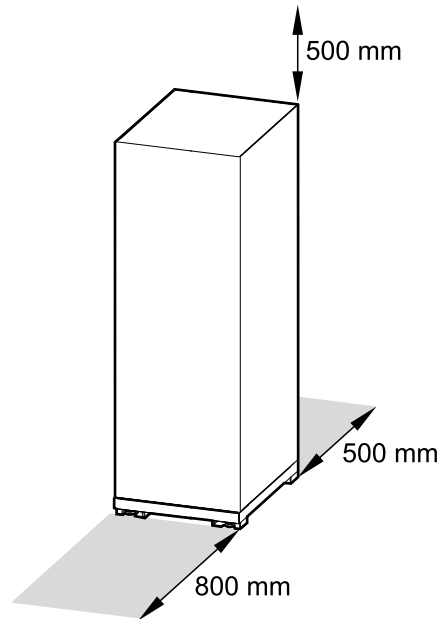

**NOTE:** 500 mm rear clearance is also required when the depth adapter is installed with the UPS.

## Environment

	Operating	Storage
Temperature	0 °C to 50 °C with load derating above 40 °C <sup>6</sup>	-25 °C to 55 °C
Relative humidity	0-95% non-condensing	0-95% non-condensing
Elevation	Designed for operation in 0-3000 m elevation.  Derating required from 1000-3000 m with forced air cooling: Up to 1000 m: 1.000 Up to 1500 m: 0.975 Up to 2000 m: 0.950 Up to 2500 m: 0.925 Up to 3000 m: 0.900	
Audible noise <sup>7</sup>	68 dB at 70% load  74 dB at 100% load	
Protection class	IP20	
Color	Black	

6. For temperatures between 40 °C and 50 °C, derate the load power rating to 75%.

7. Values are measured for the maximum configuration.

## Compliance

Safety	IEC 62040-1:2017, Edition 2.0, Uninterruptible power systems (UPS) – Part 1: Safety requirements
EMC	IEC 62040-2:2016, Edition 3.0, Uninterruptible power systems (UPS) – Part 2: Electromagnetic compatibility (EMC) requirements. IEC 62040-2:2005-10, Edition 2.0, Uninterruptible Power Systems (UPS) – Part 2: Electromagnetic compatibility (EMC) requirements
Performance	IEC 62040-3: 2021-03, Edition 3.0, Uninterruptible Power Systems (UPS) - Part 3: Method of specifying the performance and test requirements
Transportation	IEC TR 60721-4-2 Level 2M2
Pollution degree	2
Overvoltage category	III
Earthing system	TN-S, TN-C, TN-C-S
Protective class	I
Arc flash safety	IEC TR 61641: 2014 Edition 3.0

# Overview

## Single System Overview

UIB	Unit input breaker
SSIB	Static switch input breaker
UOB	Unit output breaker
IMB	Internal maintenance breaker
MBB	Maintenance bypass breaker
BB	Battery breaker

### Single System – Single Mains (One Internal Switch)

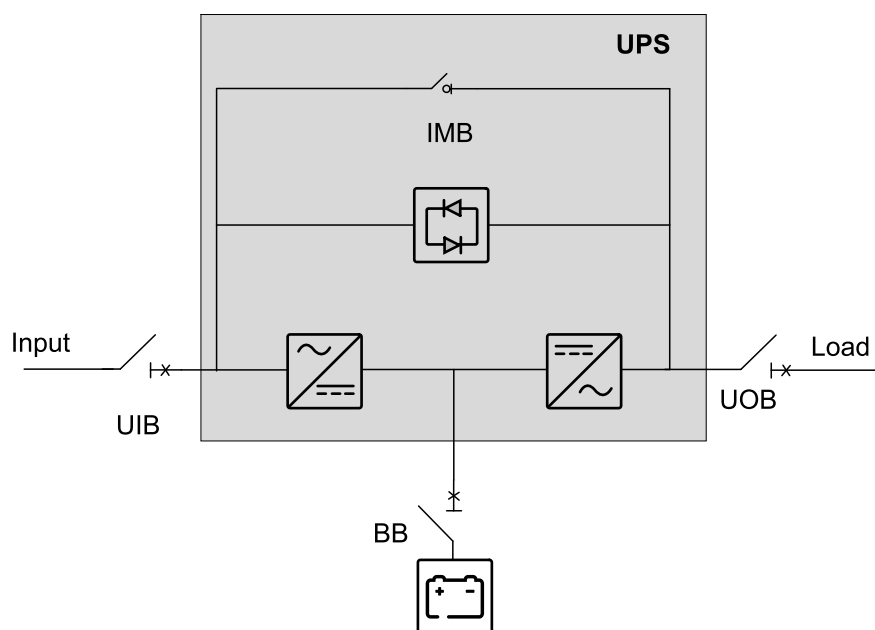

### Single System – Dual Mains (One Internal Switch)

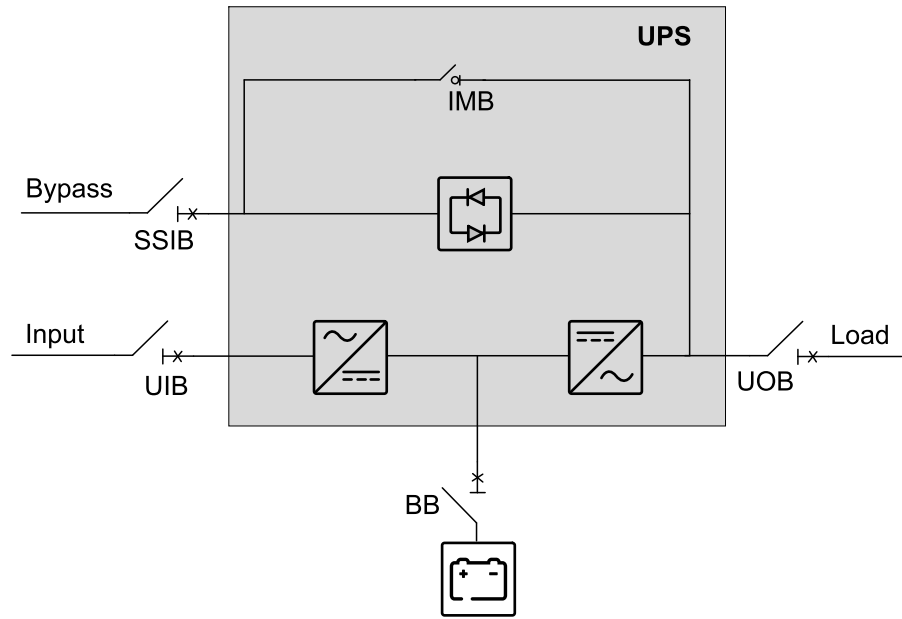

### Single System – Single Mains (Four Internal Switches)

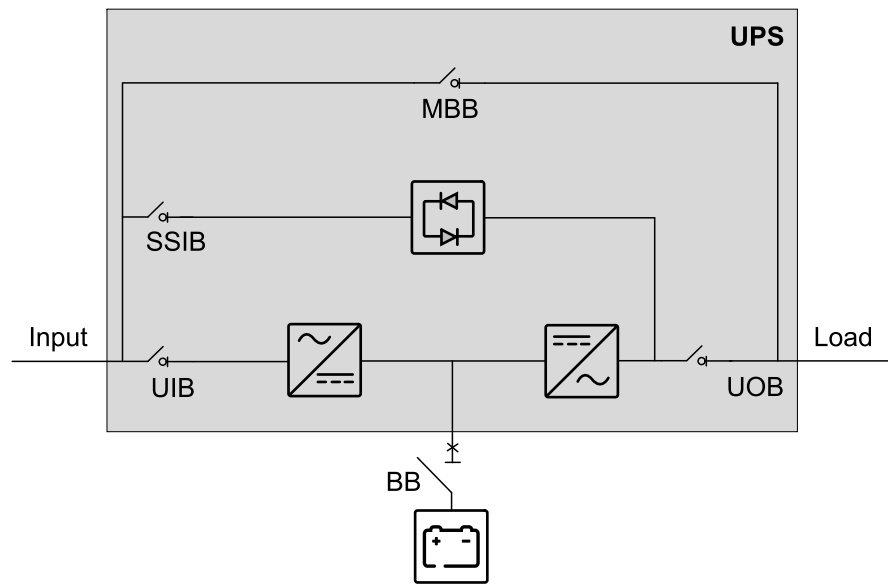

### Single System – Dual Mains (Four Internal Switches)

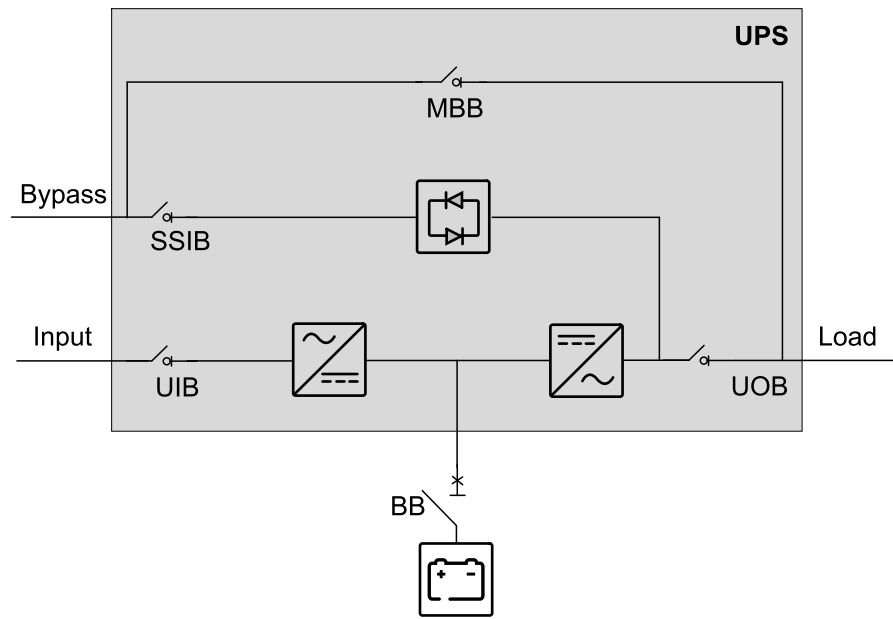

# Parallel System Overview

UIB	Unit input breaker
SSIB	Static switch input breaker
UOB	Unit output breaker
SIB	System isolation breaker
BIB	Bypass input breaker
MIB	Mains input breaker
BB	Battery breaker
IMB	Internal maintenance breaker
MBB	Maintenance bypass breaker
Ext. MBB	External maintenance bypass breaker

The UPS can support up to 4 UPSs in parallel for capacity and up to 3+1 UPSs in parallel for redundancy.

**NOTE:** In a parallel system, an external maintenance bypass breaker (Ext. MBB) must be provided and the internal maintenance breaker IMB and MBB (marked with an \* in the diagrams) must be padlocked in the open position.

**Parallel System – Single Mains (One Internal Switch)**

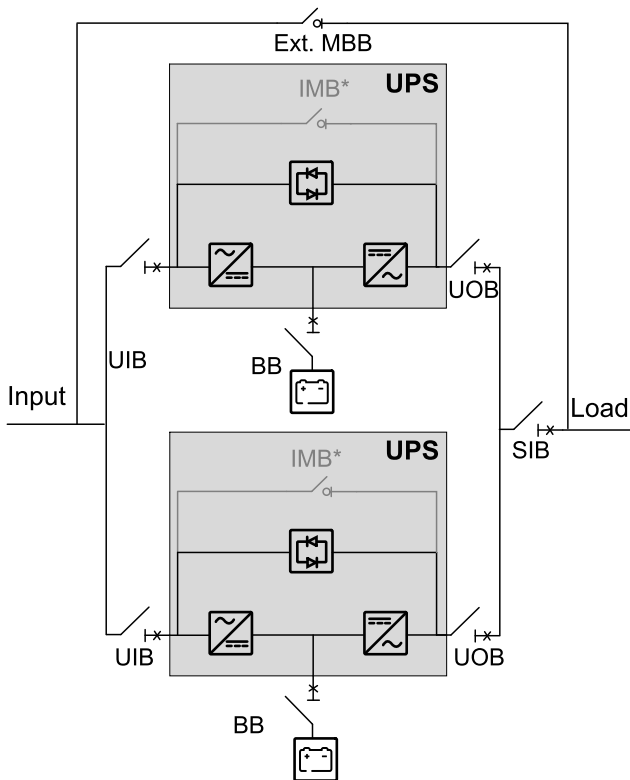

**Parallel System – Dual Mains (One Internal Switch)**

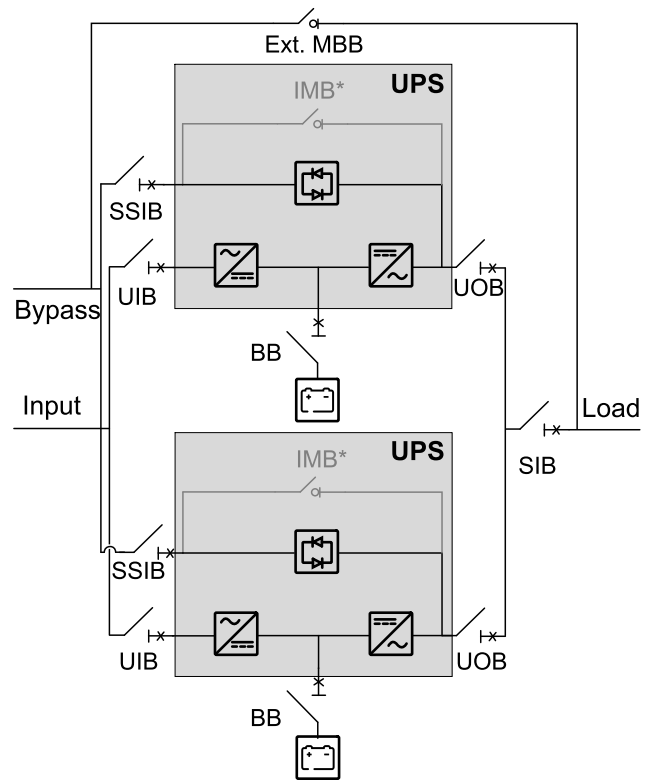

**Parallel System – Single Mains (Four Internal Switches)**

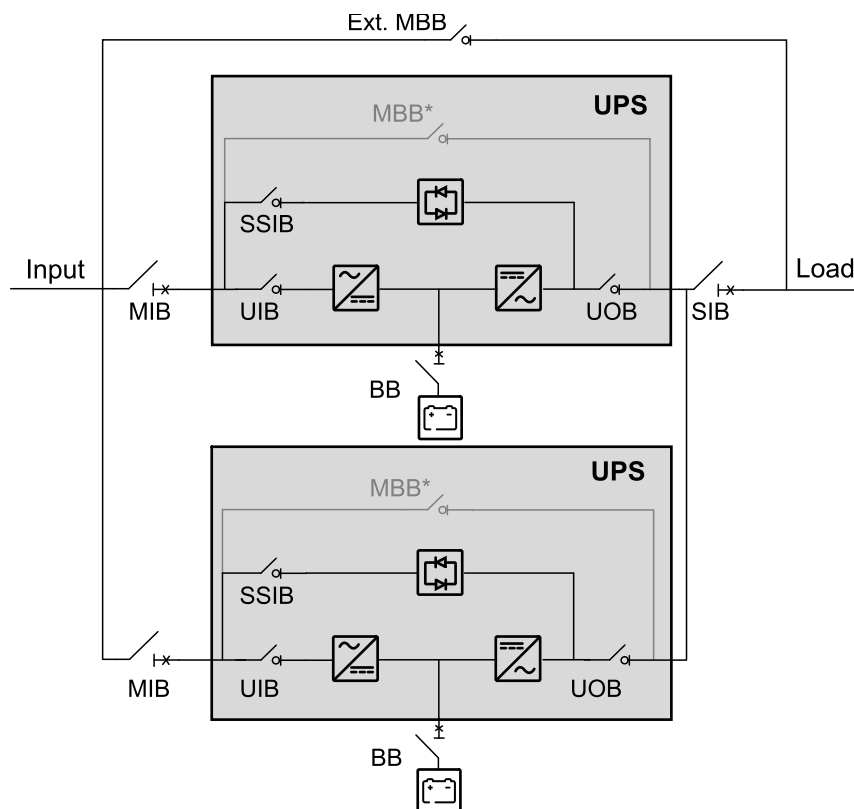

**Parallel System – Dual Mains (Four Internal Switches)**

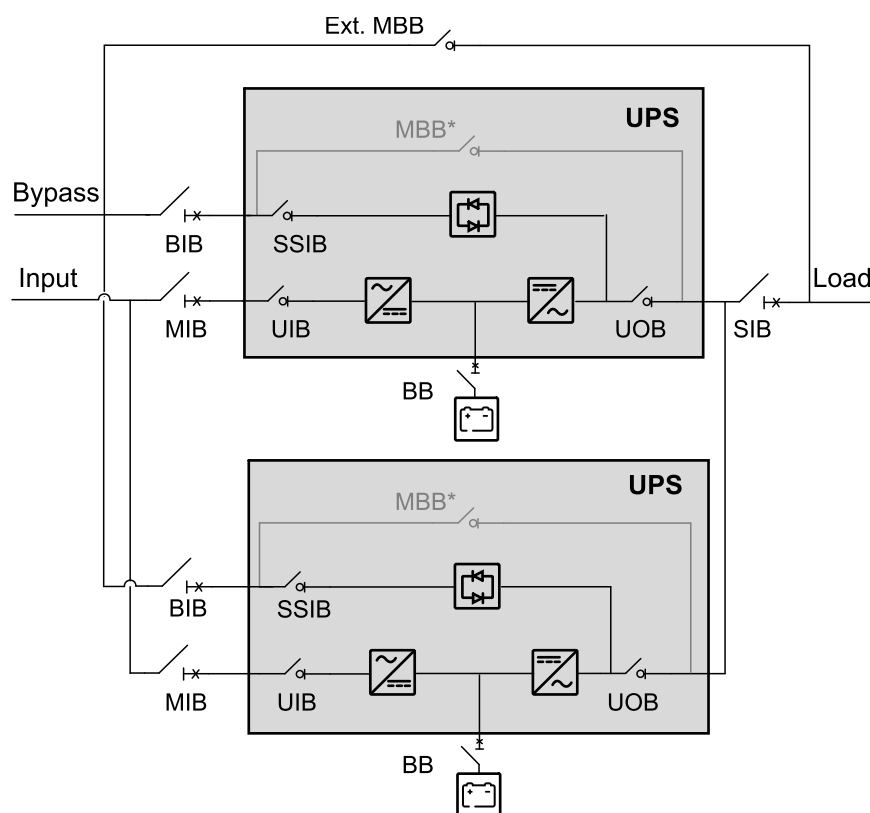

# Installation Procedure

## DANGER

### HAZARD OF ELECTRIC SHOCK, EXPLOSION, OR ARC FLASH

The UPS must be secured against movement. Perform one of the following actions/procedures once the UPS is in its final position:

- Reinstall the front transportation bracket on the UPS and mount it to the floor, OR
- Install the seismic anchoring kit.

**Failure to follow these instructions will result in death or serious injury.**

## WARNING

### TILTING HAZARD

The cabinet is top heavy - move with care and use ramps over uneven floors.

**Failure to follow these instructions can result in death, serious injury, or equipment damage.**

1. Perform one of the following procedures:
  - Without seismic anchoring: Position the UPS, page 39, or
  - With seismic anchoring: Install the Seismic Anchoring (Option), page 41.
2. Perform one of the following procedures:
  - Top cable entry: Prepare the UPS for Top Cable Entry, page 45, or
  - Bottom cable entry: Follow the installation manual provided with the bottom entry cabinet.
3. **Only for TN-C earthing system:** Prepare for TN-C Earthing System, page 49.
4. **Only for UPS with one internal switch:** Install the Neutral Disconnection Kit (Option), page 50.
5. Perform one of the following procedures:
  - Connect the Power Cables for the UPS with One Internal Switch, page 52, or
  - Connect the Power Cables for the UPS with Four Internal Switches, page 55.
6. Connect the Signal Cables, page 58.
7. Connect the Signal Cables from Switchgear and Third-Party Auxiliary Products, page 62.
8. Connect the Modbus Cables, page 65.
9. **Only for parallel system:** Connect the PBUS Cables, page 67.
10. Install the Power Module(s), page 68.
11. Final Installation, page 74.

## Position the UPS

### **⚠ ⚠ DANGER**

#### **HAZARD OF ELECTRIC SHOCK, EXPLOSION, OR ARC FLASH**

The UPS must be secured against movement. Once the UPS is in its final position, reinstall the front and rear transportation brackets on the UPS and mount them to the floor.

**Failure to follow these instructions will result in death or serious injury.**

1. Push the UPS into the final position.
2. Lower the front and rear feet on the UPS with a wrench until they connect with the floor. The casters must not have contact with the floor. Use a bubble-leveler to check that the UPS is level.
3. Reinstall the front transportation bracket on the UPS and mount it to the floor. Use appropriate hardware for the floor type – the hole diameter in the bracket is  $\varnothing 10$  mm. The requirement is M8 strength grade 8.8 hardware.

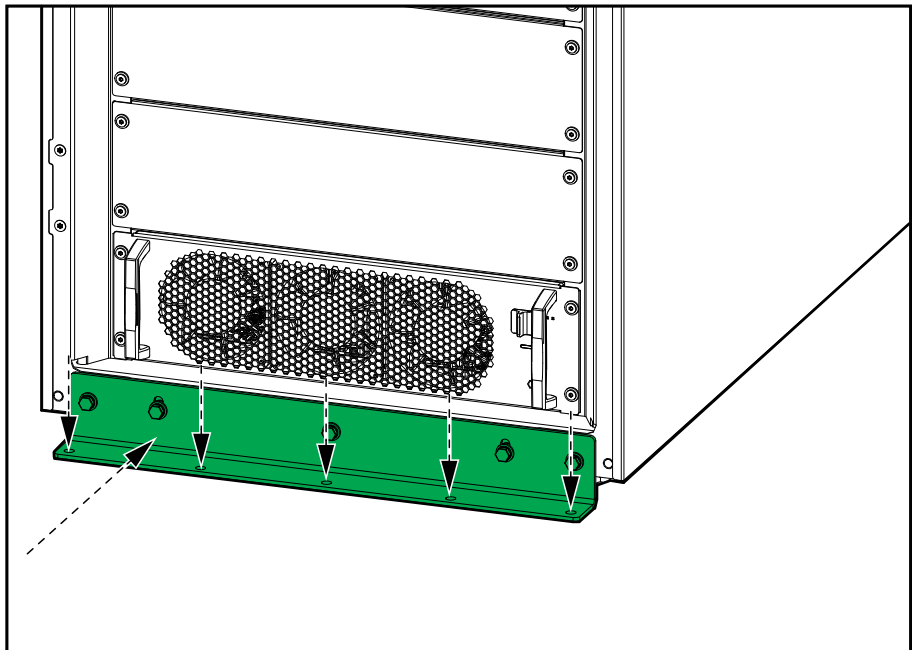

4. Reinstall the rear transportation bracket on the UPS and mount it to the floor. Use appropriate hardware for the floor type – the hole diameter in the bracket is  $\varnothing 10$  mm. The requirement is M8 strength grade 8.8 hardware.

#### Rear View

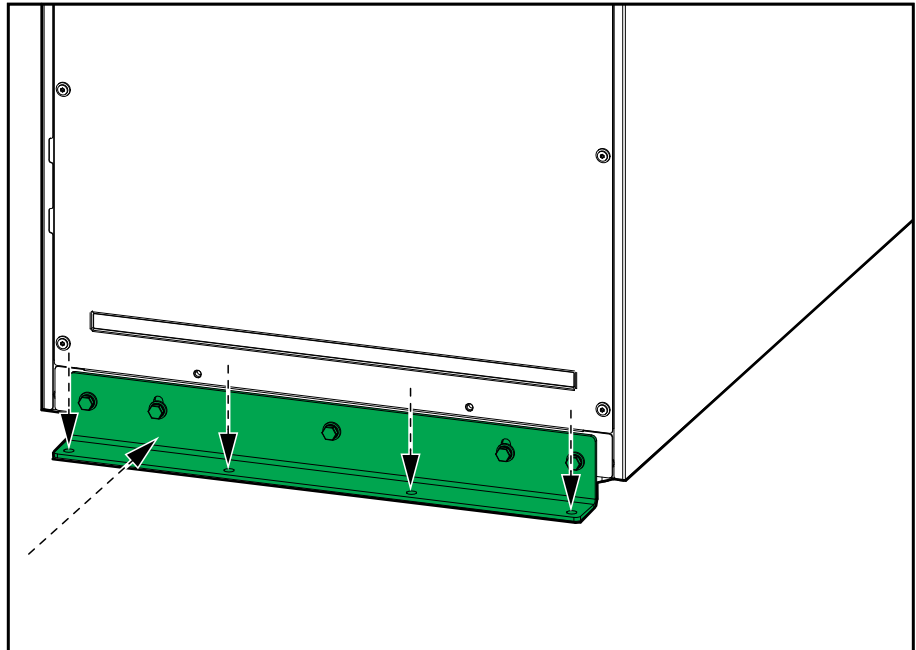

## Install the Seismic Anchoring (Option)

**NOTE:** Use the optional seismic kit SP3OPT005 for this procedure.

1. Push the UPS into the final position.
2. Install the rear anchoring bracket on the UPS with the provided M8 x 20 bolts.

**Option:** Use the shimming sheet (870-91123) for alignment with a two meter tall rack.

### Rear View (without Shimming Sheet)

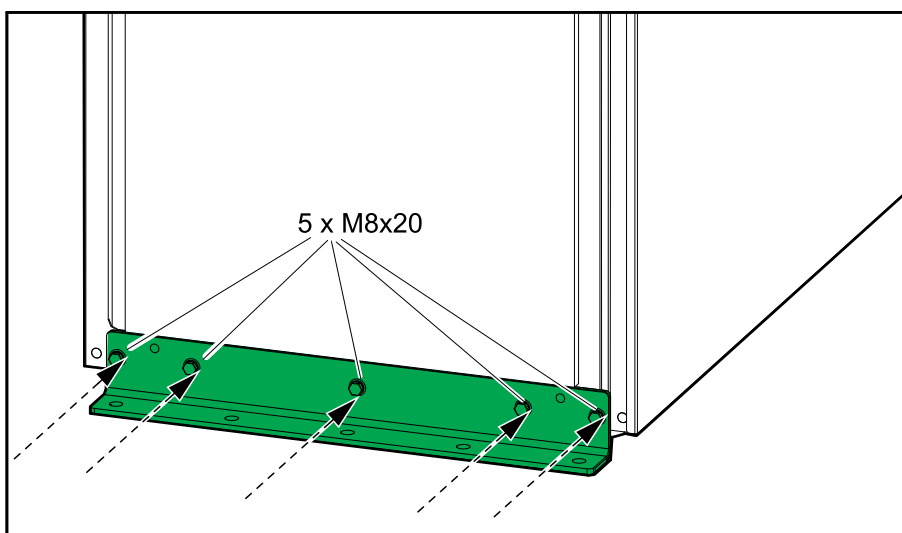

### Rear View (with Shimming Sheet)

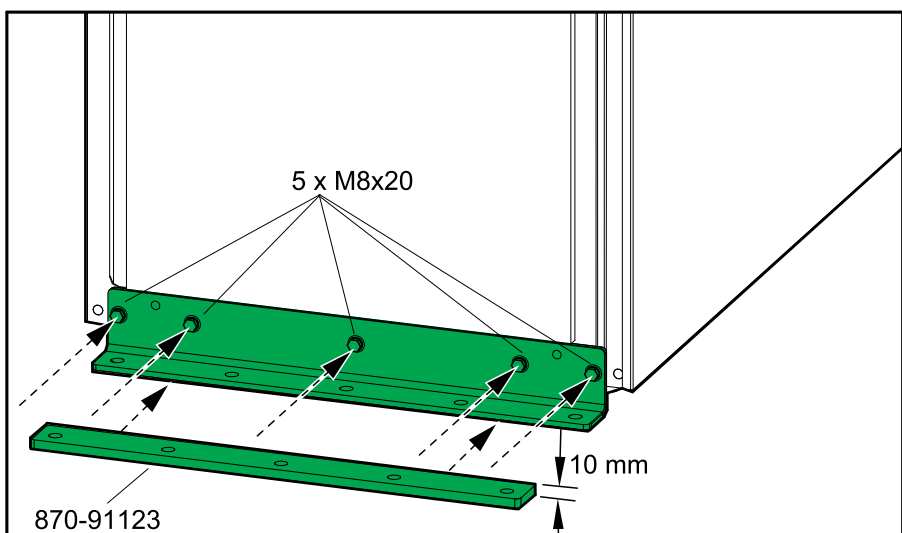

3. Mount the rear anchoring bracket to the floor. Use appropriate hardware for the floor type – the hole diameter in the rear anchors is  $\varnothing 14$  mm. The requirement is M12 strength grade 8.8 hardware.

**Front View (without Shimming Sheet)**

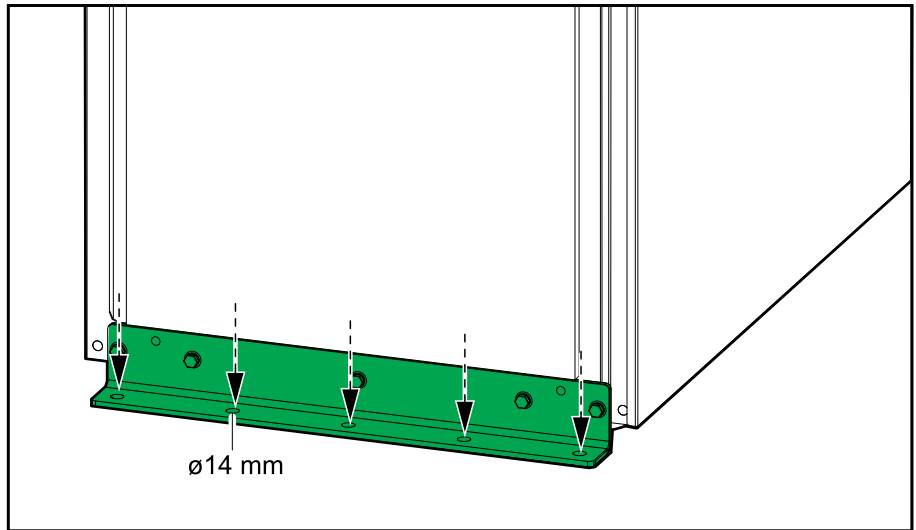

**Front View (with Shimming Sheet)**

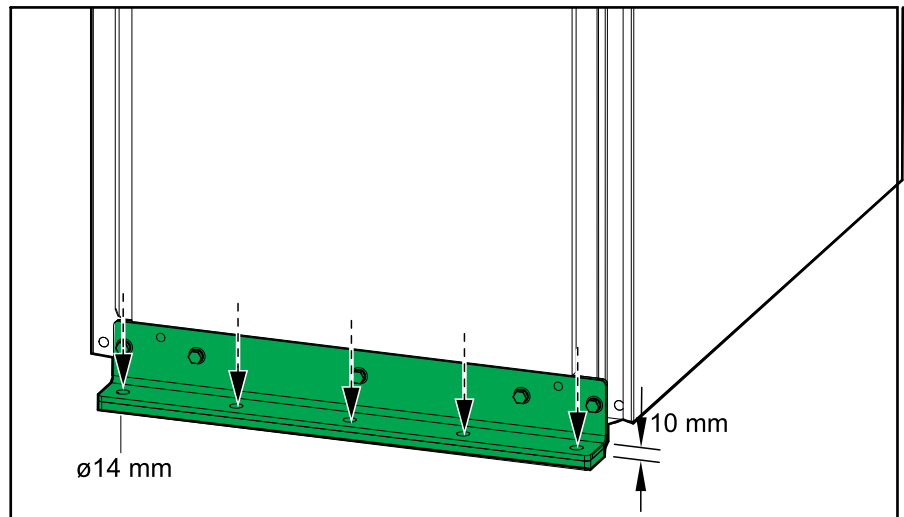

4. Install the front anchoring bracket on the UPS and mount it to the floor. Use appropriate hardware for the floor type – the hole diameter in the rear anchors is  $\varnothing 14$  mm. The requirement is M12 strength grade 8.8 hardware.

**Option:** Use the shimming sheet (870-91123) for alignment with a two meter tall rack.

**Front View (without Shimming Sheet)**

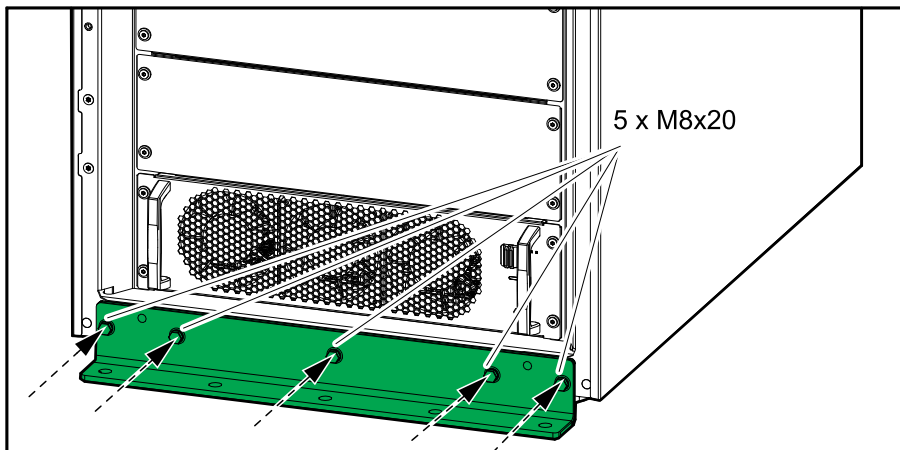

**Front View (with Shimming Sheet)**

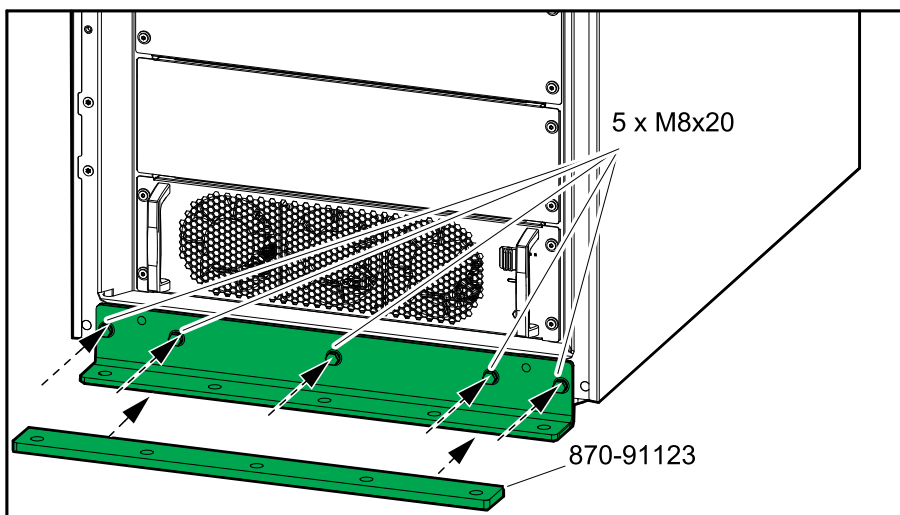

**Front View (without Shimming Sheet)**

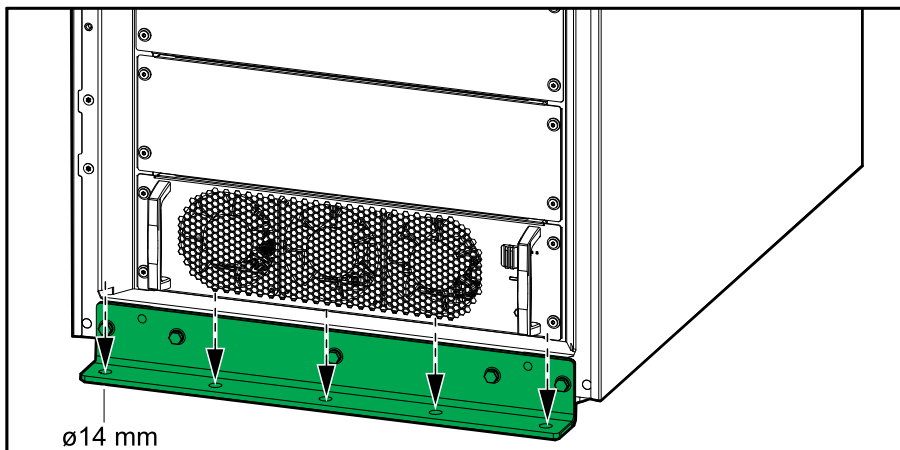

**Front View (with Shimming Sheet)**

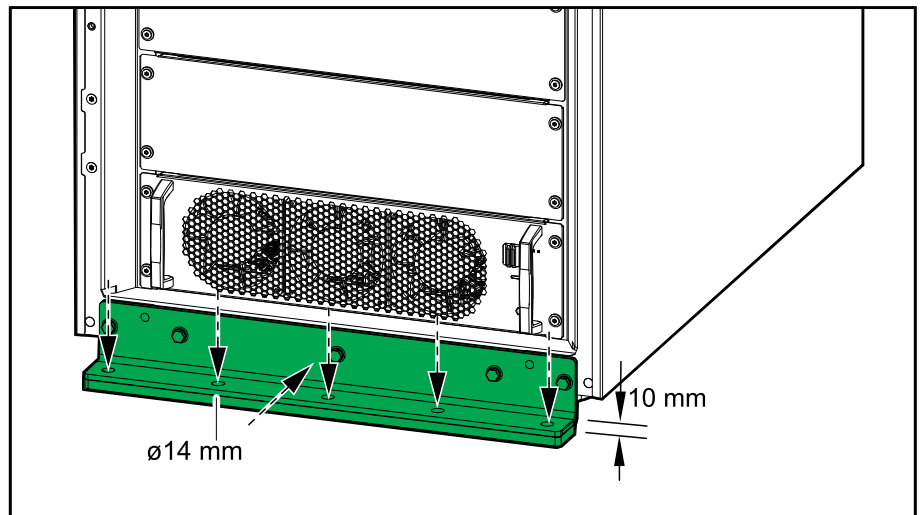

## Prepare the UPS for Top Cable Entry

### **⚡ ⚠ DANGER**

#### **HAZARD OF ELECTRIC SHOCK, EXPLOSION, OR ARC FLASH**

Do not drill or punch holes with the gland plates installed and do not drill or punch holes in close proximity to the cabinet.

**Failure to follow these instructions will result in death or serious injury.**

1. Prepare for power cables:
  - a. Remove the gland plate from the top of the UPS.
  - b. Drill/punch holes for power cables or glands/grommets in the gland plate. Install glands/grommets (not provided), if applicable.
  - c. Reinstall the gland plate.

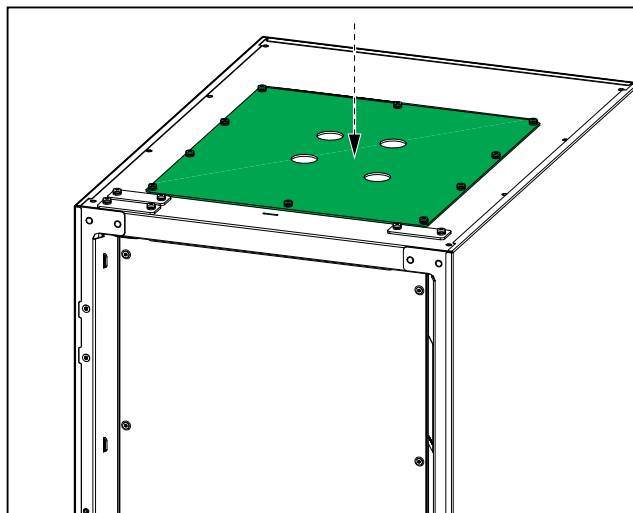
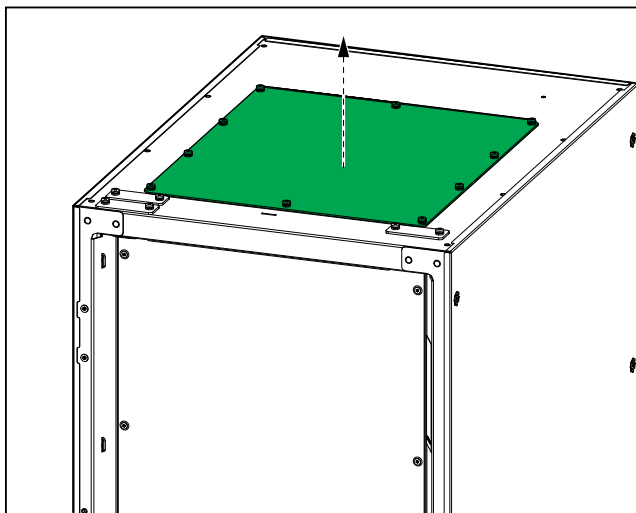

2. Remove the front inner cover(s) from the UPS.

UPS with One Internal Switch

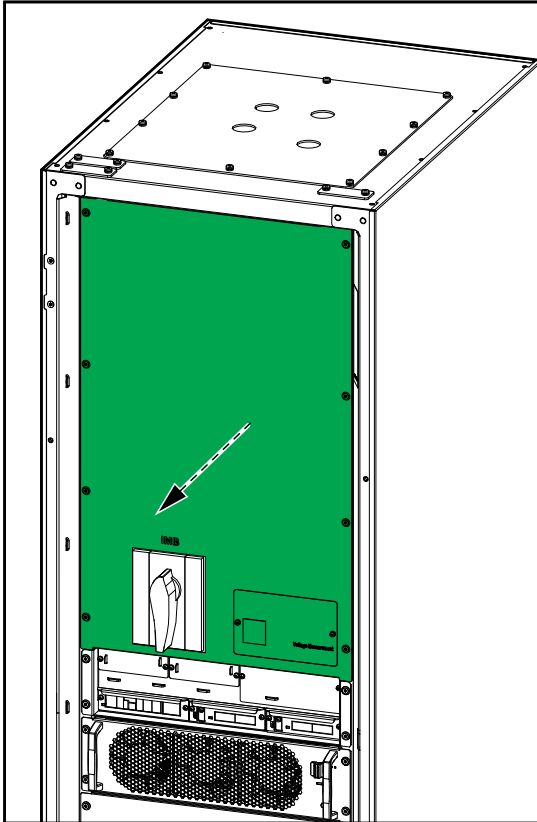

UPS with Four Internal Switches

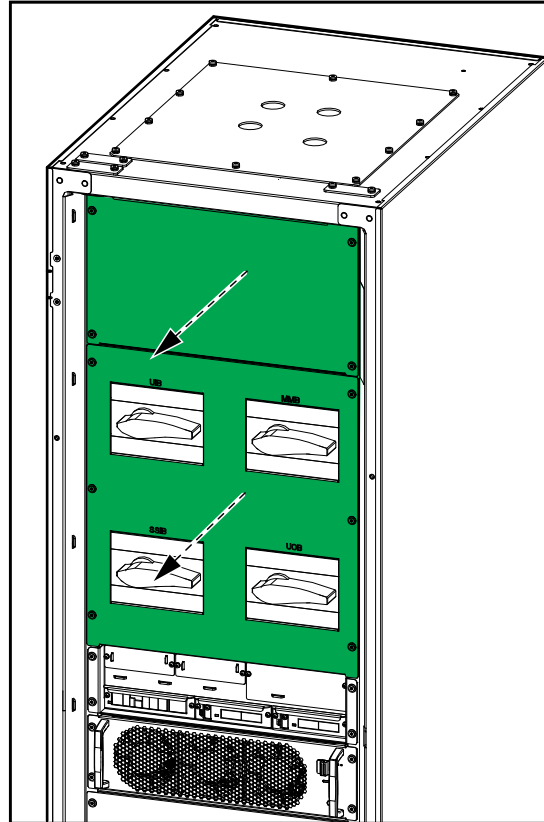

3. Remove the rear panel from the UPS.

Rear View

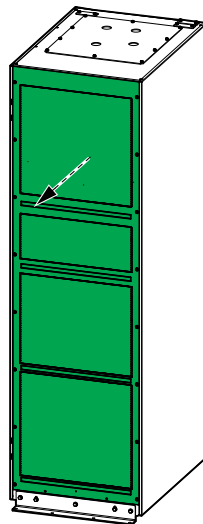

4. Remove the signal cable covers from the top of the UPS.

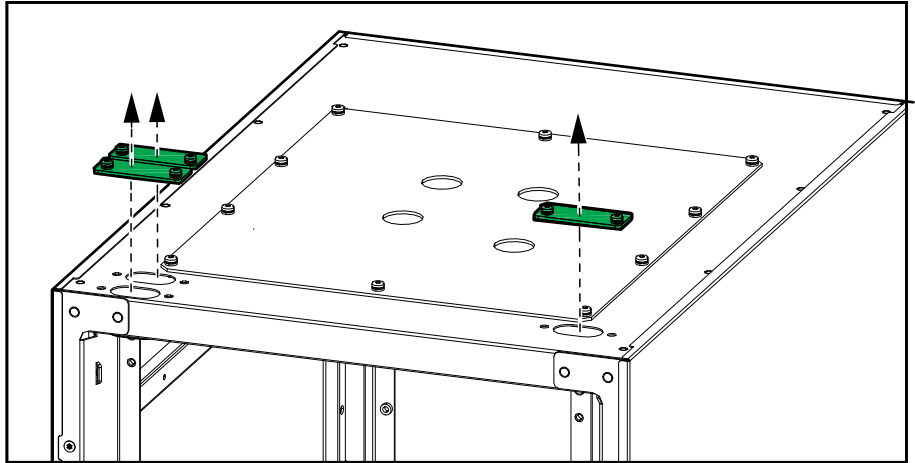

5. Perform one of the following:

- Install the provided cable brush plugs from the hardware kit, OR

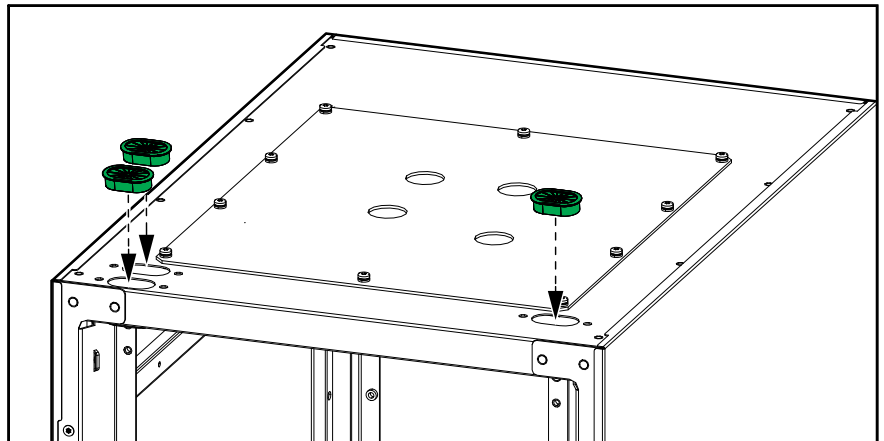

- Drill holes in the signal cable covers. Install glands/grommets (not provided) if applicable. Reinstall the signal cable covers.

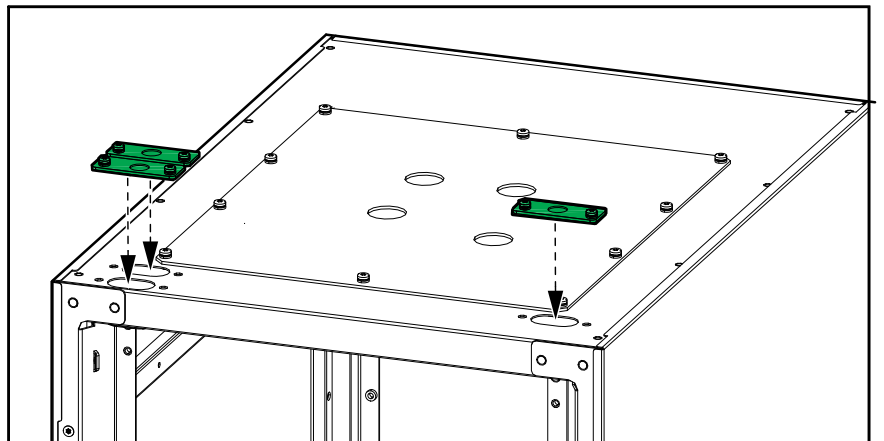

6. Remove the cover from the signal connection terminals.

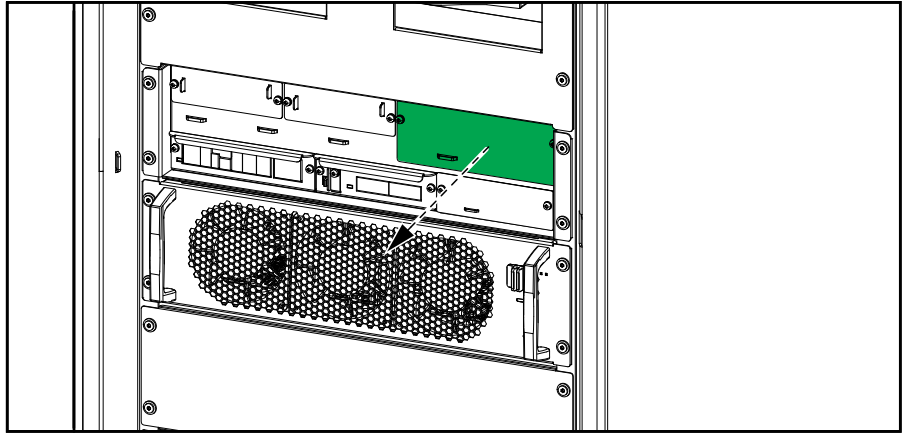

7. Route the signal cables as shown to separate the Class 2/SELV cables from the non-Class 2/non-SELV cables.

**NOTE:** For more information about the locations of Class 2/SELV and non-Class 2/non-SELV cables, see [Connect the Signal Cables](#), page 58.

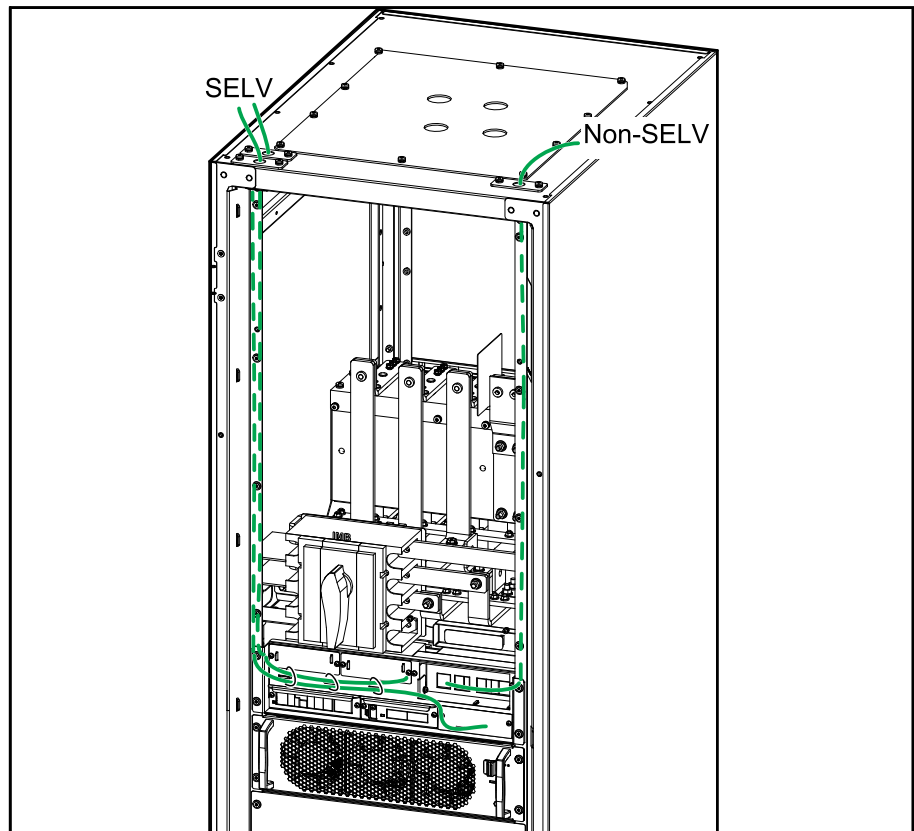

# Prepare for TN-C Earthing System

1. Unpack the optional grounding kit and install the copper busbar (880-74018 or 880-74127) in the UPS.

## UPS with One Internal Switch

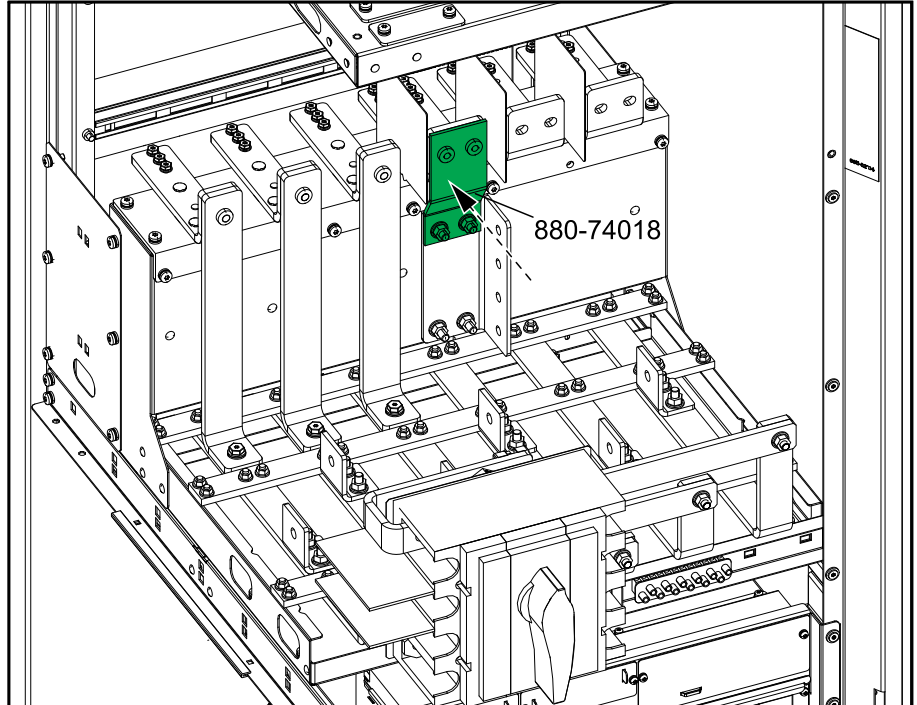

## UPS with Four Internal Switches

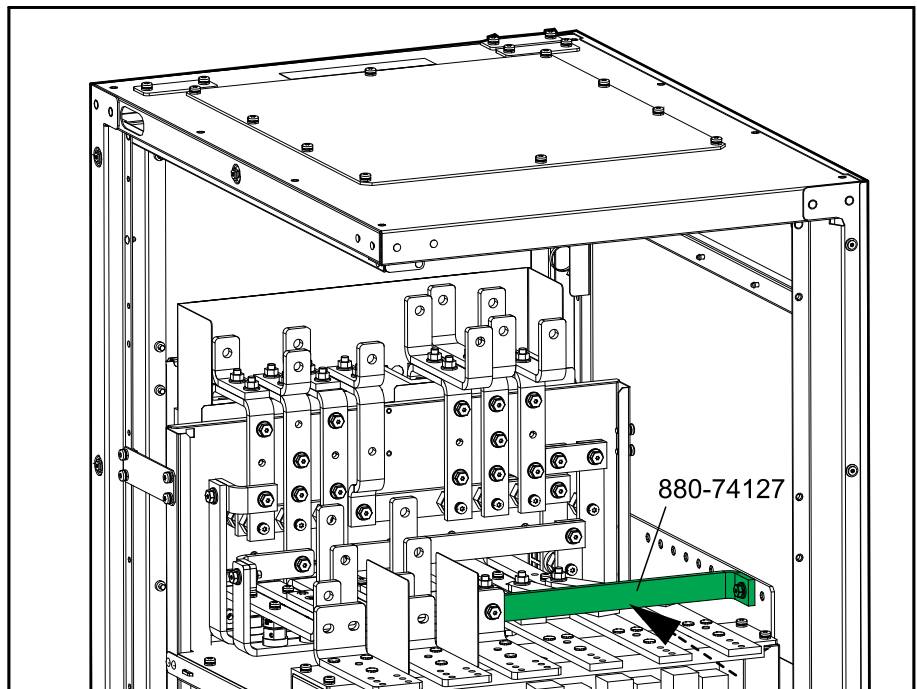

## Install the Neutral Disconnection Kit (Option)

**NOTE:** Use the optional neutral disconnection kit SP3OPT004 for this procedure. The neutral disconnection kit is only applicable for a UPS with one internal switch.

1. Remove the plastic cover from the neutral disconnection assembly.

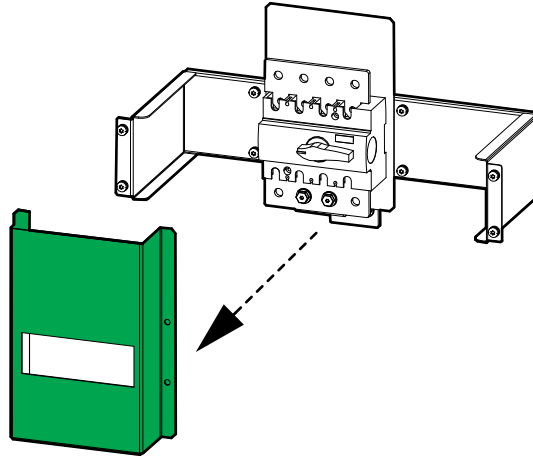

2. Install the neutral disconnection assembly to the rear posts in the UPS with the four provided screws.

### Rear View of the UPS

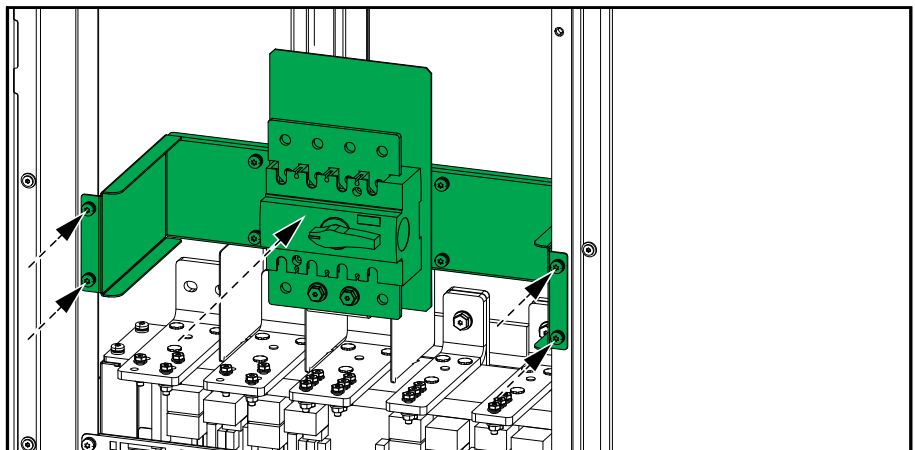

3. Connect the bottom busbar of the neutral disconnection assembly to the neutral busbar in the UPS with the two provided screws.

### Front View of the UPS

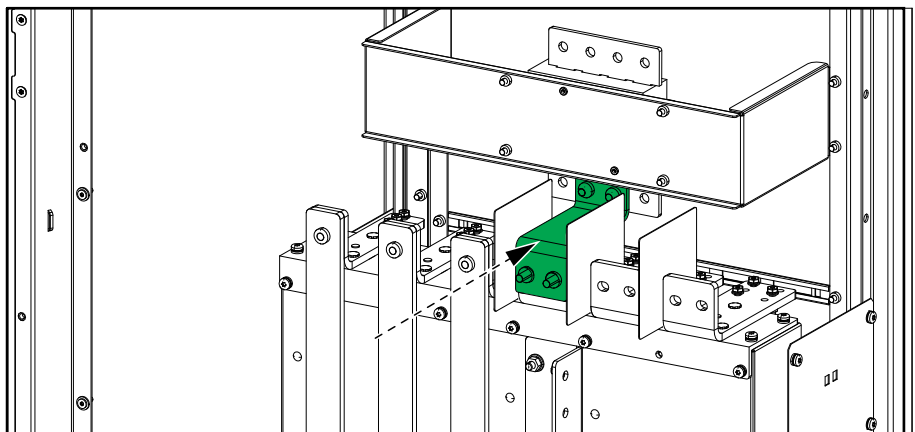

4. Connect the external neutral cables to the upper busbar of the neutral disconnection assembly.

#### Rear View of the UPS

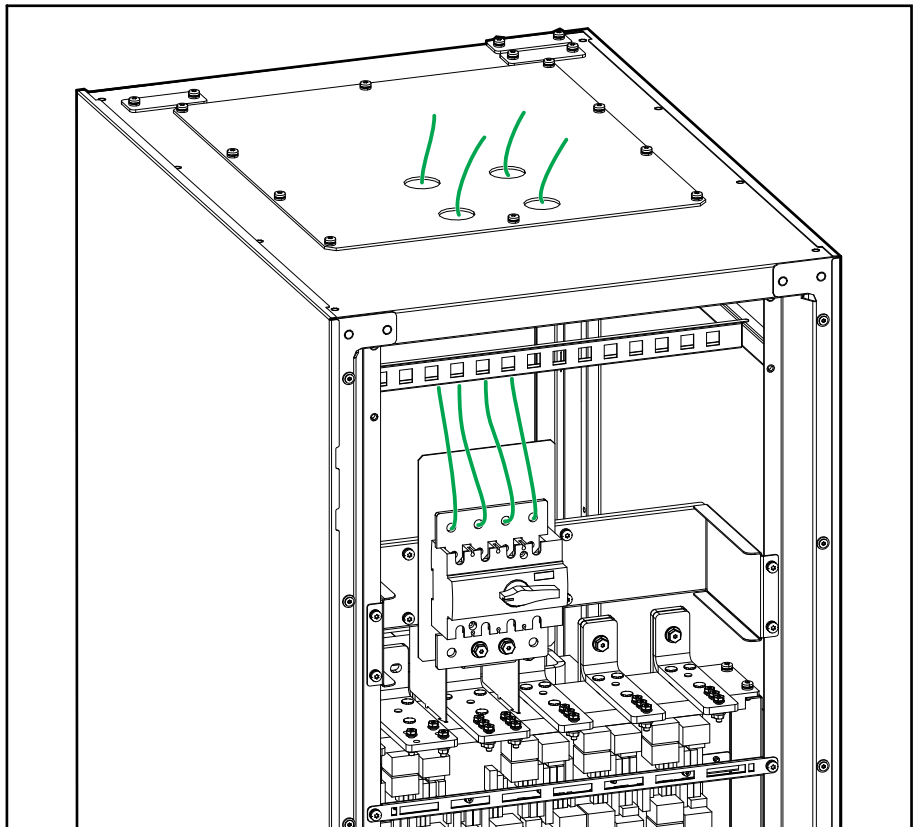

5. Reinstall the plastic cover on the neutral disconnection assembly.

#### Rear View of the UPS

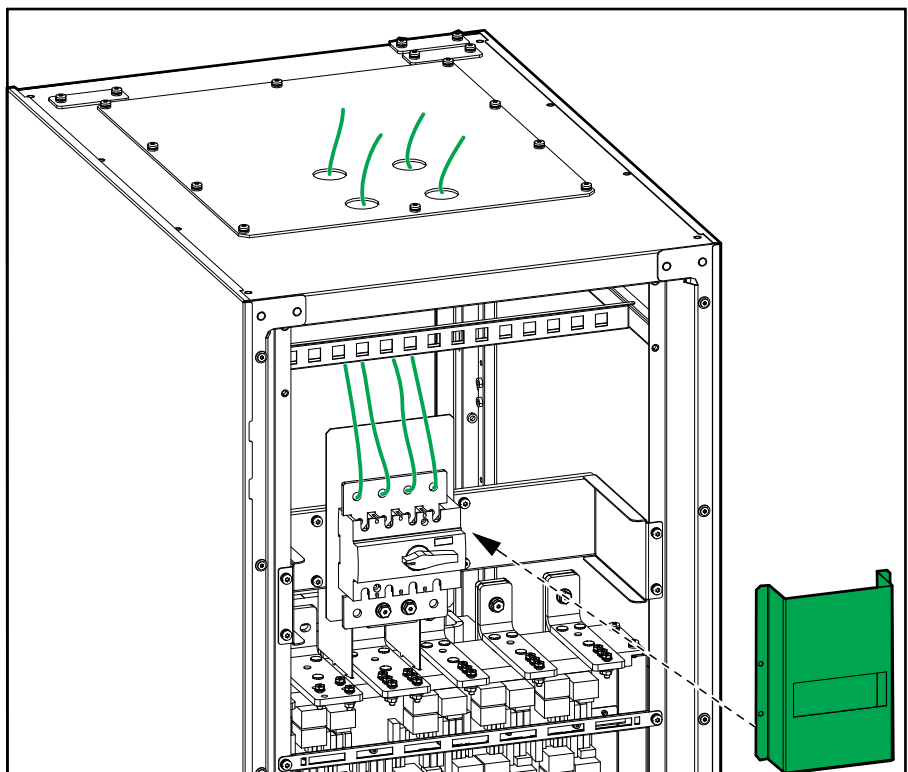

# Connect the Power Cables for the UPS with One Internal Switch

1. **Only for dual mains:** Remove the single mains jumper busbars.

**NOTE:** Save the single mains jumper busbars. They are needed for testing during start-up of the UPS.

## Front View of the UPS

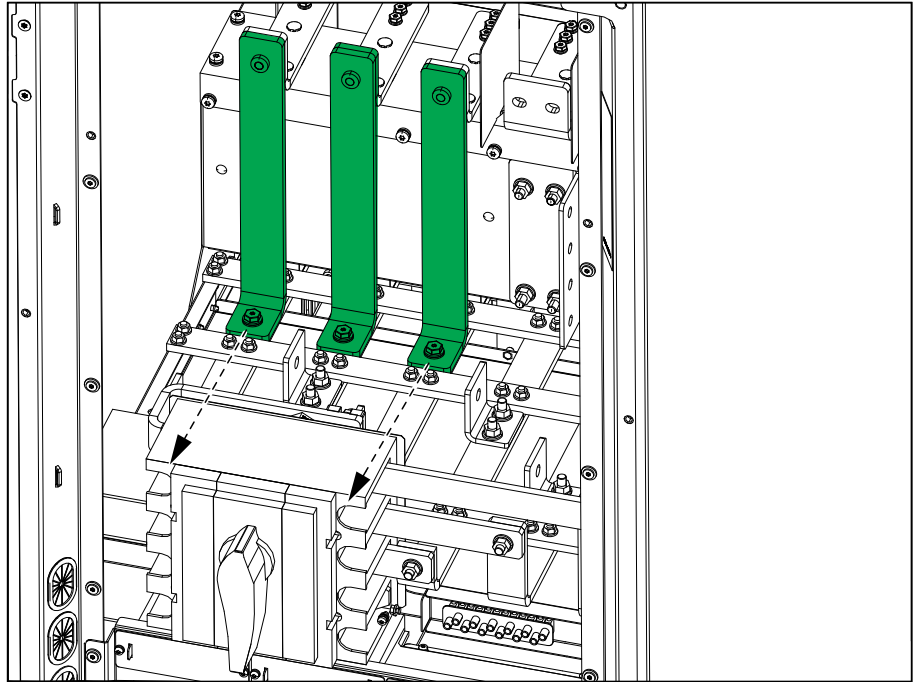

2. Connect the power cables in the described order.
  - a. Connect the PE cables.
  - b. Connect the input cables (L1, L2, L3, (N)).
  - c. **Only for dual mains:** Connect the bypass cables (L1, L2, L3, N).
  - d. Connect the output cables (L1, L2, L3, N).
  - e. Connect the DC cables (DC+, DC-).

### Single Mains

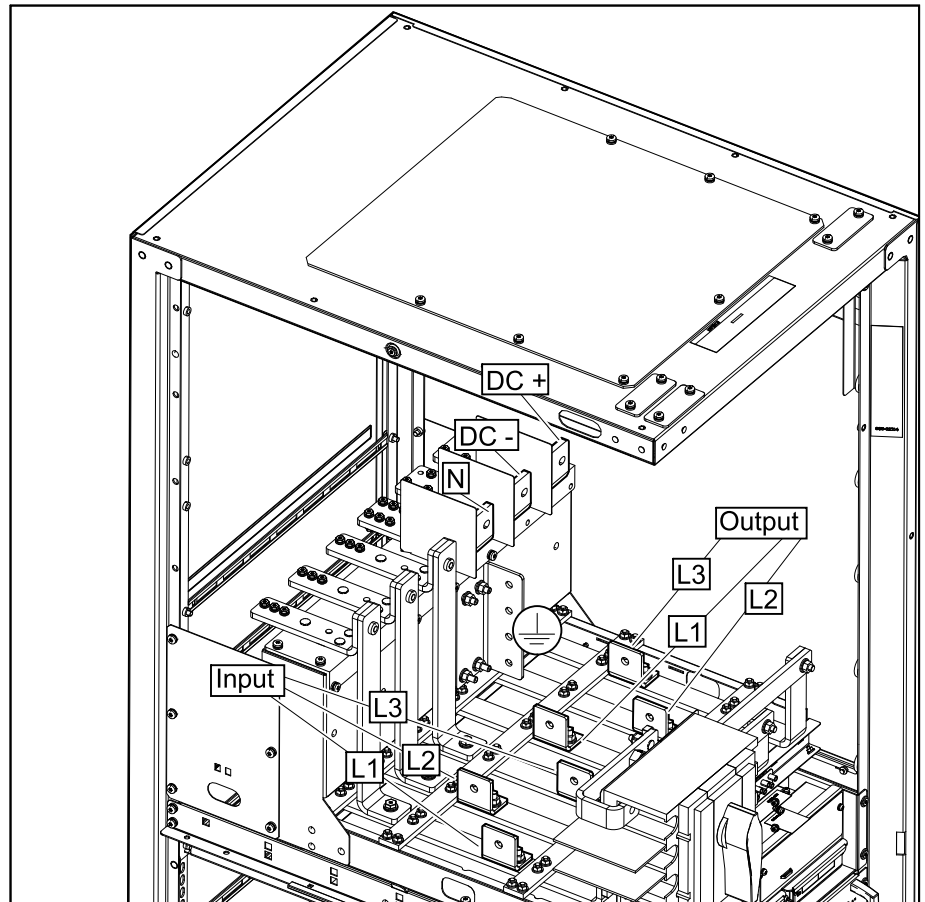

### Dual Mains

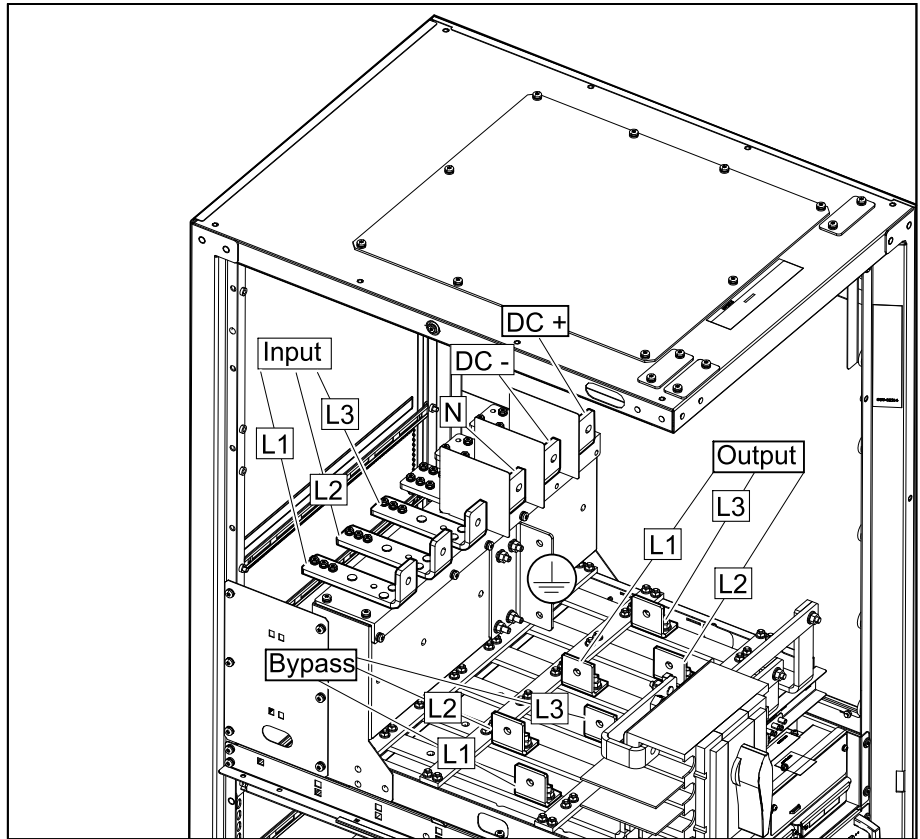

3. Reinstall the rear panel on the UPS.

### Rear View

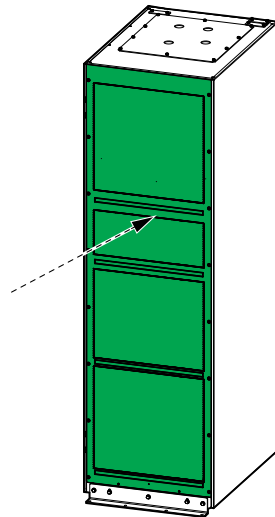

# Connect the Power Cables for the UPS with Four Internal Switches

1. **Only when the local codes/regulations require removal of the neutral jumper:** Remove the neutral jumper (880-74129). The neutral jumper makes a bolted connection of the neutral so that the neutral is not disconnected when the 4-pole switches are opened.

## Rear View of the UPS

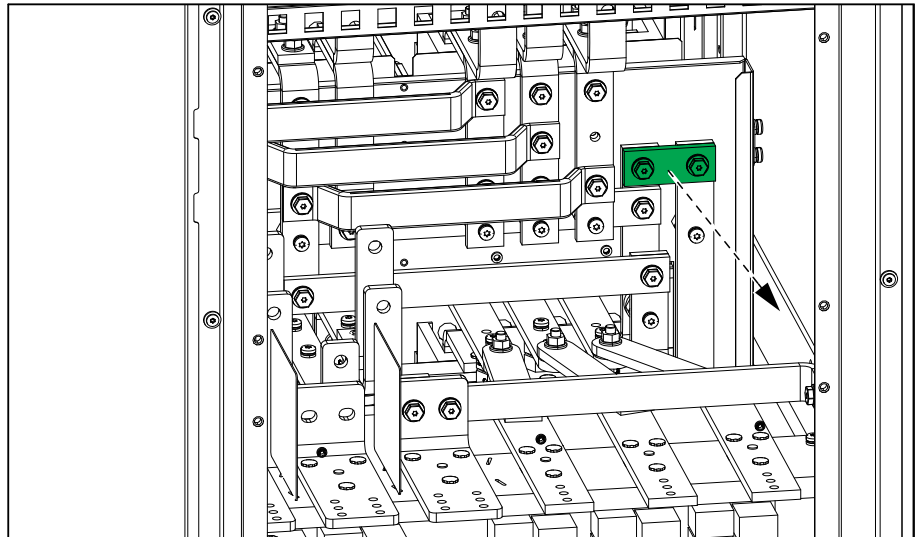

2. **Only for dual mains:** Remove the single mains jumper busbars.  
**NOTE:** Save the single mains jumper busbars. They are needed for testing during start-up of the UPS.

## Rear View of the UPS

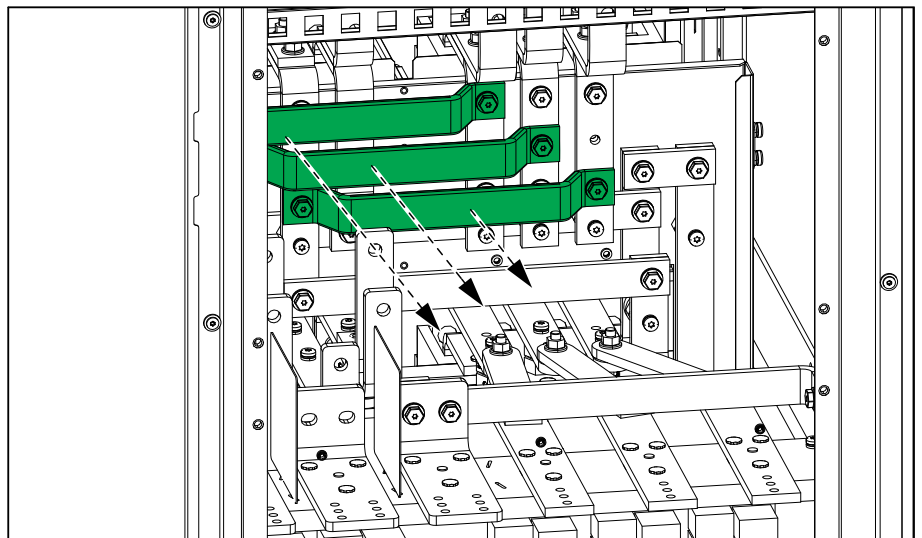

3. Connect the power cables in the described order.
  - a. Connect the PE cables.
  - b. Connect the input cables (L1, L2, L3, (N)).
  - c. **Only for dual mains:** Connect the bypass cables (L1, L2, L3, N).
  - d. Connect the output cables (L1, L2, L3, N).
  - e. Connect the DC cables (DC+, DC-).

### Single Mains

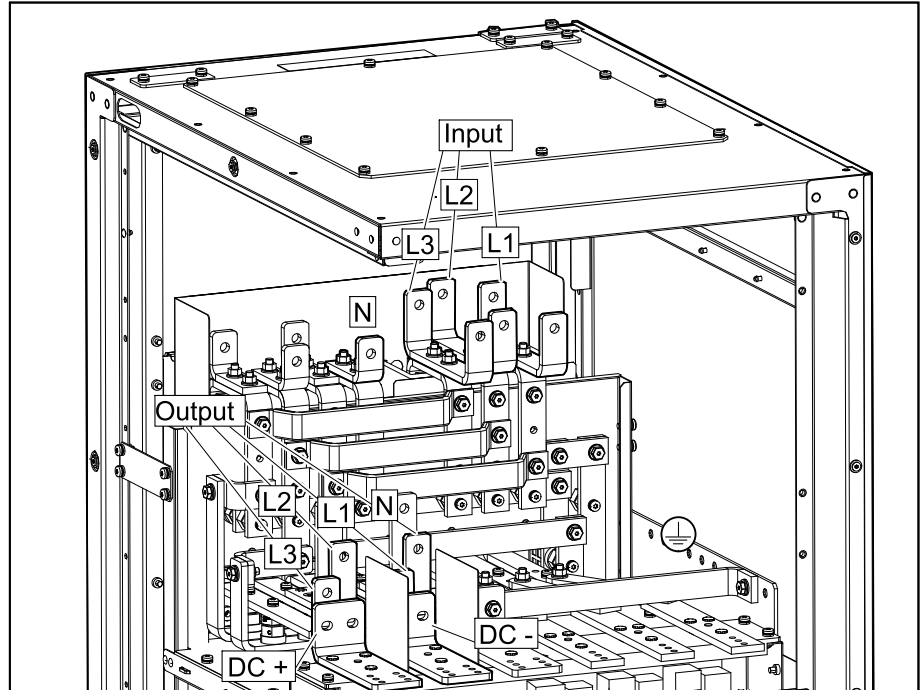

### Dual Mains

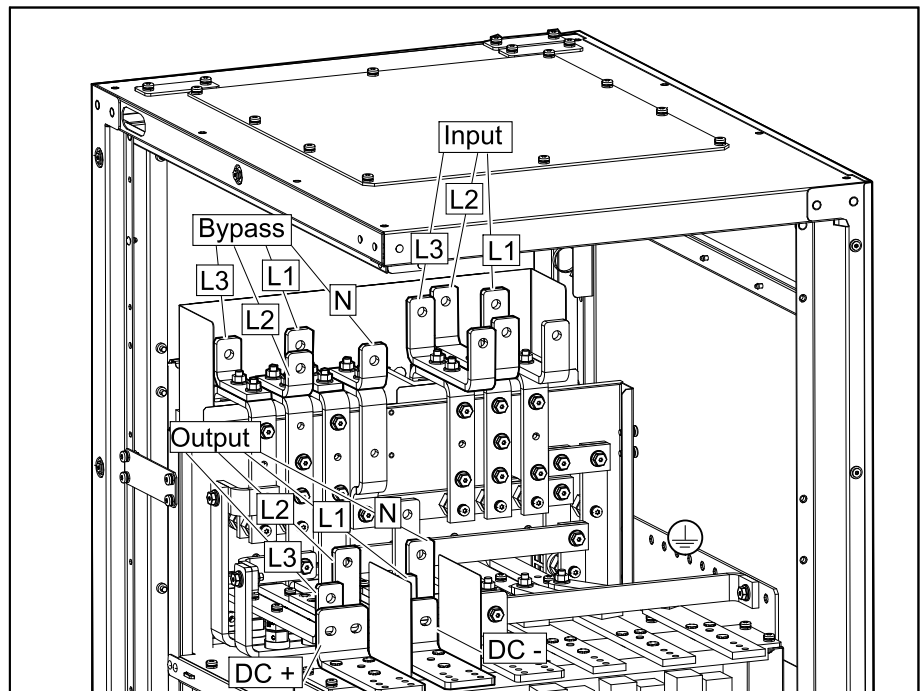

4. Reinstall the rear panel on the UPS.

**Rear View**

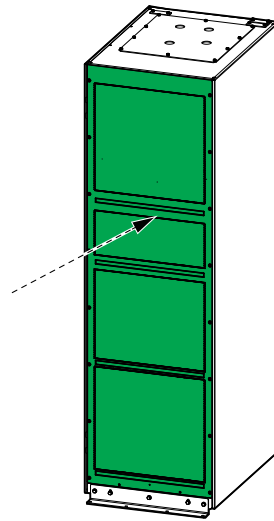

# Connect the Signal Cables

## Overview of Signal Connection Terminals in the UPS

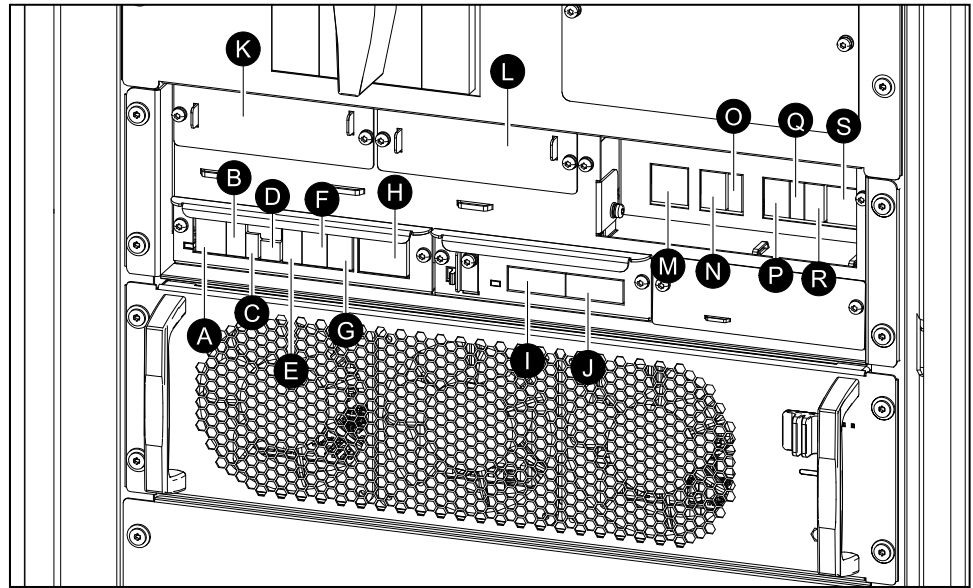

- A. Remote EPO (J6600)
- B. Display port (for internal use)
- C. USB port (for service)
- D. Tuner port (for service)
- E. Modbus port
- F. Battery temperature sensor (J3008)
- G. Input contacts (J3009)
- H. Output relays (J3001)
- I. PBUS2
- J. PBUS1
- K. Network management card (NMC) slot 1
- L. Network management card (NMC) slot 2
- M. Backfeed relay and sync output relay (J8310)
- N. Auxiliary contacts 1 (J8302)
- O. Auxiliary contacts 2 (J8303)
- P. Battery breaker auxiliary contacts (J8304)
- Q. IMB and RIMB auxiliary contacts (J8305)
- R. Sync input (J8300)
- S. Battery breaker trip (J8301)

**NOTE:** Route the signal cables separately from the power cables and route the Class 2/SELV cables (A to L) separately from the non-Class 2/non-SELV cables (M to S). Non-Class 2/non-SELV cables should be rated for 600 V.

**NOTE:** The recommended size for the signal cables is 0.5 mm<sup>2</sup>.

**NOTE:** Do not unplug the signal terminals by hand. Be sure to use the tool (TME12560) in the accessory bag to unplug the signal terminals. Be sure to restore the two rows of terminals to their original position: the grey terminals in the upper row and the green terminals in the lower row.

- Use the provided terminal unplug tool (TME12560) to remove the covers for the signal connection terminals. Save the tool for future use.

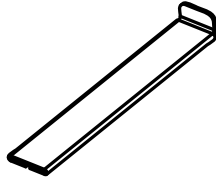

- Connect the Class 2/SELV signal cables from the building EPO to the remote EPO (J6600) in the UPS according to one of the options below.

The EPO circuit is considered Class 2/SELV. Class 2/SELV circuits must be isolated from the primary circuitry. Do not connect any circuit to the EPO terminal block unless it can be confirmed that the circuit is Class 2/SELV.

**EPO Configurations (Terminal J6600, 1-9)**

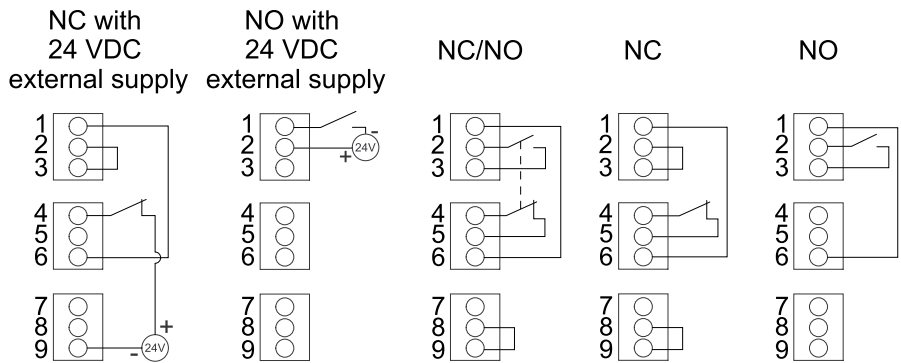

The EPO input supports 24 VDC.

**NOTE:** The default setting for the EPO activation is to turn off the inverter.

If you want the EPO activation to transfer the UPS into forced static bypass operation instead, please contact Schneider Electric.

- Connect the Class 2/SELV signal cables to the input contacts and output relays in the UPS.

Do not connect any circuit to the input contacts unless it can be confirmed that the circuit is Class 2/SELV.

The input contacts support 24 VDC 10 mA. All circuits connected must have the same 0 V reference.

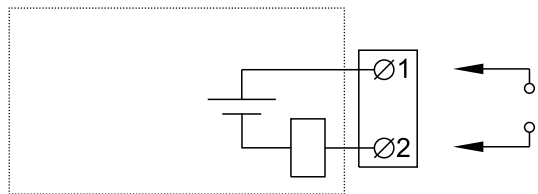

Name	Description	Location
IN_1 (input contact 1)	Configurable input contact	Terminal J3009, 1-2
IN_2 (input contact 2)		Terminal J3009, 3-4
IN_3 (input contact 3)		Terminal J3009, 5-6

Name	Description	Location
IN_4 (input contact 4)		Terminal J3009, 7-8

The output relays support 24 VAC/VDC 1 A. All external circuitry must be fused with maximum 1 A fast acting fuses.

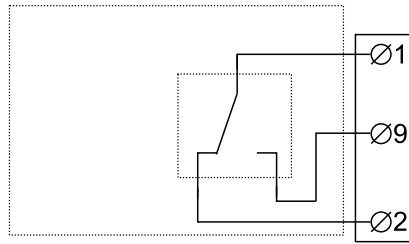

Name	Description	Location
OUT_1 (output relay 1)	Configurable output relay	Terminal J3001, 1, 9, 2
OUT_2 (output relay 2)		Terminal J3001, 10, 3, 11
OUT_3 (output relay 3)		Terminal J3001, 4, 12, 5
OUT_4 (output relay 4)		Terminal J3001, 13, 6, 14
OUT_5 (output relay 5)		Terminal J3001, 7, 15, 8

4. Connect the signal cables from the auxiliary products to the UPS. Follow the instructions in the auxiliary product manuals.

# Connect the Signal Cables from Switchgear and Third-Party Auxiliary Products

**NOTE:** Route the signal cables separately from the power cables and route the Class 2/SELV cables separately from the non-Class 2/non-SELV cables.

1. Install the optional battery temperature sensor in the battery solution. In battery cabinets, install the battery temperature sensor in the top corner of the battery cabinet.

<b>▲ WARNING</b>
<b>HAZARD OF FIRE</b>
Position the battery temperature sensor as described to ensure correct temperature measurements.
<b>Failure to follow these instructions can result in death, serious injury, or equipment damage.</b>

2. Route the battery temperature sensor cables from the battery solution to the UPS and connect as shown.

**NOTE:** Battery temperature sensors (SP3OPT006) are available as an optional kit.

**NOTE:** The battery temperature sensor cables are considered Class 2/SELV. Class 2/SELV circuits must be isolated from the primary circuitry.

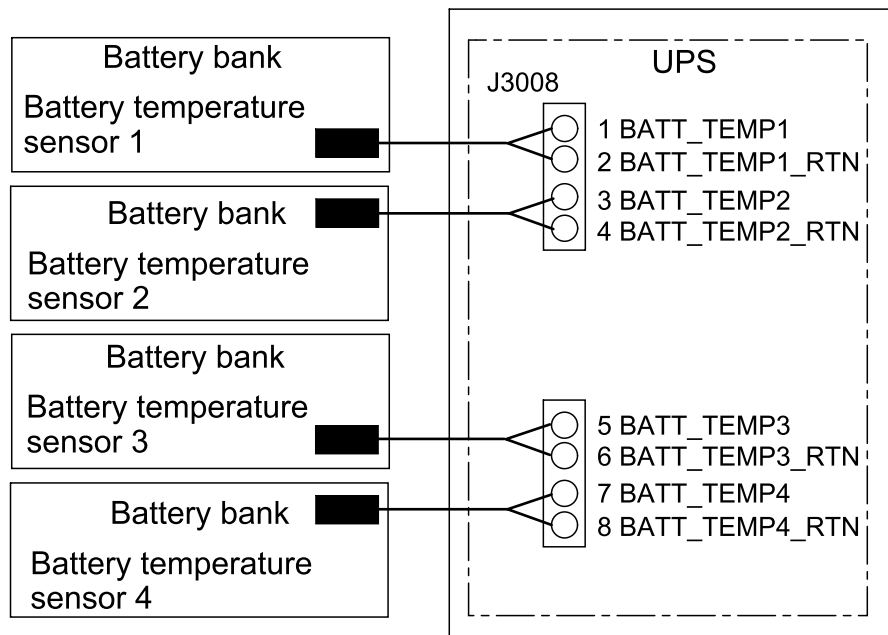

3. Connect the signal cables from the battery breaker(s) in your battery solution for shunt trip or undervoltage (UV) trip connection to the UPS. Follow the illustration for connection with internal 24 VDC supply. The UPS can connect to and monitor up to three (if J8301-10 is used for backfeed) or four battery breakers.
  - a. Connect battery breaker 1 to terminal J8301 in the UPS.
  - b. Connect battery breaker 2 to terminal J8301 in the UPS.
  - c. Connect battery breaker 3 to terminal J8301 in the UPS.
  - d. Connect battery breaker 4 to terminal J8301 in the UPS.
  - e. For battery breaker trip 4, connect trip unit negative to pin 1/4/7 of terminal J8301.

**NOTE:** The following diagram and table demonstrate the battery breaker trip connection with internal 24 VDC supply and pin connections.

**Battery Breaker Trip Connection with Internal 24 VDC Supply**

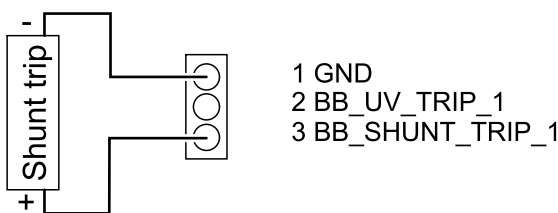
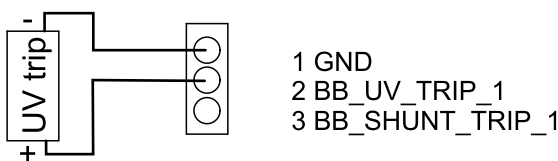

**J8301 Pin Connections for Battery Breaker(s)**

**Battery Breaker 1**

Pin number	Function
1	GND
2	GNDBB_UV_TRIP_1
3	BB_SHUNT_TRIP_1

**Battery Breaker 2**

Pin number	Function
4	GND
5	BB_UV_TRIP_2
6	BB_SHUNT_TRIP_2

**Battery Breaker 3**

Pin number	Function
7	GND
8	BB_UV_TRIP_3
9	BB_SHUNT_TRIP_3

**Battery Breaker 4**

Pin number	Function
10	24 V
11	BB_UV_TRIP_4
12	BB_SHUNT_TRIP_4

4. Connect signal cables from the auxiliary contacts in your switchgear to the UPS.

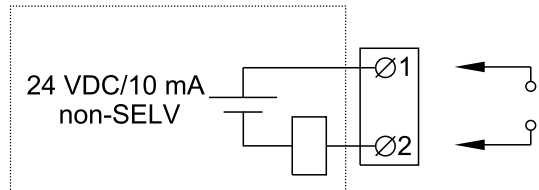

Terminal number	Function	Connection
J8302, 1-2	UIB (unit input breaker)	Connect to normally open (NO) auxiliary contacts in unit input breaker UIB. UIB must contain an auxiliary contact for each connected UPS.
J8302, 3-4	SSIB (static switch input breaker)	Connect to normally open (NO) auxiliary contacts in static switch input breaker SSIB. SSIB must contain an auxiliary contact for each connected UPS.
J8302, 5-6	Ext. MBB (external maintenance bypass breaker)	Connect to normally closed (NC) auxiliary contacts in external maintenance bypass breaker (Ext. MBB). Ext. MBB must contain an auxiliary contact for each connected UPS.
J8302, 7-8	UOB (unit output breaker)	Connect to normally open (NO) auxiliary contacts in unit output breaker UOB.
J8303, 1-2	UOB (redundant AUX switch in unit output breaker)	Connect to redundant auxiliary contacts in unit output breaker UOB.
J8303, 3-4	SIB (system isolation breaker)	Connect to normally open (NO) auxiliary contacts in system isolation breaker SIB for parallel system. SIB must contain an auxiliary contact for each connected UPS.
J8304, 1-2	BB1 (battery breaker 1)	Connect to normally open (NO) auxiliary contacts in battery breaker number 1.
J8304, 3-4	BB2 (battery breaker 2)	Connect to normally open (NO) auxiliary contacts in battery breaker number 2.
J8304, 5-6	BB3 (battery breaker 3)	Connect to normally open (NO) auxiliary contacts in battery breaker number 3.
J8304, 7-8	BB4 (battery breaker 4)	Connect to normally open (NO) auxiliary contacts in battery breaker number 4.
J8505, 1-2	<b>One internal switch UPS:</b> IMB (internal maintenance breaker) <b>Four internal switches UPS:</b> MBB (maintenance bypass breaker)	Connect to normally closed (NC) auxiliary contacts in internal maintenance breaker IMB or maintenance bypass breaker MBB.
J8505, 3-4	<b>One internal switch UPS:</b> RIMB (remote internal maintenance breaker) <b>Four internal switches UPS:</b> RMBB (remote maintenance bypass breaker)	Connect to normally closed (NC) auxiliary contacts in another UPS's IMB or MBB in the 1+1 parallel system.
J8310, 1	Backfeed relay common	See Backfeed Protection, page 70.
J8310, 2	Backfeed relay normally closed (NC)	See Backfeed Protection, page 70.
J8310, 3	Backfeed relay normally open (NO)	See Backfeed Protection, page 70.

# Connect the Modbus Cables

**NOTE:** For cyber security protection, strict access control to the installation room must be exerted at all times.

1. Connect the Modbus cables to the terminal J3000 of the UPS(s). Use either 2-wire or 4-wire connection.
  - Shielded twisted pair cables must be used for Modbus connections. The shield connection to the ground must be as short as possible (ideally below 1 cm). The cable shield must be connected to the Ch GND pin on each device.
  - Wiring should be done in accordance with local wiring codes.
  - Route signal cables separately from power cables to ensure sufficient isolation.
  - The Modbus port is galvanically isolated with the Ch GND pin as ground reference.

## Example: 2-Wire Connection with Two UPSs

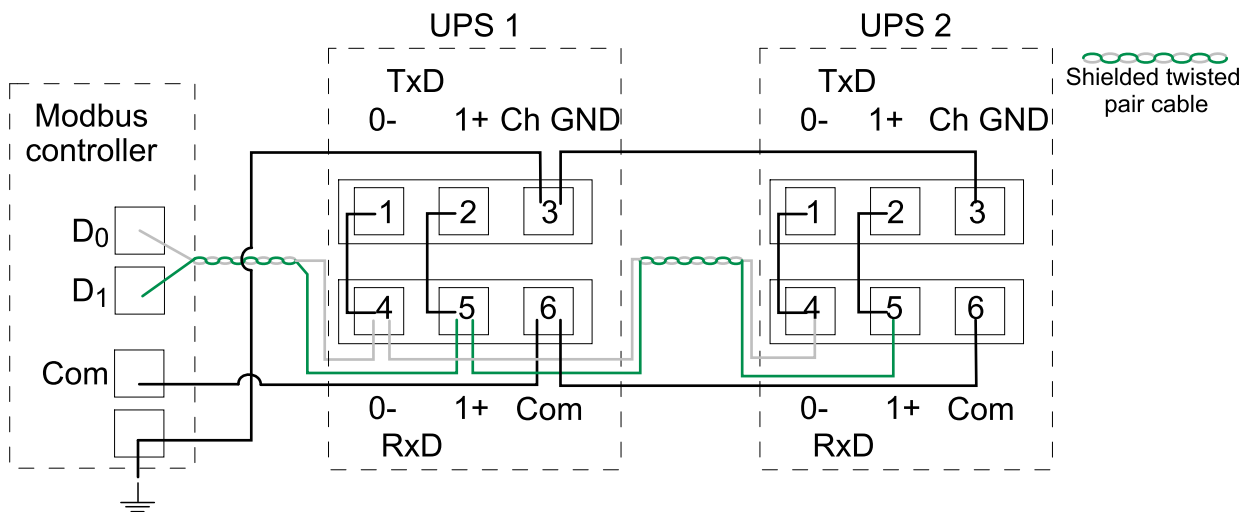

## Example: 4-Wire Connection with Two UPSs

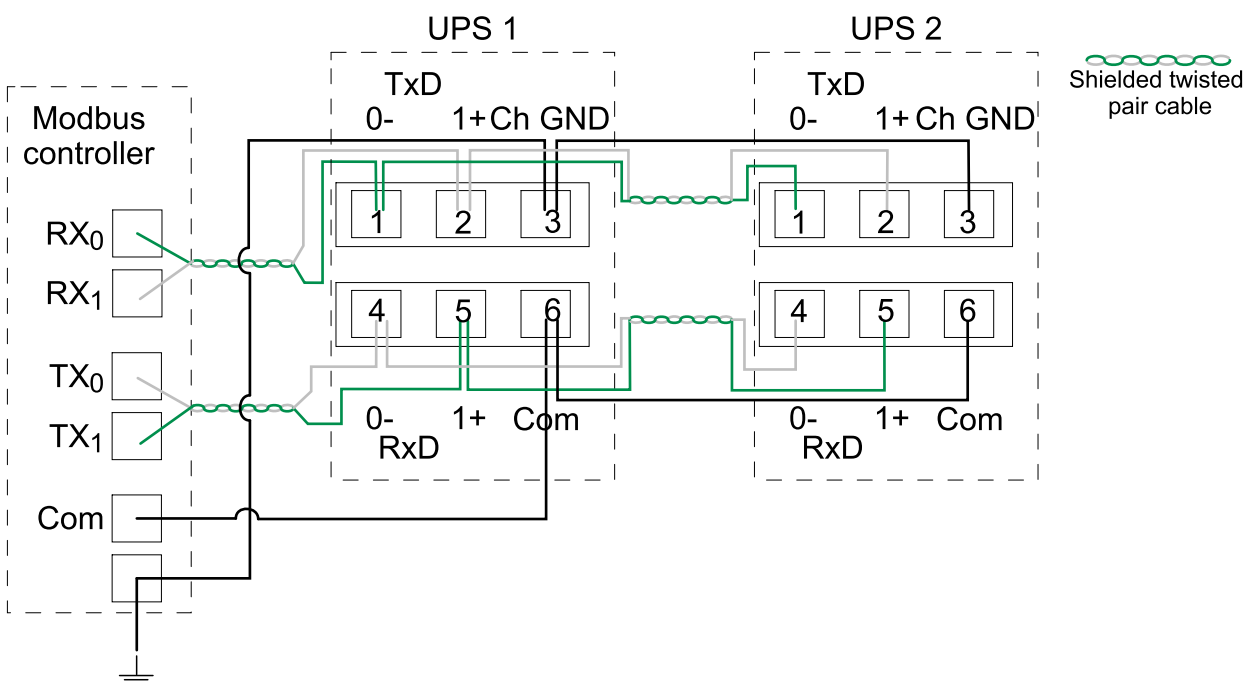

2. Install 150 Ohm termination resistors at each end of each bus if the buses are very long and operate at high data rates. Busses under 610 meters at 9600 baud or under 305 meters at 19.200 baud should not require termination resistors.

# Connect the PBUS Cables

**NOTE:** Do not connect the PBUS cables to the network. The connection is not intended for network connection and may cause inoperability of the network.

1. Connect the provided PBUS 1 (white) and PBUS 2 (red) cables to the PBUS ports on the UPSs.

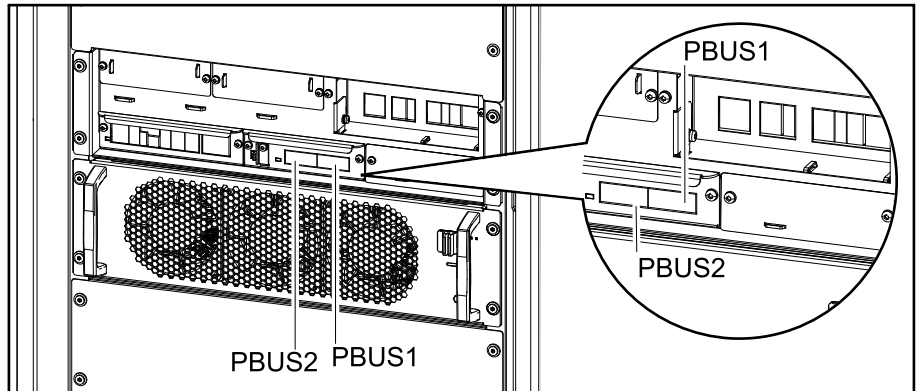

2. Mount termination plugs (T) in the unused connectors.

### Example of System with Three UPSs in Parallel

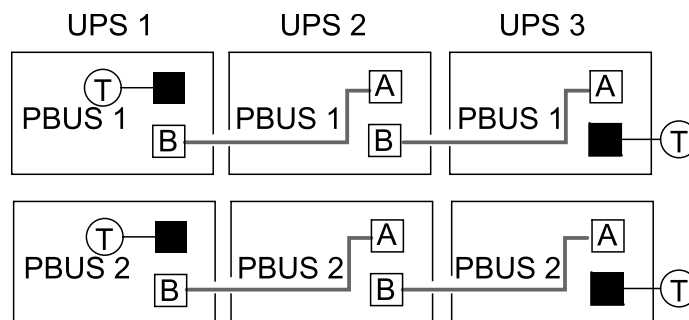

## Install the Power Module(s)

**NOTE:** One 50 kW power module is preinstalled in the UPS. Additional power modules are shipped separately for UPS ratings over 50 kW and must be installed to reach the correct UPS kW rating.

**NOTE:** Install power modules starting with the bottom positions and upward.

### ⚠ WARNING

#### RISK OF EQUIPMENT DAMAGE

- Store the power modules at an ambient temperature of -25 °C to 55 °C, 0-95% non-condensing humidity.
- Store the power modules in their original protective packaging.

**Failure to follow these instructions can result in death, serious injury, or equipment damage.**

### ⚠ CAUTION

#### HEAVY LOAD

Power modules are heavy (28 kg) and require two persons to lift.

**Failure to follow these instructions can result in injury or equipment damage.**

1. Remove the filler plate from the empty power module slot. Save the filler plate for future use.

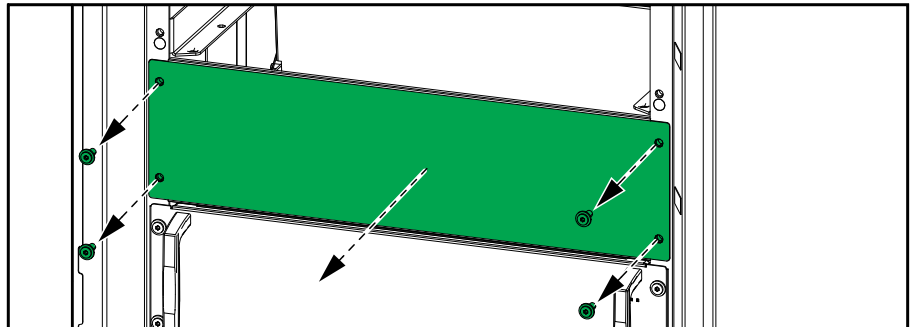

2. Set the unlock tab on the power module to the OFF position. Push the power module into the slot. The enable mechanism will latch when the power module is correctly inserted.

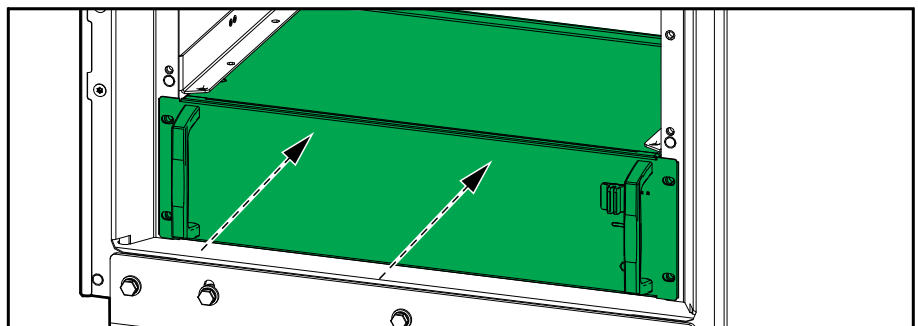

3. Reinstall the screws in the sides of the power module.

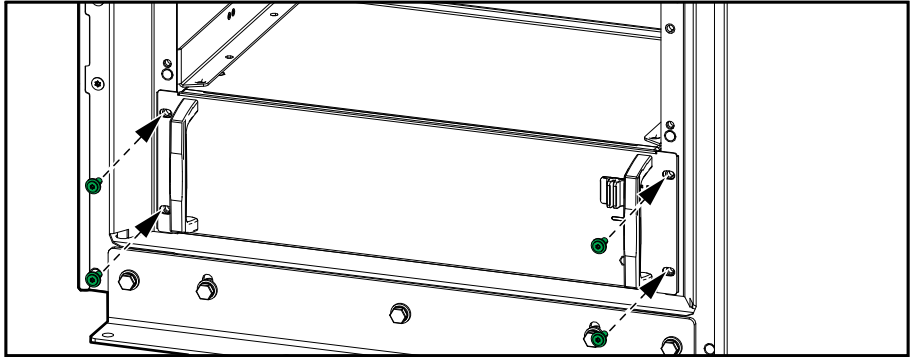

4. Set the unlock tab on the power module to the ON position.

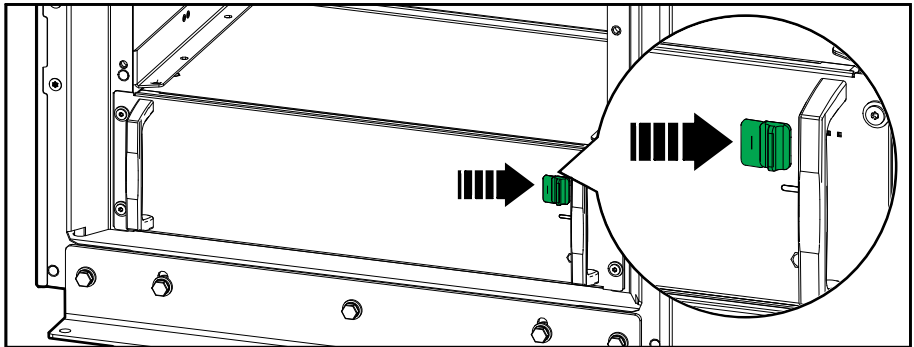

## **⚡ ⚠ DANGER**

### **HAZARD OF ELECTRIC SHOCK, EXPLOSION, OR ARC FLASH**

All power module slots must have either a power module or a filler plate installed.

**Failure to follow these instructions will result in death or serious injury.**

## Backfeed Protection

### **DANGER**

#### **HAZARD OF ELECTRIC SHOCK, EXPLOSION, OR ARC FLASH**

Mandatory backfeed protection on bypass must be implemented by installation of upstream breaker with shunt trip or under voltage trip connected to the UPS. See diagrams and instructions below.

**Failure to follow these instructions will result in death or serious injury.**

## Installation of Third Party Backfeed Protection

Connect the breaker shunt trip/ under voltage trip and auxiliary contacts to the UPS as shown below. Use double insulated cables. Breaker shunt trip or under voltage trip must be rated for 24 VDC nominal, inrush max 20 W.

885-92858 (provided with the UPS) must be placed visible at the bypass upstream breaker.

### **DANGER**

#### **HAZARD OF ELECTRIC SHOCK, EXPLOSION, OR ARC FLASH**

In systems where backfeed protection is not a part of the standard design, an automatic isolation device (Schneider Electric backfeed protection option or other device, such as a breaker, switch, or contactor with trip function, meeting the requirements of IEC62040-1 or UL1778 5th edition – depending on which standard applies to your local area), is required to be installed to prevent hazardous voltage or energy at the input terminals of the isolation device. The device must be rated and controlled according to the specifications in this manual.

**Failure to follow these instructions will result in death or serious injury.**

When the UPS input is connected through external isolators that, when opened, isolate the neutral or when the automatic backfeed isolation is provided external to the equipment or is connected to an IT power distribution system, a label must be fitted at the UPS input terminals, and on all primary power isolators installed remotely from the UPS area and on external access points between such isolators and the UPS, by the user, displaying the following text (or equivalent in a language which is acceptable in the country in which the UPS system is installed):

### **DANGER**

#### **HAZARD OF ELECTRIC SHOCK, EXPLOSION, OR ARC FLASH**

Risk of voltage backfeed. Before working on this circuit: Isolate the UPS and check for hazardous voltage between all terminals including the protective earth.

**Failure to follow these instructions will result in death or serious injury.**

**UPS and Third Party Backfeed Protection (UVR trip) – Single Mains**

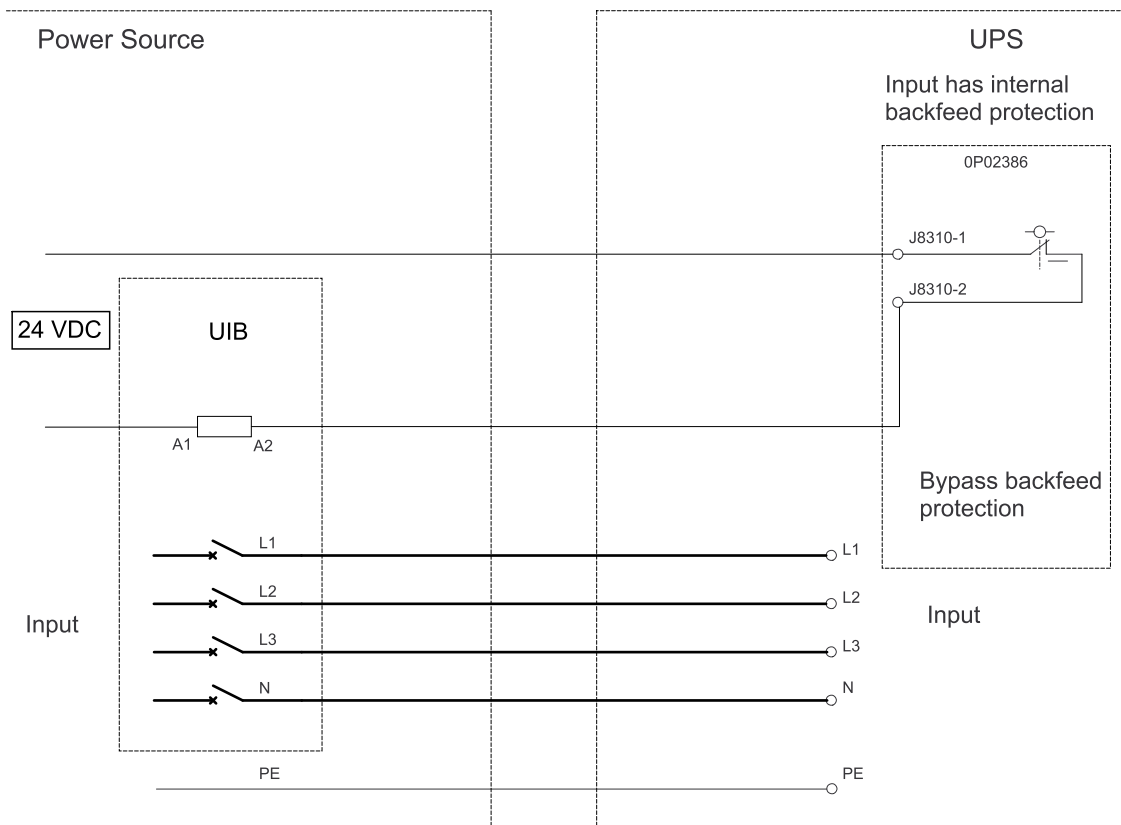

**NOTE:** An external 24 V power supply is required for backfeed protection with UVR trip.

**UPS and Third Party Backfeed Protection (Shunt trip) – Single Mains**

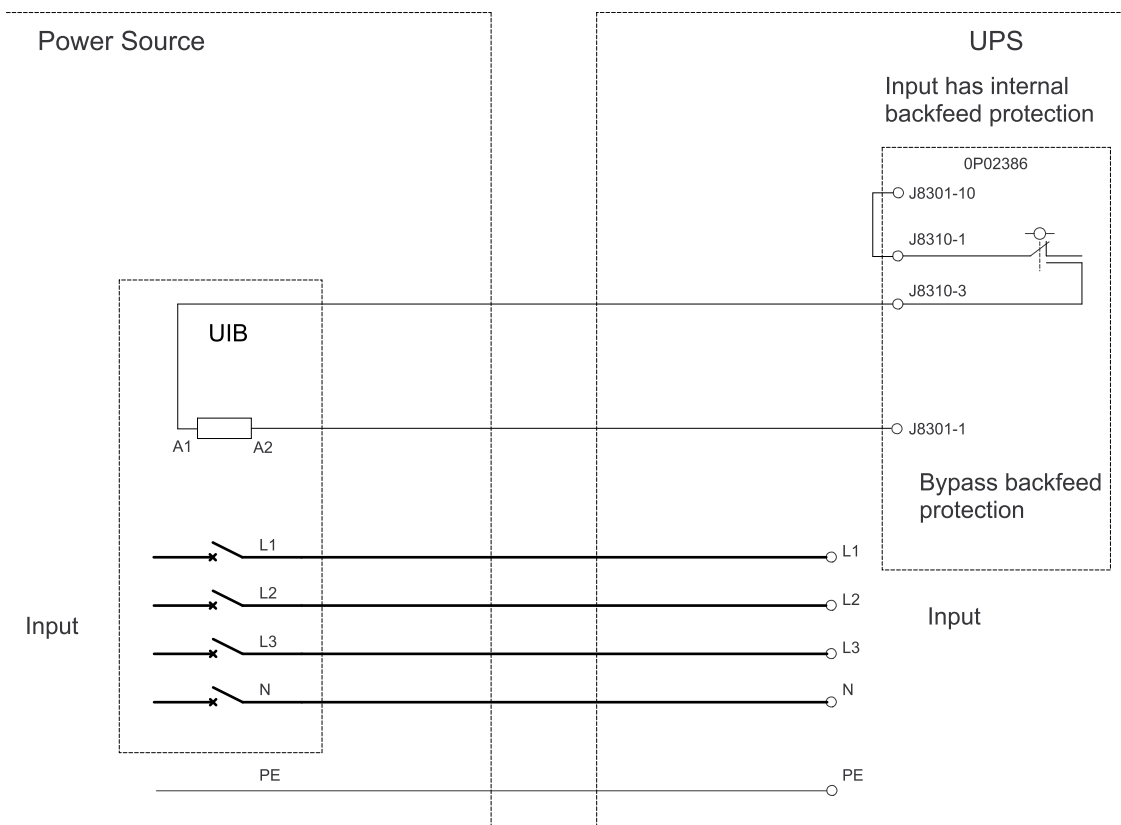

**UPS and Third Party Backfeed Protection (UVR trip) – Dual Mains**

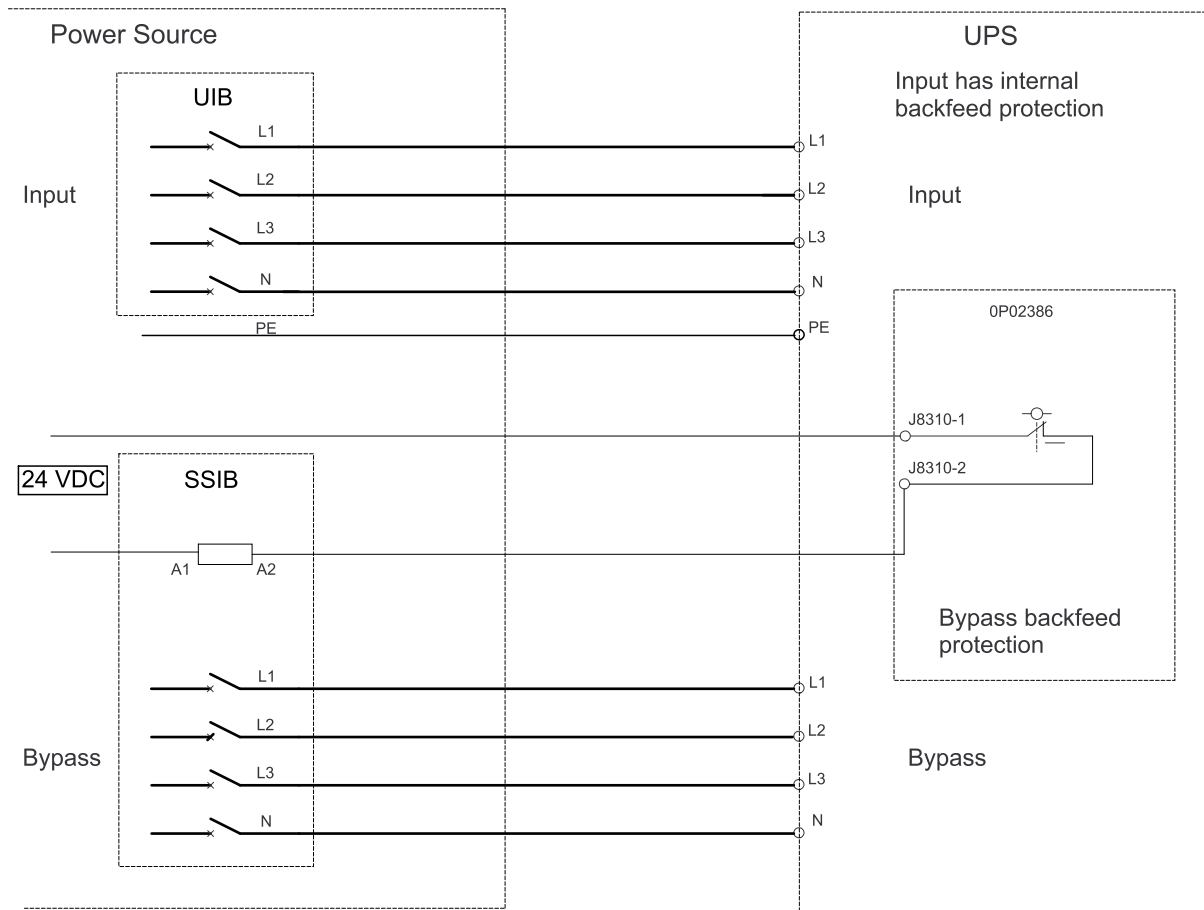

**NOTE:** An external 24 V power supply is required for backfeed protection with UVR trip.

### UPS and Third Party Backfeed Protection (Shunt trip) – Dual Mains

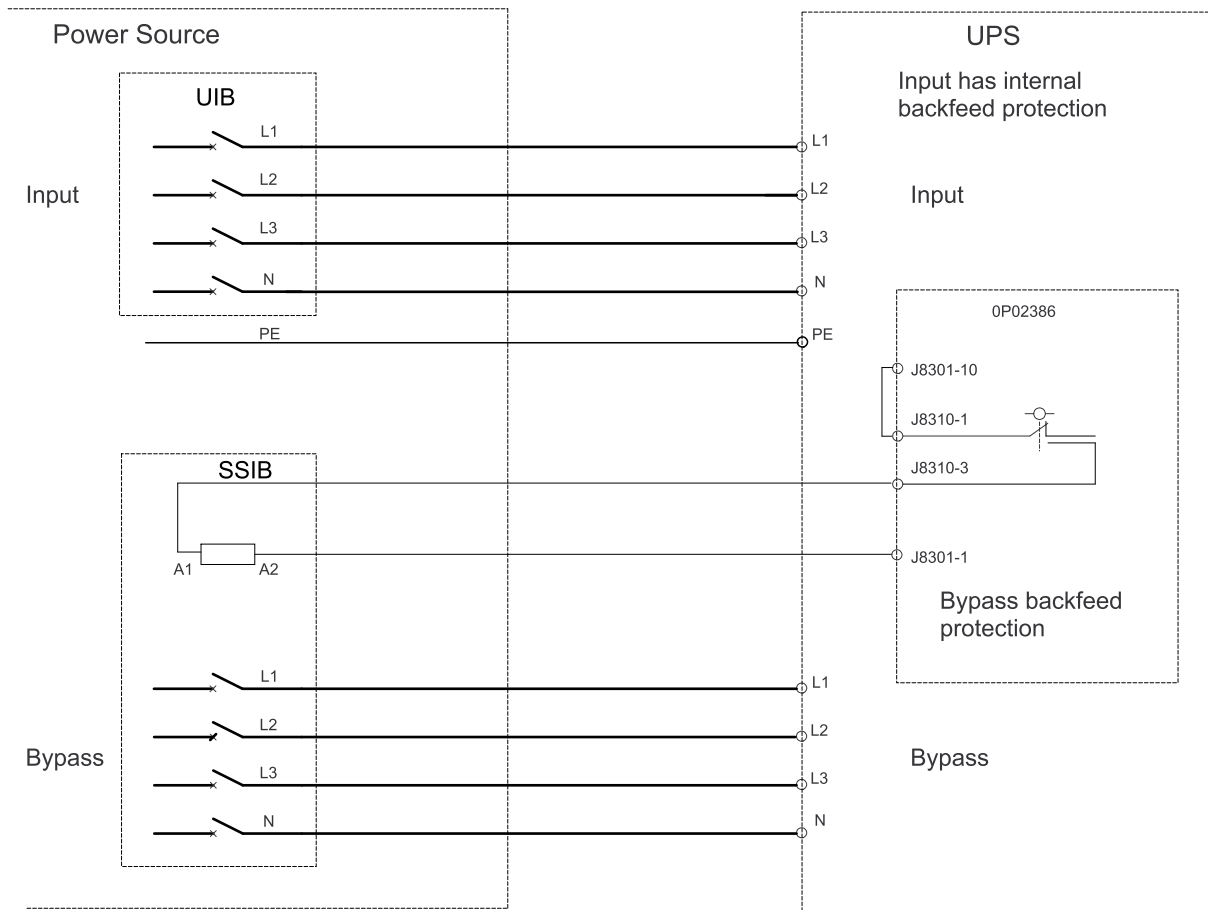

# Final Installation

1. Reinstall the cover over the signal connection terminals.

## Front View of the UPS

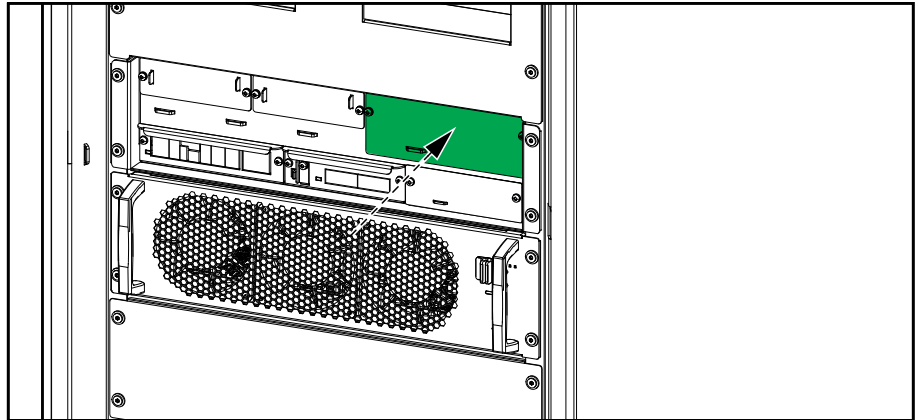

2. Reinstall the front inner cover(s) on the UPS.

### UPS with One Internal Switch

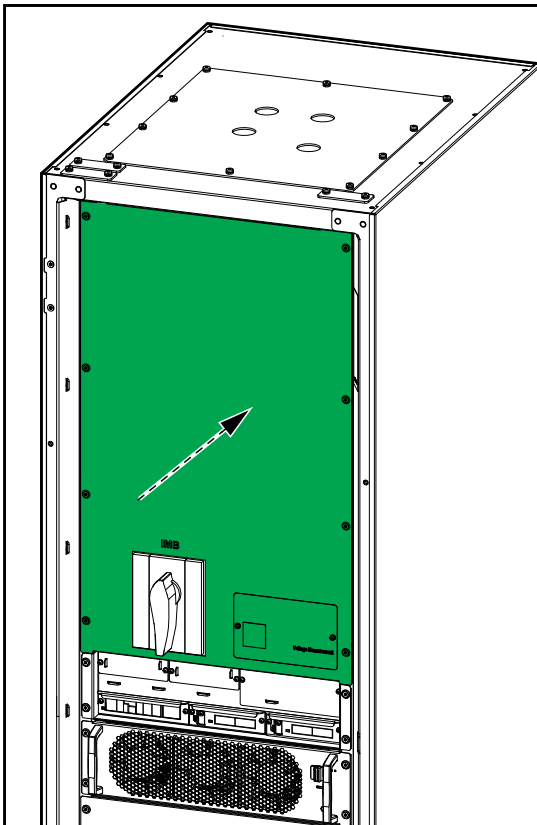

### UPS with Four Internal Switches

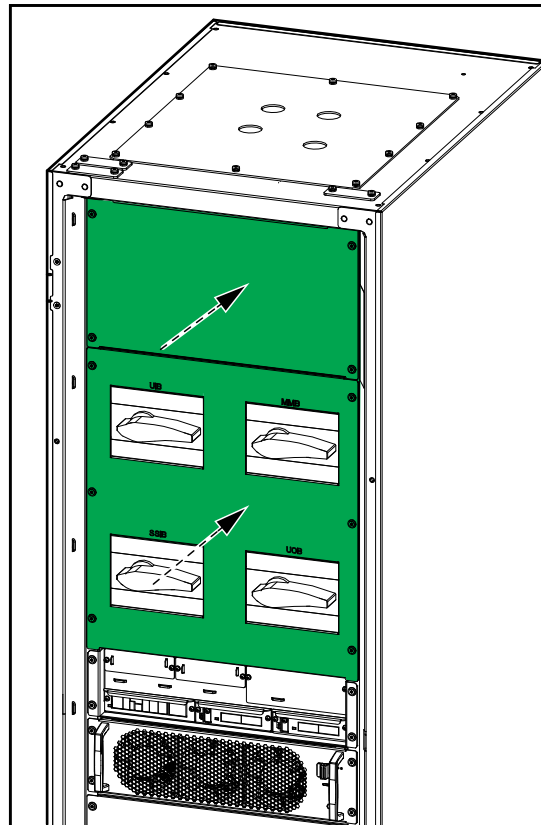

3. Fill out the model-specific power rating information on the UPS name plate.

Model installed:
_____ V _____ kW/kVA
Name of installer:
_____
Note: Refer to the type specifications label or the installation manual for nominal currents for all kW/kVA sizes.

4. Remove the labels 885-92827(x 2) and 885-92828 (x 1) from the top dust covers.

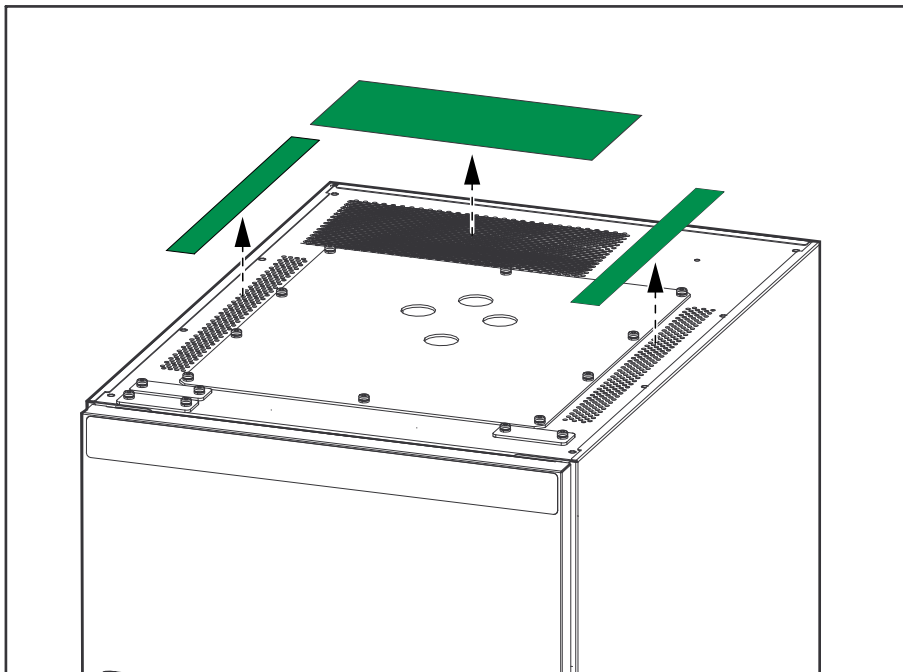









Schneider Electric  
35 rue Joseph Monier  
92500 Rueil Malmaison  
France

+ 33 (0) 1 41 29 70 00



As standards, specifications, and design change from time to time,  
please ask for confirmation of the information given in this publication.

© 2022 – 2022 Schneider Electric. All rights reserved.

990-6538-001