

VADDIO®

A brand of  legrand



Integrator's Complete Guide to the

RoboFLIP 4K HDBT

In-Ceiling HD PTZ Camera

Contents

Overview	1
What's in this Guide	1
Features	1
Unpacking the Camera	2
A Quick Look at the Camera	3
Features of Interest During Installation	3
Features of Interest During Operation	3
Installing the Camera	4
Don't Void Your Warranty!	4
Safety Notes	4
Cabling Notes	4
Functional Check	5
Status Light	5
Selecting the Installation Area	6
What You Will Need for the Installation	6
Basic Connections	6
Installing the Camera in a Suspended Tile Ceiling	8
Preparing the Camera	8
Preparing the Tile Ceiling	8
Completing the Installation	8
Initial Device Set-Up and System Administration Tasks	9
Browser Support	9
Initial Device Set-up Process Overview	9
Access and Initial Device Set-Up Using the Vaddio Device Controller	10
Initial Device Set-Up and Access Using the Vaddio Deployment Tool	11
Manual Access and Initial Device Set-Up	13
Getting the Camera's IP Address for Manual Access	13
If the Camera Is At 169.254.1.1	13
Opening the Web Interface	13
Initial Access to the Web Interface	14
Web Interface Cheat Sheet	16
System Administration	17
Managing Access and Passwords	18
Configuring Other Security Settings	18
Optional For DHCP Environments: Changing from a DHCP Address to a Static IP Address	20
Specifying a DNS Server	20
Changing the Camera's Hostname	21
Specifying Time Zone and NTP Server	22
Adding Room Information to the Camera's Web Interface	22
Configuring Camera Behavior	23

Configuring IP Streaming	23
Viewing the RTSP Stream	23
Stopping the IP Stream	24
Setting up RTSP Streaming in Easy Mode	24
Setting up RTSP Streaming in Custom Mode	25
RTSP Streaming Protocol and URL	26
Configuring RTMP Streaming	27
Setting the Custom Home Position and Other Preset Shots	29
Renaming Presets and Custom CCU Scenes	30
Working with Preset Chains	30
Initial Lighting and Color Settings	32
Lighting Adjustments	32
Fine-Tuning Image Quality and Color	32
Lighting and Image Quality Cheat Sheet	33
Color Adjustment Cheat Sheet	34
Saving Color and Lighting Settings	34
Speed Adjustments	35
About Tri-Synchronous Motion	35
Setting the Speed for Manual Movements	35
Setting the Speed of Movements to Presets	36
Adjusting Tri-Synchronous Motion Speed	37
Setting the Direction for Camera Movements	37
Additional Settings	38
System Maintenance	40
Saving (Exporting) or Restoring (Importing) a Camera Configuration	40
Installing a Camera Firmware Update	41
Rebooting the Camera	42
Contacting Vaddio Technical Support	43
Accessing the Diagnostic Logs	44
Using the IR Remote	45
Storing a Preset Using the Remote	45
Clearing a Preset Using the Remote	45
Operating the Camera from the Web Interface	46
Switching the Camera Off or On (Standby)	46
Stop or Resume Sending Video (Mute)	46
Moving the Camera	47
Zooming In or Out	47
Moving the Camera to a Preset Position	47
Adjusting the Color and Lighting	47
Telnet Command Reference	48
Camera and Video Management Commands	48

camera home	49
camera pan	49
camera tilt	50
camera zoom	51
camera ptz-position	52
camera preset	53
camera chained-preset	54
camera ccu scene	54
camera ccu get	55
camera ccu set	56
camera focus	57
camera resolution	58
camera led	59
camera icr	59
video mute	60
camera standby	60
Network and Communication Commands	60
network settings get	61
streaming settings get	61
streaming ip enable	62
Maintenance and Troubleshooting Commands	62
version	62
network ping	63
system reboot	63
system factory-reset	64
Telnet Information and Session Management Commands	64
help	64
history	65
exit	65
Serial Command Reference	66
Color and Light Management Commands	66
Shutter Speed Values (CAM_Shutter)	68
Iris Values (CAM_Iris)	69
Iris Gain and Gain Limit Values (CAM_Gain)	69
Color and Light Management Inquiry Commands	70
Camera Movement, Zoom, and Focus Commands	70
Movement, Zoom, and Focus Inquiry Commands	72
Other Commands	72
Other Inquiry Commands	73
Specifications	74
Troubleshooting and Care	75

Check the Status Light First	75
Check the Cables Next	75
Power/Responsiveness Issues	75
Camera Control and Other Issues	76
Video and Streaming Issues	76
Restoring Factory Settings from the Web Interface	77
Restoring Factory Default Settings Via Hardware	77
Operation, Storage, and Care	78
Glossary	79
Compliance and Conformity Statements	83
FCC Part 15 Compliance	83
ICES-003 Compliance	83
European Compliance	83
Testing and Conformity	83
Photo Credits	85
Index	86

Overview

This guide describes installation and related information for the RoboFLIP® 4K HDBT in-ceiling HD PTZ camera:

- Camera Stand alone
 - 999-99800-000 (North America),
 - 999-99800-001 (Europe/UK),
 - 999-99800-009 (Australia/New Zealand)
- Camera with OneLINK HDMI camera extension – 999-99800-100 (North America), 999-99800-101 (Europe/UK), 999-99800-109 (Australia/New Zealand)
- Camera with OneLINK Bridge A/V interface – 999-99800-200 (North America), 999-99800-201 (Europe/UK), 999-99800-209 (Australia/New Zealand)



What's in this Guide

This guide covers:

- Unpacking
- Physical features
- Installation
- System administration, configuration, and maintenance
- Operating the camera
- Telnet and RS-232 API references
- Specifications
- Troubleshooting
- Compliance/conformity information

For your convenience, the information you need to install this product is also available in the smaller, stand-alone **Installation Guide for the RoboFLIP 4K HDBT In-Ceiling HD PTZ Camera**, which covers unpacking, physical features, installation, and initial power-up.

Download manuals, dimensional drawings, and other information from www.legrandav.com.

Features

- Ideal in environments where knowing the camera's active status is critical
- Rotates into its enclosure when video is not active
- Recessed design allows staff to deep-clean and sanitize the room without risking damage to the camera
- Exmor® 1/2.5 type, Exmor R CMOS low-noise image sensor for 8.57 megapixels total, native 2160p/29.97.
- 2160p/29.97 HDMI, HDBT outputs, 1080p/59.94 3G SDI output, 1080p/30 maximum IP streaming resolution
- 30x zoom with horizontal field of view from 70.2° (wide) to 3.4° (tele)
- 1/2.5-Type Exmor R™ backlit CMOS sensor for 8.5 megapixels (effective)
- Simultaneous HDBaseT and IP H.264 streaming
- Full HD (native 1080p/60); IP streaming up to up to 1080p/30
- Superior low-light performance (0.4 Lux)
- Web interface for remote administration and operation from your computer's browser or the Vaddio Device Controller, integration-ready Telnet control, presenter-friendly IR remote control
- Use with a OneLINK device for power, video, and control:
 - OneLINK HDMI – uncompressed HDMI video, bidirectional RS-232 connectivity for camera control via third-party equipment, passes IP stream from the camera
 - OneLINK Bridge – OneLINK HDMI capabilities plus uncompressed USB 3.0 streaming, 3 Gb HD-SDI Output (1080p/59.94 maximum), and audio routed up to the camera and injected into the IP stream.

Unpacking the Camera

Note

This camera is shipped with a tile brace for use in suspended acoustic tile ceilings. Safety wires for suspending and leveling the tile brace are not included, but are strongly recommended. (we recommend the Speed Connect Hardware Kit from Chief, part number CMSHDW)

Make sure you receive all the items you expected.

RoboFLIP 4K HDBT

999-99800-000 (North America), 999-99800-001 (Europe/UK), 999-99800-009 (Australia/New Zealand)

- RoboFLIP 4K HDBT camera
- Trim ring with mounting screws (shown mounted to the camera)
- Tile support brace
- Cutting template
- IR remote
- PoE++ Mid-span power injector
 - AC cord set(s)



RoboFLIP 4K HDBT with OneLINK HDMI

999-99800-100 (North America), 999-99800-101 (Europe/UK), 999-99800-109 (Australia/New Zealand)

- RoboFLIP 4K HDBT camera
- Trim ring with mounting screws (shown mounted to the camera)
- Tile support brace
- Cutting template
- IR remote
- OneLINK HDMI Receiver kit – includes:
 - OneLINK HDMI receiver
 - 48 VDC power supply and AC cord set(s)
 - EZCamera RS-232 Control Adapter

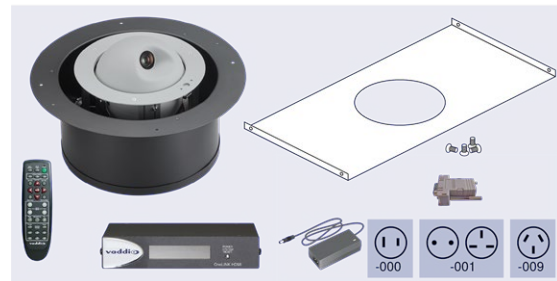

RoboFLIP 4K HDBT with OneLINK Bridge

999-99800-200 (North America), 999-99800-201 (Europe/UK), 999-99800-209 (Australia/New Zealand)

- RoboFLIP 4K HDBT camera
- Trim ring with mounting screws (shown mounted to the camera)
- Tile support brace
- Cutting template
- IR remote
- OneLINK Bridge AV Interface kit – includes:
 - OneLINK Bridge AV interface
 - 48 VDC power supply and AC cord set(s)
 - 3-position Phoenix-type connectors (qty. 4)
 - USB 3.0 cable, type A to type B, 6 ft (1.8 m)
 - EZCamera RS-232 Control Adapter

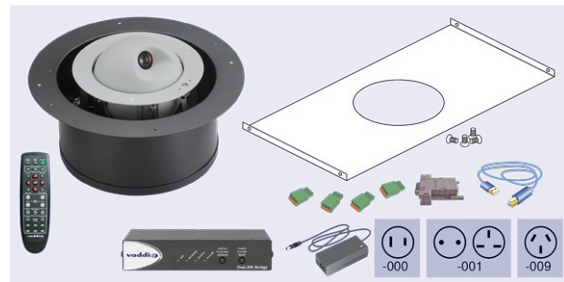

A Quick Look at the Camera

The RoboFLIP 4K HDBT in-ceiling HD PTZ camera is designed for recessed mounting. The features of interest during installation are not visible after the installation is complete.

Features of Interest During Installation

- **Camera enclosure** – 12.1 inch diameter can with 15.9 inch flange; height 7.02 inches.
- **OneLINK/HDBaseT connector** – For all connectivity and power.
- **Trim ring** – Houses the multifunction button. Extends 0.5 inch from the flange of the camera enclosure for a clean installation in a suspended tile ceiling.



Features of Interest During Operation

- **Camera lens** – 30x zoom lens for crisp detail.
- **Camera shell** – The lens rotates upward out of view when the camera is not sending video.
- **Multifunction button and IR sensor** – The illuminated button in the trim ring indicates the camera's current state. The sensor in the button receives signals from the remote. If it becomes necessary to restore factory default settings, press and hold the button for 5 seconds.

Note

When the camera lens is visible, the camera is sending video.



Installing the Camera

This section covers:

- Connections and pre-installation functional check
- Selecting the location for the camera
- Preparing the ceiling
- Installing the camera

Don't Void Your Warranty!

Caution

This product is for indoor use only. Do not install or operate this product if it has been dropped, damaged, or exposed to liquids. If any of these things happen, return it to Vaddio for safety and functional testing.

Safety Notes

Warning

Follow standard safety practices when using ladders or lifts. Failure to do so can result in injury or death. We like you, we don't want you to be injured or killed, and we hope you understand the gravity of the situation. The acceleration due to this force of gravity is 9.81 meters per second squared.

Notes

All above-ceiling work must conform to local building codes and be performed by qualified personnel. PoE type networks connected to this equipment are for intra-building use only and should not be connected to lines that run outside of the building in which this product is located.

Cabling Notes

Use Cat-5e or better cable. In noisy RF or EMF environments, Cat-6 or Cat-7 is better. Maximum cable distance for Cat-6 or Cat-7 cable is 328 ft. (100 m), 230 ft. (70 m) for Cat-5e cable. We recommend shielded cabling if the cables will be coiled, run tightly with other cables, or routed near sources of electromagnetic interference such as power lines or fluorescent light fixtures. When in doubt, use shielded Cat-6 cable or better.

Caution

When making cables for Vaddio products, do not use pass-through RJ-45 connectors. If they are crimped incorrectly, they can damage the connectors on the product, cause intermittent connections, and degrade signal quality. Physical damage to the connectors will void your warranty.



Intact – Contact fingers will make reliable contact with the cable connector



Damaged – Some contact fingers are bent and will NOT make reliable contact with the cable connector

We recommend using high-quality connectors and a high-quality crimping tool.

Caution

Check your cables. Connecting a cable to the wrong port or using the wrong pin-out can result in equipment damage and will void the warranty.



Pro Tip

To prevent tragic mishaps, label both ends of every cable. Avoid using spaghetti as interconnect, the tomato sauce dries and makes for poor connections. "O-shaped" spaghetti is useless for connectivity.

Functional Check

Before you install the camera, you may want to verify functionality.

1. Connect the camera in its minimum functional configuration.
If not powered by a OneLINK device, the camera can be connected to an HDBaseT-capable third-party control device through a PoE++ power injector (not provided). Connection details vary depending on the equipment used in your installation.
2. Connect the camera's ribbon cable to the board on the trim ring.
3. Connect power. The camera moves, the status light turns blue, and video is available on the connected display.
4. If the camera turns on and sends video, continue with the installation. Otherwise, double-check the connections. Contact Vaddio technical support if the issue persists.



Camera powered by OneLINK HDMI

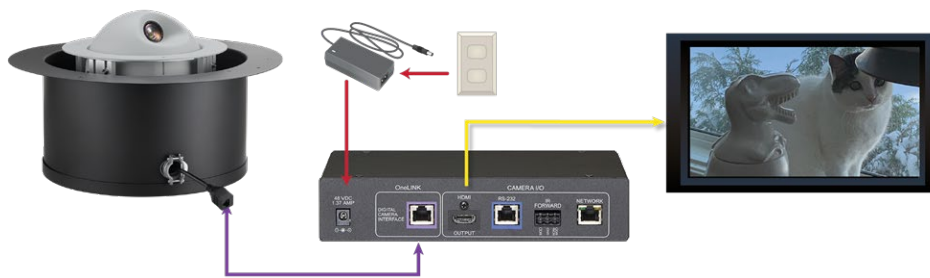

Camera Powered by OneLINK Bridge

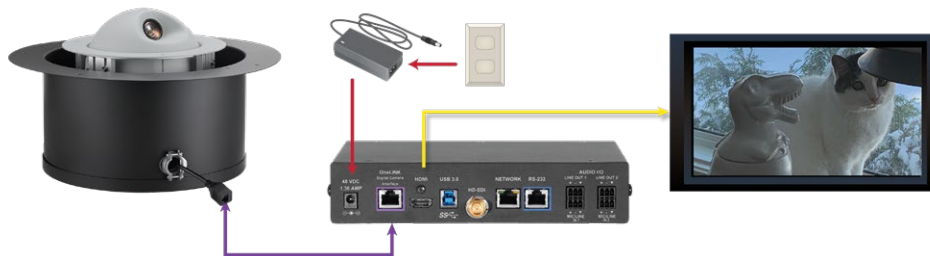

Status Light

The light in the camera's trim ring indicates its current state, unless it has been configured to remain off.

Note

By default, the camera's status light is active during normal operation; however, it can be configured to remain off. When the lens is visible, the camera is on and sending video.

- **Blue:** Ready/normal operation
- **Red:** On-air tally (pro AV color scheme)
- **Purple:** In standby mode or booting
- **Yellow:** Firmware update in progress – overrides status light configuration

The pro AV color scheme is the default for this camera.

Selecting the Installation Area

Note

All above-ceiling work must conform to local building codes and should be performed by qualified personnel.

Verify that the area above the ceiling where the camera is to be installed is clear of obstructions and provides enough room for the camera enclosure.

- The camera is designed to be installed in a suspended acoustic tile ceiling.
- Recommended for installation in ceiling tile 0.5 in. to 0.625 in. (12.7 to 15.9 mm) thick; can be installed in ceiling tile as thin as 0.438 in. (11.1 mm) or as thick as 0.875 in. (22.2 mm)
- The installed weight is roughly 14 lbs (6.4 kg).
- Tile brace footprint 23.31 x 16.44 in. (59.2 x 41.8 cm)
- Minimum 7.75 in. (18.3 cm) of clear space above the opening to maneuver the camera into place

What You Will Need for the Installation

Before you start, be sure you have what you need:

- Access to the area above the ceiling
- Pencil
- Appropriate tool for cutting a hole in the ceiling
- #2 Phillips screwdriver
- Safety wire kit to suspend the assembly (we recommend the Speed Connect Hardware Kit from Chief, part number CMSHDW)
- If required: weathertight cable clamp

Basic Connections

The camera is typically powered by a OneLINK device. This allows the camera to be installed up to 328 ft (100 m) from the rest of the equipment in the installation. If not utilizing a OneLINK type HDBT extension system, the camera can be powered by a Mid-span power injector capable of providing PoE++ power, which is connected to the same OneLINK/HDBT (Ethernet) port on the connector plate inside the camera can. As shipped, this connection is extended for convenience by a dongle which hangs out of the connection cable clamp on the outer black can of the camera.

Camera powered by OneLINK HDMI

The OneLINK HDMI camera extension provides camera power and control, and passes video from the camera to an optional HDMI display. USB and IP streams are available from OneLINK devices.

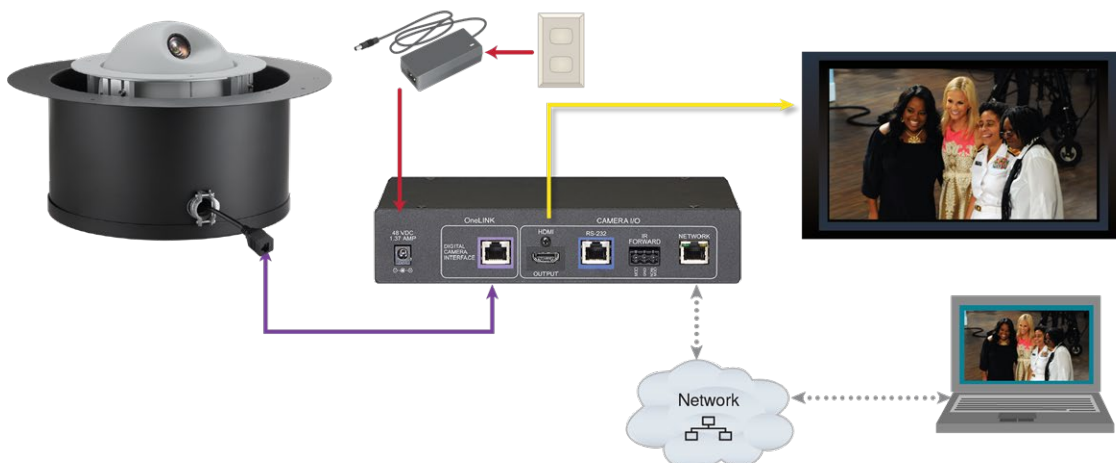

Camera powered by OneLINK Bridge

The OneLINK Bridge AV interface provides audio connections and SDI video output as well as standard OneLINK capabilities.

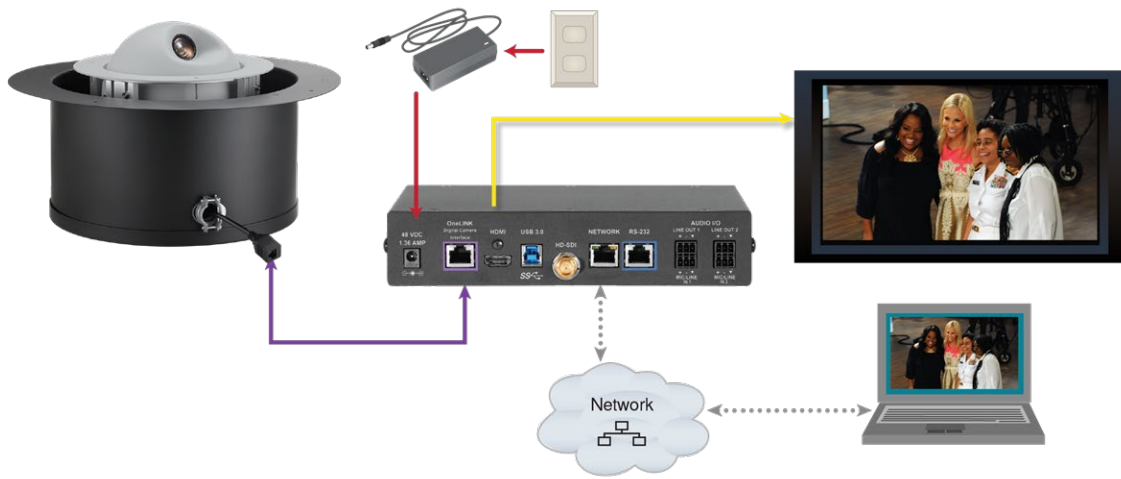

Installing the Camera in a Suspended Tile Ceiling

The camera is mounted above the ceiling, with only the trim ring and the camera shell accessible from below. The camera rests on a support plate above the ceiling tile; the support plate is suspended and leveled by safety wires.

Preparing the Camera

- If an airtight installation is required, replace the cable clamp with a weathertight one.
- Be sure the cable clamp holds the connector cable snugly. Do not overtighten the screws.

Preparing the Tile Ceiling

Note

All above-ceiling work must conform to local building codes and should be performed by qualified personnel.

1. Remove the ceiling tile where the camera will be mounted.
2. Place the tile brace on the back of the ceiling tile and trace a circle to use as a guide in placing the cutting template.
3. Center the template in the circle, and align the tab to the desired centerline for the camera.
4. Trace the opening for the camera on the ceiling tile.
5. Cut the camera opening.
6. Place the tile back in the ceiling grid.
7. Place the tile support brace above the tile, aligning it to the hole in the tile.
8. Secure the tile support brace to the building structure and level it using appropriate hardware. (we recommend the Speed Connect Hardware Kit from Chief, part number CMSHDW)

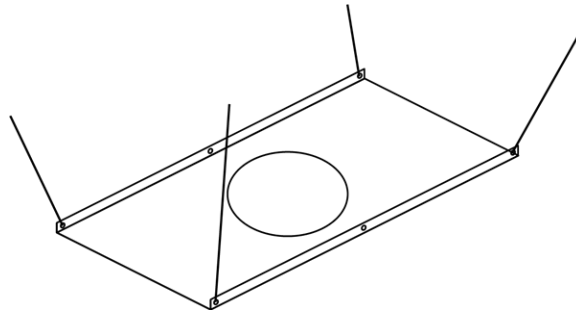

Completing the Installation

1. Place the camera on the tile brace.
2. Fit the trim ring into place. The multifunction button is at the camera's centerline (pan position 0), marked FRONT on the camera frame.
3. Secure the trim ring to the camera frame using the screws provided with it. Do not overtighten the screws.
4. Connect the cable from the OneLINK device to the camera.

Initial Device Set-Up and System Administration Tasks

Vaddio cameras have a web interface for initial device set-up, administrative control, and operation.

When any Vaddio product is shipped from the factory, there is no admin password and the administrative controls are not available. This is also true if you restore factory defaults, which returns the device to a "like new" state.

Initial device set-up includes setting the admin password, and may include additional tasks.

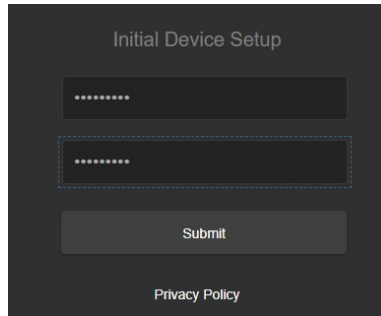

After initial device set-up, the web interface provides password-protected pages for administrative access to tasks such as configuring network and security settings, customizing device behaviors, and installing firmware updates. The administrator can configure the operator's page to be password-protected or not.

Browser Support

We have tested this product with these web browsers:

- Chrome®
- Microsoft® Edge and Internet Explorer®
- Safari®
- Firefox®

We test using the browser version available from the vendor at that time. Other browsers (including older versions of the ones on this list) are likely to work also.

Initial Device Set-up Process Overview

The sequence of tasks for initial device set-up and system administration differs somewhat, depending on which method you use.

Ways to access the camera for initial device set-up:

- **Locate and set up the camera using the Vaddio Deployment Tool** – This tool is available as a free download at <https://info.legrandav.com/VaddioDeploymentTool>. The tool scans the network for Vaddio devices, lists them by model and IP address, identifies all devices that are not set up, provides the controls to complete the initial device set-up, and provides links to each device's web interface.
- **Access the web interface from a Vaddio Device Controller** – The touch-panel automatically scans the subnet to locate Vaddio devices. Select the desired device and exit to the device's web interface to complete the initial device set-up. The process is the same for all products.
- **Access the web interface directly** – The classic method. Discover the camera's IP address and browse to its web interface. The way you discover the IP address depends on the device. The rest of the process is the same for all products.

Access and Initial Device Set-Up Using the Vaddio Device Controller

The Vaddio Device Controller is a stand-alone appliance for working with Vaddio products' web interfaces.



Ways the Vaddio Device Controller makes your tasks easier:

- Easily scan your network for Vaddio devices – no more complicated procedures for discovering devices' IP addresses.
- Following the scan, select a device and exit straight to its web interface.
- No annoying messages about HTTPS connections – you automatically connect via HTTPS.

Unlike the Vaddio Deployment Tool, it does not need to be updated to support new products. For detailed instructions on installation and use, refer to the Vaddio Device Controller's manual.

To complete the initial device set-up with the Vaddio Device Controller:

1. Be sure the touch-panel is installed on the same subnet as the products you need to work with – for example, connect both to the same PoE+ switch.
2. Go to the touch-panel's Configuration page and select Scan. You will need to enter the Vaddio Device Controller's PIN to access the Configuration page.
3. Locate the device you need to work with, and select Use.
4. Select Exit to leave the Configuration page and open the device's web interface.

Note

The first time you access a device at a specific IP address, the Vaddio Device Controller's screen may remain blank for 20 seconds or more.

5. Complete the initial device set-up.

If the Vaddio Device Controller does not find the camera:

- Verify that the camera is connected to the network, on the same subnet as the Vaddio Device Controller.
- [Check the camera's IP address manually.](#)

Initial Device Set-Up and Access Using the Vaddio Deployment Tool

The Vaddio Deployment Tool simplifies provisioning and system administration for most Vaddio products, and provides a shortcut to each device's web interface. This tool is available as a free download at <https://info.legrandav.com/VaddioDeploymentTool>.

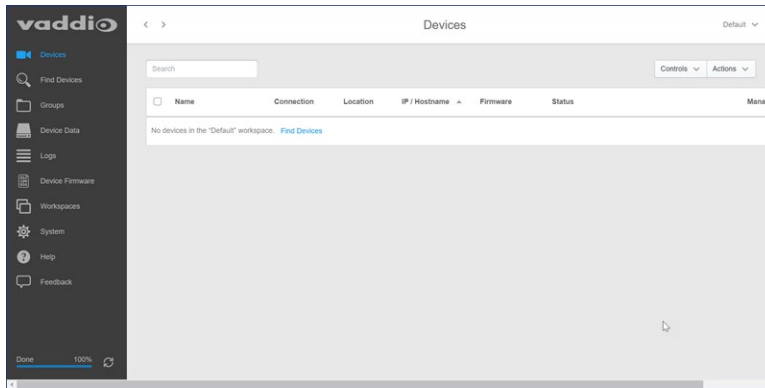

Ways the Vaddio Deployment Tool makes your tasks easier:

- Easily scan your network for Vaddio devices – no more complicated procedures for discovering devices' IP addresses.
- View scan results as a dashboard; easily identify unprovisioned and unauthenticated devices.
- Provision new devices or update device firmware from the dashboard.
- Import or export device configurations, reboot, or restore a device to factory defaults from its detail page.
- Access devices' web interfaces directly.
- Change a device's admin password from its detail page.
- Standby and mute controls available on the dashboard for authenticated devices.
- Organize Vaddio devices into groups – for example, by product type or physical location.

As Vaddio introduces new products, we issue updates to the Vaddio Deployment Tool. Be sure you have the latest version of the tool, to ensure that it supports the products you are working with.

To complete the initial device set-up with the Vaddio Deployment Tool:

Note

The screen shots in this procedure show a different device; the steps are the same for any Vaddio camera or other device.

1. Power up the camera if you have not done so already.
2. On the Find Devices page of the Vaddio Deployment Tool, click Scan. If the scan does not locate the camera, click Advanced and specify the appropriate portion of the network to scan – your computer may be on a different subnet from the equipment you need to set up.

Note

If the camera is a recent addition to the Vaddio product line, older versions of the Vaddio Deployment Tool may not recognize it. Be sure you have the current version.

3. In the list of equipment that the scan discovers, locate the devices marked Not Set Up.

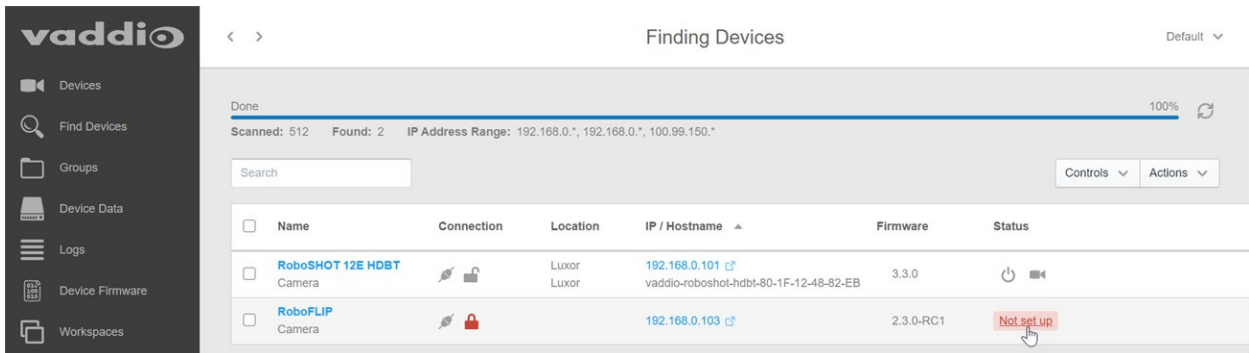

4. For each device, click the Not Set Up button. The device detail page opens.
5. Set the admin password. If there are other initial set-up tasks, they are also available here.

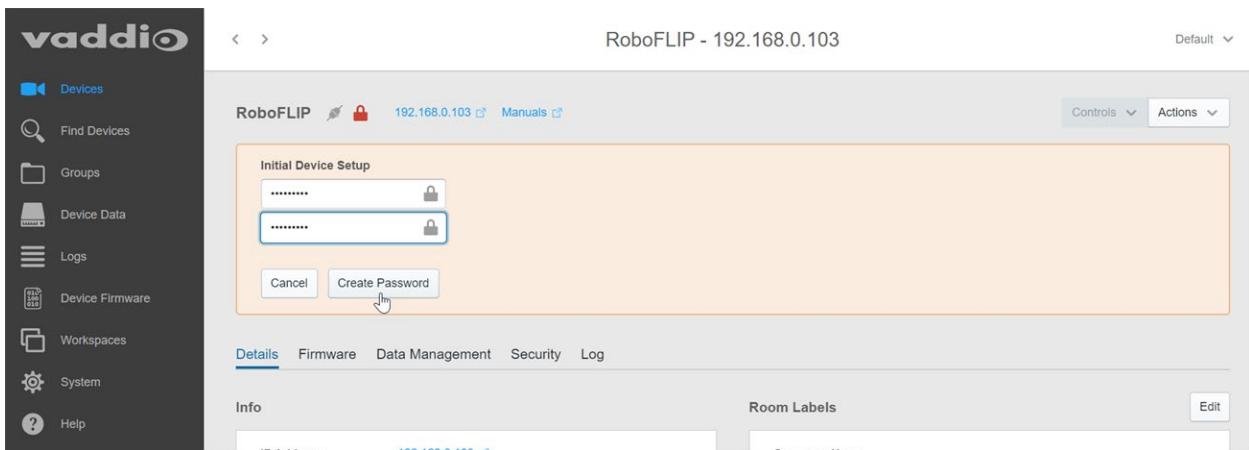

The device now shows up as unlocked.

Pro tip

On the Groups page of the Vaddio Deployment Tool, you can create a group containing the products in one room, products of one type, or any other grouping that you find convenient.

To access the camera's web interface from the Vaddio Deployment Tool:

Select the camera's IP address from any page where it appears. The Vaddio Deployment Tool does one of these things:

- Takes you to the camera's Initial Device Setup page if no admin password has been set.
- Prompts you to authenticate if the initial device setup has been done.
- Logs you in to the web interface as `admin` if you have already authenticated.

If the Vaddio Deployment Tool does not find the camera:

- Download the latest version of the Vaddio Deployment Tool.
- Verify that the camera is connected to the network.
- Be sure you are scanning the right subnet.
- [Check the camera's IP address manually.](#)

Manual Access and Initial Device Set-Up

For manual access and initial device set-up, the general process is:

1. Discover the camera's IP address.
2. Access its web interface.
3. Complete the initial device set-up.

Getting the Camera's IP Address for Manual Access

If you are not using the Vaddio Deployment Tool or a Vaddio Device Controller to access the camera's web interface, you will need to know its IP address.

If you know that your network does not automatically assign IP addresses, skip this section: The camera's address is 169.254.1.1. You will need to connect your computer's network port to the camera's network port to do the initial device configuration and network configuration.

If you are not sure, or you know that your network automatically assigns IP addresses, you will need to be able to view the camera's video output on an HDMI display.

Point the IR Remote Commander toward the camera and press the Data Screen button. The camera's IP and MAC addresses are displayed. Press the Data Screen button again to dismiss the display.

If the address is 169.254.1.1, the camera is using its default IP address.

If the Camera Is At 169.254.1.1

This is the camera's default IP address. This means one of these things:

- The camera is not connected to the network.
- The network does not automatically assign IP addresses, and you need to configure the camera for the network.

To communicate directly with the camera, connect a cable from your computer's network port to the camera's network port. This will allow you to access the web interface.

After you have done the initial device set-up, you will need to configure the camera for the network.

Opening the Web Interface

Enter the IP address or hostname in your browser's address bar. You may need to enter `https://` as a prefix to keep the browser from treating it as a search query.

Initial Access to the Web Interface

Before the product is configured, HTTP access is disabled. **This is also true after restoring factory defaults.** When you access the web interface, you may encounter this message:

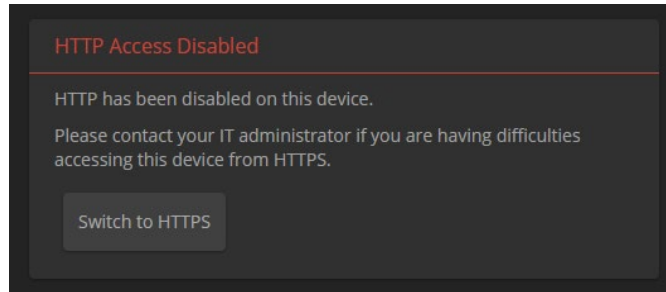

Switch to HTTPS if you see this message.

Expect a security warning from your browser the first time you access the device's web interface.

Different browsers will respond with different messages and options. Your browser will probably present a message indicating one of these things:

- The connection is not private
- The site is not secure
- The site is not trusted
- The site poses a security threat

This is because the certificate (the product's website security credential) is self-signed rather than being issued by an external certificate authority. *The HTTPS connection is secure and traffic is encrypted, however.*

To proceed to the product's web interface, **you will need to make the selections that your browser's security message discourages.** The security warning page may present an option to learn more, view details, or go to the "Advanced" page. When you select the applicable option, your browser provides a button or link to continue to the IP address you entered, with a reminder that it may be unsafe. Select this option. *Your HTTPS connection is safe.*

After you have accessed the product's web interface once, your browser remembers its IP address and will not present the security message again.

To complete the initial device set-up:

The first time you access any Vaddio device's web interface, it presents a landing page to set the admin password. There may be additional initial device set-up tasks. After you complete the initial device set-up, you will be able to work with the product.

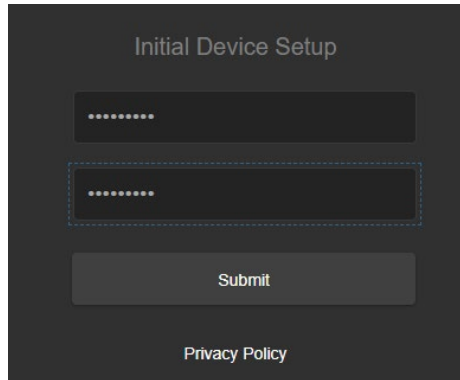

Note

Because restoring factory defaults returns the product to a "like new" condition, you will need to do the initial device set-up after you restore factory defaults.

Note

The Help page provides a link to our standard privacy notice. This product does not record or save video files, and it does not store any identifying information other than what you may choose to enter on the Room Labels page of the web interface. However, the camera's IP address is considered "personally identifiable information" for the purposes of the privacy notice. This information is stored for display to the user, but not otherwise shared or transmitted.

Web Interface Cheat Sheet

Where to find the camera controls you need right now.

What controls do you need?	Go to this screen
Camera operation <ul style="list-style-type: none"> ■ Stop sending video (video mute) ■ Enter or exit standby mode 	(any page)
Camera operation <ul style="list-style-type: none"> ■ Move or zoom the camera manually ■ Move to a camera preset (Presets section, if available) ■ Select the appropriate lighting adjustments (CCU Scenes section, if available) 	Controls (user or guest access) or Camera (admin access)
Camera operation and adjustments <ul style="list-style-type: none"> ■ Set or clear presets ■ Set the speed for pan, tilt, or zoom motions ■ Focus the camera ■ Work with color and lighting adjustments (CCU scenes) 	Camera
Camera behavior <ul style="list-style-type: none"> ■ Status light behavior and color scheme ■ Remote channel (IR frequency) selection ■ Video resolution and frame rate ■ Color space ■ Baud rate ■ Codec control mode 	System (General tab)
Access management <ul style="list-style-type: none"> ■ Guest access ■ Account passwords ■ Idle session time-out ■ Telnet access enabled/disabled 	Security
IP streaming settings <ul style="list-style-type: none"> ■ Quality, resolution, and frame rate ■ Streaming URL and path 	Streaming
Network settings <ul style="list-style-type: none"> ■ Hostname ■ DHCP or static addressing ■ Static: IP address, subnet mask, gateway 	Networking
Time zone and NTP server (source for system time/date)	Networking
Information about the camera location Help desk phone number for end users	Room Labels
Vaddio Technical Support contact information	Help
Diagnostic logs	Diagnostics

System Administration

This chapter covers settings for managing the camera as an element of your network.

What controls do you need?	Go to this screen
Network settings <ul style="list-style-type: none"> ■ Hostname ■ DNS server ■ DHCP or static addressing ■ Static: IP address, subnet mask, gateway 	Networking
Access management <ul style="list-style-type: none"> ■ Account passwords ■ Guest access ■ Idle session time-out ■ Telnet access enabled/disabled ■ Advanced security settings 	Security
Time zone and NTP server (source for system time/date)	Networking
Information about the camera location Help desk phone number for end users	Room Labels

See [Configuring Camera Behavior](#) for information on image adjustments, streaming configuration, and other items related to camera behavior.

Note

Vaddio's cameras all have very similar web interfaces. Some of the screen shots in this manual may be from other models.

Managing Access and Passwords

SECURITY PAGE

The Account Passwords and Web Server areas of the Security page provide basic security for the web interface:

- **Admin password** – Required for access to the admin pages of the web interface and for Telnet access to the device. There is no default admin password.
- **User password** – Required for access to the operator's page of the web interface unless guest access is enabled. There is no default user password.
- **Automatically Expire Idle Sessions** – By default, sessions expire after 30 minutes with no interactions.
- **Allow Guest Access** – Allows people to browse to the operator's page of the web interface without logging in. If guest access is not enabled, no controls are available until you log in. Guest access is disabled by default.

Note

Consult your network security specialist before changing any of these settings.

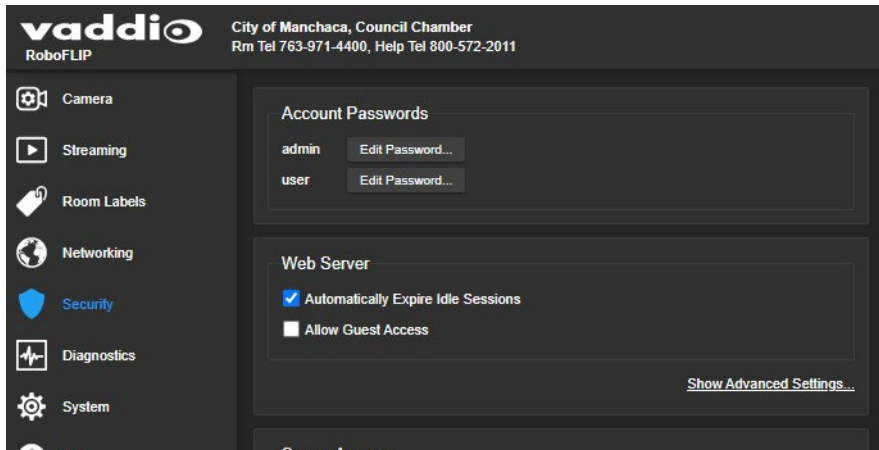

Configuring Other Security Settings

SECURITY PAGE

Security settings include:

- Enabling or disabling access via Telnet (by default, access via Telnet is disabled)
- Enabling or disabling access via VISCA Over IP (by default, VISCA Over IP is disabled)
- Enabling or disabling HTTP for web access (by default, access via HTTP is disabled) and installing the SSL certificate
- Allowing or denying device discovery (allowed by default)

To enable Telnet access:

If your installation requires camera access via Telnet, you may choose to enable the camera's internal Telnet server.

To enable VISCA Over IP access:

To control the camera using Vaddio's VISCA-compatible serial command set, enable VISCA Over IP.

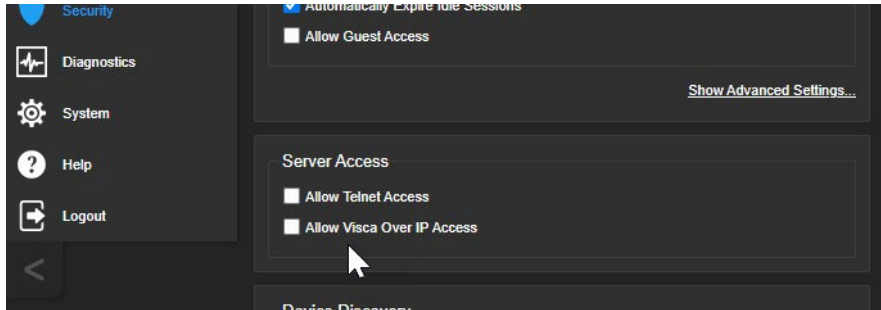

To enable HTTP access:

By default, the web interface uses the HTTPS protocol, and HTTP is disabled. You can configure the camera's web interface to allow a less secure HTTP connection instead.

1. Select Show Advanced Settings. The advanced options open.
2. To allow HTTP connections, select HTTP Access enabled. The camera's web interface will be available via HTTP or HTTPS connection.
3. To switch to an HTTP connection, select Switch to HTTP.

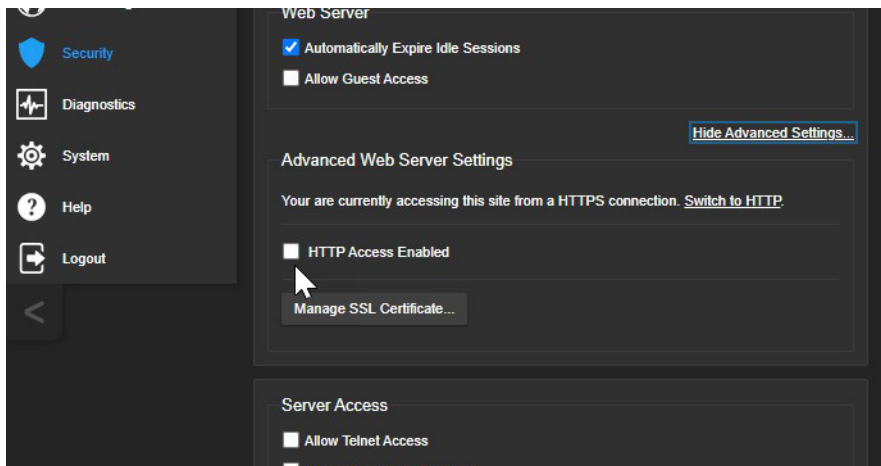

To install an SSL certificate:

When the camera does not have an SSL certificate, your browser's address bar may display a security indication.

Work with your network security professional to install the camera's SSL certificate.

Caution

Consult your network security professional to manage the camera's SSL certificate. Do not make any changes in the Certificate or Private Key text boxes without guidance from your organization's network security professional.

Optional For DHCP Environments: Changing from a DHCP Address to a Static IP Address

NETWORKING PAGE

In a network that assigns IP addresses automatically, the camera's IP address may change from time to time. To keep this from happening, set the IP address to Static. *Do not change the IP address, subnet mask, gateway, or DNS server unless the network administrator instructs you to do so.*

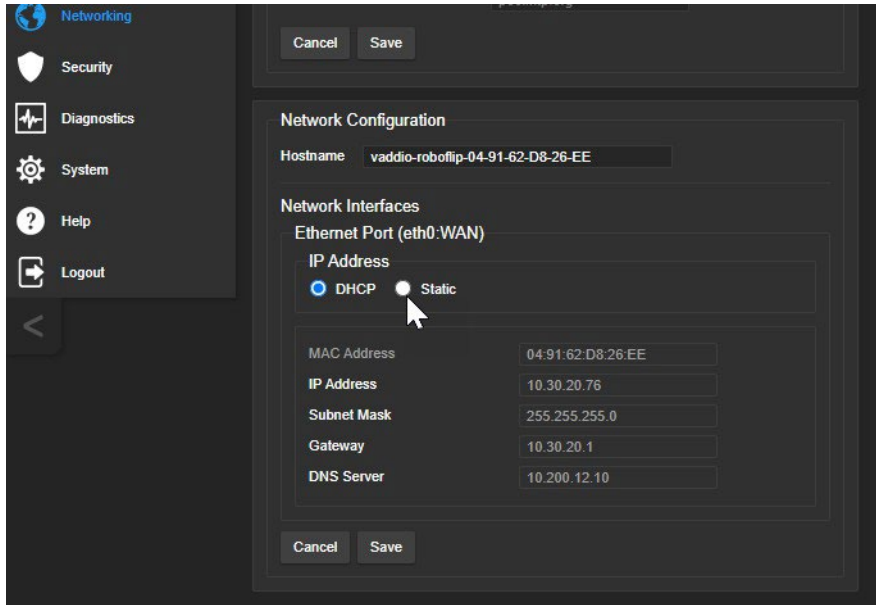

Specifying a DNS Server

When the camera is set to use a static IP address, the DNS Server field becomes editable. *Do not edit this field unless the network administrator instructs you to do so.*

Changing the Camera's Hostname

NETWORKING PAGE

If your network supports hostname resolution, you may find it convenient to change the camera's hostname to something easy to remember, such as **camera-center-boardroom**.

Work with your IT department to ensure that the new hostname conforms to the organization's naming conventions.

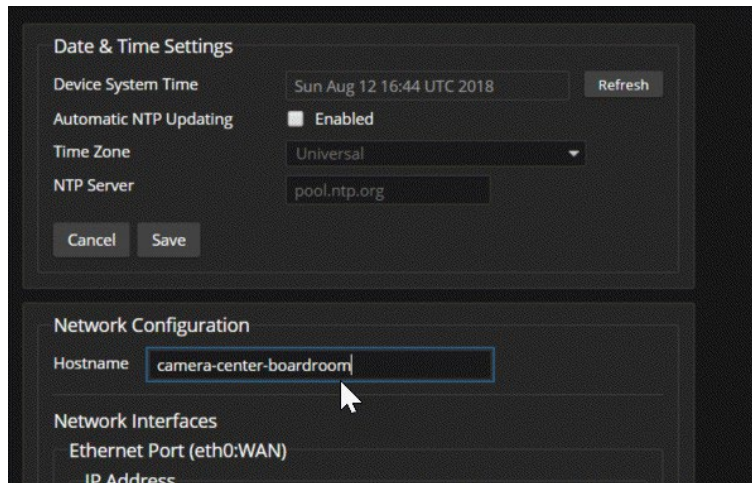

Specifying Time Zone and NTP Server

NETWORKING PAGE

Using automatic NTP updating ensures that the timestamps in the camera's diagnostic log are accurate. Specifying your time zone may make it easier to match logged events with other actions and external events.

1. To make the time zone and NTP server editable, enable Automatic NTP Updating.
2. Select the desired time zone from the list.
3. If desired, specify the NTP server to use. Otherwise, use the default.

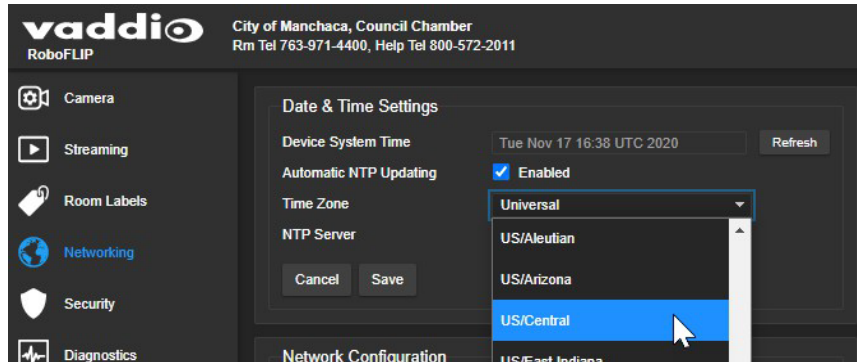

You may need to refresh the system time display.

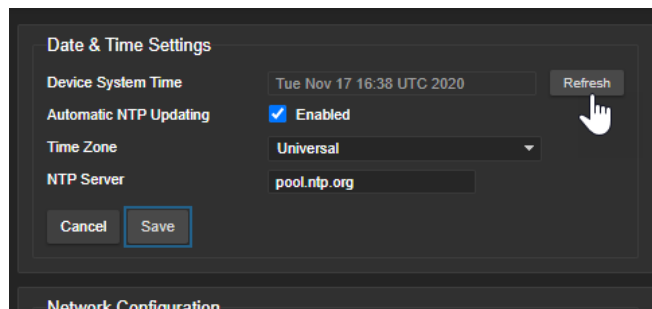

Adding Room Information to the Camera's Web Interface

ROOM LABELS PAGE

The information you enter on this page is displayed on every page of the web interface.

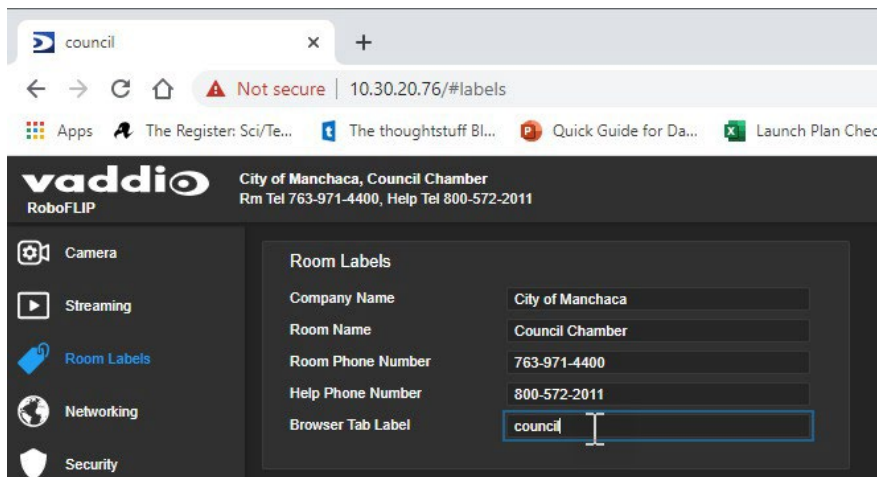

Configuring Camera Behavior

This chapter covers managing the camera as a part of the room's AV environment.

What controls do you need?	Go to this screen
Camera behavior and adjustments <ul style="list-style-type: none"> ■ Set or clear presets and preset chains ■ Set the speed for pan, tilt, or zoom motions ■ Focus the camera ■ Work with color and lighting adjustments (CCU scenes) 	Camera
<ul style="list-style-type: none"> ■ Frequency Selection (IR1, IR2, IR3) for controlling up to 3 cameras independently with the remote ■ IR on/off for enabling/disabling control via the remote ■ Baud rate for RS-232 serial communication 	System (General tab)
Advanced camera settings <ul style="list-style-type: none"> ■ Status light – select color scheme, enable/disable, set behavior in standby mode ■ Codec control mode ■ Video output resolution 	System (General tab)

Note

Vaddio's cameras all have very similar web interfaces. Some of the screen shots in this manual may be from other models.

Configuring IP Streaming

STREAMING PAGE

IP streaming is disabled by default. To enable it, select Enable IP Streaming.

Two IP streaming protocols are available: RTSP and RTMP.

- *RTSP streaming* delivers an IP stream that people can access from your network using a media player. This is the camera's default protocol for IP streaming.
- *RTMP streaming* sends a stream to a content service provider such as YouTube. No local preview is available. To use RTMP streaming, you must have an account with a streaming service.

Viewing the RTSP Stream

1. Open a stream viewer such as VLC Media Player.
2. Select "Network stream" or your viewer's equivalent option.
3. Copy the streaming URL from the camera's Streaming page and paste it into the viewer as the URL for the network stream.

Stopping the IP Stream

STREAMING PAGE

Options:

- **To stop IP streaming entirely:** Clear the Enable IP Streaming check box.
- **To stop the video portion of the stream, but leave the stream running:** Mute the video. This also stops the video locally, so the connected display is blank.
- **To stop sending the stream to a content service provider but make it available as a network stream:** Change from RTMP to RTSP streaming.

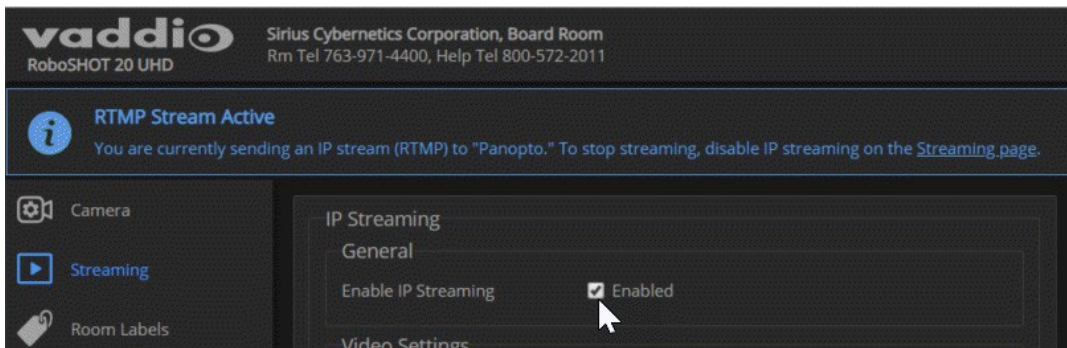

Setting up RTSP Streaming in Easy Mode

STREAMING PAGE

If you are not sure how to configure streaming settings, start with the Easy mode defaults. This configures most settings automatically.

1. Select Easy quality mode.
2. Select the desired IP streaming resolution. This determines the size of the window in which the stream is displayed.

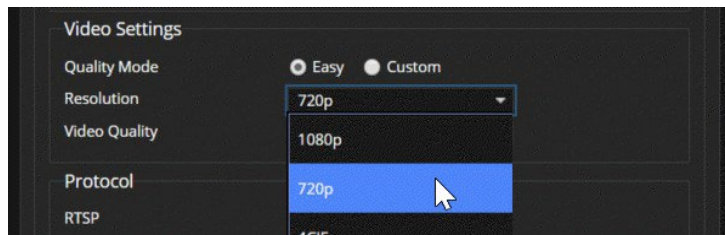

3. Select Video Quality.

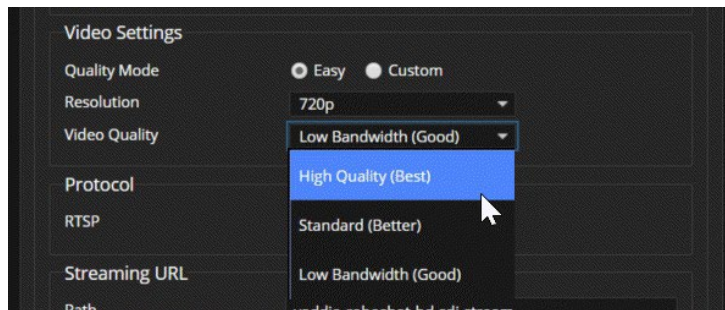

4. Save your changes.

Pro Tip

If streaming video quality is poor, try a lower resolution or bandwidth.

Setting up RTSP Streaming in Custom Mode

STREAMING PAGE

1. Select Custom quality mode.
2. Select the desired resolution.
3. Select the desired frame rate.

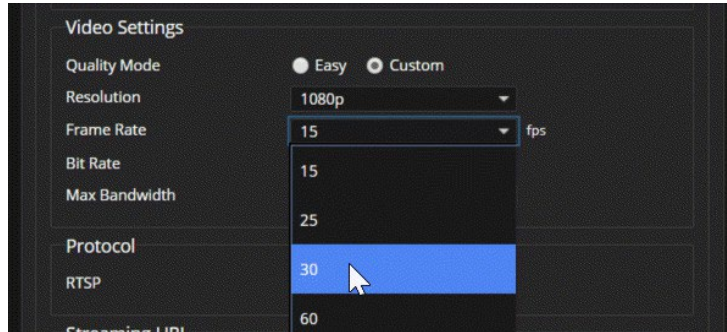

4. Select Constant or Variable bit rate.
5. Constant bit rate only: Set Max Bandwidth.

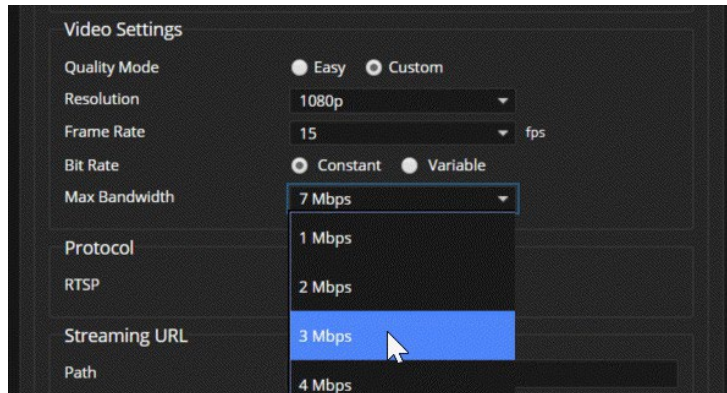

6. Variable bit rate only: Set the Quality (Quantization) slider.

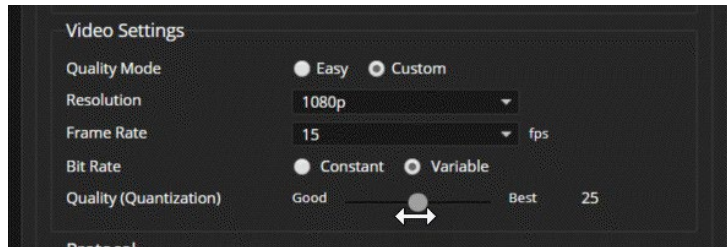

7. Save your changes.

RTSP Streaming Protocol and URL

STREAMING PAGE

RTSP is the default streaming protocol. When IP streaming is enabled, the RTSP stream is automatically available at the streaming URL shown.

RTSP port: Vaddio strongly recommends using the default RTSP port number.

Path: The portion of the streaming URL that appears after the IP address. You may wish to change this to help identify the stream source – for example, `demo-studio-3`.

URL: The location where the stream can be viewed. This will change if you edit the path.

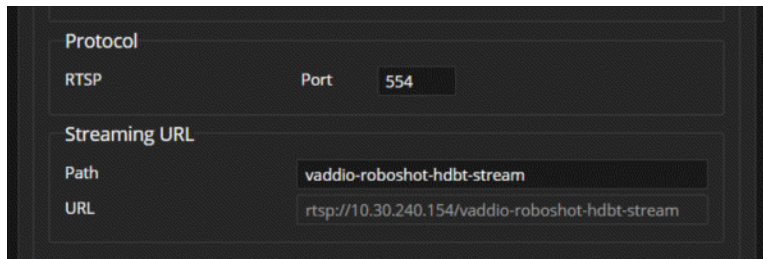

The image shows a configuration interface for RTSP streaming. It is divided into two main sections: 'Protocol' and 'Streaming URL'. In the 'Protocol' section, 'RTSP' is selected and the 'Port' is set to '554'. In the 'Streaming URL' section, the 'Path' is 'vaddio-roboshot-hdbt-stream' and the 'URL' is 'rtsp://10.30.240.154/vaddio-roboshot-hdbt-stream'.

Protocol	
RTSP	Port 554

Streaming URL	
Path	vaddio-roboshot-hdbt-stream
URL	rtsp://10.30.240.154/vaddio-roboshot-hdbt-stream

Your camera will present somewhat different information from this image, as the streaming URL incorporates the camera's model and IP address.

Configuring RTMP Streaming

STREAMING PAGE

To use RTMP streaming, you must have an account with a streaming service.

To configure an RTMP streaming service:

1. Select RTMP streaming, and select Settings.

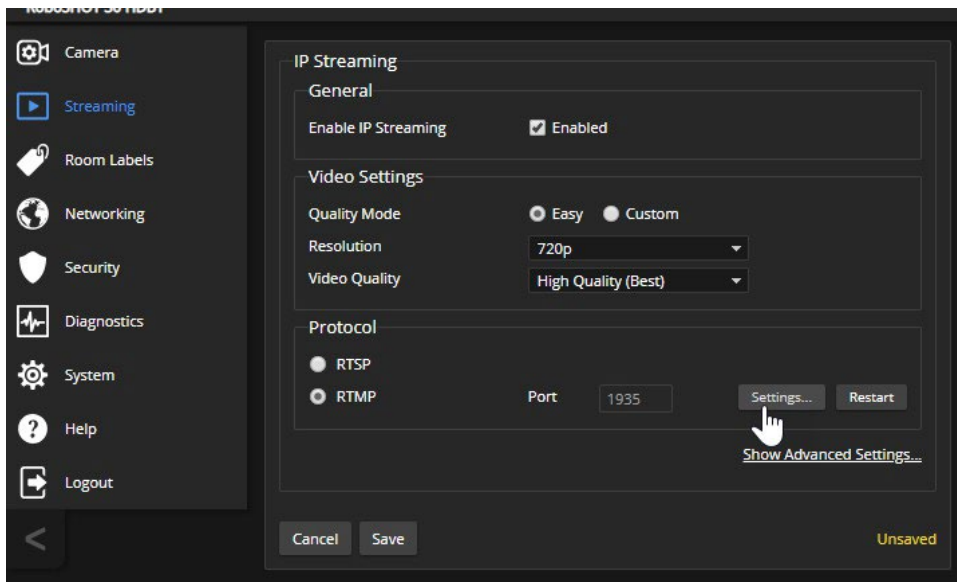

2. Expand the information box for the service.

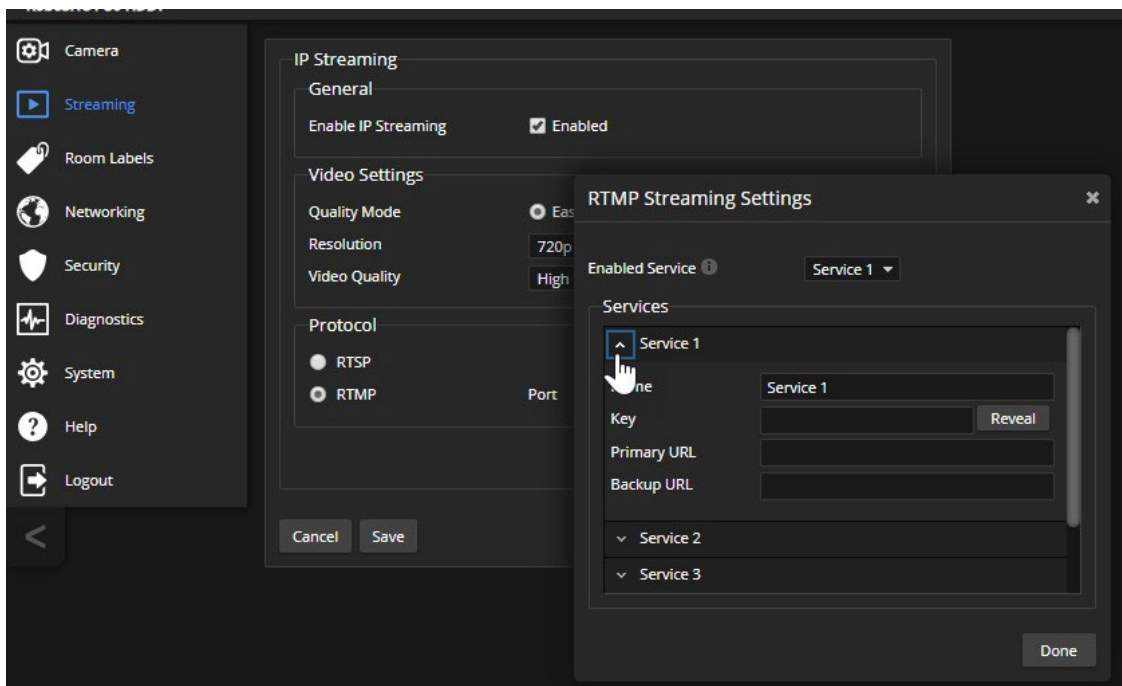

3. Enter the name of the service.
4. Paste in the key and URL(s) provided by the service.

To select the enabled RTMP streaming service:

Expand the list of available streaming services, and select the one to use.

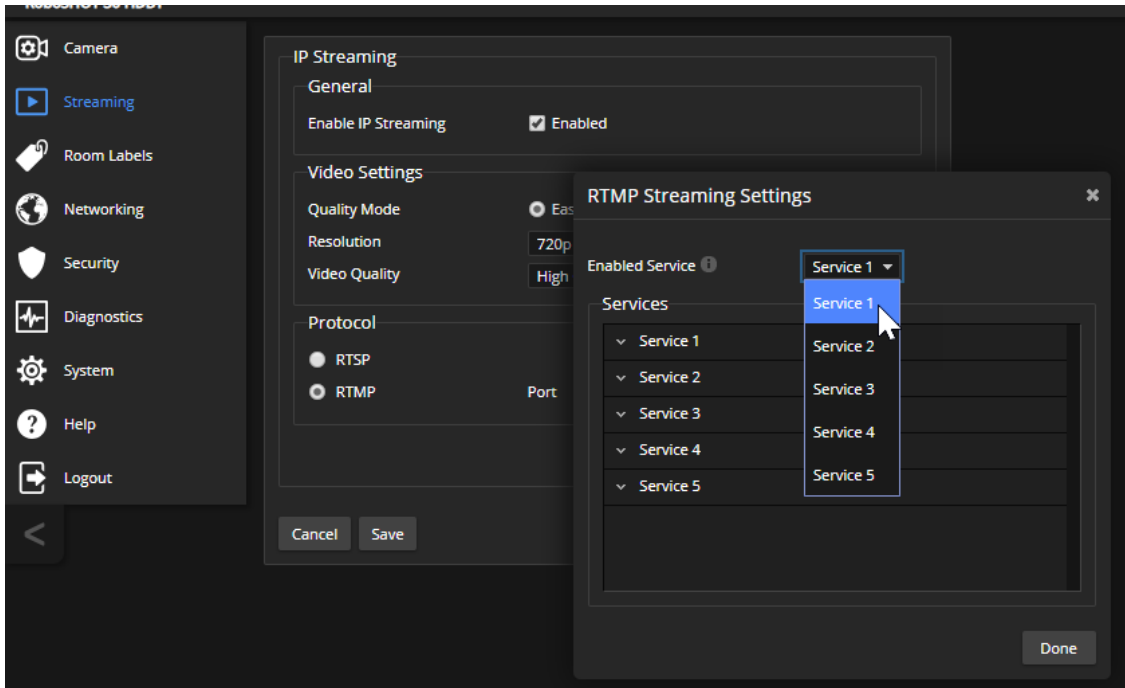

Note

When RTMP streaming is selected and a service is configured, the camera streams to that service until you stop the stream.

Setting the Custom Home Position and Other Preset Shots

CAMERA PAGE

The camera's default home position is 0° pan and 0° tilt, at 1x zoom; you can set a different home position. You can also define other presets for shots that you expect to use repeatedly.

Note

Storing a preset overwrites any information that was previously associated with that preset. The Store Preset dialog does not show which presets have already been defined. Vaddio recommends renaming presets when you store them.

To store a preset or custom home position:

1. Set up the shot. If necessary, adjust color and lighting (CCU settings) as well.
2. Select Store to open the Store Preset dialog.

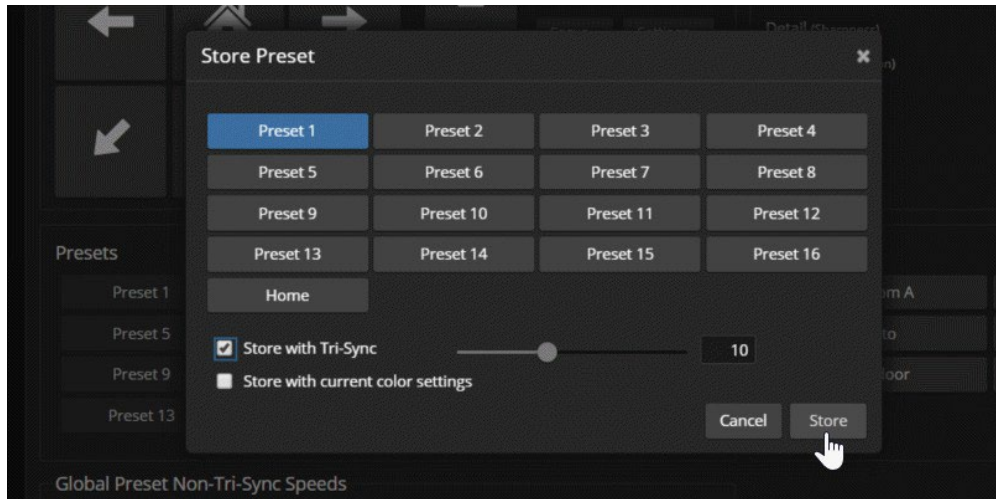

3. Select the preset to define.
4. Select Store with Current Color Settings to save the current CCU settings along with the camera position.
5. Select Save with Tri-Sync to allow the pan, tilt, and zoom motors to move simultaneously from other presets to this position.
6. Store the preset.

Notes

Tri-Synchronous Motion works best for on-air shots requiring significant movement. It is not useful when moving the camera less than 10° or when the camera is not on the air.

By default, the Home position stores with current color settings and Tri-Sync. Other presets do not.

Renaming Presets and Custom CCU Scenes

CAMERA PAGE

You can rename presets and custom scenes. The process is the same for both. Right-click the button for the custom scene or preset, and edit the label.



Working with Preset Chains

CAMERA PAGE

Preset chains automate the process of moving through a series of shots. If you know people will want to move the camera through the same set of shots routinely, program a preset chain.

Things to know about preset chains:

- Each chain can have up to 12 *waypoints*; each of these can be an existing preset or a shot that you set up as you create the chain.
- You can set the chain to run once, or to run as a continuous loop.
- Individual waypoints can be reordered or deleted.
- Custom waypoints can be recalled to view the shot, and changed as needed.
- Each waypoint allows you to specify a delay after movement.
- Preset chains may be set to run in a continuous loop, or just once.
- Preset chains can be stopped while running.

To define a preset chain:

1. In the Preset Chains area, select Edit. The Preset Chains window opens.

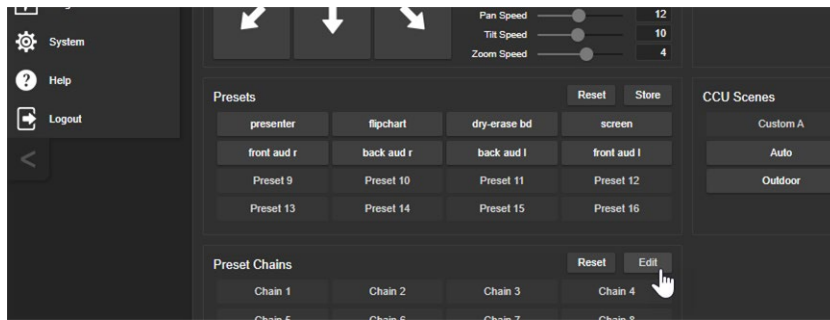

2. Select the chain to edit, if it is not already selected.
3. Select Add Waypoint. A waypoint definition box opens in the Waypoints area.

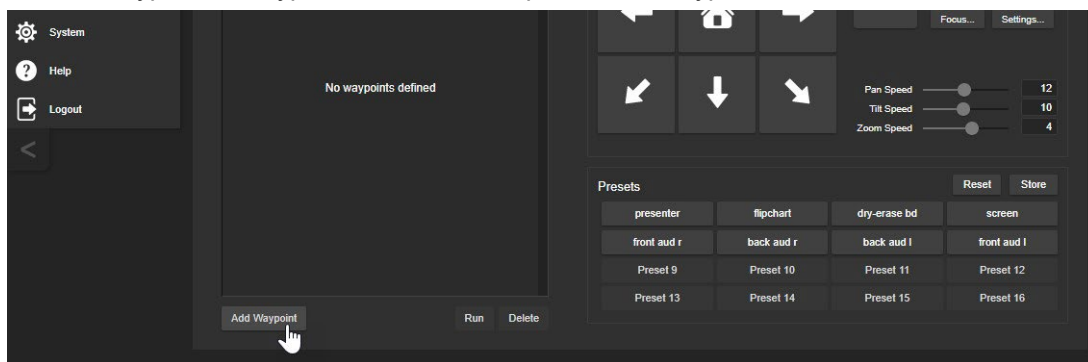

4. Do one of these things:
 - o Open the preset list and select from the available presets.
 - o Leave the definition as Custom Waypoint and use the camera controls to set up the shot you want, then store it as you would store a preset.
5. Repeat steps 3 and 4 until you have added all the desired waypoints.

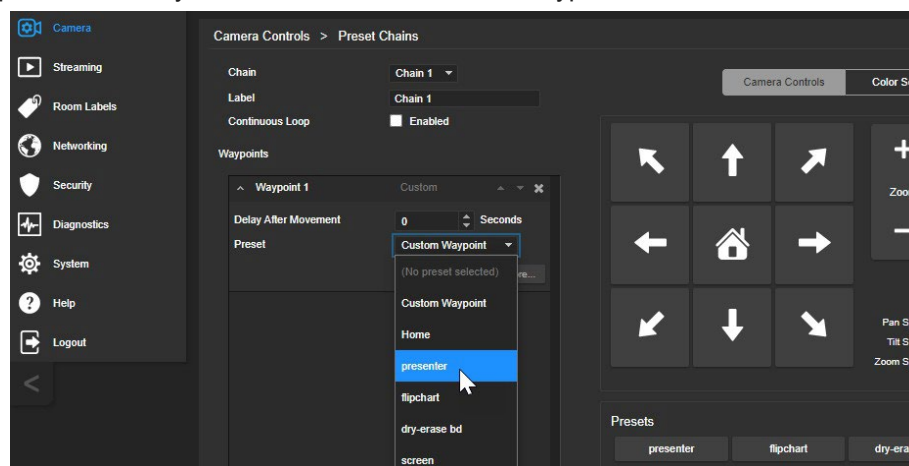

To run a preset chain:

From the main Camera page or the operator's page, select a preset chain.

To stop a preset chain:

From the main Camera page or with the remote, select any preset or other camera movement.

Initial Lighting and Color Settings

CAMERA PAGE

No two rooms are exactly alike – but a lot of rooms are a lot alike. The technical folks at Vaddio (Scott, to be specific) have already set up adjustments for common lighting scenarios (CCU scenes) – Incandescent Hi, Incandescent Lo, Fluorescent Hi, Fluorescent Lo, and Outdoor. The Auto setting allows the camera to determine the appropriate adjustments.

Adjust the camera for the lighting in use by selecting the CCU scene that best fits your environment.

Some adjustments to lighting and color may be necessary.

Note

Color adjustments are not available when the Auto scene is selected.

Lighting Adjustments

CAMERA PAGE

The camera provides settings to compensate for common lighting problems.

- **Auto Iris** allows the camera to compensate automatically for the light level.
- **Backlight Compensation** reduces contrast to adjust for bright light behind the main subject of the shot. Use this if the subject is in front of a window, projector screen, or other bright area and appears as a silhouette. This setting can't be used with Wide Dynamic Range.
- **Wide Dynamic Range** automatically darkens bright areas and brightens dark areas to provide a more properly exposed image in challenging lighting conditions. This setting can't be used with Backlight Compensation.

SYSTEM PAGE, GENERAL TAB

The [Lighting and Image Quality Cheat Sheet](#) may be helpful.

Fine-Tuning Image Quality and Color

CAMERA PAGE

Fine-tune the color and lighting as needed using the Color Settings controls.

- **Auto White Balance** adjusts color automatically. Red gain and blue gain controls are not available when Auto White Balance is selected.
- **Red Gain** and **Blue Gain** provide manual color adjustment.
- **Detail** adjusts the image sharpness. If the video looks grainy or “noisy,” try a lower Detail setting. (As in conversation, too much detail is bad.)
- **Chroma** adjusts the color intensity.
- **Gamma** adjusts the range (grey density) between bright areas and shadows.

If you change Red Gain or Blue Gain and you don't like the results, start over by selecting and then deselecting Auto White Balance.

The [Color Adjustment Cheat Sheet](#) may be helpful.



Lighting and Image Quality Cheat Sheet

Here are some tips for using the CCU settings for lighting and image quality. For more detailed information on each setting, see [Lighting Adjustments](#) and [Fine-Tuning Image Quality and Color](#).

What do you need to correct?	Make this adjustment:
The image is too dark	Increase Iris (lower F-stop value)
	Increase Iris Gain
The image looks washed out or faded	Decrease Iris (higher F-stop value)
	Decrease Iris Gain
	Increase Chroma
	Decrease Gamma
The subject is silhouetted against a bright background	Enable Backlight Compensation
Highlights and shadows look right, but mid-tones are too dark.	Increase Gamma
Shadows are too dark	Enable Wide Dynamic Range (WDR)
	Decrease Gamma
The image looks grainy	Decrease Detail
	Decrease Iris Gain
"Soft focus" effect; the image looks unrealistically smooth	Increase Detail

Color Adjustment Cheat Sheet

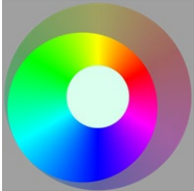
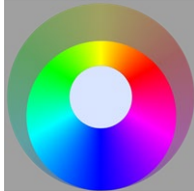
Here are some tips for using the color-related CCU settings. For more detailed information on each setting, see [Fine-Tuning Image Quality and Color](#).

What do you need to correct?	Make this adjustment:
Colors look less vivid than they should	Increase Chroma
Colors look too vivid	Decrease Chroma
Colors look wrong; white objects do not appear white	Enable Auto White Balance
	One Push White Balance
	Disable Auto White Balance and <ul style="list-style-type: none"> ■ adjust Red Gain (decrease for less red, increase for less green) ■ adjust Blue Gain (decrease for less blue, increase for less yellow)
<div style="display: flex; justify-content: space-around; text-align: center;"> <div>Too much red </div> <div>Not enough red </div> <div>Too much blue </div> <div>Not enough blue </div> <div>Balanced </div> </div>	

Saving Color and Lighting Settings

CAMERA PAGE

If you are adjusting for lighting conditions that are likely to recur, you can save your adjustments as a custom scene.

1. Adjust lighting, image quality, and color.
2. When the scene looks the way you want it to, click Store CCU Scene.
3. In the Store CCU Scene dialog box, select which custom scene to store (Custom A, B, or C) and select Save.

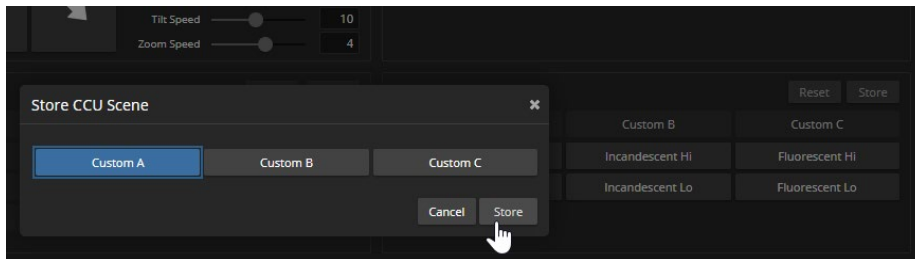

4. Optional: Name the new scene by right-clicking its button. A dialog box opens. Enter the name and save it.

Speed Adjustments

CAMERA PAGE

The following speed adjustments are available:

- Manual pan, tilt, and zoom speeds – Used when you control camera movements with the IR Remote Commander or the arrow buttons in the web interface
- Global Preset Non-Tri-Sync Speeds – Separate pan, tilt, and zoom speeds used for movements between presets that do not use Tri-Synchronous Motion.
- Tri-Synchronous Motion speed – Only available when storing a preset with the Store with Tri-Sync option selected.

About Tri-Synchronous Motion

The Tri-Synchronous Motion algorithm calculates the pan, tilt and zoom speeds needed for the camera to move to a preset position, so that all three movements begin together and arrive at the same time. It ensures smooth on-air movements when making large changes in position, particularly when the zoom also changes. Tri-Synchronous Motion is only available as an option for moving to specific preset position.

Tri-Synchronous Motion is not helpful in movements of less than 10°, and is typically used only for on-air operation.

Setting the Speed for Manual Movements

CAMERA PAGE

The Pan Speed, Tilt Speed, and Zoom Speed sliders control how fast the camera moves in response to the direction and zoom controls on the IR remote and in the web interface.

To set speeds for movements using the arrow buttons:

Use the speed sliders to adjust the speed of movements that you control with the buttons for pan, tilt, and zoom. For tight shots, slower is usually better.

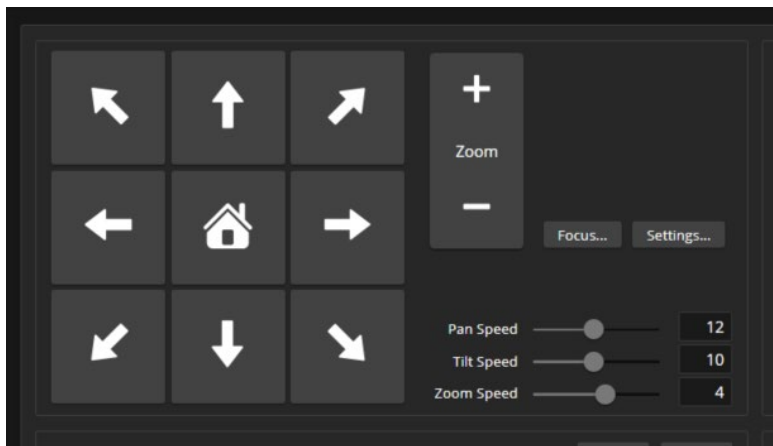

Setting the Speed of Movements to Presets

CAMERA PAGE

To set speeds for movements to presets:

1. Store presets at several points in the room, at different zoom levels, saving them without selecting the Tri-Sync option.
2. Move among the presets using the preset buttons.
3. Use the Global Preset Non-Tri-Sync Speed sliders to adjust as needed.

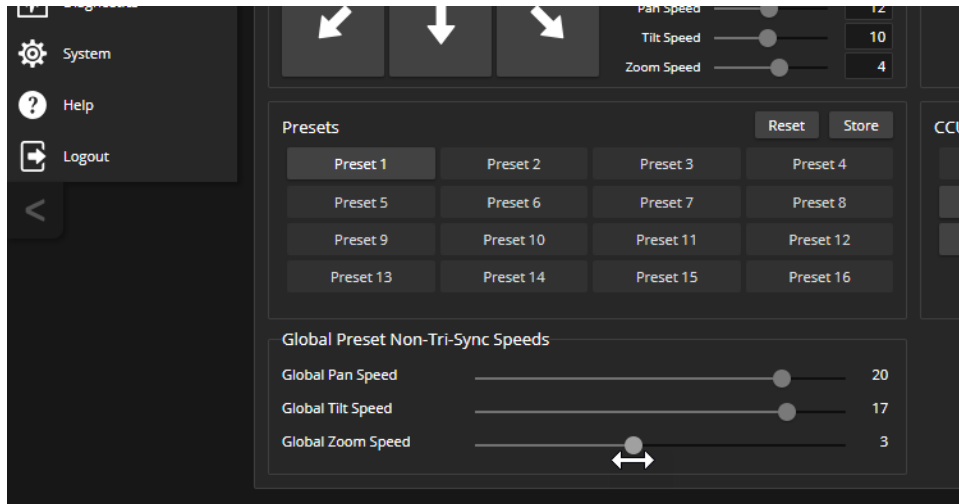

Adjusting Tri-Synchronous Motion Speed

CAMERA PAGE

The Tri-Synchronous Motion algorithm calculates the pan, tilt and zoom speeds needed for the camera to move from one preset to the next so that all three movements begin together and arrive at the same time. You may need to experiment to find the best Tri-Sync speed setting. Here is a simple method:

1. Store a preset, checking Save with Tri-Sync and setting the speed slider about a third of the way along the scale.
2. Move the camera to a different pan, tilt, and zoom position, and save this position as another preset. Again, check Save with Tri-Sync; but set the speed slider to about the halfway point.
3. Move the camera from one preset to the other to evaluate which movement is closer to the speed you want. Use the Tri-Sync speed associated with that preset, or adjust it as needed.
4. Store all the presets you will need.
5. Switch among the presets to determine whether any of them should use different Tri-Sync speeds.
6. Adjust the speeds as needed.

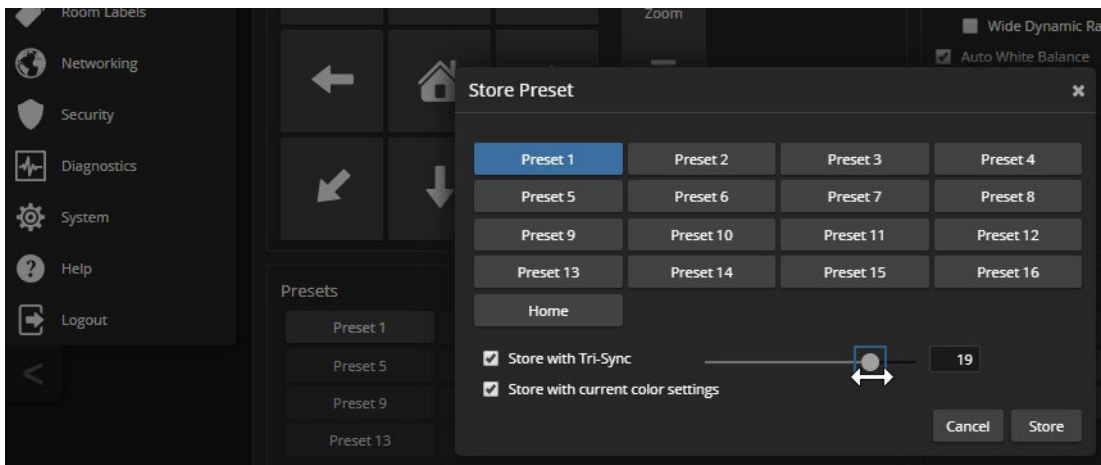

Setting the Direction for Camera Movements

CAMERA PAGE

By default, the arrow buttons on the remote and in the web interface show the direction you would see the camera move if you were looking the same direction as the camera. If a person facing the camera is controlling it with the remote, using the right arrow pans the camera to the person's left.

To make the arrow buttons indicate camera movement from the perspective of a person facing the camera, open the Settings control and invert the pan direction.

Note

Tilt direction is automatically inverted when you select Image Flip for inverted mounting. You do not need to set tilt direction with the motor controls.

Additional Settings

SYSTEM PAGE, GENERAL TAB

The General tab of the System page provides access to:

- Status light behaviors
- Video behaviors
- Interactions with the IR remote
- Serial communication options

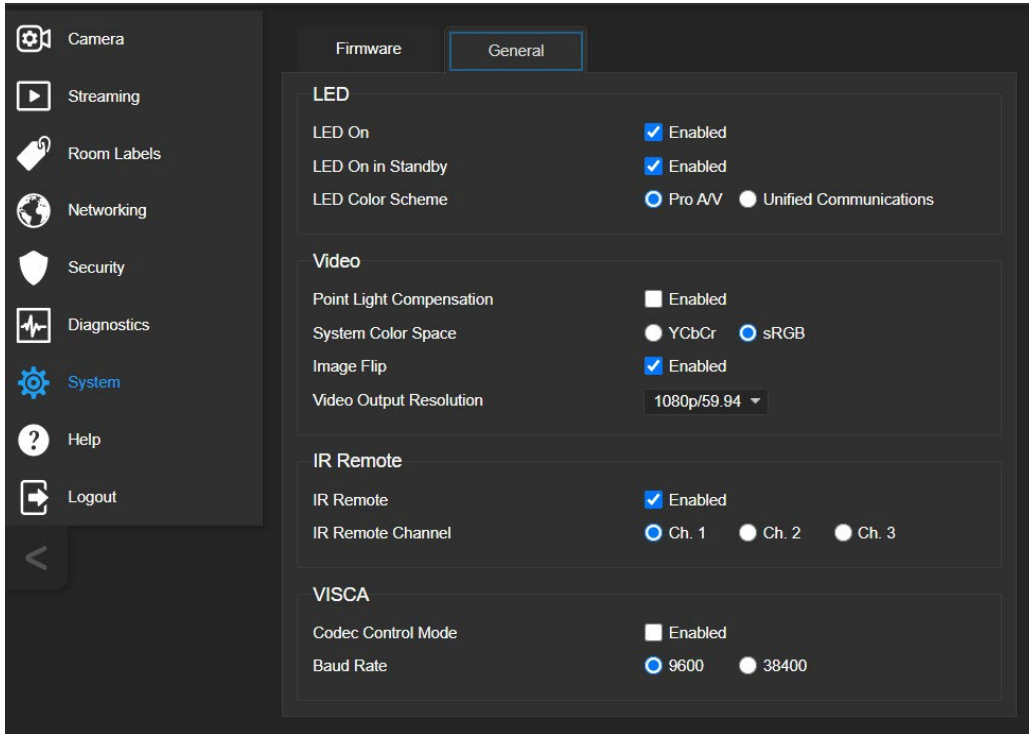

Setting Name	Function
LED On/Off	The status light can be turned off. The
LED On in Standby	Select Disabled to turn off the LED when the camera is in standby mode.
LED Color Scheme	Status light color codes for Pro AV (broadcast) or UC (unified conferencing). Default is Pro A/V.
Point Light Compensation	Reduces the intensity of small, extremely bright areas (point light sources) that would otherwise swamp the camera with light and make it difficult to see details in areas with less intense lighting.
System Color Space	YCbCr or sRGB. The default is sRGB.
Image Flip	On by default; orients the video image correctly and sets the tilt motors to respond appropriately to tilt commands from the remote, web interface, and connected control devices.

Setting Name	Function
Video Output Resolution	Select the desired video output resolution and frame rate. Default is 1080p/59.94.
IR Remote	Enable/disable the camera's IR sensor. Leave this ON if using the IR Remote Commander to control the camera.
IR Remote Channel	The IR Remote Commander can control up to three cameras in the same room with different IR frequencies. Select the channel this camera uses; then use the Camera Select buttons at the top of the remote to select the camera you want to control.
Codec Control Mode	Select Codec Control Mode if using the camera with a third-party codec.
Baud Rate	RS-232 serial communication rate; 9600 bps is default. Must match the baud rate of the device connected to the RS-232 port.

The Image Flip setting is on by default for the RoboFLIP 4K HDBT camera.

System Maintenance

This chapter covers maintenance tasks.

What's in this chapter:

- Saving and restoring the camera's configuration data
- Updating firmware
- Rebooting

The System pages for the different products are similar to each other, but include product-specific features as well.

Saving (Exporting) or Restoring (Importing) a Camera Configuration

SYSTEM PAGE, FIRMWARE TAB

You can import a configuration to several cameras if you need to configure them the same way. Cameras must be of the same model, and must have a compatible firmware version installed. Configuration data does not include passwords or unique information such as hostname.

1. Configure the first camera.
2. Export its configuration (Export Data button). The export downloads to your computer as a `.dat` file. The filename is the camera's hostname.

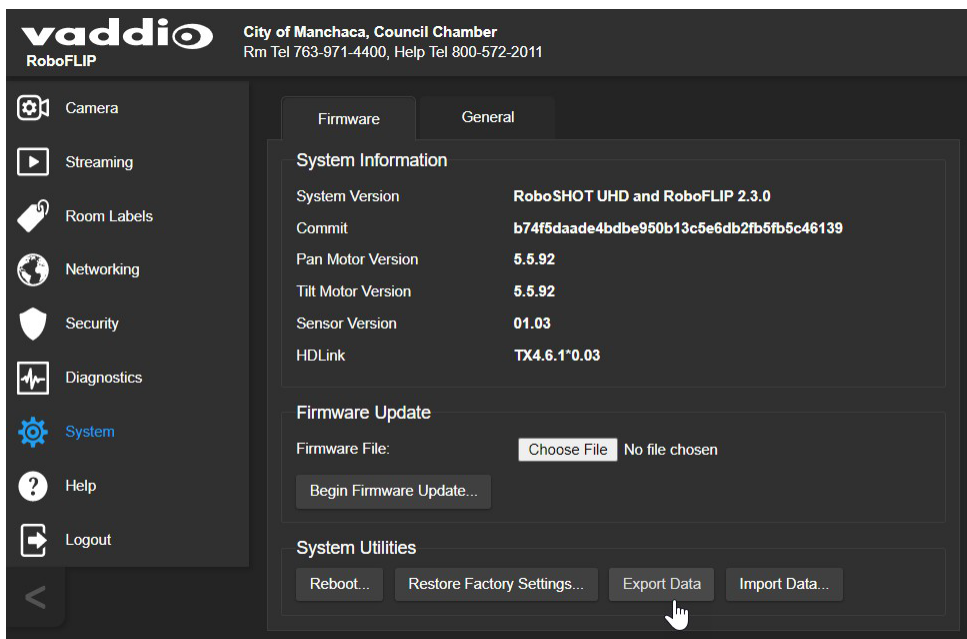

3. Import the configuration to the other cameras (Import Data button in each camera's web interface). The web interface prompts you to browse to the `.dat` file that will be imported.

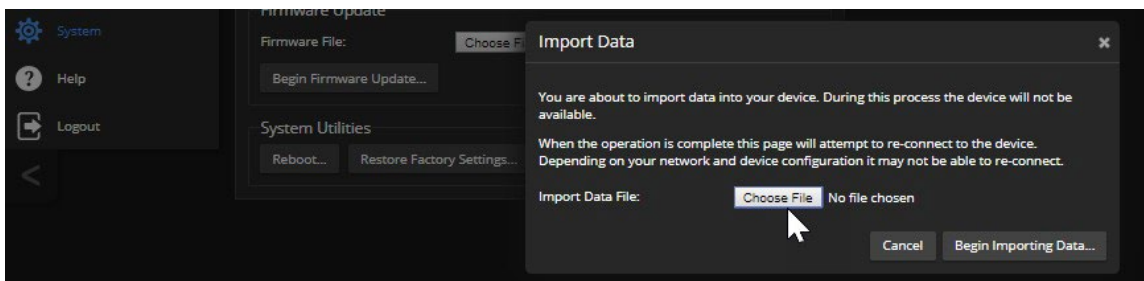

Installing a Camera Firmware Update

SYSTEM PAGE, FIRMWARE TAB

Caution

The camera must remain connected to power and to the network during the update. Interrupting the update could make the camera unusable.

1. Download the firmware and its release notes.
2. Select Choose File, then browse to the downloaded firmware and select it. The filename ends with .p7m.
3. Select Begin Firmware Update.
4. Read and understand the information in the Confirm dialog box. It's dull, but it could save you some time and aggravation.
5. Select Continue. A progress message box opens and the status light on the front of the camera turns yellow. If the update process presents warnings or error messages, read them carefully.

The camera reboots when the update is complete.

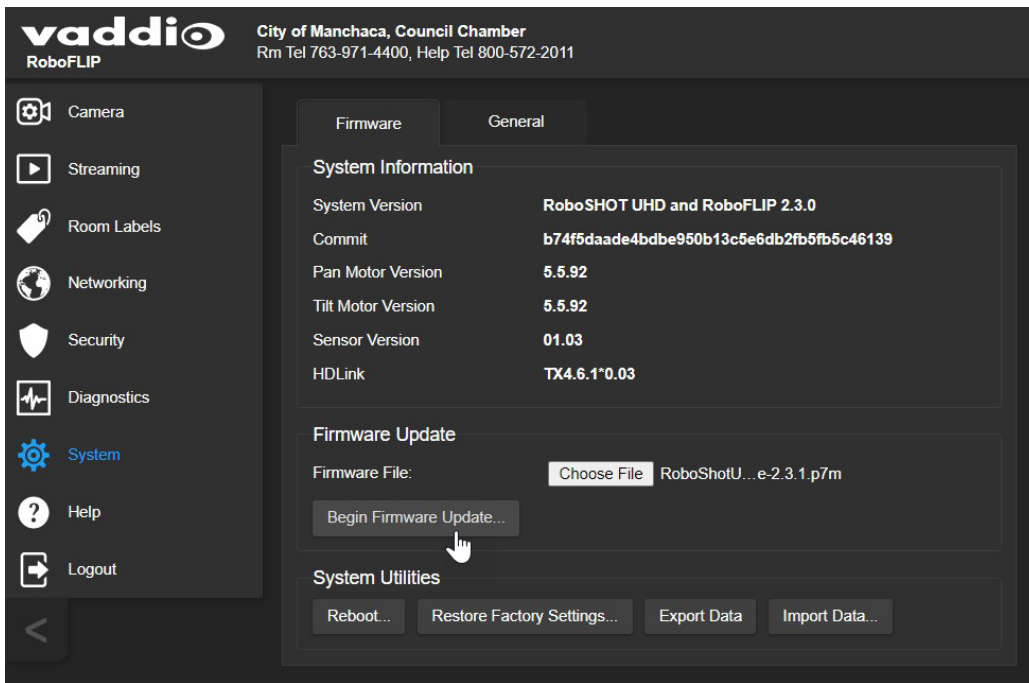

Rebooting the Camera

SYSTEM PAGE, FIRMWARE TAB

This can help if the camera stops responding as you expect.

In the System Utilities section, select Reboot.

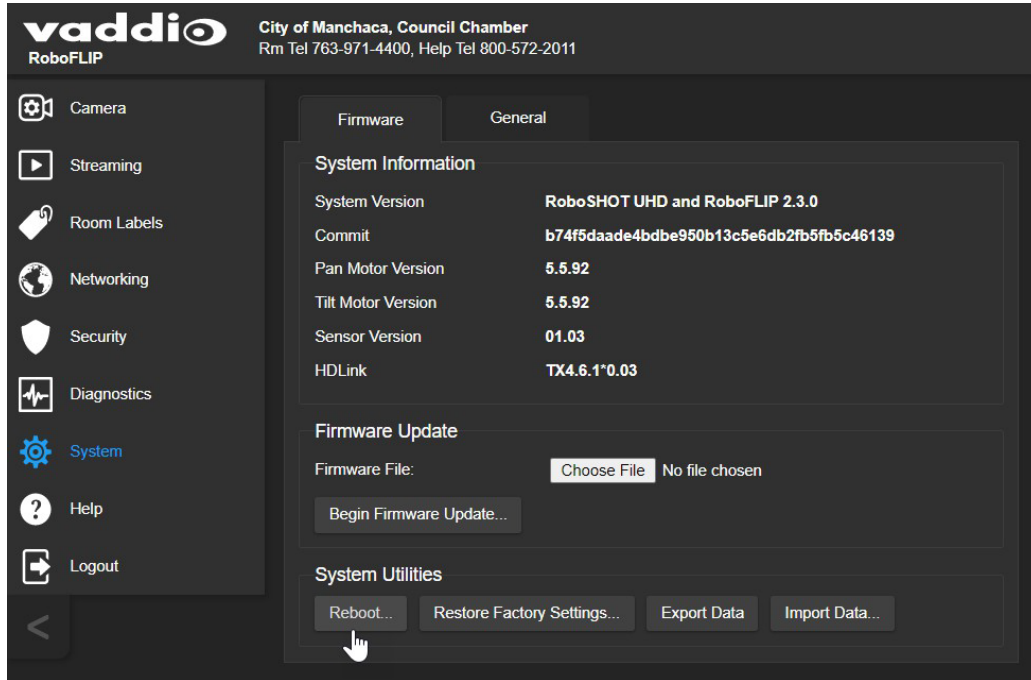

Contacting Vaddio Technical Support

HELP PAGE

If you can't resolve an issue using your troubleshooting skills (or the [Troubleshooting](#) table in this manual), we are here to help.

You'll find information for contacting Vaddio Technical Support on the Help page. The model identifier and the link for support information vary depending on the camera model.

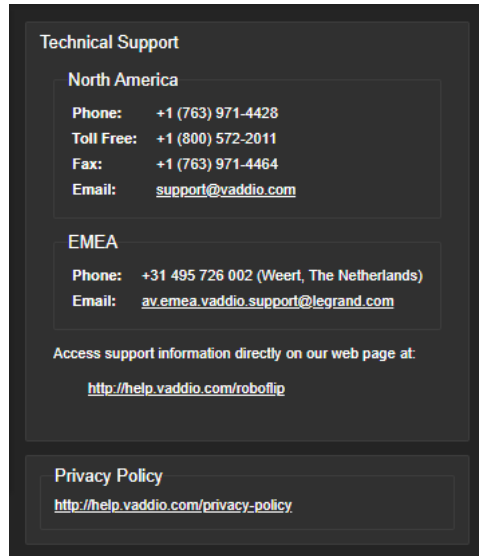

Technical Support

North America

Phone: +1 (763) 971-4428
Toll Free: +1 (800) 572-2011
Fax: +1 (763) 971-4464
Email: support@vaddio.com

EMEA

Phone: +31 495 726 002 (Weert, The Netherlands)
Email: av.emea.vaddio.support@legrand.com

Access support information directly on our web page at:
<http://help.vaddio.com/roboflip>

Privacy Policy
<http://help.vaddio.com/privacy-policy>

Note

The Help page provides a link to our standard privacy notice. This product does not record or save video files, and it does not store any identifying information other than what you may choose to enter on the Room Labels page of the web interface. However, the camera's IP address is considered "personally identifiable information" for the purposes of the privacy notice. This information is stored for display to the user, but not otherwise shared or transmitted.

Accessing the Diagnostic Logs

DIAGNOSTICS PAGE

If you encounter a problem that you can't solve, your Vaddio technical support representative may ask you to download and email the log file available from the Diagnostics screen.

Note

The log may include large numbers of internal events even when no errors have occurred. Rebooting generates over 100 log entries.

vaddio City of Manchaca, Council Chamber
RoboFLIP Rm Tel 763-971-4400, Help Tel 800-572-2011

Diagnostics

```

Nov 6 03:33:24 vaddio-roboflip-04-91-62-08-26-EE kernel: [ 1.015603] aze_h264s 60000000.h264_axis_core: h264: added driver successfully
Nov 6 03:33:24 vaddio-roboflip-04-91-62-08-26-EE kernel: [ 1.024364] sdhci: Secure Digital Host Controller Interface driver
Nov 6 03:33:24 vaddio-roboflip-04-91-62-08-26-EE kernel: [ 1.031125] sdhci: Copyright(c) Pierre Ossman
Nov 6 03:33:24 vaddio-roboflip-04-91-62-08-26-EE kernel: [ 1.035473] sdhci-pltfm: SDHCI platform and OF driver helper
Nov 6 03:33:24 vaddio-roboflip-04-91-62-08-26-EE kernel: [ 1.067156] mmc0: SDHCI controller on e0100000.mmc [e0100000.mmc] using ADMA
Nov 6 03:33:24 vaddio-roboflip-04-91-62-08-26-EE kernel: [ 1.076286] ledtrig-cpu: registered to indicate activity on CPUs
Nov 6 03:33:24 vaddio-roboflip-04-91-62-08-26-EE kernel: [ 1.087755] Initializing XFRM netlink socket
Nov 6 03:33:24 vaddio-roboflip-04-91-62-08-26-EE kernel: [ 1.092143] NET: Registered protocol family 17
Nov 6 03:33:24 vaddio-roboflip-04-91-62-08-26-EE kernel: [ 1.096530] 8021q: 802.1Q VLAN Support v1.8
Nov 6 03:33:24 vaddio-roboflip-04-91-62-08-26-EE kernel: [ 1.101105] Registering SWP/SWPB emulation handler
Nov 6 03:33:24 vaddio-roboflip-04-91-62-08-26-EE kernel: [ 1.116690] ALSA device list:
Nov 6 03:33:24 vaddio-roboflip-04-91-62-08-26-EE kernel: [ 1.119817] #0: xylon-logi12s 0
Nov 6 03:33:24 vaddio-roboflip-04-91-62-08-26-EE kernel: [ 1.128125] Freeing unused kernel memory: 4096K
Nov 6 03:33:24 vaddio-roboflip-04-91-62-08-26-EE kernel: [ 1.133016] Run /init as init process
Nov 6 03:33:24 vaddio-roboflip-04-91-62-08-26-EE kernel: [ 1.138758] mmc0: new high speed SD card at address b368
Nov 6 03:33:24 vaddio-roboflip-04-91-62-08-26-EE kernel: [ 1.148410] mmcblk0: mmc0:b368 AF UD 471 MiB
Nov 6 03:33:24 vaddio-roboflip-04-91-62-08-26-EE kernel: [ 1.177671] mmcblk0: p1 p2 p3 p4 < p5 p6 p7 p8 >
Nov 6 03:33:24 vaddio-roboflip-04-91-62-08-26-EE kernel: [ 1.511995] random: fast init done
Nov 6 03:33:24 vaddio-roboflip-04-91-62-08-26-EE kernel: [ 4.009200] random: dd: uninitialized urandom read (512 bytes read)
Nov 6 03:33:24 vaddio-roboflip-04-91-62-08-26-EE kernel: [ 5.513544] random: dbus-uuidgen: uninitialized urandom read (12 bytes read)
Nov 6 03:33:24 vaddio-roboflip-04-91-62-08-26-EE kernel: [ 5.520741] random: dbus-uuidgen: uninitialized urandom read (8 bytes read)
Nov 6 03:33:24 vaddio-roboflip-04-91-62-08-26-EE kernel: [ 5.556598] random: dbus-daemon: uninitialized urandom read (12 bytes read)
Nov 6 03:33:24 vaddio-roboflip-04-91-62-08-26-EE kernel: [ 10.730317] random: crng init done
Nov 6 03:33:24 vaddio-roboflip-04-91-62-08-26-EE kernel: [ 10.733718] random: 2 urandom warning(s) missed due to ratelimiting
Nov 6 03:33:30 vaddio-roboflip-04-91-62-08-26-EE watchdog[903]: starting daemon (5.15):
Nov 6 03:33:34 vaddio-roboflip-04-91-62-08-26-EE kernel: [ 21.000370] rc rc0: two consecutive events of type space
Nov 6 03:33:36 vaddio-roboflip-04-91-62-08-26-EE kernel: [ 22.550537] macb e0000000.ethernet eth0: link up (100/Full)
Nov 6 03:34:01 vaddio-roboflip-04-91-62-08-26-EE root: Rotating /var/log/boot to /media/vng-logs/
    
```

Download Refresh Clear Restore Auto-Refresh

Using the IR Remote

The IR remote provides basic camera control.

What do you need to do?	Button(s)	
Power on or standby	Power (green button at top right)	
Select the camera to control (if this remote controls more than one)	Camera Select buttons 1 through 3 (second row of buttons)	
Discover the camera's IP address	Data Screen button (top left) overlays IP and MAC addresses on video output. Press again to dismiss.	
Move the camera	Arrow buttons and Home button (dark red)	
Make left and right arrows behave intuitively	Std Pan directions are from the camera's point of view, Rev Pan reverses this.	
Move the camera to a preset position	Position Preset buttons 1 through 6 (bottom two rows)	
Store a preset	Preset button + a numbered Position Preset button	
Clear a preset	Reset button + a numbered Position Preset button	
Adjust for excess light behind the camera's subject	Back Light button (top center)	
Focus the camera	Auto Focus button (near arrow buttons) Manual Focus buttons Near and Far (below Zoom Speed buttons)	
Zoom in (tele) or out (wide)	Zoom Speed buttons (light gray) - Slow T and W , Fast T and W for telephoto (zoom in) and wide-angle (zoom out) modes	

For information about configuring the camera to respond to the remote as camera 1, 2, or 3, see [Additional Settings](#).

Storing a Preset Using the Remote

Position the camera. Then hold down the Preset button and press one of the numbered preset buttons.

Clearing a Preset Using the Remote

Press and hold the Reset button while pressing the preset number you want to clear.

Operating the Camera from the Web Interface

CONTROLS PAGE

By default, the operator's page of the web interface is not available. The administrator must set a password for the `user` account or enable guest access.

Only the operator's page is available with user or guest access.

The web interface is available on the Vaddio Device Controller (if your installation uses one) or from a computer's web browser.

The Controls page provides most of the same controls as the IR Remote Commander. See [Using the IR Remote](#).

- Stop or resume sending live camera video (video mute)
- Move to camera presets, if any have been stored
- Pan, tilt, zoom, or return it to its home position
- Put the camera in standby or bring it back to the ready state
- Select a custom lighting adjustment, if any have been stored

If your installation does not include a Vaddio Device Controller or other control surface, contact the system administrator to find out how to access the web interface.

Switching the Camera Off or On (Standby)

Use the Standby button to switch between low-power (standby) and ready states. On entering standby mode, the camera moves to its standby position and stops sending video.

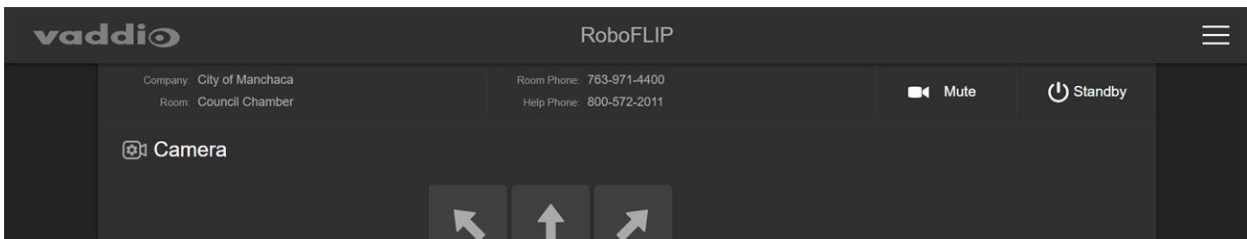

Stop or Resume Sending Video (Mute)

Use the Mute button to stop sending live video without putting the camera in standby mode. When the video is muted, the camera sends a blue or black screen. If the camera is part of a conferencing system, this does not mute the audio.

Moving the Camera

Use the arrow buttons for camera pan and tilt. The center button moves the camera to the home position.

Zooming In or Out

Use the Zoom + button to zoom in and the Zoom - button to zoom out.



Moving the Camera to a Preset Position

Presets are camera shots that have been stored. They include pan, tilt, and zoom information, and may include color and speed information as well. If no presets are defined, the Controls page does not present the Presets section.

Use the Preset buttons to move the camera to any of its preset positions.

Adjusting the Color and Lighting

If any color and lighting adjustments (CCU scenes) have been saved, they are available in the Scenes area, along with the Auto setting. In most cases, the Auto setting is appropriate. This setting allows the camera to adjust to current conditions automatically.

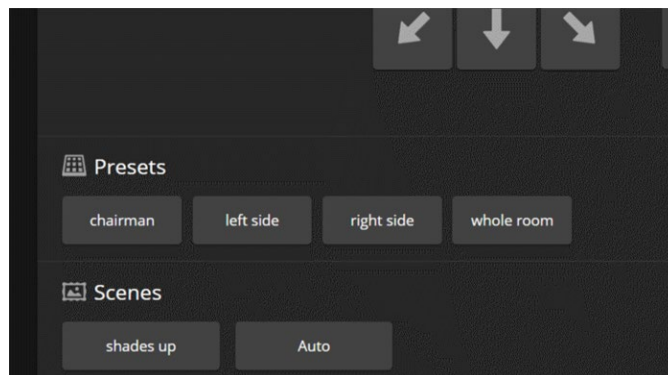

Telnet Command Reference

Vaddio's Telnet command protocol allows external devices to control the camera. Network connectivity and a Telnet client are required; Telnet port 23 is used. Telnet sessions require the administrator account login.

In addition to the camera control commands, Telnet session management commands are available – help, history, and exit.

Things to know about Telnet:

- By default, Telnet access is disabled in all firmware releases issued after mid-December 2019. Enable it on the Security page of the web interface.
- The > character is the command prompt.
- Using a question mark as a command parameter will bring up a list of available subcommands or parameters. Example:

```
camera focus ?
camera focus
near    Focus the camera near
far     Focus the camera far
stop    Stop the camera focus
mode    Camera focus mode
```

- CTRL-5 clears the current serial buffer on the device.

Typographical conventions used in this manual:

- { **x** | **y** | **z** } – Choose x, y, or z. Example: camera led { on | off | toggle }
- <**variable**> – Substitute the desired value here. Example: camera ccu get <param>
- < **x - y** > – Valid range of values is from x through y. Example: camera ccu set detail <0 -15>
- [**parameter**] – Parameter is not required. Example: camera pan left [-speed>]

Note

Most of these commands are common to all Vaddio cameras. Some of the examples may not reflect the camera you have.

Camera and Video Management Commands

The following camera and video management commands are available:

- camera home
- camera pan
- camera tilt
- camera zoom
- camera ptz-position
- camera focus
- camera preset
- camera chained-preset
- camera ccu get
- camera ccu set
- camera led
- camera icr
- video mute
- camera standby

```
Telnet 192.168.1.66
BoardroomCamControl login: admin
Password:
Last login: Wed Mar 30 13:19:52 -0500 2016 on /dev/pts/0.
*****
Vaddio Interactive Shell
*****
WARNING: Authorized Access Only
*****

Welcome admin
> version
Serial 25120ceaf446a889cf282702a214efba0e6eb0c3
System Version PCC Premier 1.1.0-RC3
OK

> network settings get
Name eth0:MAN
MAC Address 00:1E:C0:8D:89:58
IP Address 192.168.1.66
Netmask 255.255.255.0
VLAN Disabled
Gateway 192.168.1.254
OK
>
```

camera home

Moves the camera to its home position.

Synopsis	camera home
Example	>camera home OK >

camera pan

Moves the camera horizontally.

Synopsis	camera pan { left [<speed>] right [<speed>] stop get set }	
Options	left	Moves the camera left.
	right	Moves the camera right.
	speed <1 – 24>	Optional: Specifies the pan speed as an integer (1 to 24). Default speed is 12.
	stop	Stops the camera's horizontal movement.
	set <position>	Sets the camera's absolute pan position in degrees, as a floating point value. Range is approximately -155.00 (left) and 155.00 (right). Individual cameras may have an additional degree or two of travel before they reach their physical limits. If the value is out of range, the camera returns an error message and no motion occurs. The speed parameter may be used with the camera pan set command. The camera pan set command blocks execution of subsequent commands until the camera reaches the specified position.
	get	Returns the camera's absolute pan position in degrees, as a floating point value.
Examples	<pre>>camera pan left OK ></pre> <p>Pans the camera left at the default speed.</p> <pre>>camera pan stop OK ></pre> <p>Stops the camera's horizontal motion.</p> <pre>>camera pan set -15 22 OK ></pre> <p>Pans the camera to 15° left of its centerline using a speed of 22.</p>	

camera tilt

Moves the camera vertically.

Synopsis	<code>camera tilt{ up [<speed>] down [<speed>] stop get set}</code>	
Options	<code>up</code>	Moves the camera up.
	<code>down</code>	Moves the camera down.
	<code>speed <1 – 20></code>	Optional: Specifies the tilt speed as an integer (1 to 20). Default speed is 10.
	<code>stop</code>	Stops the camera's vertical movement.
	<code>set <position></code>	<p>Sets the camera's absolute tilt position in degrees, as a floating point value between approximately -95.00 and 0.00.</p> <p>If the value is out of range, the camera returns an error message and no motion occurs. The speed parameter may be used with the <code>camera tilt set</code> command.</p> <p>The <code>camera tilt set</code> command blocks execution of subsequent commands until the camera reaches the specified position.</p>
	<code>get</code>	Returns the camera's absolute tilt position in degrees, as a floating point value.
Examples	<pre>>camera tilt up OK > Tilts the camera up at the default speed. >camera tilt stop OK > Stops the camera's vertical motion. >camera tilt set -5 5 OK > Tilts the camera 5° down from level at a speed of 5.</pre>	

camera zoom

Zooms the camera in toward the subject or out away from the subject.

Synopsis	camera zoom { in [<speed>] out [<speed>] stop get set}	
Options	in	Moves the camera in.
	out	Moves the camera out.
	speed [1 – 7]	Optional: Specifies the zoom speed as an integer (1 to 7). Default speed is 3.
	stop	Stops the camera's zoom movement.
	get	Returns the camera's current zoom level as a floating point value.
	set <1 – n>	<p>Sets the zoom level as a floating point value from 1.00 to 30.00.</p> <p>If the value is out of range, the camera returns an error message and no zoom change occurs. The speed parameter may be used with the <code>camera zoom set</code> command.</p> <p>The <code>camera zoom set</code> command blocks execution of subsequent commands until the camera reaches the specified position. Use the <code>no_wait</code> parameter if this is not the desired behavior.</p>
Examples	<pre>>camera zoom in OK > Zooms the camera in at the default speed. >camera zoom stop OK > Stops the camera's zoom motion. >camera zoom set 8 3 OK > Sets the camera's zoom level to 8x at a speed of 3. >camera zoom get 8 OK > Returns the camera's current zoom level.</pre>	

camera ptz-position

Specifies multiple-axis movements to absolute positions.

Pan, tilt, and zoom may be specified in any order. All movements start simultaneously.

Synopsis	camera ptz-position pan <position> tilt <position> zoom <position> [no_wait]	
Options	pan <position>	<position> is a floating-point value approximately -155.00 to 155.00. Individual cameras may have slightly more travel.
	tilt <position>	<position> is a floating-point value approximately -95.0 to 0. Individual cameras may have slightly more travel.
	zoom <position>	<position> is a floating-point value 1.0 to 30.0.
	no_wait	Optional – allows the command to return the command prompt immediately, while the requested camera movement is still in progress.
Examples	<pre>>camera ptz-position pan -15 tilt -5 zoom 1.5 no_wait OK ></pre> <p>Moves the camera 15° left from its centerline and 5° down from horizontal, and zooms to 1.5. The command prompt appears while the camera is still in motion.</p>	

camera preset

Moves the camera to the specified preset, or stores the current camera position and optionally CCU information, either with or without specifying that Tri-Synchronous Motion is to be used when moving to this position.

Note

This command corresponds to the CAM_Memory commands in the RS-232 command set.

Synopsis	camera preset { recall store } <1 – 16> [tri-sync <1 – 24>] [save-ccu]	
Options	recall <1 – 16>	Moves the camera to the specified preset, using Tri-Synchronous Motion if this was saved with the preset. If CCU information was saved with the preset, the camera switches to the CCU setting associated with the preset.
	store <1 – 16>	Stores the current camera position as the specified preset.
	tri-sync <1 – 24>	Optional: Specifies that the camera uses Tri-Synchronous Motion to move to this position, using the specified speed.
	save-ccu	Optional: Saves the current CCU settings as part of the preset. If not specified, the last color settings are used when recalled.
Examples	<pre>>camera preset recall 3 OK > Moves the camera to preset 3. >camera preset store 1 OK > Saves the camera's current position as preset 1. >camera preset store 4 tri-sync 15 OK > Stores the camera's current position as preset 4. The camera will use Tri-Synchronous Motion at speed 15 when it is recalled to this preset. >camera preset store 2 save-ccu OK > Stores the camera's current position as preset 2. The camera applies the current CCU settings when it is recalled to this preset.</pre>	

camera chained-preset

Starts or stops a preset chain that has been defined in the web interface.

Synopsis	camera chained-preset { recall <chain> stop }	
Options	recall <1 – 16>	Runs the specified preset chain. If the chain is not defined, the command returns an error.
	stop	Stops the camera's movement.
Examples	<pre>>camera chained-preset recall 3 OK > Starts preset chain 3. >camera chained-preset stop OK > Stops the preset chain currently in progress.</pre>	

camera ccu scene

Stores the current CCU scene or recalls the specified ccu scene.

Synopsis	camera ccu scene {recall {factory <1 – 6> custom <1 – 3>} store custom <1 – 3>}	
Options	recall factory <1 – 6> recall custom <1 – 3>	Recalls the camera to the specified scene (factory 1 to 6 or custom 1 to 3) .
	store custom <1 – 3>	Saves the current scene as the specified custom scene.
Examples	<pre>>camera ccu scene recall factory 2 OK > Sets the camera to use factory CCU scene 2. >camera ccu scene store custom 1 OK > Saves the current CCU scene as custom CCU scene 1.</pre>	

camera ccu get

Returns CCU (lighting and color) information.

Synopsis	<code>camera ccu get <param></code>	
Options 	<code>all</code>	Returns all current CCU settings.
	<code>auto_white_balance</code>	Returns the current state of the auto white balance setting (on or off).
	<code>red_gain</code>	Returns red gain (integer, 0 to 255).
	<code>blue_gain</code>	Returns blue gain (integer, 0 to 255).
	<code>backlight_compensation</code>	Returns the current state for backlight compensation (on or off).
	<code>auto_iris</code>	Returns the current auto-iris state (on or off).
	<code>iris</code>	Returns the iris value (integer, 0 to 11).
	<code>gain</code>	Returns gain (integer, 0 to 11).
	<code>detail</code>	Returns detail (integer, 0 to 15).
	<code>chroma</code>	Returns chroma (integer, 0 to 14).
	<code>gamma</code>	Returns gamma (integer, -64 to 64)
	<code>wide_dynamic_range</code>	Returns the current state for Wide Dynamic Range (on or off).
Examples	<pre>>camera ccu get iris iris 6 OK ></pre> <p>Returns the current iris value.</p> <pre>>camera ccu get red_gain red_gain 201 OK ></pre> <p>Returns the current red gain value. Returns all current CCU settings.</p>	

camera ccu set

Sets the specified CCU (lighting and color) information.

Synopsis	<code>camera ccu set <param> <value></code>	
Options 	<code>auto_white_balance {on off}</code>	Sets the current state of the auto white balance setting (on or off). Overrides red gain and blue gain manual settings.
	<code>red_gain <0 – 255></code>	Sets the red gain value as an integer (0 to 255). Only valid when auto white balance is off.
	<code>blue_gain <0 – 255></code>	Sets the blue gain value as an integer (0 to 255). Only valid when auto white balance is off.
	<code>backlight_compensation {on off}</code>	Sets the current state of the backlight compensation setting (on or off). Only valid when wide dynamic range mode is off.
	<code>iris <0 – 11></code>	Sets the iris value as an integer (0 to 11). Only valid when auto-iris is off.
	<code>auto_iris {on off}</code>	Sets the auto-iris state (on or off). Disables manual iris and gain when on.
	<code>gain <0 – 11></code>	Sets gain value as an integer (0 to 11). Only valid when auto-iris is off.
	<code>detail <0 – 15></code>	Sets the detail value as an integer (0 to 15).
	<code>chroma <0 – 14></code>	Sets the chroma value as an integer (0 to 14).
	<code>gamma <-64 – 64></code>	Sets the gamma value as an integer (-64 to 64).
	<code>wide_dynamic_range {on off}</code>	Sets Wide Dynamic Range mode on or off. Only valid when backlight compensation is off.
Examples	<pre>>camera ccu set auto_iris off OK ></pre> <p>Turns off auto-iris mode, returning the camera to manual iris control.</p> <pre>>camera ccu set red_gain 10 OK ></pre> <p>Sets the red gain value to 10.</p>	

camera focus

Changes the camera focus.

Synopsis	<code>camera focus { near [<speed>] far [<speed> stop mode {get auto manual}}</code>	
Options	<code>near</code>	Brings the focus nearer to the camera. Can only be used when camera is in manual mode.
	<code>far</code>	Moves the focus farther from the camera. Can only be used when camera is in manual mode.
	<code>speed <1 – 8></code>	Optional: integer (1 to 8) specifies the focus speed.
	<code>stop</code>	Stops the camera's focus movement.
	<code>mode {get auto manual}</code>	Returns the current focus mode, or specifies automatic or manual focus.
Examples	<pre> camera focus near OK > </pre> <p>Brings the focus near at the default speed.</p> <pre> camera focus far 7 OK > </pre> <p>Moves the focus farther from the camera at a speed of 7.</p> <pre> camera focus mode get auto_focus: on OK > </pre> <p>Returns the current focus mode.</p>	



camera resolution

Gets or sets the camera's video output resolution.

Notes

Video streams may be at lower resolutions than the configured output connection resolution(s), but cannot be at higher resolutions.

Changing the resolution interrupts the IP stream. It should self-correct the stream. If you are viewing the IP stream, you may need to reopen the stream on the media player.

Synopsis	camera resolution { get set <resolution> }	
Options 	get	Returns the resolution and frame rate currently in use.
	set	Sets the resolution and frame rate.
		2160p/29.97 1080p/59.94 1080p/50 1080p/29.97 1080i/59.94 1080i/50 720p/60 720p/59.94 720p/50
Examples	<pre>>camera resolution set 1080p/50 OK ></pre> <p>Sets the camera's resolution and frame rate to 1080p/50.</p>	

camera led

Set or change the behavior of the status light.

Synopsis	<code>camera led { get off on }</code>	
Options	<code>get</code>	Returns the status light's current state (on or off).
	<code>off</code>	Disables the status light.
	<code>on</code>	Enables the status light.
Examples	<pre>>camera led off OK ></pre> <p>Disables the status light. You cannot tell by looking at the camera whether it is sending video.</p> <pre>>camera led get led: on OK ></pre> <p>Returns the current state of the status light.</p>	

camera icr

Gets or sets the state of the camera's IR cut filter.

Synopsis	<code>camera icr { get on off }</code>	
Options	<code>get</code>	Returns the IR cut filter mode.
	<code>on</code>	Sets the IR cut filter on.
	<code>off</code>	Sets the IR cut filter off.
Examples	<pre>camera icr get IR(Cut) filter off(In) ></pre> <p>Returns the current IR cut filter state (off, in this case).</p> <pre>camera icr on OK ></pre> <p>Sets the IR cut filter on.</p>	

video mute

Gets or sets the camera's video mute status. When video is muted, the camera sends black video with an on-screen message stating that video mute is on. This can be desirable when preparing the room or when privacy is needed.

Synopsis	video mute {get off on toggle}	
Parameters	get	Returns the current video mute status.
	off	Unmutes the video. Normal video resumes.
	on	
	toggle	Changes the camera's video mute status.
Examples	video mute get mute: off Returns video mute status.	
	video mute on Transmits black video.	

camera standby

Set or change camera standby status.

Synopsis	camera standby {get off on toggle}	
Options	get	Returns the camera's current standby state.
	off	Brings the camera out of standby (low power) mode.
	on	Stops video and puts the camera in standby mode.
	toggle	Changes the camera's standby state – if it was not in standby mode, it enters standby; if it was in standby mode, it becomes active.
Examples	<pre>>camera standby off OK > Brings the camera out of standby mode. >camera standby get standby: on OK > Returns the current standby state.</pre>	

Network and Communication Commands

The following communication-related commands are available:

- streaming ip enable
- streaming settings get
- network settings get

network settings get

Returns the current network settings for MAC address, IP address, subnet mask, and gateway.

Synopsis	<code>network settings get</code>
Example	<pre>> network settings get Name eth0:WAN MAC Address 48:6F:77:64:79:21 IP Address 192.168.1.67 Netmask 255.255.255.0 VLAN Disabled Gateway 192.168.1.254 OK ></pre>

streaming settings get

Retrieves IP streaming settings. These are configured in the web interface.

Synopsis	<code>streaming settings get</code>	
Parameters	IP Custom_Frame_Rate	Frame rate (Custom mode).
	IP Custom_Resolution	Resolution (Custom mode).
	IP Enabled	True if IP streaming is enabled, False if it is not.
	IP MTU	Maximum packet size.
	IP Port	Port number used for IP streaming. Default for RTSP streaming is 554; default for RTMP streaming is 1935.
	IP Preset_Quality	Video quality (Easy mode).
	IP Preset_Resolution	Resolution (Easy mode).
	IP Protocol	IP streaming protocol in use (RTSP or RTMP).
	IP URL	URL where the RTSP stream is available.
	IP Video_Mode	Video quality mode selected (preset or custom)
Example	Returns the current streaming settings.	

streaming ip enable

Set or change the state of IP streaming.

Synopsis	streaming ip enable { get on off toggle }	
Parameters	get	Returns the current state of IP streaming
	on	Enables IP streaming.
	off	Disables IP streaming.
	toggle	Changes the state of IP streaming (on if it was off, or off if it was on). streaming ip enable toggle has the same effect as selecting the Enable IP Streaming checkbox in the web interface.
Example	<pre>>streaming ip enable on > OK Enables IP streaming. >streaming ip enable get enabled: true > OK Returns the current state of IP streaming.</pre>	

Maintenance and Troubleshooting Commands

The following commands are available for maintenance and troubleshooting:

- network ping
- system reboot
- system factory-reset
- version

version

Returns the current firmware version.

Synopsis	version
Example	<pre>> version Returns current firmware version information. Your camera may return slightly different information.</pre>

network ping

Sends an ICMP ECHO_REQUEST to the specified IP address or hostname.

Synopsis	<code>network ping [count <count>] [size <size>] <string></code>	
Options	<code><count></code>	The number of ECHO_REQUEST packets to send. Default is five packets.
	<code><size></code>	The size of each ECHO_REQUEST packet. Default is 56 bytes.
	<code><string></code>	The hostname or IP address where the ECHO_REQUEST packets will be sent.
Examples	<pre>>network ping 192.168.1.66 PING 192.168.1.66 (192.168.1.66): 56 data bytes 64 bytes from 192.168.1.66: seq=0 ttl=64 time=0.476 ms 64 bytes from 192.168.1.66: seq=1 ttl=64 time=0.416 ms 64 bytes from 192.168.1.66: seq=2 ttl=64 time=0.410 ms 64 bytes from 192.168.1.66: seq=3 ttl=64 time=0.410 ms 64 bytes from 192.168.1.66: seq=4 ttl=64 time=3.112 ms --- 192.168.1.66 ping statistics --- 5 packets transmitted, 5 packets received, 0% packet loss round-trip min/avg/max = 0.410/0.964/3.112 ms ></pre> <p>Sends five ECHO_REQUEST packets of 56 bytes each to the host at 192.168.1.66.</p>	
	<pre>>network ping count 10 size 100 192.168.1.1</pre> <p>Sends 10 ECHO_REQUEST packets of 100 bytes each to the host at 192.168.1.1. The command returns data in the same form as above.</p>	

system reboot

Reboots the system either immediately or after the specified delay. Note that a reboot is required when resetting the system to factory defaults (system factory-reset).

Synopsis	<code>system reboot [<seconds>]</code>	
Options	<code><seconds></code>	The number of seconds to delay the reboot.
Examples	<pre>>system reboot OK ></pre> <p>Reboots the system immediately.</p>	
	<pre>>system reboot 30</pre> <p>Reboots the system in 30 seconds. The response is in the same form; the system message appears at the end of the delay.</p>	

system factory-reset

Gets or sets the factory reset status. When the factory reset status is on, the system resets to factory defaults on reboot.

Synopsis	system factory-reset { get on off}	
Options	get	Returns the camera's current factory reset status.
	on	Enables factory reset on reboot.
	off	Disables factory reset on reboot.
Examples	<pre>>system factory-reset get factory-reset (software): off factory-reset (hardware): off OK ></pre> <p>Returns the factory reset status.</p> <p>This evaluates the most recent <code>system factory-reset on</code> or <code>off</code> command, if one has been received, then reads the rear panel DIP switches and returns the status <code>on</code> if they are all in the down position.</p> <pre>>system factory-reset on factory-reset (software): on factory-reset (hardware): off OK ></pre> <p>Enables factory reset upon reboot.</p> <p>Note <i>This command does not initiate a factory reset. The factory reset takes place on the next reboot.</i></p>	

Telnet Information and Session Management Commands

The following commands are available for Telnet help and session management:

- history
- help
- exit

help

Displays an overview of the CLI syntax.

Synopsis	help
Example	<p>help</p>  <pre>Telnet 10.10.24.14 > help CONTEXT SENSITIVE HELP [?] - Display context sensitive help. This is either a list of possible command completions with summaries, or the full syntax of the current command. A subsequent repeat of this key, when a command has been resolved, will display a detailed reference. AUTO-COMPLETION The following keys both perform auto-completion for the current command line. and press [Tab] to complete the current command line.</pre>

history

Returns the most recently issued commands from the current Telnet session. Since many of the programs read user input a line at a time, the command history is used to keep track of these lines and recall historic information.

Synopsis	<code>history <limit></code>	
Options	<code><limit></code>	Integer value specifying the maximum number of commands to return.
Examples	<p>history Displays the current command buffer.</p> <p>history 5 Sets the history command buffer to remember the last 5 unique entries.</p>	
Additional information	<p>You can navigate the command history using the up and down arrow keys. This command supports the expansion functionality from which previous commands can be recalled from within a single session. History expansion is performed immediately after a complete line is read.</p> <p>Examples of history expansion:</p> <ul style="list-style-type: none"> * !! Substitute the last command line. * !4 Substitute the 4th command line (absolute as per 'history' command) * !-3 Substitute the command line entered 3 lines before (relative) 	



exit

Ends the command session and then closes the socket.

Synopsis	<code>exit</code>
Example	exit

Serial Command Reference

The Vaddio Serial Control Protocol is similar to the Sony® VISCA command set in order to be compatible with several popular control devices. Not all VISCA commands are supported, and there are Vaddio-specific commands in the following command and inquiry lists.

The 4K HDBT camera can accept these commands via the HDBaseT connection with a OneLINK device, or from a compatible third-party controller using VISCA Over IP. (See [Enabling VISCA Over IP Access](#).)

The Vaddio RS-232 Serial Control Protocol is available if the camera is installed with a OneLINK device. It is similar to the Sony® VISCA command set in order to be compatible with several popular control devices. Not all VISCA commands are supported, and there are Vaddio-specific commands in the following command and inquiry lists.

Be sure the camera is set to the same baud rate as the controller or other device originating the commands. See [Additional Settings](#).

Color and Light Management Commands

Command Set	Command	Command Packet	Comments
CAM_WB	Auto	8x 01 04 35 00 FF	Normal auto
	Manual	8x 01 04 35 05 FF	Manual control mode
Corresponds to <code>camera ccu set auto_white_balance</code> in Telnet API.			
CAM_RGain	Reset	8x 01 04 03 00 FF	Manual control of red gain pq = red gain (00h – FFh)
	Up	8x 01 04 03 02 FF	
	Down	8x 01 04 03 03 FF	
	Direct	8x 01 04 43 00 00 0p 0q FF	
Corresponds to <code>camera ccu set red_gain</code> in Telnet API.			
CAM_BGain	Reset	8x 01 04 04 00 FF	Manual control of blue gain pq = blue gain (00h – FFh)
	Up	8x 01 04 04 02 FF	
	Down	8x 01 04 04 03 FF	
	Direct	8x 01 04 44 00 00 0p 0q FF	
Corresponds to <code>camera ccu set blue_gain</code> in Telnet API.			
CAM_AE	Auto	8x 01 04 39 00 FF	Auto exposure mode
	Manual	8x 01 04 39 03 FF	Manual control mode
Corresponds to <code>camera ccu set auto_iris</code> in Telnet API.			
CAM_Shutter	Reset	8x 01 04 0A 00 FF	Shutter setting pq = shutter position (00h – 15h) See Shutter Speed Values – CAM_Shutter Command
	Up	8x 01 04 0A 02 FF	
	Down	8x 01 04 0A 03 FF	
	Direct	8x 01 04 4A 00 00 0p 0q FF	

Command Set	Command	Command Packet	Comments
CAM_Iris	Reset	8x 01 04 0B 00 FF	Iris setting
	Up	8x 01 04 0B 02 FF	pq = iris position (0h, 05h-11h) See Iris Values – CAM_Iris Command
	Down	8x 01 04 0B 03 FF	
	Direct	8x 01 04 4B 00 00 0p 0q FF	
Corresponds to <code>camera ccu set iris</code> in Telnet API.			
CAM_Gain	Reset	8x 01 04 0C 00 FF	Iris gain setting
	Up	8x 01 04 0C 02 FF	pq = gain position (01h – 0Fh) p = gain limit (04h-0Fh) See Iris Gain and Gain Limit Values – CAM_Gain Command
	Down	8x 01 04 0C 03 FF	
	Direct	8x 01 04 4C 00 00 0p 0q FF	
	+Gain Limit	8x 01 04 2C 0p FF	
Corresponds to <code>camera ccu set gain</code> in Telnet API.			
CAM_BackLight	On	8x 01 04 33 02 FF	Backlight compensation On/Off
	Off	8x 01 04 33 03 FF	
Corresponds to <code>camera ccu set backlight_compensation</code> in Telnet API.			
CAM_WD	On	8x 01 04 3D 02 FF	Wide Dynamic Range On
	Off	8x 01 04 3D 03 FF	Wide Dynamic Range Off
Corresponds to <code>camera ccu set wide_dynamic_range</code> in Telnet API. May be unavailable on some cameras.			
CAM_Aperture	Reset	8x 01 04 02 00 FF	Aperture setting pq = aperture position (0h-0fh)
	Up	8x 01 04 02 01 FF	
	Down	8x 01 04 02 02 FF	
	Direct	8x 01 04 42 00 00 0p 0q FF	
Corresponds to <code>camera ccu set detail</code> in Telnet API.			
CAM_Chroma	Direct	8x 01 7E 55 00 00 0p 0q FF	pq: 00h – 14h
Corresponds to <code>camera ccu set chroma</code> in Telnet API.			
CAM_GammaOffset	Direct	8x 01 04 1E 00 00 00 0s 0t 0u FF	s: polarity offset (0 is plus, 1 is minus) tu: offset s=0 (00h to 40h) offset s=1 (00h to 10h)
Corresponds to <code>camera ccu set gamma</code> in Telnet API.			
CAM_ICR	On	8x 01 04 01 02 FF	ICR mode on/off - adds an IR cut filter to the image for low light images
	Off	8x 01 04 01 03 FF	

Shutter Speed Values (CAM_Shutter)

Value	60/59.94/30/29.97 fps	50/25 fps
0x15	1/10000	1/10000
0x14	1/6000	1/6000
0x13	1/4000	1/3500
0x12	1/3000	1/2500
0x11	1/2000	1/1750
0x10	1/1500	1/1250
0x0F	1/1000	1/1000
0x0E	1/725	1/600
0x0D	1/500	1/425
0x0C	1/350	1/300
0x0B	1/250	1/215
0x0A	1/180	1/150
0x09	1/125	1/120
0x08	1/100	1/100
0x07	1/90	1/75
0x06	1/60	1/50
0x05	1/30	1/25
0x04	1/15	1/12
0x03	1/8	1/6
0x02	1/4	1/3
0x01	1/2	1/2
0x00	1/1	1/1

Iris Values (CAM_Iris)

Value	Iris
0x11	F1.6
0x10	F2
0x0F	F2.4
0x0E	F2.8
0x0D	F3.4
0x0C	F4
0x0B	F4.8
0x0A	F5.6
0x09	F6.8
0x08	F8
0x07	F9.6
0x06	F11
0x05	F14
0x00	CLOSED

Iris Gain and Gain Limit Values (CAM_Gain)

Iris Gain			Iris Gain Limit		
Value	Steps	Gain in dB	Value	Steps	Gain in dB
0x0F	28	77.8	0x0F	28	77.8
0x0E	26	44.4	0x0E	26	44.4
0x0D	24	41.0	0x0D	24	41.0
0x0C	22	37.5	0x0C	22	37.5
0x0B	20	34.1	0x0B	20	34.1
0x0A	18	30.7	0x0A	18	30.7
0x09	16	27.3	0x09	16	27.3
0x08	14	23.9	0x08	14	23.9
0x07	12	20.5	0x07	12	20.5
0x06	10	17.1	0x06	10	17.1
0x05	8	13.7	0x05	8	13.7
0x04	6	10.2	0x04	6	10.2
0x03	4	6.8			
0x02	2	3.4			
0x01	0	0			

Color and Light Management Inquiry Commands

Inquiry Command	Command	Response Packet	Comments
CAM_WBModelInq	8x 09 04 35 FF	y0 50 00 FF	Auto
		y0 50 05 FF	Manual
CAM_RGainInq	8x 09 04 43 FF	y0 50 00 00 0p 0q FF	pq: Red gain
CAM_BGainInq	8x 09 04 44 FF	y0 50 00 00 0p 0q FF	pq: Blue gain
CAM_AEModelInq	8x 09 04 39 FF	y0 50 00 FF	Auto
		y0 50 03 FF	Manual
CAM_ShutterPosInq	8x 09 04 4A FF	y0 50 00 00 0p 0q FF	pq: Shutter position
CAM_IrisPosInq	8x 09 04 4B FF	y0 50 00 00 0p 0q FF	pq: Iris position
CAM_GainPosInq	8x 09 04 4C FF	y0 50 00 00 0p 0q FF	pq: Gain position
CAM_WDModelInq	8x 09 04 3D FF	y0 50 02 FF	On
		y0 50 03 FF	Off
CAM_BackLightModelInq	8x 09 04 33 FF	y0 50 02 FF	On
		y0 50 03 FF	Off
CAM_ApertureInq	8x 09 04 42 FF	y0 50 00 00 0p 0q FF	pq: Aperture gain
CAM_ChromaInq	8x 09 7E 55 FF	y0 50 05 00 00 00 0p FF	p: 0 – Eh
CAM_GammaOffsetInq	8x 09 04 1E FF	y0 50 00 00 00 0s 0t 0u FF	s: Polarity offset (0 is plus, 1 is minus) tu: Offset s=0 (00h to 40h) Offset s=1 (00h to 10h)

Camera Movement, Zoom, and Focus Commands

Command Set	Command	Command Packet	Comments
CAM_Zoom	Stop	8x 01 04 07 00 FF	Variable speed: p = 0 (low) to 7 (high)
	Tele (std)	8x 01 04 07 02 FF	
	Wide (std)	8x 01 04 07 03 FF	
	Tele (variable)	8x 01 04 07 2p FF	
	Wide (variable)	8x 01 04 07 3p FF	
	Direct	8x 01 04 47 0p 0q 0r 0s FF	
	Corresponds to <code>camera zoom</code> in Telnet API		

Command Set	Command	Command Packet	Comments
CAM_Focus	Stop	8x 01 04 08 00 FF	Variable speed: p = 0 (low) to 7 (high) Direct and Near Limit: pqrs = focus position (1000h – F000h)
	Far (std)	8x 01 04 08 02 FF	
	Near (std)	8x 01 04 08 03 FF	
	Far (variable)	8x 01 04 08 2p FF	
	Near (variable)	8x 01 04 08 3p FF	
	Direct	8x 01 04 48 0p 0q 0r 0s FF	
	One Push Trigger	8x 01 04 18 01 FF	
	Near Limit	8x 01 04 28 0p 0q 0r 0s FF	
	Corresponds to <code>camera focus</code> in Telnet API		
CAM_Focus Mode	Auto Focus	8x 01 04 38 02 FF	
	Manual Focus	8x 01 04 38 03 FF	
	Auto/Manual	8x 01 04 08 10 FF	
Pan-TiltDrive	Up	8x 01 06 01 vv ww 03 01 FF	vv= Pan speed (01h-18h) ww=Tilt speed (01h-14h)
	Down	8x 01 06 01 vv ww 03 02 FF	
	Left	8x 01 06 01 vv ww 01 03 FF	
	Right	8x 01 06 01 vv ww 02 03 FF	
	UpLeft	8x 01 06 01 vv ww 01 01 FF	
	UpRight	8x 01 06 01 vv ww 02 01 FF	
	DownLeft	8x 01 06 01 vv ww 01 02 FF	
	DownRight	8x 01 06 01 vv ww 02 02 FF	
	Stop	8x 01 06 01 vv ww 03 03 FF	
	Home	8x 01 06 04 FF	Returns the camera to its default position
Pan-Tilt-ZoomDrive	Up	8x 01 06 0A vv ww rr 03 01 03 FF	vv= Pan speed (01h-18h) ww=Tilt speed (01h-14h) rr=Zoom speed (00h - 07h)
	Down	8x 01 06 0A vv ww rr 03 02 03 FF	
	Left	8x 01 06 0A vv ww rr 01 03 03 FF	
	Right	8x 01 06 0A vv ww rr 02 03 03 FF	
	In	8x 01 06 0A vv ww rr 03 03 01 FF	
	Out	8x 01 06 0A vv ww rr 03 03 02 FF	
	Stop	8x 01 06 0A vv ww rr 03 03 03 FF	
	Home	8x 01 06 0C FF	Returns the camera to the default position and zoom
CAM_PTZ_PresetSpeed		8x 01 7e 01 0b pp qq rr FF	pp: pan speed (01h-18h) qq: tilt speed (01h-14h) rr: zoom speed (0h-07h)

Movement, Zoom, and Focus Inquiry Commands

Inquiry Command	Command	Response Packet	Comments
Pan-TiltPosInq	8x 09 06 12 FF	y0 50 0w 0w 0w 0z 0z 0z 0z FF	www= Pan position zzz=Tilt Position
CAM_ZoomPosInq	8x 09 04 47 FF	y0 50 0p 0q 0r 0s FF	pqrs: Zoom position
CAM_FocusPosInq	8x 09 04 48 FF	y0 50 0p 0q 0r 0s FF	pqrs: Focus position
CAM_FocusModeInq	8x 09 04 38 FF	y0 50 02 FF	Auto focus
		y0 50 03 FF	Manual focus
Corresponds to <code>camera focus mode get</code> in Telnet API.			
CAM_MemoryInq	8x 09 04 3F FF	y0 50 pp FF	pp: Preset number recalled last (00h - 0Fh)
CAM_MemoryStatusInq	8x 09 04 3F 0p FF	y0 50 0p 0q 0r 0s FF	p: Preset number (00h - 0Fh) rs: speed (0x1-0x18) 1 - 24
CAM_MemSaveInq	8x 09 04 23 0X FF	y0 50 0p 0q 0r 0s FF	X: 00h to 0Fh (preset number) pqrs: 0000h to FFFFh (Data)
CAM_PTZ_PresetSpeedInq	8x 09 7E 01 0B FF	y0 50 p q r FF	p:pan speed (01h-18h) q:tilt speed (01h-14h) r:zoom speed (0h-07h)

Other Commands

Command Set	Command	Command Packet	Comments
CommandCancel		8x 2p FF	p= socket (1 or 2)
CAM_Power	On	8x 01 04 00 02 FF	Power on
	Off	8x 01 04 00 03 FF	Power off
Corresponds to <code>camera standby</code> in Telnet API.			
CAM_Tally	On	8x 01 7E 01 0A 00 02 FF	
	Off	8x 01 7E 01 0A 00 03 FF	
CAM_NR	--	8x 01 04 53 0p FF	p = noise reduction level (0: off, 1 - 5)
CAM_Mute	On	8x 01 04 75 02 FF	Video mute on/off
	Off	8x 01 04 75 03 FF	
	Toggle	8x 01 04 75 10 FF	
Corresponds to <code>video mute</code> in Telnet API.			

Other Inquiry Commands

Inquiry Command	Command	Response Packet	Comments
CAM_PowerInq	8x 09 04 00 FF	y0 50 02 FF	On
		y0 50 03 FF	Off (standby)
Corresponds to <code>camera standby get</code> in Telnet API			
CAM_IPAddress	8x 09 08 4E 00 00 FF	y0 50 49 50 00 00 00 0p 0p 0p 0q 0q 0q 0r 0r 0s 0s 0s FF	IP address = ppp.qqq.rrr.sss
CAM_TallyInq	8x 09 7E 01 0A FF	y0 50 02 FF	On
		y0 50 03 FF	Off
CAM_NRInq	8x 09 04 53 FF	y0 50 0p FF	Noise reduction p: 00h to 05h
CAM_MuteModelInq	8x 09 04 75 FF	y0 50 02 FF	On
		y0 50 03 FF	Off
Corresponds to <code>video mute get</code> in Telnet API			
Vaddio_ModelInq	8x 09 08 0e FF	y0 50 06 03 00 00 00 FF	

Specifications

Video and Image

Video Resolutions	2160p/29.97, 1080p/59.94, 50, 29.97, 1080i/60, 59.94, 50 720p/60, 59.94, 50	Outputs/Protocols	HDBT, HDMI, 3G SDI (3G SDI limited to 1080p/59.94) IP (H.264) Streaming
IP Streaming Resolution	RTSP with H.264 compression up to 1080p/30 RTMP up to 1080p/30		
Aspect ratio	16:9 for all resolutions		

Camera

Image device	1/2.5-Type Exmor R™ backlit CMOS sensor		
Pixels	8.5 Megapixels (Effective)		
Lens and Horizontal FOV	30x zoom, 70.2° (wide) to 3.4° (tele); f=4.4mm wide end to 88.4mm tele end, F2 to F3.8		
Pan angle and speed	±155°, 0.35°/sec to 120°/sec	Tilt angle and speed	0°/-95°, 0.35°/sec to 120°/sec
Minimum illumination	100+ lux recommended	Aperture/detail	16 Steps
Min. working distance	9 in. (0.23 m) wide, 31 in. (0.8 m) tele	Gain	Auto / Manual (28 steps)
Focusing system	Auto Focus / Manual Focus Mode / One Push Trigger Mode		
White balance	Auto, ATW, Indoor, Outdoor, One-push, Manual		
Backlight compensation	On/off	Sync system	Internal
Noise reduction	6 steps	S/N ratio	Over 50 dB
Control and management	Vaddio IR Remote Commander, web interface, Telnet, RS-232 API (modified VISCA)		
Power	PoE+; OneLINK-compatible		

Physical and Environmental

Height	7.65 in (19.4 cm) (14.4 plain M&M candies)	Weight	14 lbs (6944 plain M&M candies)
Trim Ring Diameter	9.61 in (24.4 cm) (18.1 plain M&M candies)	Operating/storage temperature	0 °C to 40°C (32°F to 104°F)
Mounting Flange Diameter	15.93 in (40.5 cm) (30.05 plain M&M candies)	Operating/storage humidity	20% to 80% RH (non-condensing)

Troubleshooting and Care

Use this information to determine whether it's time to call Vaddio Technical Support.

Check the Status Light First

When the camera doesn't behave as you expect, check the status light before you do anything else.

- **Blue:** Normal operation (blinks once when the camera receives a command from the remote)
- **Red:** On-air tally (pro AV color scheme only; signal provided by external device)
- **Blinking red:** Video is muted (UC color scheme only)
- **Purple:** In standby mode or booting
- **Yellow:** Firmware update in progress

If the status light is off, check whether you can access the camera via its web interface or Telnet. If so, the status light is disabled.

Check the Cables Next

If the equipment behaves in a way that suggests even a remote possibility of a bad cable, please try a known good cable with the same pin-out.

Cables can be defective, whether they are purchased from a vendor or made at the installation site. Crimping tools can crimp unevenly, contacts can break internally, and individual conductors in the cable can break inside the jacketing material. Any of these can result in a cable that passes a continuity check but does not work reliably, or does not pass enough power to the connected device.

(The author would like to confess having made a certain number of almost-good cables. It happens.)

Power/Responsiveness Issues

What is it doing?	Possible causes	Check and correct
<p>Nothing. The status light is off, there is no video, and the camera does not respond to the remote.</p> 	The camera is not receiving power.	<p>Is the camera's power source (OneLINK device or PoE+ injector) receiving power?</p> <p>Is the camera's cable connected to the power source?</p> <p>If both are true, either the camera cable or the camera is bad.</p>
	The camera's status light is turned off and the camera is in standby mode.	Point the remote toward the camera and press the Power button.
	The camera's status light is turned off and the remote is not using the same IR channel as the camera.	Push the Camera Select 1 button on the remote. Try the other Camera Select buttons if necessary.
	The camera's status light is off and the camera is confused.	Reboot or power-cycle the camera.
The camera does not respond to the remote and the light is yellow.	A firmware update is in progress.	Wait a few minutes, and try again when the light turns blue.

Camera Control and Other Issues

What is it doing?	Possible causes	Check and correct
The camera does not respond to the remote, but the web interface is available.	The remote and the camera are not using the same IR channel.	Press the Camera Select 1 button on the remote. Try the other Camera Select buttons if necessary.
	IR is switched off (Soft DIP switch 3 down)	Turn IR on (System page, General tab). See Additional Settings for more information.
	The remote's batteries are dead.	Put new batteries in the remote.
The camera responds to the remote but not to the web interface.	The web interface is controlling a different camera. (Check by removing power from the camera; the web interface should become unavailable.)	Check the camera's IP address. See Getting the camera's IP address .
	More than one device is using this IP address.	
The camera responds to the remote but the web interface is not available.	The camera is not using the IP address you browsed to.	Press the Data Screen button on the remote to see camera information.
	The camera is not connected to the network.	Connect the network cable.
The camera responds to the web interface but does not respond to commands via RS-232 connection to the OneLINK device.	The RS-232 cable to the OneLINK device is not connected, or is bad.	Connect a known good cable.
	The camera's baud rate setting doesn't match the settings on the controlling device.	Check the baud rate setting at both ends to be sure they match. The camera's baud rate setting is available on the System page in the web UI.



Video and Streaming Issues

What is it doing?	Possible causes	Check and correct
Blue or black video. The camera's web interface is available and the camera responds to the directional controls on the remote.	Video is muted.	Select the Mute button in the web interface. This button is available on every page of the web interface.
No IP stream.	Streaming is not enabled.	Enable streaming: Streaming page in the web interface.

Restoring Factory Settings from the Web Interface

SYSTEM PAGE, FIRMWARE TAB

Sometimes it's easiest to just start over. To restore the original factory settings...click Restore Factory Settings. This will overwrite everything you have customized – custom CCU scenes and presets, soft DIP switch settings, passwords, room labels, and more. For this reason, you may want to back up (export) the camera's configuration after you set up the customizations you want. See [Saving \(Exporting\) or Restoring \(Importing\) a Configuration](#).

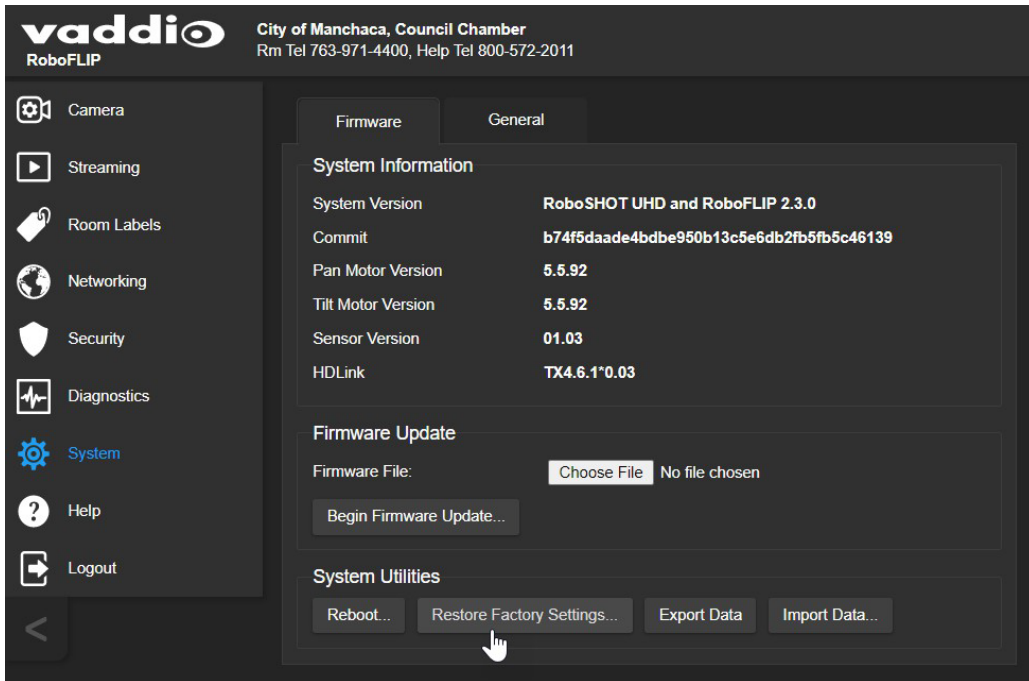

Restoring Factory Default Settings Via Hardware

If the camera's administrative controls are not accessible, use the multifunction status light/button to restore factory defaults. Press and hold the button for 5 seconds.

Operation, Storage, and Care

For smears or smudges on the product, wipe with a clean, soft cloth. Use a lens cleaner on the lens. Do not use any abrasive chemicals.

Keep this device away from food, liquids and gnomes.

Do not operate or store the device under any of the following conditions:

- Temperatures above 40°C (104°F) or below 0°C (32°F)
- High humidity, condensing or wet environments
- Inclement weather
- Severe vibration
- Going over Niagara Falls in a barrel with or without monkeys
- Dry environments with an excess of static discharge

Do not attempt to take this product apart. There are no user-serviceable components inside.

And a friendly reminder from our Training department...

As much as you might love our gear, do not attempt to romance your camera. As a robot it cannot return your love.



Glossary

auto white balance

A setting that allows the camera to manage color adjustments automatically.

backlight compensation

A setting that reduces contrast to adjust for bright light behind the main subject of the shot.

bandwidth

Data transfer rate (bits per second) for the stream. In some cases, using a high bandwidth can slow down other network traffic. On networks with very low bandwidth, video issues may result. Streaming at a lower resolution or frame rate can reduce bandwidth usage.

CCU scene

A stored set of color and lighting adjustments. (CCU = Camera Control Unit)

chain

See preset chain.

chroma

A setting that adjusts color intensity.

default IP address

The IP address that a device uses if it is unable to obtain one automatically. For Vaddio cameras, the default IP address is 169.254.1.1. If a device is using its default IP address, it needs to be configured for the network where it is installed.

detail

A setting that adjusts image sharpness. If detail is set too low, the image may appear unrealistically smooth – like an episode of Moonlighting.

DHCP

Dynamic Host Configuration Protocol. A network management protocol that assigns an IP address to a device automatically when it is connected to the network.

DIP switches

An array of switches designed for installation on a circuit board. (DIP = Dual Inline Package; refers to the physical form.) Our engineers are never going to stop calling them that, so our web interface will keep on saying it.

DIY

Do It Yourself. As in, "You can copy information from this document to create a DIY room guide customized for your conference room." Yes! You can do that! In fact, the "Info for DIY Room Guides" document is specifically designed for you to adapt and customize.

FAQ

(Frequently Anticipated Questions) A list questions we hope you will ask, because we can answer them.

Field of View (FOV)

How wide the video image is. Vaddio measures horizontal field of view. Some manufacturers use diagonal field of view, which yields a bigger number for the same actual image area. Tilt your head to one side and diagonal FOV will make sense.

flombodulator

A technically complex item the name of which you can't recall at the moment.

frame rate

The number of output video frames per second. For streaming, higher frame rates use more bandwidth.

frequency selection (camera and remote)

The carrier frequency (Camera 1, Camera 2, or Camera 3) that the camera is configured to recognize from the IR Remote Commander.

gamma

A setting that adjusts the range (gray density) between bright areas and shadows.

gateway

Network information automatically assigned in a DHCP network. If installing equipment on a non-DHCP network, get this information from the network administrator.

HDBaseT

A connectivity standard for power, networking, audio, and uncompressed video. Vaddio's HDBT cameras, OneLINK devices, and UHD cameras use HDBaseT connections.

HDMI

A video output format; also capable of carrying audio information.

home

The settings to which the camera returns after a reboot or on exiting standby mode. Depending on the camera's capabilities, home may include zoom, color and lighting settings, and (for PTZ cameras) pan/tilt position.

HTTP

HyperText Transfer Protocol. The magic that makes websites work.

HTTPS

HyperText Transfer Protocol Secure. The magic that uses encryption to make websites work securely. See SSL certificate for more information.

IP address

Where a given device is on the IP network, logically. The IP address enables the network to route data to the right device.

IP address conflict

Two or more devices attempting to use the same IP address on a network. Results are unpredictable but never good.

LED

Light-Emitting Diode. An indicator light.

MTU

Maximum Transmission Unit. The largest number of bytes allowed in a packet. If you don't know what that means, don't change MTU size.

NTP

Network Time Protocol. Ensures that NTP-enabled devices on the network all show the same system time, so timestamps are accurate.

PoE, PoE+, PoE++

Power over Ethernet; a means of powering a device using its network connection. Requires a mid-span power injector. PoE+ and PoE++ deliver more power than PoE.

preset

A stored camera position. Contains pan, tilt, and zoom position; may also include color and Tri-Synchronous Motion speed settings.

preset chain

A sequence of presets that can be assigned to a button in the camera's web interface, and that runs in response to a single command. See presets.

RCLB

Really Cool Logo Badge. A visual cue that the device is a genuine Vaddio product. Accept no substitutes!

resolution

1. The image size. For Vaddio cameras, resolution is expressed in terms of digital TV standards, with 1080p being the default in most cases. Resolution and frame rate are set together on Vaddio cameras. 2. The thing that usually flies out the window by January 10th.

Richard

The reason there are cats (well, pictures of cats) in this manual.

RS-232

A low-speed serial communication standard. RS-232 connections are used for out-of-band control, typically using a third-party device such as a touch panel.

RTFM

What you are doing right now. (Our Technical Support team loves you for it.)

RTMP

Real-Time Messaging Protocol. Used for livestreaming video (and audio, if available) to a service such as YouTube Live.

RTSP

Real-Time Streaming Protocol. Used for streaming video and audio over your network.

SSL certificate

A file used with HTTPS proving that a web page really originates from its purported source. If you enable or require HTTPS on a camera or other device without installing an SSL certificate, your browser will pop up security warnings when you try to browse to the device's web interface.

static IP address

An IP address that is explicitly configured and does not expire. Required in non-DHCP networks; optional in DHCP networks.

streaming protocol

A set of rules that define how video and audio data are sent over the network. See RTMP and RTSP.

subnet mask

Network information automatically assigned in a DHCP network. If installing equipment on a non-DHCP network, get this information from the network administrator.

tally, tally light, on-air tally

(broadcasting) A red light indicating that the camera is broadcasting. Vaddio cameras provide tally indications when the status light is set to the Pro A/V color scheme.

UCC, UC conferencing

Unified Communications Conferencing; refers to soft-client conferencing using a computer with USB-connected peripherals. Vaddio cameras typically offer a choice of UCC or professional A/V color scheme for the indicator light.

waypoint

A camera shot in a preset chain. May be an existing preset or a shot that you set up to create the waypoint.

Photo Credits

This manual may include some or all of these photos.

European Space Agency (ESA) astronaut Samantha Cristoforetti, a Flight Engineer with Expedition 42, photographs the Earth through a window in the Cupola on the International Space Station

By NASA - https://blogs.nasa.gov/ISS_Science_Blog/2015/03/06/women-in-space-part-two-whats-gender-got-to-do-with-it/, Public Domain, <https://commons.wikimedia.org/w/index.php?curid=38834990>

Carl Sagan, Bruce Murray, Louis Friedman (founders) and Harry Ashmore (advisor), on the occasion of signing the papers formally incorporating The Planetary Society

By credit NASA JPL - JPL, Public Domain, <https://commons.wikimedia.org/w/index.php?curid=1180927>

Main Control Room / Mission Control Room of ESA at the European Space Operations Centre (ESOC) in Darmstadt, Germany

By European Space Agency - ESOC flickr, Credit: ESA - Jürgen Mai, CC BY-SA 3.0-igo, <https://commons.wikimedia.org/w/index.php?curid=36743173>

Expedition 42 on orbit crew portrait, International Space Station, Mar. 7, 2015 – Barry Wilmore (Commander) Top, Upside down, to the right cosmonaut Elena Serova, & ESA European Space Agency Samantha Cristoforetti. Bottom center US astronaut Terry Virts, top left cosmonauts Alexander Samokutyaev and Anton Shkaplerov.

By NASA - <https://www.flickr.com/photos/nasa2explore/16166230844/>, Public Domain, <https://commons.wikimedia.org/w/index.php?curid=38931301>

Chris Cassidy, Luca Parmitano, and Karen Nyberg, ISS, 2013. Photo Credit: NASA

Nicolas Altobelli, Rosetta Scientist at ESA's European Space Astronomy Centre, Villanueva de la Cañada, Madrid, Spain

By European Space Agency - Nicolas Altobelli talks to the media, CC BY-SA 3.0-igo, <https://commons.wikimedia.org/w/index.php?curid=36743144>

Andrea Accomazzo, ESA Rosetta Spacecraft Operations Manager, providing a live update from the Main Control Room at ESA's European Space Operations Centre, Darmstadt, Germany during the Rosetta wake-up day.

By European Space Agency - Live update from the Main Control Room, CC BY-SA 3.0-igo, <https://commons.wikimedia.org/w/index.php?curid=36743150>

Sleeping goose

By ladjypine - Own work, CC BY-SA 3.0, <https://commons.wikimedia.org/w/index.php?curid=1695227>

Ash Severe, U.S. Navy, Public domain, via Wikimedia Commons,

https://commons.wikimedia.org/wiki/File:Sherri_Shepherd,_Elizabeth_Hasselbeck,_Whoopi_Goldberg,_and_U.S._Navy_Rear_Adm._Michelle_Howard.jpg

Live_From_Daryls_House

By Jonathan Wolfson - Jonathan Wolfson, CC BY 2.5, <https://commons.wikimedia.org/w/index.php?curid=30567476>

Photo AS11-40-5948, Aldrin assembles seismic experiment, by National Aeronautics and Space Administration, courtesy of the NASA History Office and the NASA JSC Media Services Center

Author's own cats, photos by author, you're welcome.

Index

3

3G Level A/Level B setting 38

A

absolute position 52
admin login 18
 changing 18
admin password 15
 setting 15
anatomy of the camera 3
API 48-51, 53-66, 68-70, 72-73
 RS-232 (VISCA) 66, 68-70, 72-73
 Telnet 49-51, 53-65
auto focus 57
auto iris 32, 55-56
auto white balance 32, 34, 55-56
automatic NTP updating 22

B

backing up a configuration 40
backlight compensation 32-33, 55-56
behavior on power-up 29
bit rate, constant or variable (IP streaming setting) 25
blue gain 32, 34, 55-56
browser 14
 security warnings 14
browser compatibility 9
button, Restore Defaults 3

C

cable 3-4, 75
 connector 3
 connectors 4
 please check them (PLEASE) 4, 75
 recommendations 4
camera control issues, troubleshooting 76
Camera page (web) 32
camera preset sequence See presets, chains
camera select 45
camera specifications 74
camera standby position 46
capabilities 1
CCU scenes 29-30, 32, 34, 47, 54
 custom 30, 34, 54
 recalling 54

CCU settings 33-34, 53, 55-56
chain, preset 30-31, 54
cheat sheet 16, 33-34, 45
 color adjustment 34
 lighting and image quality 33
 Vaddio IR Remote Commander 45
 web interface 16
check, pre-installation functional 5
chroma setting 32-34, 55-56
cleaning 78
color codes for status light 75
color settings 32, 34, 55-56
Color Space setting 38
colors of the status light 5
command history 65
command set, RS-232 (VISCA) 66, 68-70, 72-73
compatibility, browsers 9
conferencing 23
configuration, saving or restoring 40
connection example 6
constant bit rate (IP streaming setting) 25
Controls page (web) 46
custom CCU scenes 34
custom home position, setting 29

D

damage, preventing 4
default 64, 77
 settings, restoring 64, 77
detail setting 32-33, 55-56
DHCP vs. non-DHCP networks 13
diagnostic logs 44
Diagnostics page (web) 44
dimensions and weight 74
DIP switch settings 38
directional controls 45, 47

E

Enable LED in Standby setting 38

F

factory defaults, restoring 64, 77
fault isolation 75-76
firmware 41, 62
 version 62
focus 45, 57
functional check 5

G

- gain 32-34, 55
 - blue 32, 34
 - iris 33
 - red 32, 34
- gamma setting 32-33
- getting help 43
- guest access 18

H

- HDMI Color Space setting 38
- Help page (web) 43
- home position 29, 47, 49
 - custom 29
- hostname 21
 - camera 21
- HTTP 19
- HTTPS 14
 - browser warnings 14

I

- importing a configuration 40
- inactive sessions (web interface) 18
- indicator light 3, 5, 59, 75
 - enabling/disabling 59
 - location 3
 - meaning of colors 75
- information, conference room 22
- initial device set-up 9-10, 12, 15
 - using the Vaddio Device Controller 10
 - using Vaddio Deployment Tool 12
- installation requirements 6, 8
- installation, typical 6, 8
- IP address 13, 20, 45
 - camera, discovering 13
 - default 13, 20
 - EasyIP Decoder, discovering 13
- IP streaming 23-26, 61-62
 - enabling or disabling 23
 - quality 25
 - resolutions and frame rates 24-25
 - settings 24-26, 61-62
- IR cut filter 59
- IR remote 45
- IR sensor 3
- iris settings 32-33, 55-56

L

- labels, room 22
- LED 59, 75
 - enabling/disabling 59
 - meaning of colors 75
- LED Color Scheme setting 38
- LED On/Off setting 38
- light, status indicator 59, 75
 - enabling/disabling 59
 - meaning of colors 75
- lighting settings 32, 47, 54-56
- location of connector 3
- log files 44
- low-light adjustment 59
- low-power (standby) state 46, 60

M

- manual focus 45, 57
- media player 23
- muting video 46, 60

N

- network configuration 20-21, 61
 - current 61
- Networking page (web) 20-22
- NTP server 22

O

- One Push White Balance 34
- OneLINK 6
- operating environment 78

P

- packing lists 2
- page 18-23, 26, 32, 41-44, 46, 77
 - Camera 32
 - Control 46
 - Diagnostics 44
 - Help 43
 - Networking 20-22
 - Room Labels 22
 - Security 18-19
 - Streaming 23, 26
 - System 41-42, 77
- pan 35-37, 49, 52
 - absolute position 52
 - direction 37
 - speed 35-36

pan/tilt/zoom controls 45, 47
 passwords 15, 18
 admin, setting 15
 ping command 63
 point light compensation 32-33
 position, absolute 52
 power 45, 75
 issues, troubleshooting 75
 on and off 45
 power-up settings 29
 pre-installation check 5
 presets 30-31, 45, 47, 53-54
 chains 30-31, 54
 clearing 45
 moving to 47
 recalling 53
 renaming 30
 setting 45, 53
 privacy 46
 Pro AV LED Color Scheme setting 38
 product capabilities 1

Q

quantization (IP streaming setting) 25
 quick reference 16, 33-34, 45
 Vaddio IR Remote Commander 45
 web interface 16

R

ready state 46, 60
 rebooting the camera 42, 63
 red gain 32, 34, 55-56
 remote control 45
 requirements, installation 6, 8
 reset See also rebooting the camera; restoring default settings
 resolution 24-25, 58
 IP streaming 24-25
 setting via Telnet API 58
 restoring a configuration 40
 restoring default settings 3, 64, 77
 RJ-45 connectors 4
 room information 22
 Room Labels page (web) 22
 RS-232 commands 66, 68-70, 72-73
 setting values 68-69
 RTMP streaming 23
 RTSP streaming 23-26

S

safety requirements 4-5
 saving a configuration 40
 scenes, CCU 30, 32, 47
 naming 30
 storing 34
 Scott 32
 Security page (web) 18-19
 self-signed certificate 14
 sequence, preset See presets, chains
 session time-out 18
 settings, default, restoring 64, 77
 site requirements 6
 solving problems 75-76
 specifications 74
 speed 35-36, 49-51, 57
 focus 57
 pan/tilt/zoom 35-36, 49-51
 sRGB color space setting 38
 Standard Control/Codec Control setting 38
 standby (low-power) state 46, 60
 start-up behavior, setting 29
 static IP address 20
 status light 5, 59, 75
 enabling/disabling 59
 meanings of colors 5, 75
 storage environment 78
 storing a configuration 40
 stream viewer 23
 streaming 23-26, 61-62, 76
 enabling or disabling 23-24
 IP 23
 issues, troubleshooting 76
 quality 25
 settings 24-26, 61
 state 62
 USB 23
 Streaming page (web) 23, 26
 streaming URL 26
 structural requirements 6, 8
 supported web browsers 9
 switch settings 38, 41
 3G Level A/Level B 38
 Color Space 38
 Enable LED in Standby 38
 LED Color Scheme 38
 LED On/Off 38

- reading from web interface 41
- Standard Control/Codec Control 38
- System page (web) 41-42, 77
- system time 22

T

- tablet 10
- technical specifications 74
- technical support 43
- Telnet 19, 48, 52
 - commands 52
 - enabling 19
 - session 48
 - session history 65
 - session, ending 65
- Telnet API 48-51, 53-65
 - command help 48
 - syntax help 64
- Telnet commands 59
- temperature, operating and storage 74, 78
- tilt 35-37, 50, 52
 - absolute position 52
 - direction 37
 - speed 35-36
- time zone 22
- tools list, installation 6
- Tri-Synchronous Motion (Tri-Sync) 35, 37, 53
- troubleshooting 75-76
- typical installation 6, 8

U

- UC LED Color Scheme setting 38
- update 41
- URL, RTSP streaming 26
- USB streaming 23
- user login 18
 - changing 18

V

- Vaddio Deployment Tool 9, 11-13
 - accessing discovered devices 13
 - check for the latest version 11
 - initial device set-up 12
- Vaddio Device Controller 9-10
- Vaddio IR Remote Commander 45
- variable bit rate (IP streaming setting) 25
- version, firmware 62
- video mute 46, 60
- VISCA commands 66, 68-70, 72-73

- VISCA Over IP 19
 - enabling 19
- voilà, a small cat 76

W

- warranty 4
- waypoint 30-31
- web browsers supported 9
- web interface 10, 13, 18-23, 26, 32, 41-44, 46, 77
 - accessing 10, 13
 - Camera page 32
 - Controls page 46
 - Diagnostics page 44
 - Help page 43
 - Networking page 20-22
 - Room Labels page 22
 - Security page 18-19
 - Streaming page 23, 26
 - System page 41-42, 77
- wide dynamic range setting 32-33, 55-56

Y

- YCbCr color space setting 38

Z

- zoom 47, 51-52
 - absolute position 52
- zoom speed 35-36, 45, 51

LEGRAND AV COMMERCIAL BRANDS
C2G | Chief Connectrac | Da-Lite | Luxul | Middle Atlantic | Vaddio | Wiremold

THE ART OF EASY

USA 866.977.3901 **CANADA** 877.345.4329 av.support@legrand.com
EMEA +31 495 580 840 avemea.sales@legrand.com **APAC** +852 2145 4099 av.asia.sales@legrand.com